

SOT-23 Encapsulate Adjustable Reference Source

TL431D

General Description

The TL431D is a low voltage three terminal adjustable shunt regulator. The output voltage can be set to any value between 2.495V (VREF) to 36V with two external resistors (please refer application circuit). The high precise Reference voltage tolerance is available in two grades: $\pm 0.5\%$ and $\pm 1.0\%$. This device has a typical minimum cathode current of 40uA. Active output circuitry provides a very sharp turn on characteristic, making this device excellent replacement for Zener diodes in many applications.

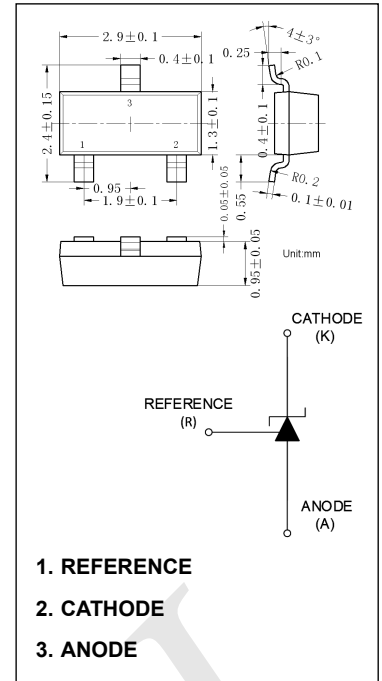

Features

- Precision reference voltage :
 - TL431D : 2.495V $\pm 0.4\%$
- Adjustable output voltage is VREF to 36V
- Sink current capability from 80 μ A to 100mA
- Low Minimum Cathode Current for Regulation: 40 μ A (Typ.), 80 μ A (Max.)

Applications

- Switching Mode Power Supply
- Voltage Reference Application

Symbol	Characteristics	Rating	Unit
V _{KA}	Cathode Voltage	40	V
I _{KA}	Continuous Cathode Current	-100 to 120	mA
I _{REF}	Reference Input Current	10	mA
T _J	Junction Temperature	150	°C
T _{STG}	Storage Temperature	-40~150	°C
θ_{jc}	Thermal Resistance (Junction to Case)	110	°C/W
θ_{ja}	Thermal Resistance (Junction to Ambient)	350	°C/W
P _D	Power dissipation	285	mW
MSL	Moisture Sensitivity	Please refer the MSL label on the IC package bag/carton for detail	

Note1: Ratings apply to ambient temperature at 25°C

Recommended Operating Conditions

Symbol	Characteristics	Min	Max	Unit
V_{KA}	Cathode Voltage	V_{REF}	36	V
I_{KA}	Cathode Current	0.1	100	mA
T_{OP}	Operating Temperature (Operating free-air temperature)	-40	125	°C

Block Diagram

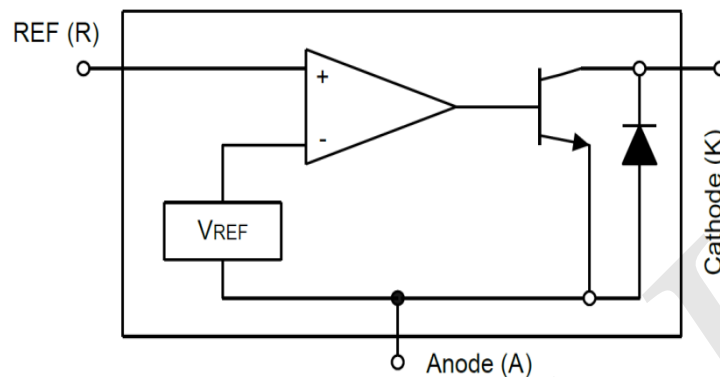

Electrical Characteristics ($T_A=25^\circ\text{C}$, unless otherwise specified)

Symbol	Characteristics	Conditions	Min	Typ	Max	Unit	
V_{REF}	Reference Voltage	$V_{KA} = V_{REF}, I_{KA} = 1\text{mA}$	2.485	2.495	2.505	V	
$V_{REF(DEV)}$	Deviation of Reference Input Voltage over full temperature Range (*Note 2)	$V_{KA} = V_{REF}, I_{KA} = 1\text{mA}$ $T_A = -40\sim 125^\circ\text{C}$	-	10	-	mV	
I_{REF}	Reference Input Current	$R1 = 10\text{K}\Omega, R2 = \infty, I_{KA} = 1\text{mA}$	-	0.035	0.5	μA	
$I_{REF(DEV)}$	Deviation of Reference Input Current over Temperature (*Note 2)	$R1 = 10\text{K}\Omega, R2 = \infty, I_{KA} = 1\text{mA}$ $T_A = -40\sim 125^\circ\text{C}$	-	0.03	0.3	μA	
$\frac{\Delta V_{REF}}{\Delta V_{KA}}$	Ratio of the Change in Reference Voltage to the Change in Cathode Voltage	$I_{KA} = 1\text{mA}$	$\Delta V_{KA} = 10\text{V} \sim V_{REF}$	-	-1.0	-2.7	mV/V
			$\Delta V_{KA} = 36\text{V} \sim 10\text{V}$	-	-0.5	-2.0	
$I_{KA(min)}$	Minimum Cathode Current for Regulation	$V_{KA} = V_{REF}$	-	40	80	μA	
$I_{KA(OFF)}$	Off-state Cathode Current	$V_{KA} = 36\text{V}, V_{REF} = 0\text{V}$	-	0.05	1.0	μA	
Z_{KA}	Dynamic Output Impedance	$V_{KA} = V_{REF}, I_{KA} = 1 \text{ to } 100\text{mA}$, Frequency $\leq 1.0\text{KHz}$	-	0.5	-	Ω	

Note 2 : These specifications are guaranteed by design and are not tested when in mass-production.

Application Circuit

Fig1: $V_{KA}=V_{REF}$

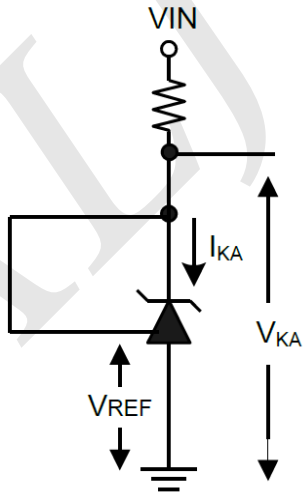

Fig2: $V_{KA}>V_{REF}$

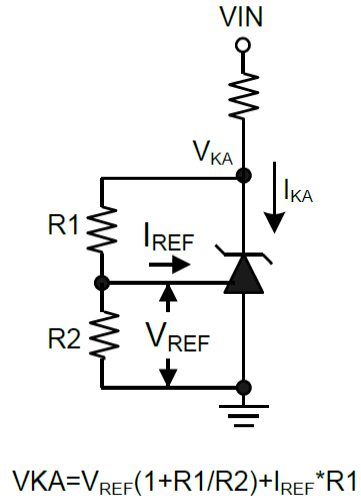
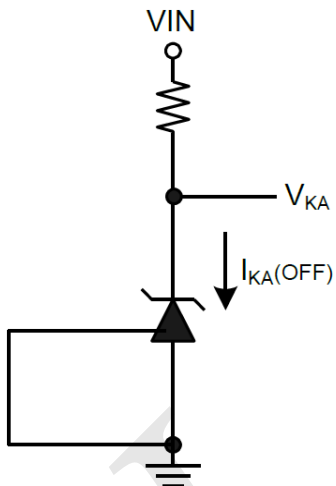
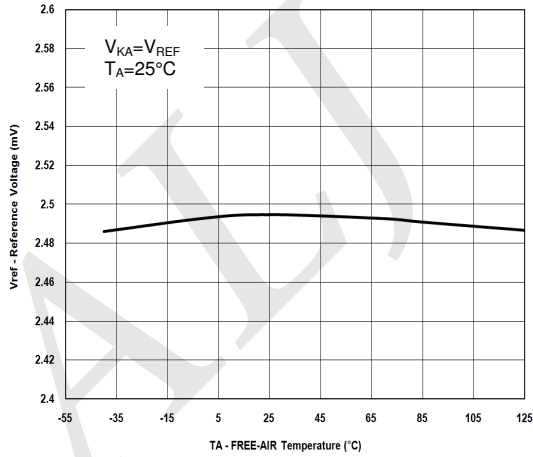

Fig3: Off state current



Typical Characteristics

REFERENCE VOLTAGE VS. FREE-AIR TEMPERATURE



REFERENCE CURRENT VS. FREE-AIR TEMPERATURE

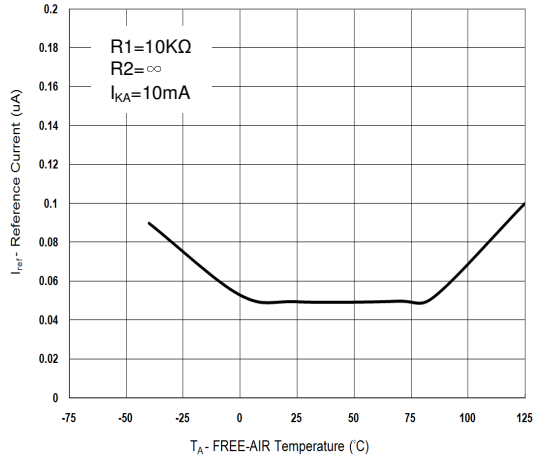

CATHODE CURRENT VS. CATHODE VOLTAGE

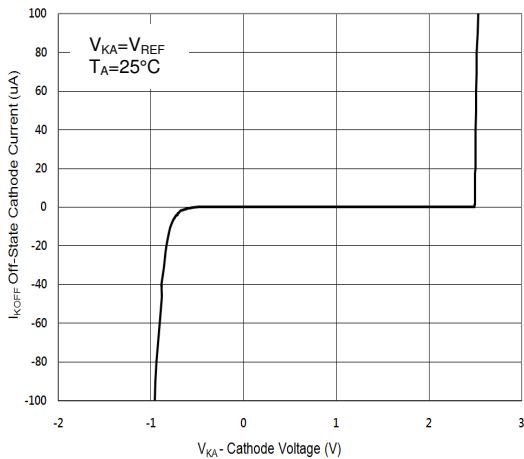

CATHODE CURRENT VS. CATHODE VOLTAGE

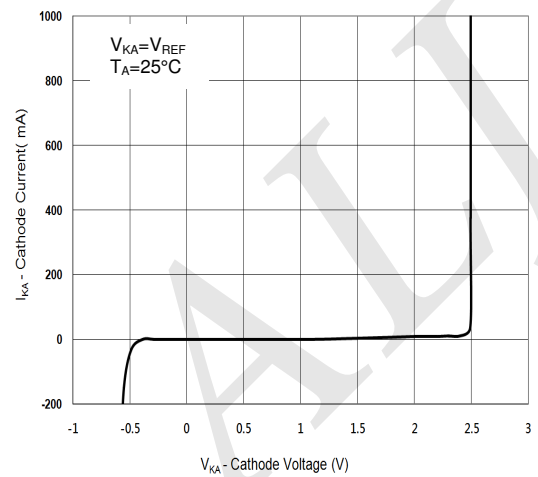

OFF-STATE CATHODE CURRENT VS. FREE-AIR TEMPERATURE

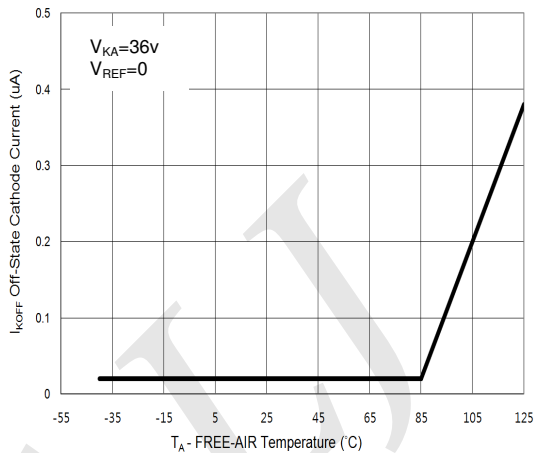

RATIO OF DELTA REFERENCE VOLTAGE TO DELTA CATHODE VOLTAGE VS. FREE-AIR TEMPERATURE

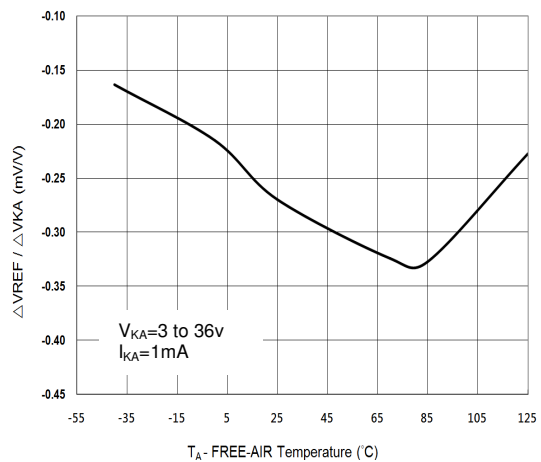

Typical Characteristics(Continued)

(1) Small Signal Voltage Amplification Vs Frequency

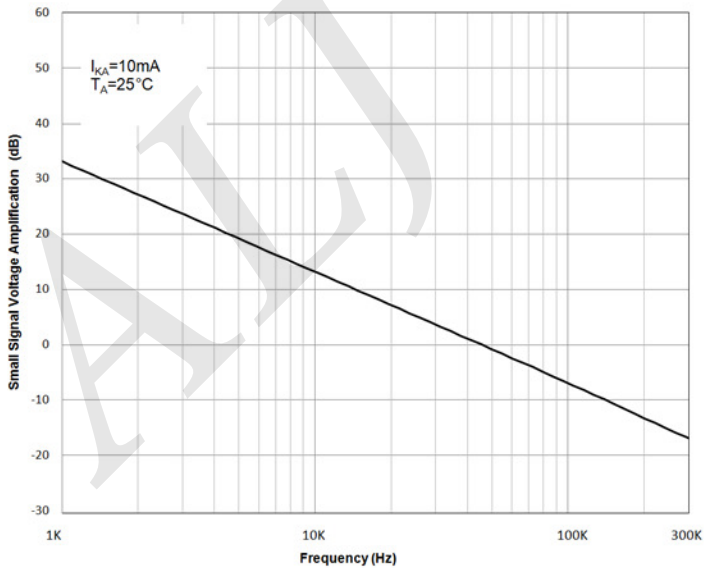

(2) Reference Impedance VS Frequency

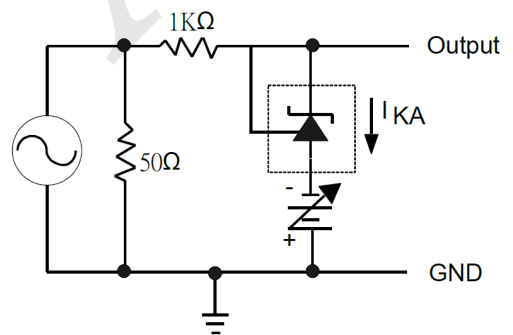
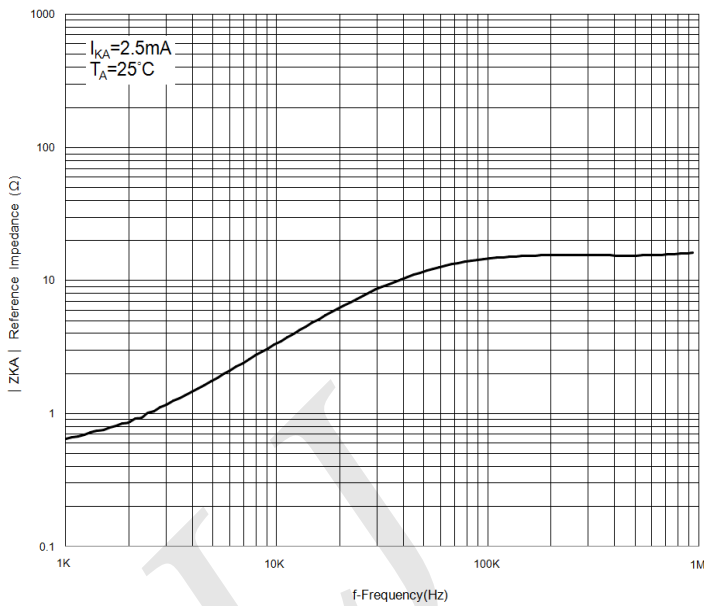

Test Circuit For Reference Impedance

Typical Characteristics (Continued)

(3) Pulse Response

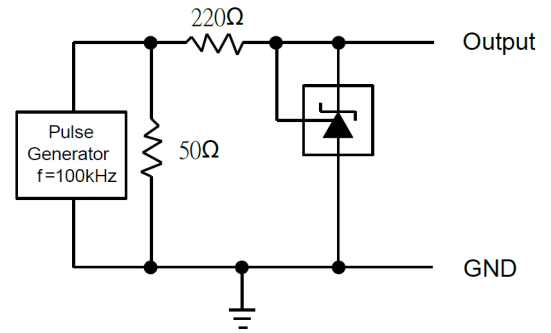
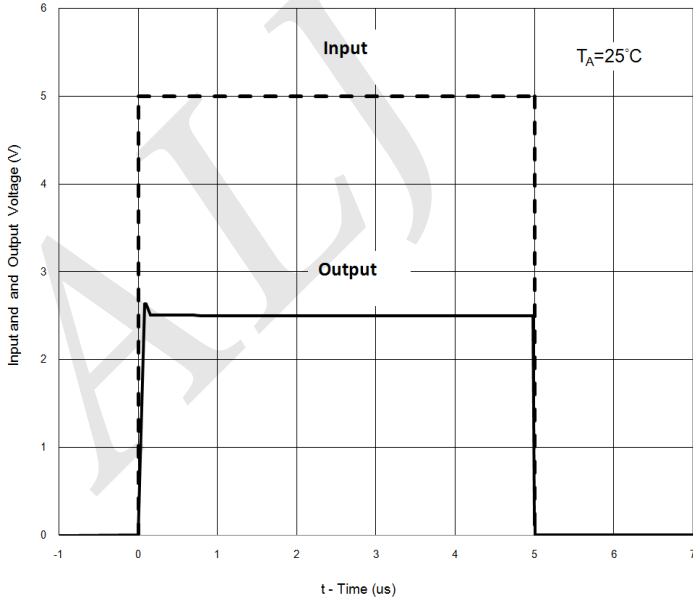

Test Circuit For Pulse Response

(4) Stability boundary conditions

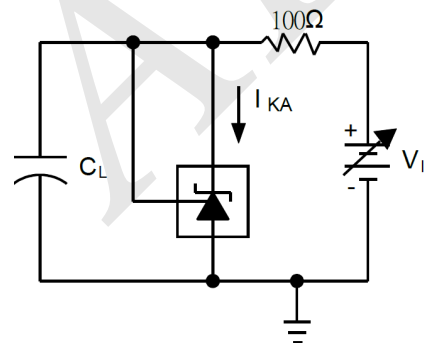
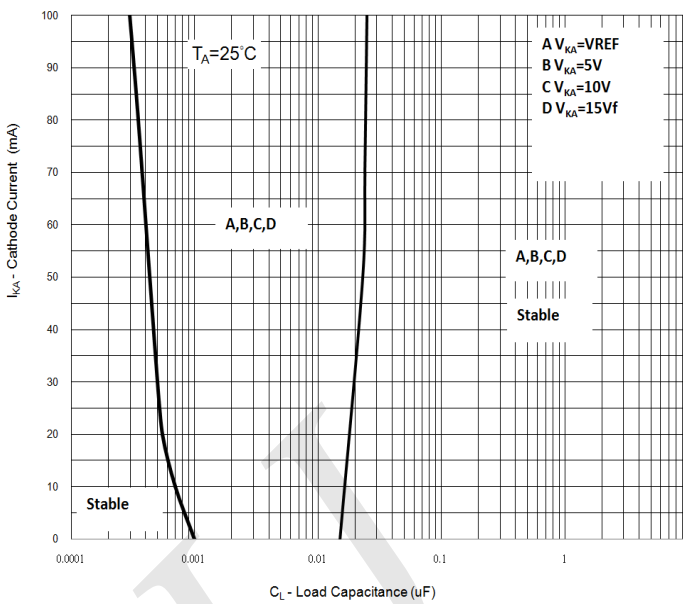

Test Circuit For Curve A

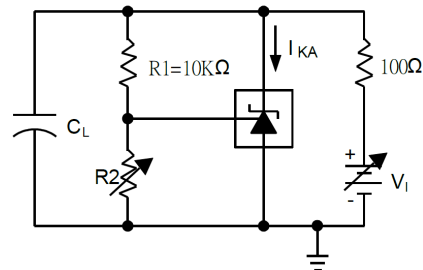

Test Circuit For Curve B

Outline Dimension

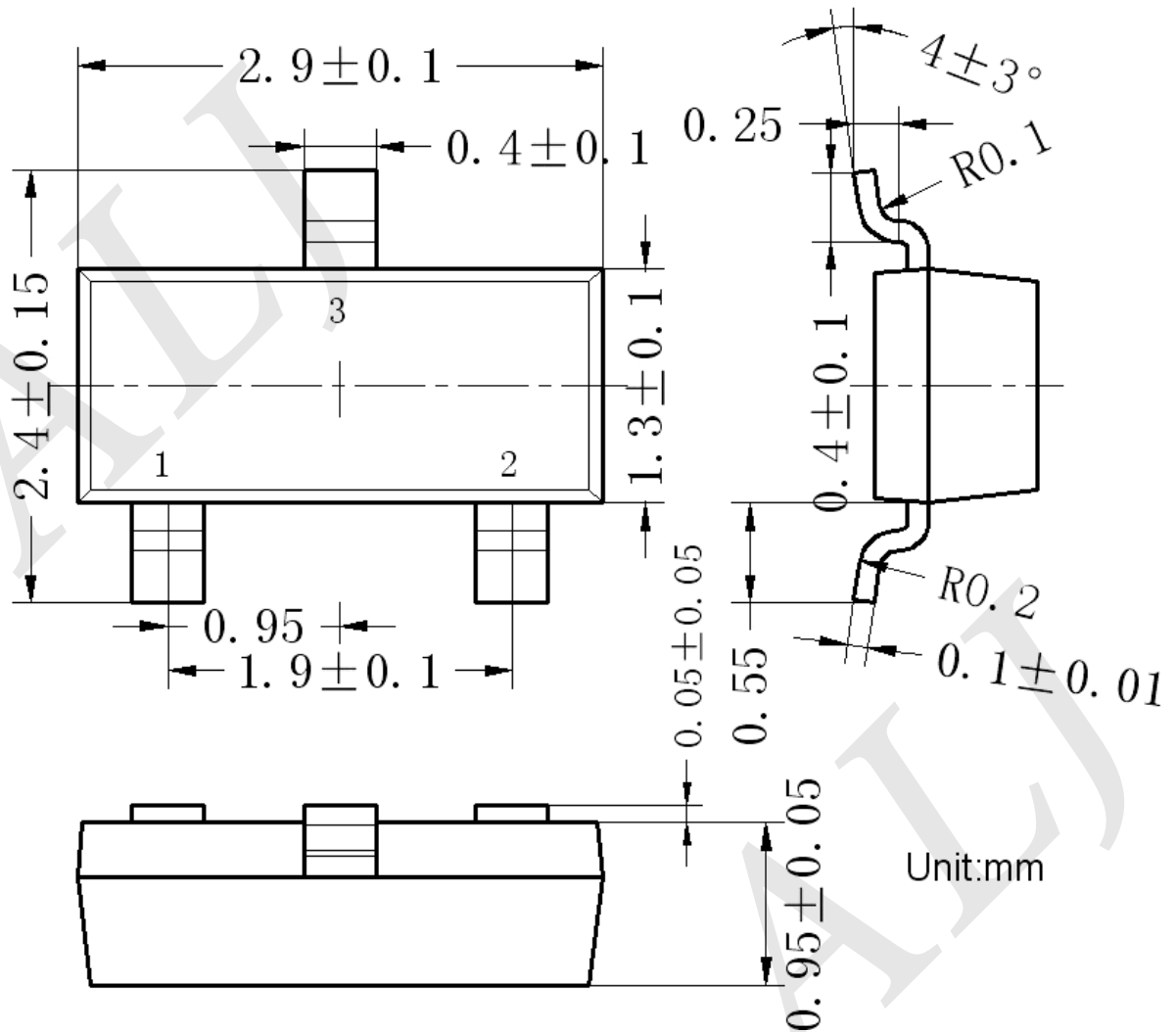

Recommend PCB solder land [Unit: mm]

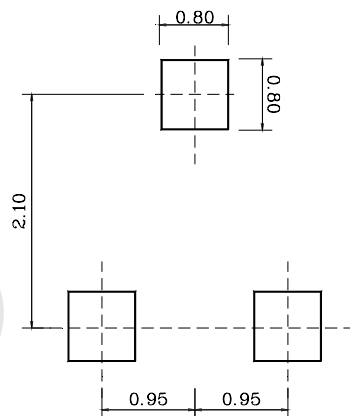

SOT-23 Tape and Reel

SOT-23 Embossed Carrier Tape

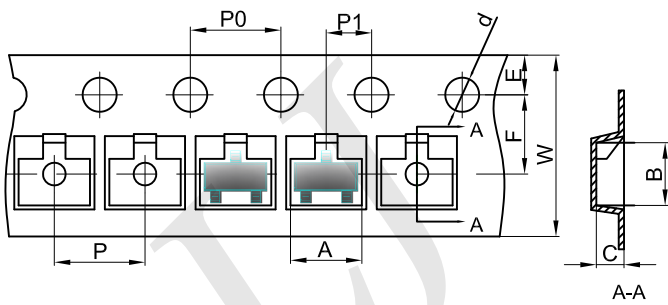

Packaging Description:

SOT-23 parts are shipped in tape. The carrier tape is made from a dissipative (carbon filled) polycarbonate resin. The cover tape is a multilayer film (Heat Activated Adhesive in nature) primarily composed of polyester film, adhesive layer, sealant, and anti-static sprayed agent. These reeled parts in standard option are shipped with 3,000 units per 7" or 17.8cm diameter reel. The reels are clear in color and is made of polystyrene plastic (anti-static coated).

Dimensions are in millimeter

Pkg type	A	B	C	d	E	F	P0	P	P1	W
SOT-23	3.15	2.77	1.22	Ø1.50	1.75	3.50	4.00	4.00	2.00	8.00

SOT-23 Tape Leader and Trailer

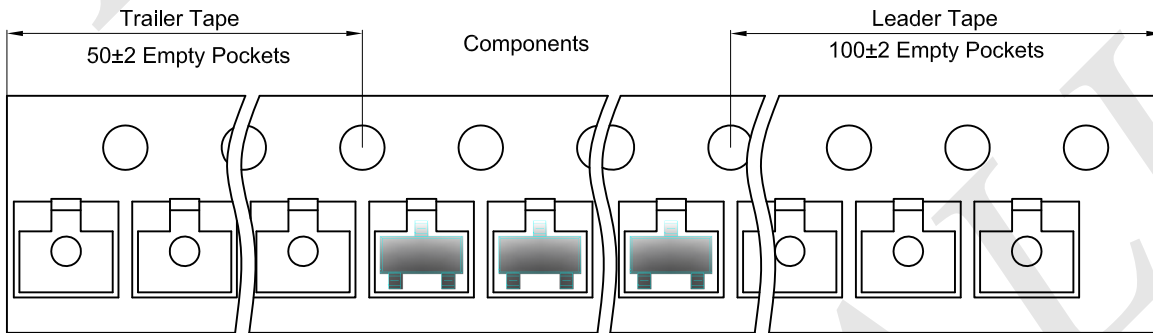

SOT-23 Reel

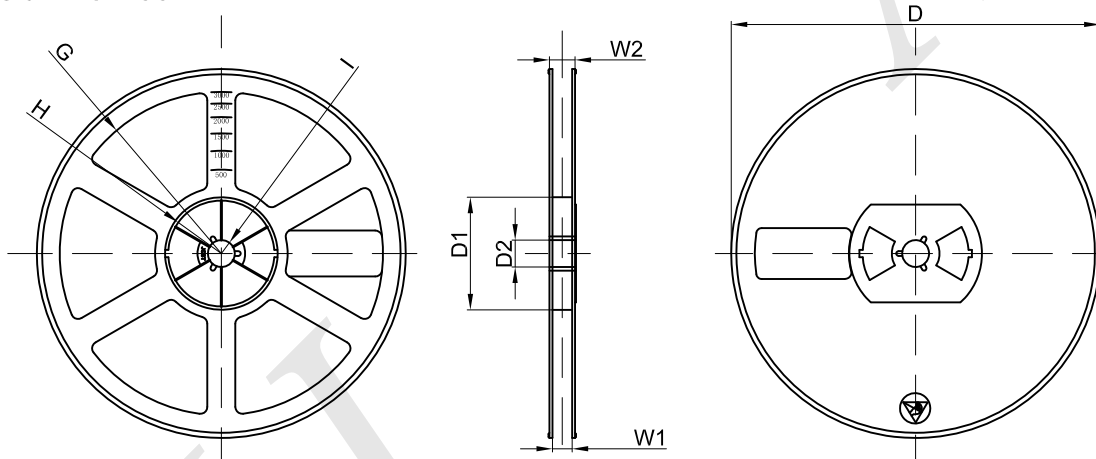

Dimensions are in millimeter

Reel Option	D	D1	D2	G	H	I	W1	W2
7" Dia	Ø178.00	54.40	13.00	R78.00	R25.60	R6.50	9.50	12.30

REEL	Reel Size	Box	Box Size(mm)	Carton	Carton Size(mm)	G.W.(kg)
3000 pcs	7 inch	45,000 pcs	203×203×195	180,000 pcs	438×438×220	

Soldering Parameters

Reflow Condition		Pb – Free assembly
Pre Heat	Temperature Min ($T_{s(min)}$)	150°C
	Temperature Max ($T_{s(max)}$)	200°C
	Time (min to max) (t_s)	60 – 190 secs
Average ramp up rate (Liquidus Temp) (T_L) to peak		5°C/second max
		5°C/second max
Reflow	Temperature (T_L) (Liquidus)	217°C
	Temperature (t_L)	60 – 150 seconds
		260+0/-5 °C
Time within actual peak Temperature (t_p)		20 – 40 seconds
Ramp-down Rate		5°C/second max
Time 25°C to peak Temperature (T_P)		8 minutes Max.
Do not exceed		280°C

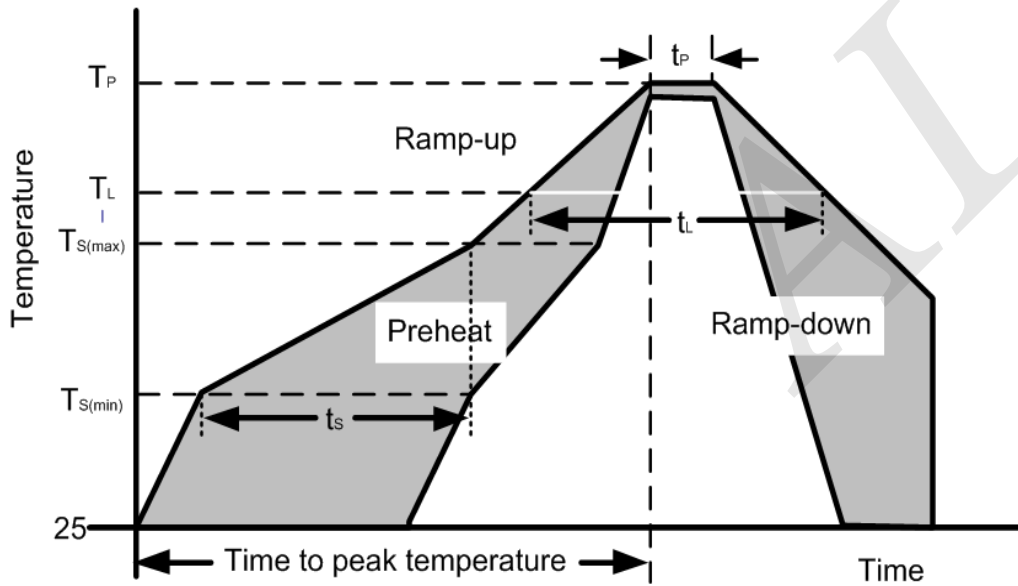

X-ON Electronics

Largest Supplier of Electrical and Electronic Components

Click to view similar products for [ALJ](#) manufacturer:

Other Similar products are found below :

[S8050D331](#) [MMBT431LT1](#) [S9018G331](#) [78L05\(SOT-89\)](#) [AMS1117-3.3\(SOT-89\)](#) [2N2907A-338](#) [2SB1132](#) [2SD882](#) [79L12](#) [AMS1117-1.2](#)
[AMS1117-1.8](#) [AMS1117-ADJ](#) [78L12](#) [A92H331](#) [D1616AGC929](#) [2N4401052](#) [ALJ13003-72](#) [C2001L011](#) [2N5551H-98](#) [A42H331](#)
[S9014C331](#) [S8550D331](#) [S9015C331](#) [2N5401H-98](#) [2N4403052](#) [C1008Y338](#) [ALJD882P01](#) [ALJA1300](#) [KSP10-061](#) [ALJ13001](#) [S9018H331](#)
[SS8050D331](#) [D965R011](#) [ALJ13002](#) [SS8550D331](#) [ALJB772P01](#) [BCX56-16](#) [SS8050](#) [2SD965](#) [CXT5551](#) [2SB1188-R](#) [2SB1189](#) [2SA1213](#)
[SS8550](#) [79L05](#) [XL1225](#) [ALJTL431A](#) [AMS1117-2.5](#) [AO3401](#) [S8050\(J3Y\)](#)