



## Hall-Effect Latch / Bipolar Switch

### FEATURES AND BENEFITS

- AEC-Q100 automotive qualified
- Quality managed (QM), ISO 26262:2011 compliant
- High-speed 4-phase chopper stabilization
- Low operating voltage down to 3 V
- High sensitivity
- Stable switchpoints
- Robust EMC

### PACKAGES:

3-Pin SOT23W  
(suffix LH)

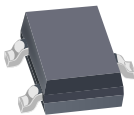

3-Pin SIP  
(suffix UA)



*Not to scale*

### DESCRIPTION

The A1250 Hall-effect sensor IC is a temperature-stable, stress-resistant bipolar switch. This device is the most sensitive Hall-effect device in the Allegro™ bipolar switch family and is intended for ring-magnet sensing. Superior high-temperature performance is made possible through an Allegro dynamic offset cancellation that utilizes chopper stabilization. This method reduces the offset voltage normally caused by device overmolding, temperature dependencies, and thermal stress.

The A1250 includes the following on a single silicon chip: a voltage regulator, Hall-voltage generator, small-signal amplifier, chopper stabilization, Schmitt trigger, and a short-circuit-protected open-drain output. Advanced BiCMOS wafer fabrication processing takes advantage of low-voltage requirements, component matching, very low input-offset errors, and small component geometries.

The A1250 Hall-effect bipolar switch turns on in a south polarity magnetic field of sufficient strength and switches off in a north polarity magnetic field of sufficient strength. Because the output state is not defined if the magnetic field is diminished or removed, to ensure that the device switches, Allegro recommends using magnets of both polarities and of sufficient strength in the application.

The A1250 is rated for operation in the ambient temperature range L,  $-40^{\circ}\text{C}$  to  $150^{\circ}\text{C}$ . Two package styles provide magnetically optimized solutions for most applications. Each package is lead (Pb) free version, with 100% matte-tin-plated leadframe.

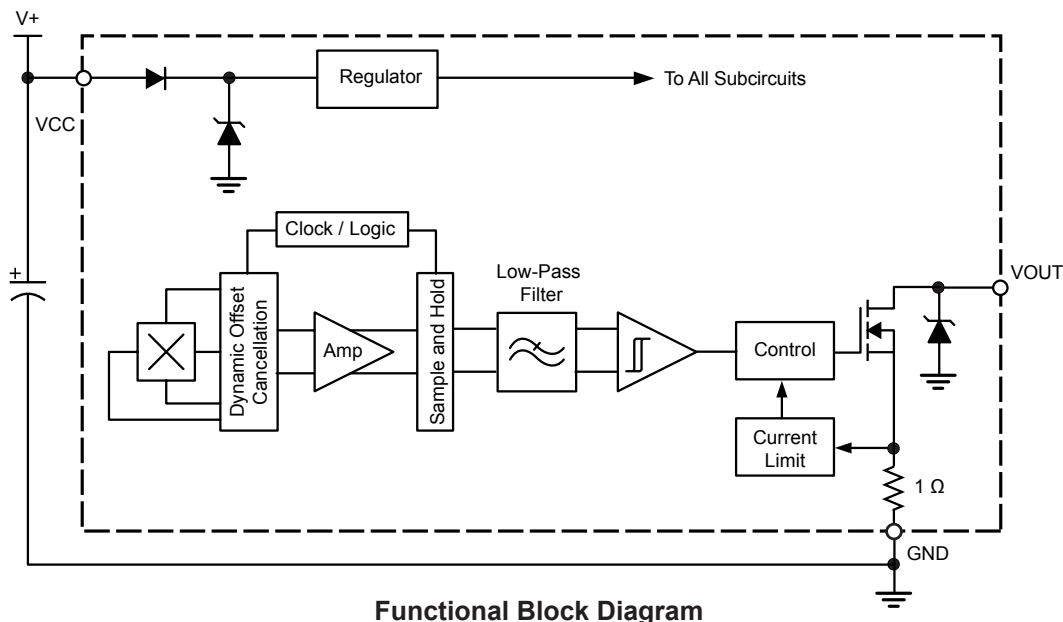

Functional Block Diagram

## SPECIFICATIONS

### SELECTION GUIDE

Part Number	Packing [1]	Mounting	Ambient, $T_A$ (°C)
A1250LLHLT-T	7-in. reel, 3,000 pieces/reel	Surface mount	-40 to 150
A1250LLHLX-T	13-in. reel, 10,000 pieces/reel	Surface mount	
A1250LUA-T	Bulk, 500 pieces/bag	SIP through hole	



[1] Contact Allegro for additional packing options.

### ABSOLUTE MAXIMUM RATINGS

Characteristic	Symbol	Notes	Rating	Unit [2]
Forward Supply Voltage [3]	$V_{CC}$		28	V
Reverse Supply Voltage [3]	$V_{RCC}$		-18	V
Output Off Voltage [3]	$V_{OUT}$		28	V
Reverse Output Voltage [3]	$V_{ROUT}$		-0.6	V
Output Current	$I_{OUTSINK}$		Internally limited	A
Reverse Output Current	$I_{ROUT}$		-10	mA
Magnetic Flux Density [4]	B		Unlimited	G
Operating Ambient Temperature	$T_A$	Range L	-40 to 150	°C
Maximum Junction Temperature	$T_{J(max)}$		165	°C
Storage Temperature	$T_{stg}$		-65 to 170	°C

[2] 1 G (gauss) = 0.1 mT (millitesla).

[3] This rating does not apply to extremely short voltage transients such as Load Dump and/or ESD. Those events have individual ratings, specific to the respective transient voltage event.

[4] Guaranteed by design.

## PINOUT DIAGRAMS AND TERMINAL LIST TABLE

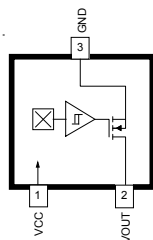

Package LH

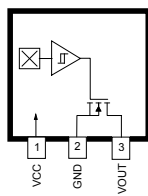

Package UA

Terminal List Table

Name	Number		Function
	Package LH	Package UA	
VCC	1	1	Device supply
VOUT	2	3	Device output
GND	3	2	Ground

**OPERATING CHARACTERISTICS:** Valid at  $T_A = -40^\circ\text{C}$  to  $150^\circ\text{C}$ ,  $C_{\text{BYPASS}} = 0.1 \mu\text{F}$ , unless otherwise noted

Characteristic	Symbol	Test Conditions	Min.	Typ.	Max.	Unit
<b>ELECTRICAL CHARACTERISTICS</b>						
Supply Voltage	$V_{\text{CC}}$	Operating $T_J < 165^\circ\text{C}$	3.0	–	24	V
Output Leakage Current	$I_{\text{OUTOFF}}$	$V_{\text{OUT}} = 24 \text{ V}$ , $B < B_{\text{RP}}$	–	–	10	$\mu\text{A}$
Output On Voltage	$V_{\text{OUT(SAT)}}$	$I_{\text{OUT}} = 20 \text{ mA}$ , $B > B_{\text{OP}}$	–	–	500	mV
Output Current Limit	$I_{\text{OM}}$	$B > B_{\text{OP}}$	30	–	60	mA
Power-On Time	$t_{\text{PO}}$	$V_{\text{CC}} > 3.0 \text{ V}$	–	–	25	$\mu\text{s}$
Chopping Frequency	$f_c$		–	160	–	kHz
Output Rise Time <sup>[1]</sup>	$t_r$	$R_{\text{LOAD}} = 820 \Omega$ , $C_S = 20 \text{ pF}$	–	–	2	$\mu\text{s}$
Output Fall Time <sup>[1]</sup>	$t_f$	$R_{\text{LOAD}} = 820 \Omega$ , $C_S = 20 \text{ pF}$	–	–	2	$\mu\text{s}$
Supply Current	$I_{\text{CCON}}$	$B > B_{\text{OP}}$	–	–	4	mA
	$I_{\text{CCOFF}}$	$B < B_{\text{RP}}$	–	–	4	mA
Reverse Battery Current	$I_{\text{RCC}}$	$V_{\text{RCC}} = -18 \text{ V}$	–	–	-2	mA
Supply Zener Clamp Voltage	$V_Z$	$I_{\text{CC}} = 6.5 \text{ mA}$ , $T_A = 25^\circ\text{C}$	28	–	–	V
Supply Zener Current	$I_Z$	$V_{\text{CC}} = 28 \text{ V}$	–	–	7	mA
<b>MAGNETIC CHARACTERISTICS <sup>[2]</sup>:</b> Valid at $T_A = -40^\circ\text{C}$ to $150^\circ\text{C}$ , $T_J \leq T_J(\text{max})$ , unless otherwise noted						
Operate Point	$B_{\text{OP}}$		-10	5	25	G
Release Point	$B_{\text{RP}}$		-25	-5	10	G
Hysteresis	$B_{\text{HYS}}$		5	10	25	G

<sup>[1]</sup> Guaranteed by design.

<sup>[2]</sup> Magnetic flux density, B, is indicated as negative value for north-polarity fields, and positive for south-polarity fields.

**THERMAL CHARACTERISTICS: May require derating at maximum conditions; see application information**

Characteristic	Symbol	Test Conditions*	Value	Units
Package Thermal Resistance	$R_{\theta JA}$	Package LH, 1-layer PCB with copper limited to solder pads	228	$^{\circ}\text{C}/\text{W}$
		Package LH, 2-layer PCB with 0.463 in. <sup>2</sup> of copper area each side connected by thermal vias	110	$^{\circ}\text{C}/\text{W}$
		Package UA, 1-layer PCB with copper limited to solder pads	165	$^{\circ}\text{C}/\text{W}$

\*Additional thermal information available on Allegro Web site.

**Power Derating Curve**

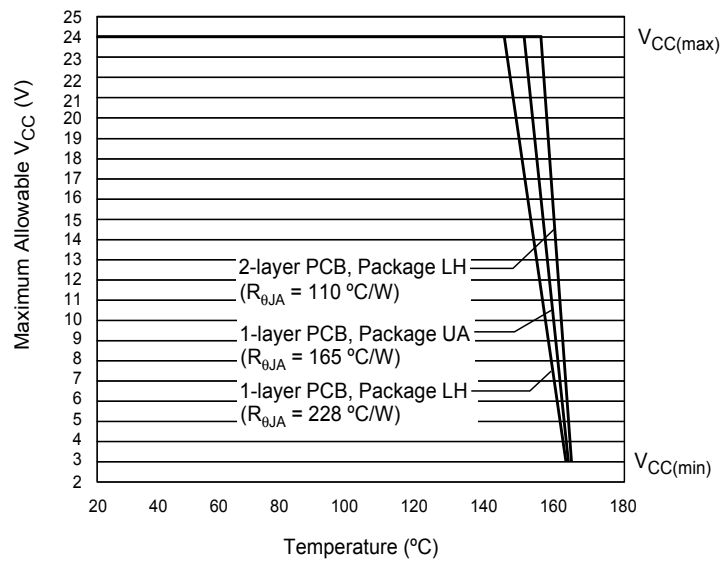

**Power Dissipation versus Ambient Temperature**

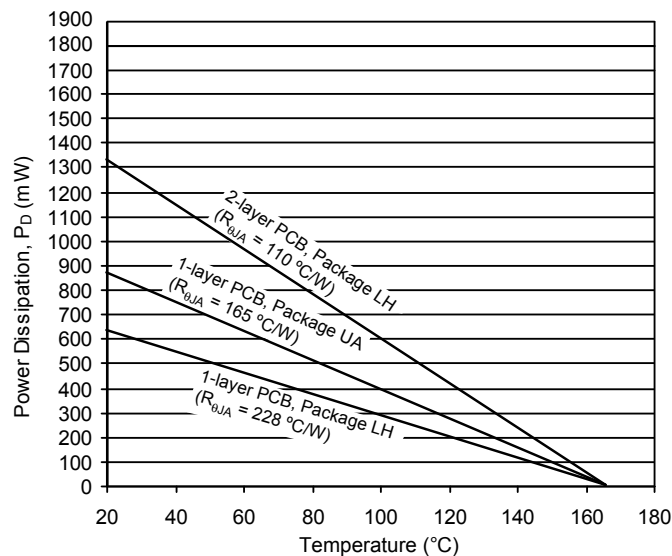

CHARACTERISTIC PERFORMANCE DATA

Supply Current (On) versus Supply Voltage

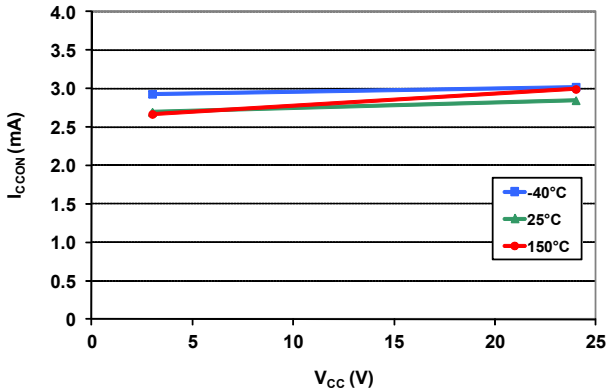

Supply Current (On) versus Ambient Temperature

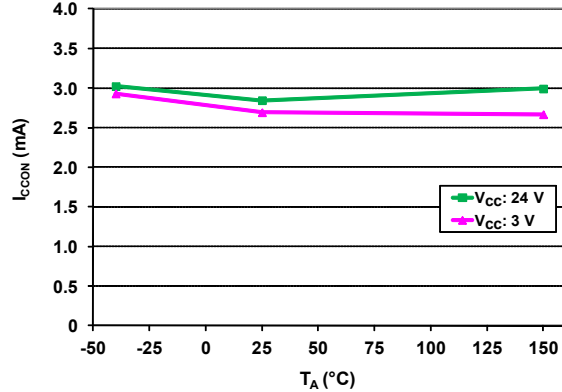

Supply Current (Off) versus Supply Voltage

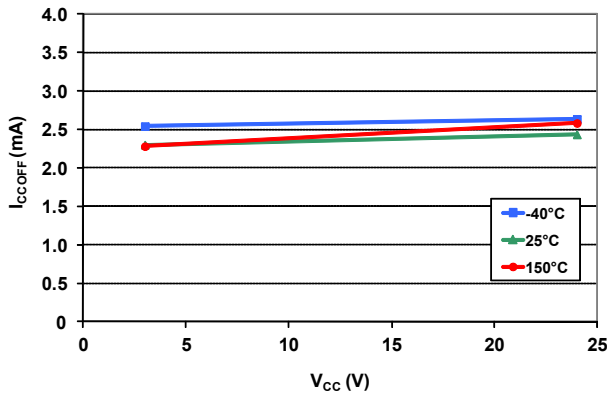

Supply Current (Off) versus Ambient Temperature

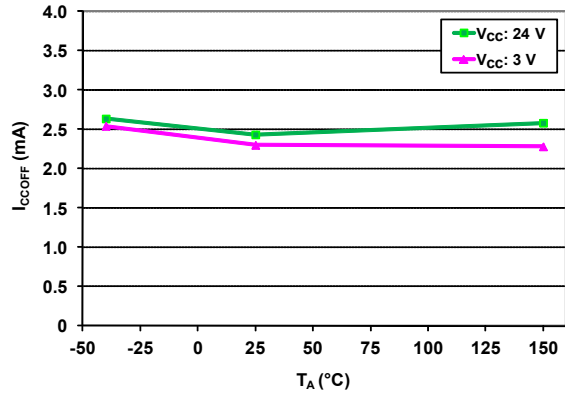

$V_{OUT(SAT)}$  versus Ambient Temperature  
 $I_{OUT} = 20$  mA

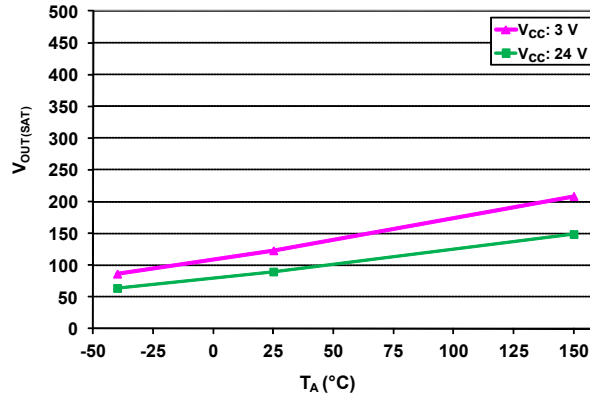

Operate Point versus Ambient Temperature

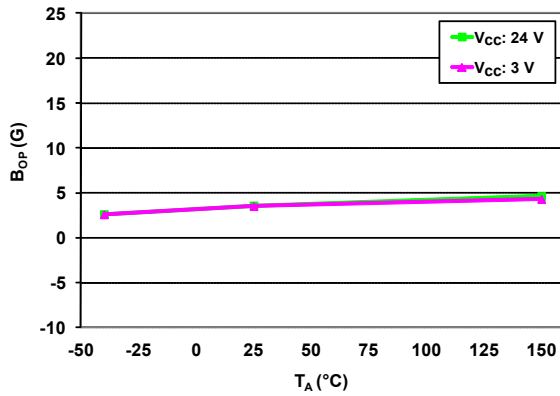

Release Point versus Ambient Temperature

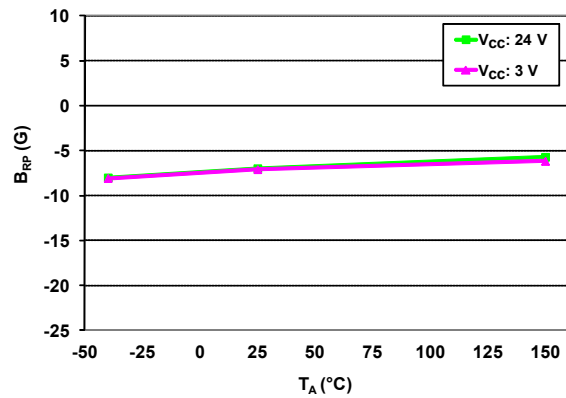

Hysteresis versus Ambient Temperature

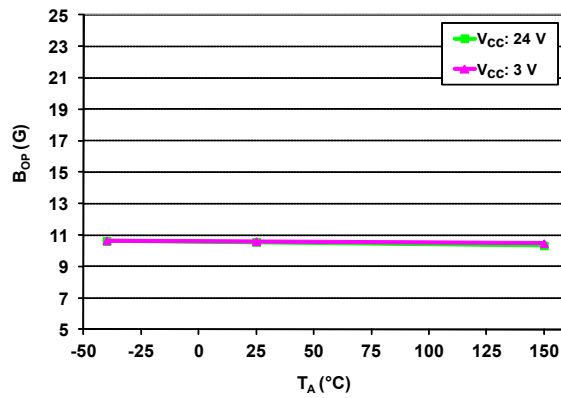

## FUNCTIONAL DESCRIPTION

The output of this device switches low (turns on) when a magnetic field perpendicular to the Hall sensor IC exceeds the operate point threshold,  $B_{OP}$ . After turn-on, the output voltage is  $V_{OUT(SAT)}$ . The output transistor is capable of sinking current up to the short circuit current limit  $I_{OM}$ , which is a minimum of 30 mA. When the magnetic field is reduced below the release point,  $B_{RP}$ , the device output goes high (turns off). The difference in the magnetic operate and release points is the hysteresis,  $B_{HYS}$ , of the device. This built-in hysteresis allows clean switching of the output even in the presence of external mechanical vibration and electrical noise.

Given the magnetic parameter specifications (refer to Magnetic Characteristics table), bipolar switches will operate in one of three modes, depending on switchpoints. For typical values of  $B_{OP}$  and  $B_{RP}$ , the device will operate as a latch, as shown in figure 1a. Note that, when the magnetic flux density exceeds a switchpoint, the output will retain its state when the magnetic field is removed. The other two modes of operation are the uni-

polar switch and the negative switch, shown in panels 1b and 1c, respectively. The unipolar switch type operates only in a south polarity field, and will switch to the high state if the magnetic field is removed. The negative switch operates only in a north polarity field, and will switch to the low state if the magnetic field is removed.

Individual bipolar switch devices exhibit any one of the three switching behaviors: latch, unipolar, or negative switch. Because these devices are not guaranteed to behave as latches, magnetic fields of sufficient magnitude and alternate polarity are required to ensure output switching.

Powering up the device in the hysteresis band, that is in a magnetic field less than  $B_{OP}$  and higher than  $B_{RP}$ , allows an indeterminate output state. Note that this hysteresis band encompasses zero magnetic field on devices that exhibit latch behaviors. The correct state is determined after the first magnetic excursion beyond  $B_{OP}$  or  $B_{RP}$ .

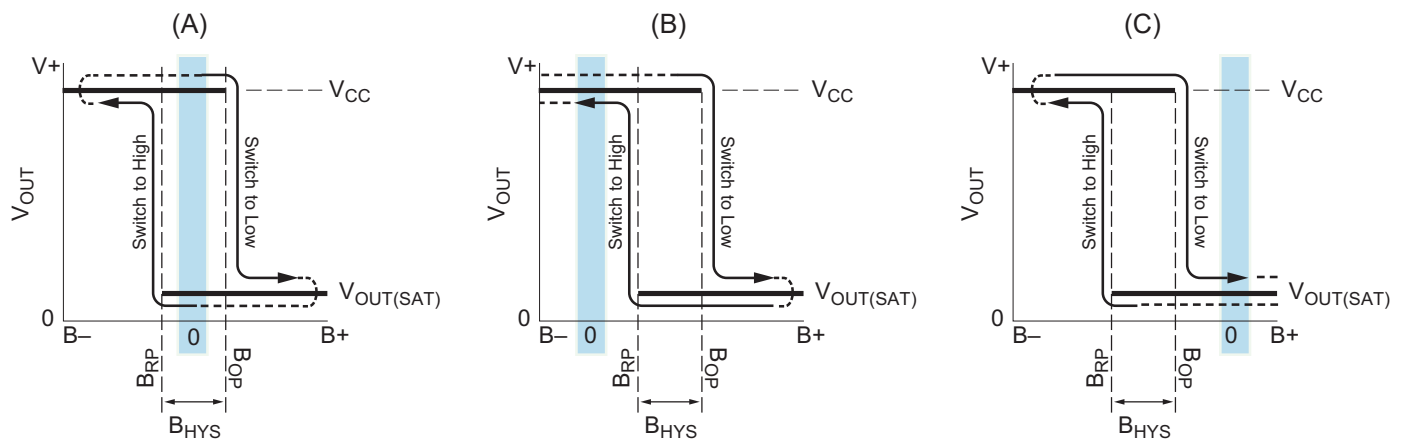

Figure 1: Bipolar Device Output Switching Modes

These behaviors can be exhibited when using a circuit such as that shown in figure 1. Panel A displays the hysteresis when a device exhibits latch mode (note that the  $B_{HYS}$  band incorporates  $B = 0$ ), panel B shows unipolar switch behavior (the  $B_{HYS}$  band is more positive than  $B = 0$ ), and panel C shows negative switch behavior (the  $B_{HYS}$  band is more negative than  $B = 0$ ). Bipolar devices, such as the A1250, can operate in any of the three modes.

APPLICATION INFORMATION

Functional Safety

The A1250 complies with the international standard for automotive functional safety, ISO 26262:2011, as a Quality Managed (QM) product. The device is classified as a SEooC (Safety Element out of Context) and can be easily integrated into safety-critical systems requiring higher ASIL ratings that incorporate external diagnostics or use measures such as redundancy. Safety documentation will be provided to support and guide the integration process. For further information, contact your local Allegro field applications engineer or sales representative.

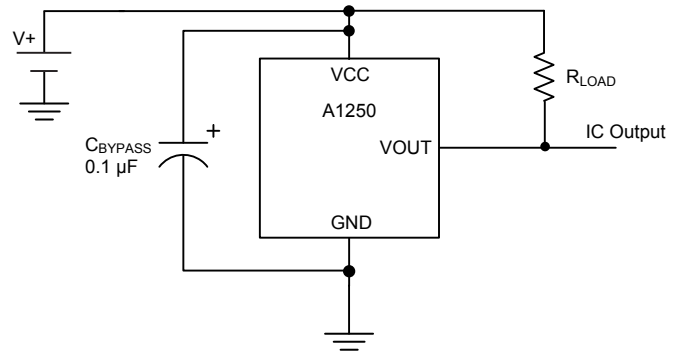

Figure 2: Typical Application Circuit

Chopper Stabilization Technique

When using Hall-effect technology, a limiting factor for switchpoint accuracy is the small signal voltage developed across the Hall element. This voltage is disproportionally small relative to the offset that can be produced at the output of the Hall sensor IC. This makes it difficult to process the signal while maintaining an accurate, reliable output over the specified operating temperature and voltage ranges. Chopper stabilization is a unique approach used to minimize Hall offset on the chip. Allegro employs a technique to remove key sources of the output drift induced by thermal and mechanical stresses. This offset reduction technique is based on a signal modulation-demodulation process. The undesired offset signal is separated from the magnetic field-induced signal in the frequency domain, through modulation. The subsequent demodulation acts as a modulation process for the offset, causing the magnetic field-induced signal to recover its original spectrum at base band, while the DC offset becomes a high-frequency signal. The magnetic-sourced signal then can

pass through a low-pass filter, while the modulated DC offset is suppressed. In addition to the removal of the thermal and stress related offset, this novel technique also reduces the amount of thermal noise in the Hall sensor IC while completely removing the modulated residue resulting from the chopper operation. The chopper stabilization technique uses a high frequency sampling clock. For demodulation process, a sample and hold technique is used. This high-frequency operation allows a greater sampling rate, which results in higher accuracy and faster signal-processing capability. This approach desensitizes the chip to the effects of thermal and mechanical stresses, and produces devices that have extremely stable quiescent Hall output voltages and precise recoverability after temperature cycling. This technique is made possible through the use of a BiCMOS process, which allows the use of low-offset, low-noise amplifiers in combination with high-density logic integration and sample-and-hold circuits.

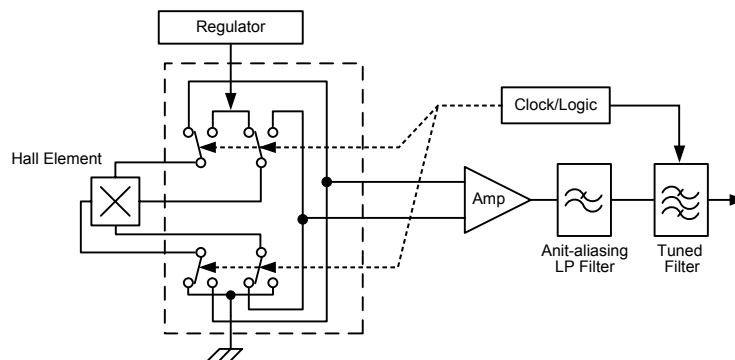

Figure 3: Concept of Chopper Stabilization Technique



## POWER DERATING

The device must be operated below the maximum junction temperature of the device,  $T_{J(max)}$ . Under certain combinations of peak conditions, reliable operation may require derating supplied power or improving the heat dissipation properties of the application. This section presents a procedure for correlating factors affecting operating  $T_J$ . (Thermal data is also available on the Allegro MicroSystems website.)

The Package Thermal Resistance,  $R_{\theta JA}$ , is a figure of merit summarizing the ability of the application and the device to dissipate heat from the junction (die), through all paths to the ambient air. Its primary component is the Effective Thermal Conductivity,  $K$ , of the printed circuit board, including adjacent devices and traces. Radiation from the die through the device case,  $R_{\theta JC}$ , is relatively small component of  $R_{\theta JA}$ . Ambient air temperature,  $T_A$ , and air motion are significant external factors, damped by overmolding.

The effect of varying power levels (Power Dissipation,  $P_D$ ), can be estimated. The following formulas represent the fundamental relationships used to estimate  $T_J$ , at  $P_D$ .

$$P_D = V_{IN} \times I_{IN} \quad (1)$$

$$\Delta T = P_D \times R_{\theta JA} \quad (2)$$

$$T_J = T_A + \Delta T \quad (3)$$

For example, given common conditions such as:  $T_A = 25^\circ\text{C}$ ,  $V_{IN} = 12\text{ V}$ ,  $I_{IN} = 4\text{ mA}$ , and  $R_{\theta JA} = 140^\circ\text{C/W}$ , then:

$$P_D = V_{IN} \times I_{IN} = 12\text{ V} \times 4\text{ mA} = 48\text{ mW}$$

$$\Delta T = P_D \times R_{\theta JA} = 48\text{ mW} \times 140^\circ\text{C/W} = 7^\circ\text{C}$$

$$T_J = T_A + \Delta T = 25^\circ\text{C} + 7^\circ\text{C} = 32^\circ\text{C}$$

A worst-case estimate,  $P_{D(max)}$ , represents the maximum allowable power level, without exceeding  $T_{J(max)}$ , at a selected  $R_{\theta JA}$  and  $T_A$ .

*Example:* Reliability for  $V_{CC}$  at  $T_A = 150^\circ\text{C}$ , package UA, using a single-layer PCB.

Observe the worst-case ratings for the device, specifically:  $R_{\theta JA} = 165^\circ\text{C/W}$ ,  $T_{J(max)} = 165^\circ\text{C}$ ,  $V_{CC(max)} = 24\text{ V}$ , and  $I_{CC(max)} = 4\text{ mA}$ .

Calculate the maximum allowable power level,  $P_{D(max)}$ . First, invert equation 3:

$$\Delta T_{max} = T_{J(max)} - T_A = 165^\circ\text{C} - 150^\circ\text{C} = 15^\circ\text{C}$$

This provides the allowable increase to  $T_J$  resulting from internal power dissipation. Then, invert equation 2:

$$P_{D(max)} = \Delta T_{max} \div R_{\theta JA} = 15^\circ\text{C} \div 165^\circ\text{C/W} = 91\text{ mW}$$

Finally, invert equation 1 with respect to voltage:

$$V_{CC(est)} = P_{D(max)} \div I_{CC(max)} = 91\text{ mW} \div 4\text{ mA} = 23\text{ V}$$

The result indicates that, at  $T_A$ , the application and device can dissipate adequate amounts of heat at voltages  $\leq V_{CC(est)}$ .

Compare  $V_{CC(est)}$  to  $V_{CC(max)}$ . If  $V_{CC(est)} \leq V_{CC(max)}$ , then reliable operation between  $V_{CC(est)}$  and  $V_{CC(max)}$  requires enhanced  $R_{\theta JA}$ . If  $V_{CC(est)} \geq V_{CC(max)}$ , then operation between  $V_{CC(est)}$  and  $V_{CC(max)}$  is reliable under these conditions.

PACKAGE OUTLINE DRAWINGS

For Reference Only – Not for Tooling Use

(Reference MCO-000055)

Dimensions in millimeters – NOT TO SCALE

Dimensions exclusive of mold flash, gate burrs, and dambar protrusions  
Exact case and lead configuration at supplier discretion within limits shown

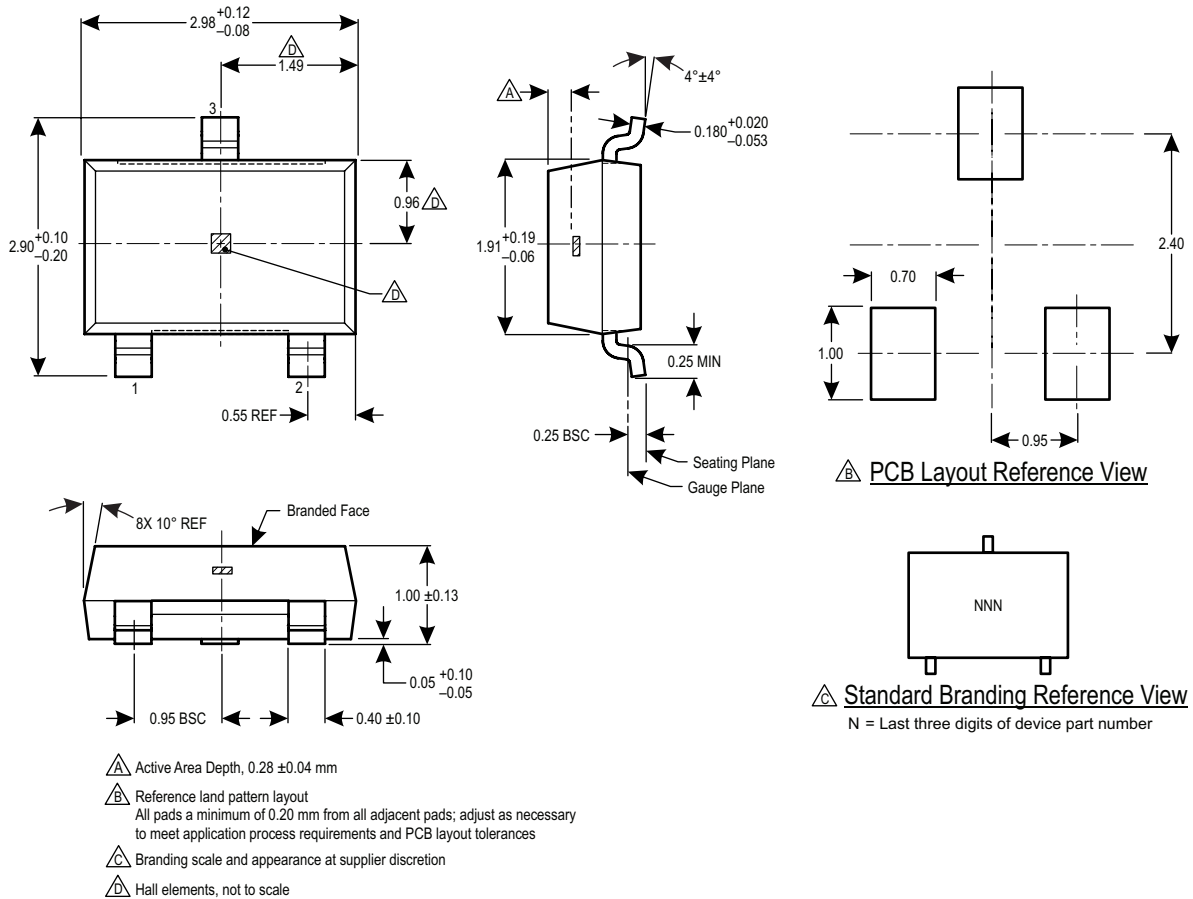

Figure 4: Package LH, 3-Pin SOT23W

For Reference Only – Not for Tooling Use

(Reference DWG-0000404, Rev. 1)

NOT TO SCALE

Dimensions in millimeters

Dimensions exclusive of mold flash, gate burrs, and dambar protrusions  
Exact case and lead configuration at supplier discretion within limits shown

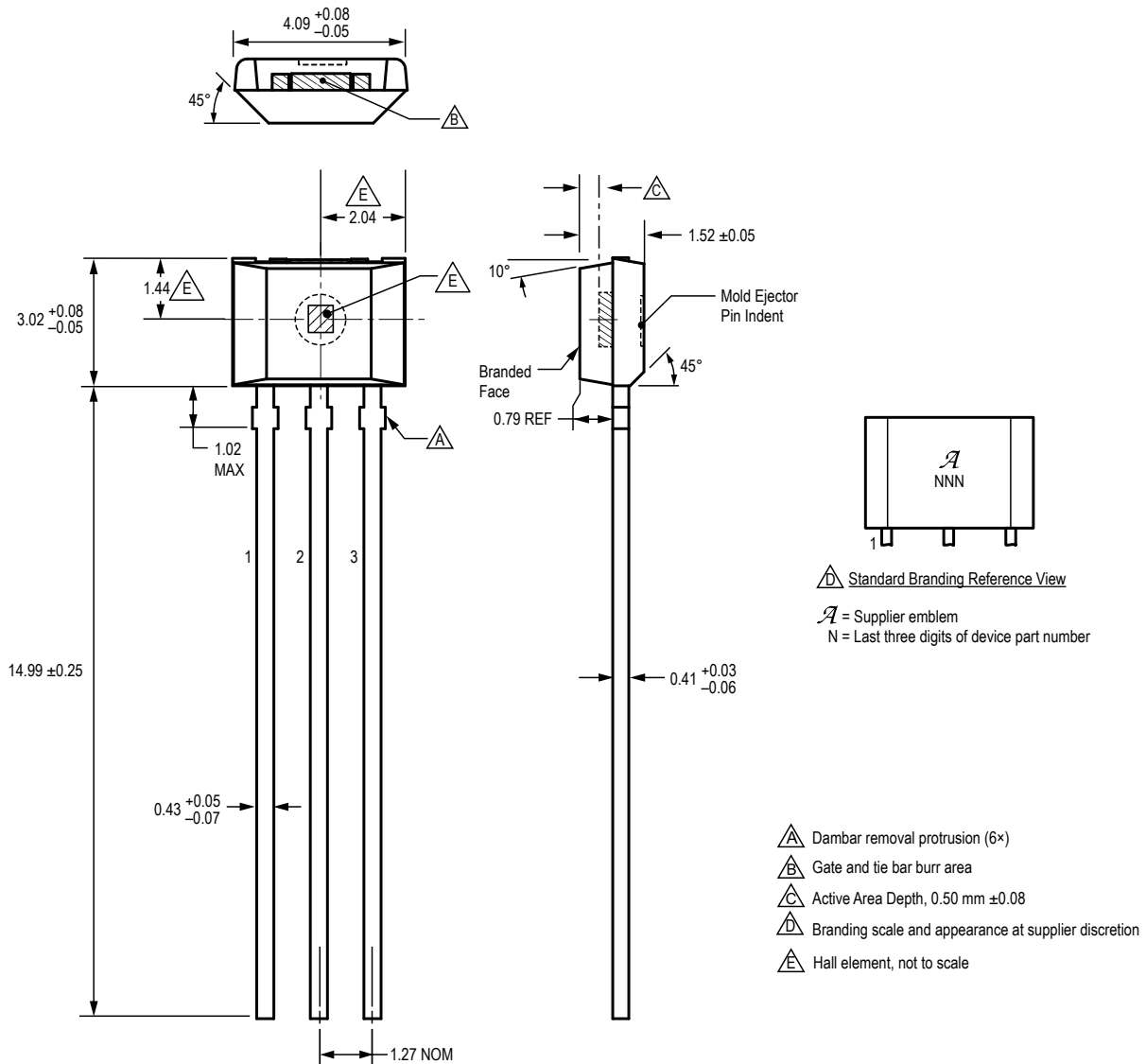

Figure 5: Package UA, 3-Pin SIP

**Revision History**

<b>Number</b>	<b>Date</b>	<b>Description</b>
1	March 22, 2012	Update product selection
2	October 29, 2014	Corrected tolerance on Package Outline Drawing
3	February 4, 2015	Corrected dimension on Package Drawing
4	September 21, 2015	Added AEC-Q100 qualification under Features and Benefits
5	September 26, 2017	Added Functional Safety information; added footnote to Absolute Maximum Ratings table
6	October 12, 2018	Added footnote to Magnetic Flux Density (page 2); minor editorial updates.

Copyright ©2018, Allegro MicroSystems, LLC

Allegro MicroSystems, LLC reserves the right to make, from time to time, such departures from the detail specifications as may be required to permit improvements in the performance, reliability, or manufacturability of its products. Before placing an order, the user is cautioned to verify that the information being relied upon is current.

Allegro's products are not to be used in any devices or systems, including but not limited to life support devices or systems, in which a failure of Allegro's product can reasonably be expected to cause bodily harm.

The information included herein is believed to be accurate and reliable. However, Allegro MicroSystems, LLC assumes no responsibility for its use; nor for any infringement of patents or other rights of third parties which may result from its use.

Copies of this document are considered uncontrolled documents.

*For the latest version of this document, visit our website:*

[www.allegromicro.com](http://www.allegromicro.com)

## X-ON Electronics

Largest Supplier of Electrical and Electronic Components

*Click to view similar products for [Motor/Motion/Ignition Controllers & Drivers](#) category:*

*Click to view products by [Allegro](#) manufacturer:*

Other Similar products are found below :

[LV8133JA-ZH](#) [LV8169MUTBG](#) [LV8774Q-AH](#) [LV8860PV-TLM-H](#) [MC33931EKR2](#) [MC34GD3000EP](#) [FSB50250UTD](#) [FSB50550TB2](#)  
[FSBF15CH60BTH](#) [MP6507GR-P](#) [MP6508GF](#) [MSVCPM2-63-12](#) [MSVGW45-14-2](#) [MSVGW54-14-5](#) [NTE7043](#) [CAT3211MUTAG](#)  
[LA6245P-CL-TLM-E](#) [LA6245P-TLM-E](#) [LA6565VR-TLM-E](#) [LB11650-E](#) [LB1694N-E](#) [LB1837M-TLM-E](#) [LB1845DAZ-XE](#) [LC898111AXB-](#)  
[MH](#) [LC898300XA-MH](#) [SS30-TE-L-E](#) [STK531-345A-E](#) [STK581U3A0D-E](#) [STK58AUNP0D-E](#) [STK621-068C-E](#) [STK621-140C](#) [STK621-](#)  
[728S-E](#) [STK625-728-E](#) [STK672-400B-E](#) [STK672-432AN-E](#) [STK672-432BN-E](#) [STK672-440AN-E](#) [STK672-442AN-E](#) [AMIS30621AUA](#)  
[FSB50550ASE](#) [26700](#) [LV8161MUTAG](#) [LV8281VR-TLM-H](#) [LV8702V-TLM-H](#) [LV8734VZ-TLM-H](#) [LV8773Z-E](#) [LV8807QA-MH](#)  
[MC33932EK](#) [MCP8024T-H/MP](#) [TND027MP-AZ](#)