Hall Effect Direction Detection Sensor

Discontinued Product

This device is no longer in production. The device should not be purchased for new design applications. Samples are no longer available.

Date of status change: November 2, 2009

Recommended Substitutions:

For existing customer transition, and for new customers or new applications, contact Allegro Sales.

NOTE: For detailed information on purchasing options, contact your local Allegro field applications engineer or sales representative.

Allegro MicroSystems, Inc. reserves the right to make, from time to time, revisions to the anticipated product life cycle plan for a product to accommodate changes in production capabilities, alternative product availabilities, or market demand. The information included herein is believed to be accurate and reliable. However, Allegro MicroSystems, Inc. assumes no responsibility for its use; nor for any infringements of patents or other rights of third parties which may result from its use.

Low-Voltage Full-Bridge Brushless DC Motor Driver with Hall Element Commutation

Features and Benefits

- Single-chip solution for high reliability
- Chopper stabilization technique for precise signal response over operating range
- 2.0 to 4.0 V operation
- Sleep mode pin allowing external logic signal enable/disable to reduce average power consumption
- Restart feature
- Small package size

Package: 6 Contact MLP/DFN/SO8 (suffix EL)

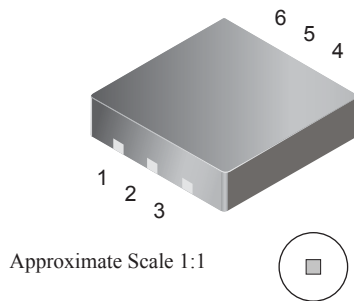

Description

The A1441 is a full-bridge motor driver designed to drive low-voltage bipolar brushless DC motors. Commutation of the motor is achieved by use of a single Hall element to detect the position of an alternating-pole ring magnet. A high density merged Bipolar-CMOS semiconductor process allows the integration of the Hall element on the same IC as the motor control circuitry, providing a single-chip solution for enhanced reliability. All necessary circuitry is incorporated within the device package, eliminating the need for any external support components.

A micropower sleep mode can be enabled by an external signal, to reduce current consumption for battery management in portable electronic devices. In addition, the device offers an active function for motor braking.

The A1441 is optimized for vibration motor applications such as cellular phones, pagers, electronic toothbrushes, and hand-held video game controllers. These devices also drive low power fan motors designed with cogging plates.

Continued on the next page...

Functional Block Diagram

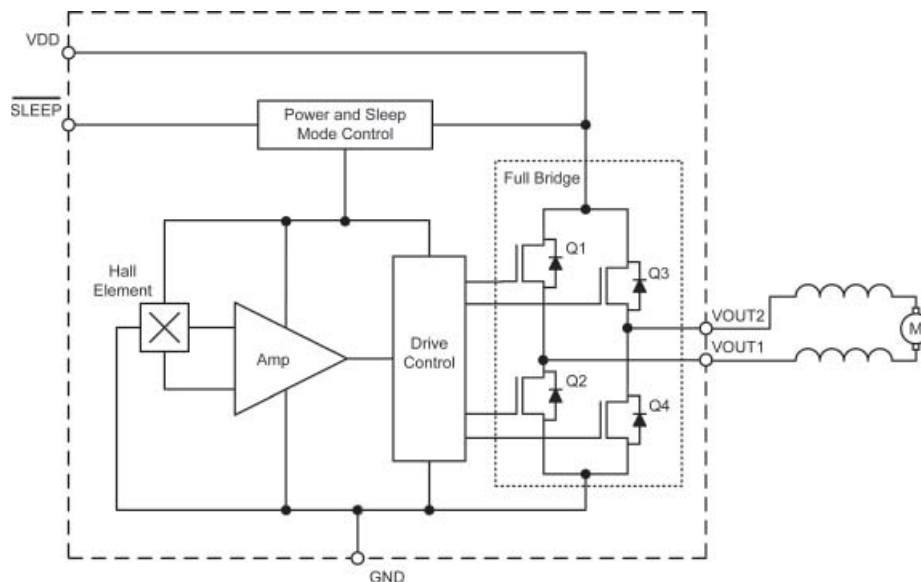

Description (continued)

The small package outlines and low profiles make this device ideally suited for use in applications where printed circuit board area and component headroom are at a premium. It is available in

a lead (Pb) free (leadframe plating 100% matte tin) 6-pin surface mount MLP (microleadframe: DFN) package, with exposed pad for enhanced thermal dissipation.

Selection Guide

Part Number	Package	Packing*
A1441EELLT-T	MLP 2x2 mm; 0.50 mm nom. height	3000 pieces/ 7-in. reel

*For additional packing options, contact Allegro.



Absolute Maximum Ratings

Characteristic	Symbol	Notes	Rating
Supply Voltage	V_{DD}		5.0 V
Reverse Battery Voltage	V_{RDD}		-0.3 V
Output Voltage	V_{OUT}		-0.3 V to $V_{DD} + 0.3$ V
Control Input Voltage	$V_{IN(High)}$		-0.3V to $V_{DD} + 0.3$ V
Load Current	I_{LOAD}	Positive I_{LOAD} flow is from VOUT1 to VOUT2	± 150 mA
Magnetic Flux Density	B		Unlimited
Operating Ambient Temperature	T_A	Range E	-40°C to 85°C
Maximum Junction	$T_J(max)$		165°C
Storage Temperature	T_{stg}		-65°C to 170°C

Pin-out Diagram

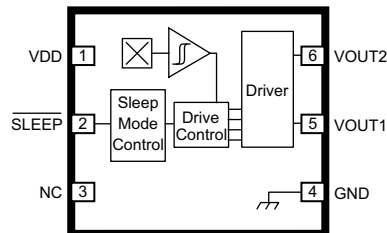

Terminal List Table

Name	Number	Function
	EL Package	
VDD	1	Supply voltage
SLEEP	2	Toggle Sleep/Enabled modes
NC	3	No connection
GND	4	Ground
VOUT1	5	First output
VOUT2	6	Second output

DEVICE CHARACTERISTICS over the voltage and temperature operating range, unless otherwise specified

Characteristics	Symbol	Test Conditions	Min.	Typ.	Max.	Units	
Supply Voltage	V_{DD}	Running	2.0	–	4.0	V	
Total Output Saturation Voltage ¹	$V_{OUT(Sat)}$	$I_{LOAD} = 100 \text{ mA}, V_{DD} = 3.6 \text{ V}$	–	–	500	mV	
		$I_{LOAD} = 70 \text{ mA}, V_{DD} = 2.2 \text{ V}$	–	–	400	mV	
Sleep Mode Supply Current	$I_{DD(Sleep)}$		–	–	10	μA	
Load Current Rise Time ²	$t_{r(ILOAD)}$	$V_{DD} = 3.6 \text{ V}$	–	10	–	μs	
Chopping Settling Time ³	$t_{s(CHOP)}$		–	30	–	μs	
$\overline{\text{SLEEP}}$ Input Threshold	V_{INLO}		–	–	0.5	V	
	V_{INHI}		$V_{DD}-0.7$	–	–	V	
$\overline{\text{SLEEP}}$ Input Current	I_{IN}		–	–	1	μA	
Crossover Dead Time ⁴	t_{DT}	VOUT switching	–	2	–	μs	
Restart Delay ⁵	t_{RS}		–	–	225	ms	
Magnetic Switchpoints	B_{OP}		–	35	75	G	
	B_{RP}		–75	–35	–	G	
	B_{HYS}	$B_{OP} - B_{RP}; B_{OP} > B_{RP}$	–	70	–	G	
Startup Polarity	V_{OUT1}	$B < B_{rp}$		LOW		–	
		$B > B_{op}$		HIGH		–	
	V_{OUT2}	$B < B_{rp}$			HIGH		–
		$B > B_{op}$			LOW		–

¹Either $V_{OUT(Sat)} = V_{Q1(Sat)} + V_{Q4(Sat)}$ or $V_{OUT(Sat)} = V_{Q2(Sat)} + V_{Q3(Sat)}$. Total output saturation voltage is a sum of the voltages across the active output transistors.

²Time period required for current to change from 10% to 90% of it's value.





³Chopping settling time is the required time to have valid device output after power up of the device.

⁴Crossover dead time is a time period during which all output transistors are switched off.

⁵Restart delay is a time period during which only one pair of the output transistors is switched on.

Package EL, 6 pin MLP/DFN/SOP

Preliminary dimensions, for reference only
 (JEDEC ultra-thin MQ-229UCCD, except contact layout)
 Dimensions in millimeters
 U.S. Customary dimensions (in.) in brackets, for reference only
 Dimensions exclusive of mold flash, gate burrs, and dambar protrusions
 Exact case and lead configuration at supplier discretion within limits shown

-  Terminal #1 mark area
-  Exposed thermal pad (reference only, terminal #1 identifier appearance at supplier discretion)
-  Reference land pattern layout: adjust as necessary to meet application process requirements and PCB layout tolerances; when mounting on a multilayer PCB, thermal vias at the exposed thermal pad land can improve thermal dissipation (reference EIA/JEDEC Standard JESD51-5)
-  Hall element (not to scale)
-  Active area depth

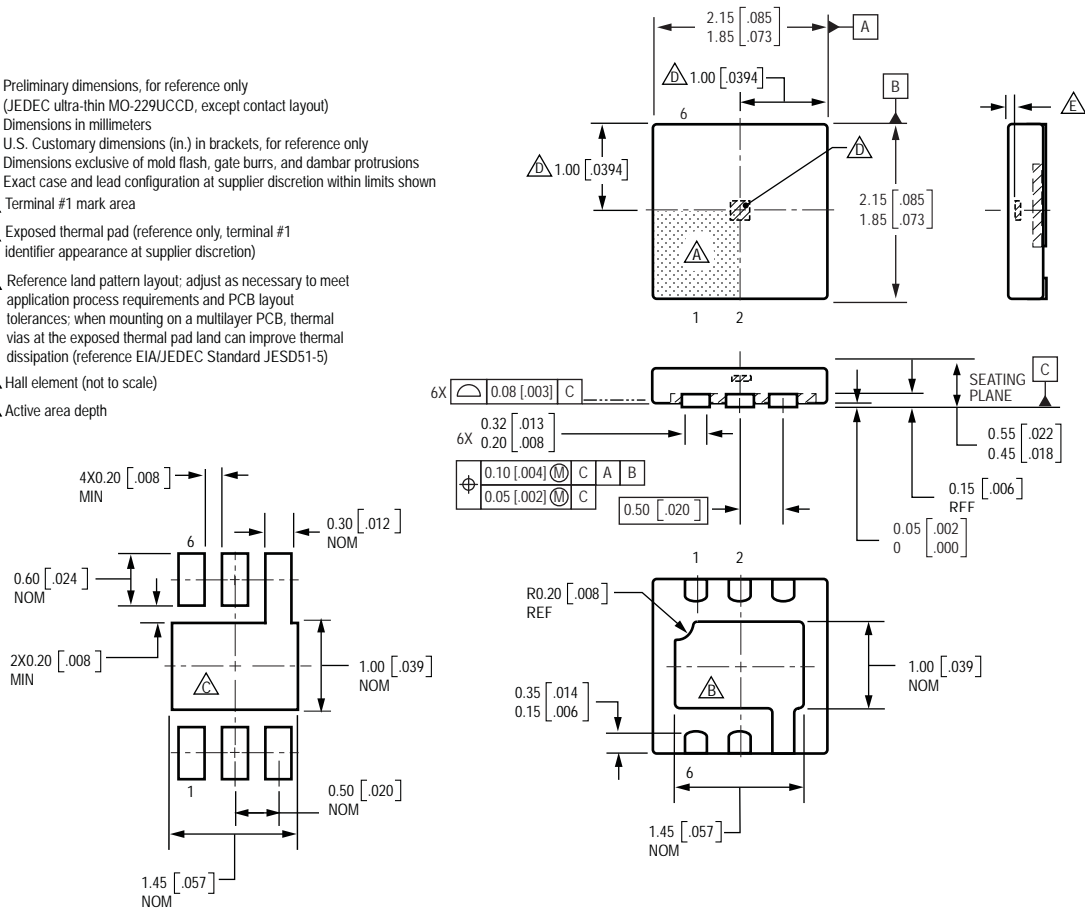

Copyright ©2005-2008, Allegro MicroSystems, Inc.

The products described herein are manufactured under one or more of the following U.S. patents: 5,045,920; 5,264,783; 5,442,283; 5,389,889; 5,581,179; 5,517,112; 5,619,137; 5,621,319; 5,650,719; 5,686,894; 5,694,038; 5,729,130; 5,917,320; and other patents pending.

Allegro MicroSystems, Inc. reserves the right to make, from time to time, such departures from the detail specifications as may be required to permit improvements in the performance, reliability, or manufacturability of its products. Before placing an order, the user is cautioned to verify that the information being relied upon is current.

Allegro's products are not to be used in life support devices or systems, if a failure of an Allegro product can reasonably be expected to cause the failure of that life support device or system, or to affect the safety or effectiveness of that device or system.

The information included herein is believed to be accurate and reliable. However, Allegro MicroSystems, Inc. assumes no responsibility for its use; nor for any infringement of patents or other rights of third parties which may result from its use.

For the latest version of this document, visit our website:

www.allegromicro.com



X-ON Electronics

Largest Supplier of Electrical and Electronic Components

Click to view similar products for [allegro manufacturer](#):

Other Similar products are found below :

[A1101ELHLT-T](#) [APEK4954ELP-01-T-DK](#) [APEK4491EES-01-T-DK](#) [APEK4490EES-01-T-DK](#) [ASEK758KCB-150U-T-DK](#) [ASEK759LCB-050B-T-DK](#) [APEK3901SEJ-01-T-DK](#) [APEK3931KJP-01-T-DK](#) [APEK4403GEU-01-T-DK](#) [ASEK711KLC-25AB-T-DK](#) [ACS714ELCTR-30A-T](#) [APS12235LUAABU](#) [A3981KLPTR-T](#) [A5985GETTR-T](#) [ACS724LLCTR-50AB-T](#) [APEK4952ELY-01-T-DK](#) [APEK4931MET-01-T-DK](#) [APEK4447SLJ-01-T-DK](#) [ASEK710KLA-6BB-T-DK](#) [ASEK758LCB-050B-T-DK](#) [ASEK770KCB-150U-T-DK](#) [APEK4985SLP-01-T-DK](#) [ASEK716KLA-12CB-T-DK](#) [A1212LLHLT-T](#) [A3213ELHLT-T](#) [A3916GESTR-T-1](#) [ACS758KCB-150B-PFF-T](#) [APEK4953ELJ-01-T-DK](#) [APEK4942GES-01-T-DK](#) [APEK3906SES-01-T-DK](#) [ASEK712ELC-30A-T-DK](#) [ASEK758ECB-200B-T-DK](#) [ASEK758LCB-100B-T-DK](#) [ASEK713ELC-20A-T-DK](#) [ASEK716KLA-25CB-T-DK](#) [ASEK759KCB-150B-T-DK](#) [ASEK770ECB-200U-T-DK](#) [A3930KJPTR-T](#) [APEK4979GLP-01-T-DK](#) [ASEK716KLA-6BB-T-DK](#) [ASEK758LCB-050U-T-DK](#) [A3959SLBTR-T](#) [ACS715ELCTR-30A-T](#) [APEK8651KLP-01-MH-DK](#) [APEK8650KLY-01-MH-DK](#) [APEK4915MLP](#) [ASEK710KLA-25CB-T-DK](#) [ASEK770ECB-200B-T-DK](#) [ASEK770KCB-150B-T-DK](#) [APEK4402KLP-01-T-DK](#)