Dual LNB Supply and Control Voltage Regulator

Pre-End-of-Life

This device is in production, however, it has been deemed Pre-End of Life. The product is approaching end of life. Within a minimum of 6 months, the device will enter its final, Last Time Buy, order phase.

Date of status change: December 5, 2018

Recommended Substitutions: [Generation 4 and 5 devices](#)

For existing customer transition, and for new customers or new applications, contact Allegro Sales.

NOTE: For detailed information on purchasing options, contact your local Allegro field applications engineer or sales representative.

Allegro MicroSystems, LLC reserves the right to make, from time to time, revisions to the anticipated product life cycle plan for a product to accommodate changes in production capabilities, alternative product availabilities, or market demand. The information included herein is believed to be accurate and reliable. However, Allegro MicroSystems, LLC assumes no responsibility for its use; nor for any infringements of patents or other rights of third parties which may result from its use.

Dual LNB Supply and Control Voltage Regulator

FEATURES AND BENEFITS

- Integrated boost MOSFET, current sensing, and compensation
- Stable with low-profile ceramic boost capacitors
- Adjustable LNB output current limit from 250 to 950 mA
 - Covers wide array of application requirements
 - Minimizes component sizing to fit each application
 - For startup, reconfiguration, and continuous output (maximum value depends on PCB thermal design)
- Boost peak current limit scales with LNBx current limit setting
- 8 programmable LNBx output voltage (DAC) levels
- LNBx overcurrent limiter with shutdown timer
- Static LNBx current limit reliably starts a wide range of loads
- Tracking boost converter minimizes power dissipation
- LNBx transition times configurable by external capacitor
- Push-pull LNBx output stage maintains 13→18 V and 18→13 V transition times, even with highly capacitive loads
- Built-in 22 kHz tone oscillator facilitates DiSEqC™ tone encoding, even at no-load

Continued on the next page...

PACKAGE: 28-contact QFN (suffix ET)

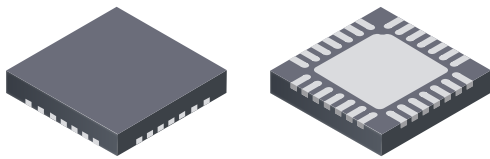

5 mm × 5 mm × 0.90 mm

DESCRIPTION

Intended for analog and digital satellite receivers, this dual low noise block converter regulator (LNBR) is a monolithic linear and switching voltage regulator, specifically designed to provide the power and the interface signals to an LNB down converter via coaxial cable. The A8299 requires few external components, with the boost switch and compensation circuitry integrated inside of the device. A high switching frequency is chosen to minimize the size of the passive filtering components, further assisting in cost reduction. The high levels of component integration ensure extremely low noise and ripple figures.

The A8299 has been designed for high efficiency, utilizing the Allegro™ advanced BCD process. The integrated boost switch has been optimized to minimize both switching and static losses. To further enhance efficiency, the voltage drop across the tracking regulator has been minimized.

For DiSEqC™ communications, a tone control pin is provided to gate the internally-generated 22 kHz tone on-and-off.

A comprehensive set of fault registers are provided, which comply with all the common standards, including: overcurrent, thermal shutdown, undervoltage, and power not good.

Furthermore, design methodology and structure ensure the highest level of robustness against transients and component failures. The device uses a 2-wire bidirectional serial interface, compatible with the I²C™ standard, that operates up to 400 kHz.

The A8299 is supplied in a lead (Pb) free package.

Functional Block Diagram

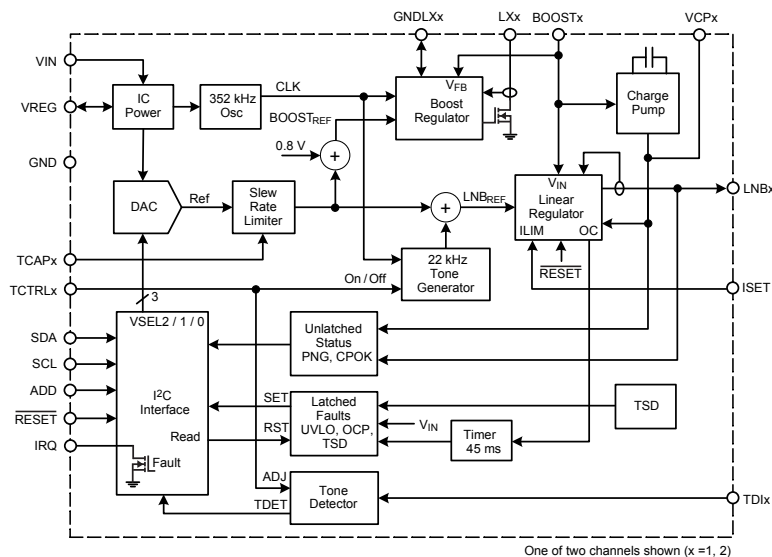

FEATURES AND BENEFITS (continued)

- Tone generation does not require additional external components
- Diagnostic features: PNGx, TDET_x
- Dynamic tone detect amplitude and frequency transmit/receive thresholds
- $\overline{\text{RESET}}$ input disables the LNB_x and resets all registers for fast load shedding
- Extensive protection features: UVLO, OCP_x, TSD, CPOK_x
- 2-wire I²C-compatible interface
- Small low-profile 5 mm × 5 mm, 0.90 mm QFN-28 package

SELECTION GUIDE

Part Number	Packing [1]	Description
A8299SETTR-T [2]	7 in. reel, 1500 pieces/reel 12 mm carrier tape	ET package, QFN surface mount 5 mm × 5 mm × 0.90 mm nominal height



[1] Contact Allegro for additional packing options.

[2] Leadframe plating 100% matte tin.

ABSOLUTE MAXIMUM RATINGS

Characteristic	Symbol	Conditions	Rating	Unit
Load Supply Voltage, VIN pin	V_{IN}		30	V
Output Current [3]	I_{OUT}		Internally Limited	A
Output Voltage, BOOST _x pin			-0.3 to 43	V
Output Voltage, LNB _x pin		Surge [4]	-1.0 to 43	V
Output Voltage, LX _x pin			-0.3 to 30	V
Output Voltage, VCP _x pin			-0.3 to 48	V
Logic Input Voltage			-0.3 to 5.5	V
Logic Output Voltage			-0.3 to 5.5	V
Operating Ambient Temperature	T_A	Range S	-20 to 85	°C
Junction Temperature	$T_J(\text{max})$		150	°C
Storage Temperature	T_{slg}		-55 to 150	°C

[3] Output current rating may be limited by duty cycle, ambient temperature, and heat sinking. Under any set of conditions, do not exceed the specified current ratings, or a junction temperature, T_J , of 150°C.

[4] See application schematics 3 and 4 on pages 24 and 25.

PACKAGE THERMAL CHARACTERISTICS [5]

Package	$R_{\theta JA}$ (°C/W)	PCB
ET	32	4-layer

[5] Additional information is available on the Allegro website.

Pinout Diagram

(Top View)

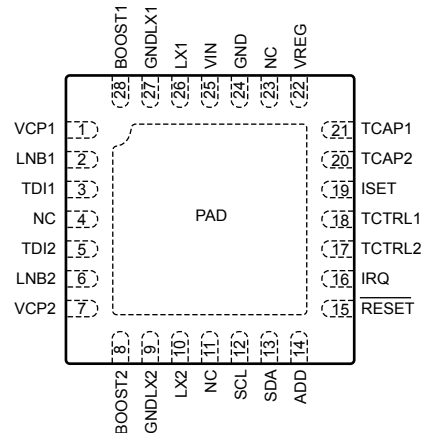

Terminal List Table

Name	Number	Function
ADD	14	Address select
BOOST1	28	Channel 1 tracking supply voltage to linear regulator
BOOST2	8	Channel 2 tracking supply voltage to linear regulator
GND	24	Signal ground
GNDLX1	27	Channel 1 boost switch ground
GNDLX2	9	Channel 1 boost switch ground
IRQ	16	Interrupt request
ISET	19	Output current limit set via external resistor
LNB1	2	Channel 1 output voltage to LNB
LNB2	6	Channel 2 output voltage to LNB
LX1	26	Channel 1 inductor drive point
LX2	10	Channel 2 inductor drive point
NC	4,11,23	No connection
PAD	Pad	Exposed pad; connect to the ground plane, for thermal dissipation
SCL	12	I ² C™-compatible clock input
SDA	13	I ² C™-compatible data input/output
TCAP1	21	Channel 1 capacitor for setting the rise and fall time of the LNB1 output
TCAP2	20	Channel 2 capacitor for setting the rise and fall time of the LNB2 output
TCTRL1	18	Channel 1 gates the 22 kHz tone on-and-off
TCTRL2	17	Channel 2 gates the 22 kHz tone on-and-off
TDI1	3	Channel 1 connect to output for 22 kHz tone verification function
TDI2	5	Channel 2 connect to output for 22 kHz tone verification function
RESET	15	Master reset input, active low
VCP1	1	Channel 1 gate supply voltage
VCP2	7	Channel 2 gate supply voltage
VIN	25	Supply input voltage
VREG	22	Analog supply

ELECTRICAL CHARACTERISTICS [1] at $T_A = 25^\circ\text{C}$, $V_{IN} = 10$ to 16 V, • as noted [2], unless noted otherwise

Characteristics	Symbol	Test Conditions	Min.	Typ.	Max.	Unit
GENERAL						
Output Voltage Accuracy	V_{OUT}	$V_{IN} = 12$ V, $I_{OUT} = 50$ mA, see table 3 for DAC settings	• -2	-	2	%
Load Regulation	$\Delta V_{OUT(Load)}$	$V_{IN} = 12$ V, $V_{OUT} = 13.667$ V, $\Delta I_{OUT} = 50$ to 700 mA	• -	75	120	mV
		$V_{IN} = 12$ V, $V_{OUT} = 19.000$ V, $\Delta I_{OUT} = 50$ to 700 mA	• -	85	150	mV
Line Regulation	$\Delta V_{OUT(Line)}$	$V_{IN} = 10$ to 16 V, $V_{OUT} = 13.667$ V, $\Delta I_{OUT} = 50$ mA	• -10	0	10	mV
		$V_{IN} = 10$ to 16 V, $V_{OUT} = 19.000$ V, $\Delta I_{OUT} = 50$ mA	• -10	0	10	mV
Supply Current	$I_{IN(OFF)}$	ENB1 bit and ENB2 bit = 0, or $\overline{RESET} = 0$, $V_{IN} = 12$ V	• -	5	10	mA
	$I_{IN(ON)}$	ENB1 bit and ENB2 bit = 1, $V_{IN} = 12$ V, $I_{LOAD} = 10$ mA, $V_{OUT} = 19$ V, TCTRLx = 0	• -	20	25	mA
		ENB1 bit and ENB2 bit = 1, $V_{IN} = 12$ V, $I_{LOAD} = 10$ mA, $V_{OUT} = 19$ V, TCTRLx = 1	• -	30	40	mA
Boost Switch On Resistance	$R_{DS(on) BOOST}$	$I_{SW} = 450$ mA	-	300	-	m Ω
Switching Frequency	f_{SW}		320	352	384	kHz
Linear Regulator Voltage Drop	ΔV_{REGx}	$V_{BOOSTx} - V_{LNBx}$, no tone signal, $I_{LOAD} = 700$ mA	600	800	1000	mV
TCAPx Pin Current	I_{TCAPx}	TCAP capacitor (CTCAPx) charging	-13	-10	-7	μA
		TCAP capacitor (CTCAPx) discharging	7	10	13	μA
Output Voltage Rise Time [3]	$t_{r(VLNB)x}$	$V_{LNBx} 13 \rightarrow 19$ V; $C_{TCAPx} = 100$ nF, $I_{LOAD} = 700$ mA	-	10	-	ms
Output Voltage Pull-Down Time [3]	$t_{f(VLNB)x}$	$V_{LNBx} 19 \rightarrow 13$ V; $C_{LOAD} = 100$ μF , $I_{LOAD} = 0$ mA	-	20	-	ms
LNBx Sink Current [3]	I_{RLNB}	ENBx = 0, $V_{LNBx} = 21$ V, Boost capacitor fully charged	-	2	4	mA
		ENBx = 1, $V_{SEL_{2,1,0}} = 001$ (13.667 V), $V_{LNBx} = 21$ V, TCTRLx = 0 or 1	-	9	15	mA
		ENBx = 1, $V_{SEL_{2,1,0}} = 101$ (19.000 V), $V_{LNBx} = 21$ V, TCTRLx = 0 or 1	-	9	15	mA
		ENBx = 1, $V_{SEL_{2,1,0}} = 110$ (19.667 V), 18.5 V < V_{LNBx} < 21 V, TCTRLx = 0	-	30	40	mA
LNB Off Current	$I_{LNB(OFF)}$	$V_{IN} = 16$ V	-	-	10	μA

Continued on the next page...

ELECTRICAL CHARACTERISTICS ^[1] (continued) at $T_A = 25^\circ\text{C}$, $V_{IN} = 10$ to 16 V , • as noted^[2], unless noted otherwise

Characteristics	Symbol	Test Conditions	Min.	Typ.	Max.	Unit
GENERAL (continued)						
Ripple and Noise on LNBx Output ^[4]	$V_{rip,n(pp)}$	20 MHz BWL; reference circuit shown in Application Information section; contact Allegro for additional information on application circuit board design	–	15	–	mV _{PP}
VREG Voltage	V_{VREG}	$V_{IN} = 10\text{ V}$	4.97	5.25	5.53	V
ISET Voltage	V_{ISET}	$V_{IN} = 10\text{ V}$	3.4	3.5	3.6	V
TCAPx Voltage	V_{TCAPX}	$V_{IN} = 10\text{ V}$, $V_{OUT} = 13.667\text{ V}$	–	2.28	–	V
		$V_{IN} = 10\text{ V}$, $V_{OUT} = 19.000\text{ V}$	–	3.17	–	V
PROTECTION CIRCUITRY						
Output Overcurrent Limit ^[5]	$I_{OUT(MAX)}$	$R_{SET} = 100\text{ k}\Omega$	• 250	300	350	mA
		$R_{SET} = 37.4\text{ k}\Omega$	• 720	800	880	mA
Overcurrent Disable Time	t_{DIS}		–	45	–	ms
Boost MOSFET Current Limit	$I_{BOOST(MAX)}$	$R_{SET} = 100\text{ k}\Omega$	–	1680	–	mA
		$R_{SET} = 37.4\text{ k}\Omega$	–	4030	–	mA
VIN Undervoltage Lockout Threshold	V_{UVLO}	V_{IN} falling	8.05	8.35	8.65	V
VIN Turn On Threshold	$V_{IN(th)}$	V_{IN} rising	8.40	8.70	9.00	V
Undervoltage Hysteresis	$V_{UVLOHYS}$		–	350	–	mV
Thermal Shutdown Threshold ^[3]	T_J		–	165	–	°C
Thermal Shutdown Hysteresis ^[3]	ΔT_J		–	20	–	°C
Power Not Good (Low)	PNG_{LOSET}	With respect to V_{LNBx} setting; V_{LNBx} low, PNG set to 1	88	91	94	%
	$PNG_{LORESET}$	With respect to V_{LNBx} setting; V_{LNBx} low, PNG reset to 0	92	95	98	%
Power Not Good (Low) Hysteresis	PNG_{LOHYS}	With respect to V_{LNBx} setting	–	4	–	%
Power Not Good (High)	PNG_{HISET}	With respect to V_{LNBx} setting; V_{LNBx} high, PNG set to 1	106	109	112	%
	$PNG_{HIRESET}$	With respect to V_{LNBx} setting; V_{LNBx} high, PNG reset to 0	102	105	108	%
Power Not Good (High) Hysteresis	PNG_{HIHYS}	With respect to V_{LNBx} setting	–	4	–	%
TONE						
Amplitude	$V_{TONE(PP)}$	$I_{LNBx} = 0$ to 700 mA , $C_{LNBx} = 750\text{ nF}$	• 400	650	900	mV _{PP}
Frequency	f_{TONE}		• 20	22	24	kHz
Duty Cycle	DC_{TONE}		40	50	60	%
Rise Time	$t_{R(TONE)}$		5	10	15	μs
Fall Time	$t_{F(TONE)}$		5	10	15	μs

Continued on the next page...

ELECTRICAL CHARACTERISTICS ^[1] (continued) at $T_A = 25^\circ\text{C}$, $V_{IN} = 10$ to 16 V , • as noted ^[2], unless noted otherwise

Characteristics	Symbol	Test Conditions	Min.	Typ.	Max.	Unit
-tone detection						
Amplitude	$V_{TDX(PP)}$	TCTRLx = 1	400	650	900	mV _{PP}
	$V_{TDR(PP)}$	TCTRLx = 0; 22 kHz sine wave	250	650	900	mV _{PP}
Reject Amplitude, Low	$V_{TD(XMT)L}$	TCTRLx = 1	–	–	250	mV _{PP}
	$V_{TD(RCV)L}$	TCTRLx = 0; 22 kHz sine wave	–	–	100	mV _{PP}
Reject Amplitude, High	$V_{TD(XMT)H}$	TCTRLx = 1	–	–	1100	mV _{PP}
	$V_{TD(RCV)H}$	TCTRLx = 0; 22 kHz sine wave	–	–	1100	mV _{PP}
Frequency Capture	$f_{TD(RCV)}$	TCTRLx = 0; 650 mV _{PP} sine wave	17	22	27	kHz
	$f_{TD(XMT)}$	TCTRLx = 1; 650 mV _{PP} sine wave	20	22	24	kHz
Frequency Reject, Low	$f_{TD(RCV)L}$	TCTRLx = 0; 650 mV _{PP} sine wave	12	14	–	kHz
	$f_{TD(XMT)L}$	TCTRLx = 1; 650 mV _{PP} sine wave	15	17	–	kHz
Frequency Reject, High	$f_{TD(RCV)H}$	TCTRLx = 0; 650 mV _{PP} sine wave	–	34	37	kHz
	$f_{TD(XMT)H}$	TCTRLx = 1; 650 mV _{PP} sine wave	–	30	33	kHz
Detection Delay	t_{DET}	650 mV _{PP} , 22 kHz sine wave	–	1.5	3	cycle
TDIx Input Impedance	Z_{TDIx}		–	8.6	–	k Ω
tone control (TCTRL)						
Logic Input	V_H		2.0	–	–	V
	V_L		–	–	0.8	V
Input Leakage			–1	–	1	μA
I²C™-COMPATIBLE INTERFACE						
Logic Input (SDA,SCL) Low Level	$V_{SCL(L)}$		–	–	0.8	V
Logic Input (SDA,SCL) High Level	$V_{SCL(H)}$		2.0	–	–	V
Logic Input Hysteresis	$V_{I2CIHYS}$		–	150	–	mV
Logic Input Current	I_{I2CI}	$V_{I2CI} = 0$ to 5 V	–1	< \pm 1.0	1	μA
Logic Output Voltage SDA and IRQ	$V_{OUT(L)}$	$I_{LOAD} = 3\text{ mA}$	–	–	0.4	V
Logic Output Leakage SDA and IRQ	V_{LKG}	$V_{OUT} = 0$ to 5 V	–	–	10	μA
SCL Clock Frequency	f_{CLK}		–	–	400	kHz
I²C™ ADDRESS SETTING						
ADD Voltage for Address 0001,000	Address1		0	–	0.7	V
ADD Voltage for Address 0001,001	Address2		1.3	–	1.7	V
ADD Voltage for Address 0001,010	Address3		2.3	–	2.7	V
ADD Voltage for Address 0001,011	Address4		3.3	–	5.0	V

[1] Operation at 16 V may be limited by power loss in the linear regulator.

[2] Indicates specifications guaranteed from $0 \leq T_J \leq 125^\circ\text{C}_{MIN}$.

[3] Guaranteed by worst case process simulations and system characterization. Not production tested.

[4] LNBx output ripple and noise are dependent on component selection and PCB layout. Refer to the Application Schematic and PCB layout recommendations. Not production tested.

[5] Current from the LNBx output may be limited by the choice of Boost components.

FUNCTIONAL DESCRIPTION

Protection

The A8299 has a wide range of protection features and fault diagnostics which are detailed in the Status Register section.

Boost Converter/Linear Regulator

The A8299 solution contains a tracking current-mode boost converter and linear regulator. The boost converter tracks the requested LNBx voltage to within 800 mV, to minimize power dissipation. Under conditions where the input voltage, V_{BOOSTx} , is greater than the output voltage, V_{LNBx} , the linear regulator must drop the differential voltage. When operating in these conditions, care must be taken to ensure that the safe operating temperature range of the A8299 is not exceeded.

The boost converter operates at 352 kHz typical: 16 times the internal 22 kHz tone frequency. All the loop compensation, current sensing, and slope compensation functions are provided internally.

The A8299 has internal pulse-by-pulse current limiting on the boost converter and DC current limiting on the LNBx output to protect the IC against short circuits. When the LNBx output is shorted, the LNBx output current is limited, and if the overcurrent condition lasts for more than 45 ms, the LNBx output will be disabled. If this occurs, the A8299 channel x must be reenabled for normal operation. The system should provide sufficient time between successive restarts to limit internal power dissipation; 1 s to 2 s is recommended.

At extremely light loads, the boost converter operates in a pulse-skipping mode. Pulse skipping occurs when the BOOSTx voltage rises to approximately 450 mV above the BOOSTx target output voltage. Pulse skipping stops when the BOOSTx voltage drops 200 mV below the pulse skipping level.

In the case that two or more set top box LNBx outputs are connected together by the customer (e.g., with a splitter), it is possible that one output could be programmed at a higher voltage than the other. This would cause a voltage on one output that is higher than its programmed voltage (e.g., 19 V on the output of a 13 V programmed voltage). The output with the highest voltage will effectively turn off the other outputs. As soon as this voltage is reduced below the value of the other outputs, the A8299 output will auto-recover to their programmed levels.

Charge Pump. Generates a supply voltage above the internal tracking regulator output to drive the linear regulator control.

LNB and BOOST Current Limits. The LNBx output current limit, $I_{\text{OUT(MAX)}}$ can be set by connecting a resistor (R_{SET}) from the ISET pin to GND as shown in the applications schematic. The LNBx current limit can be set from 300 to 800 mA, corresponding to an R_{SET} value of 100 to 37.4 k Ω , respectively. If the LNBx current limit is exceeded for more than the Overcurrent Disable Time (t_{DIS}) then the LNBx output will be disabled and the OCPx bit set, as shown in figure 1. The LNBx output current limit can be set as high as 950 mA ($R_{\text{SET}} = 31.6$ k Ω) but care should be taken not to exceed the thermal limit of the package or thermal shutdown (TSD) will occur. The typical LNBx output current limit can be set according to the following equation:

$$I_{\text{OUT(MAX)}} = 29,925 / R_{\text{SET}} ,$$

where $I_{\text{OUT(MAX)}}$ is in mA and R_{SET} is in k Ω . If the voltage at the ISET pin is 0 V (that is, shorted to GND), $I_{\text{OUT(MAX)}}$ will be clamped to a moderately high value (approximately 1.5 A). Care should be taken to ensure that ISET is not inadvertently grounded. If no resistor is connected to the ISET pin (that is, if ISET is open-circuit), $I_{\text{OUT(MAX)}}$ will be set to approximately 0 A and the A8299 will not support any load (OCP will occur prematurely).

The BOOSTx pulse-by-pulse current limit, $I_{\text{BOOST(MAX)}}$, is automatically scaled along with the LNBx output current limit. The typical BOOSTx current limit is set according to the following equation:

$$I_{\text{BOOST(MAX)}} = 4.7 \times I_{\text{OUT(MAX)}} + 270 \text{ mA} ,$$

where both $I_{\text{BOOST(MAX)}}$ and $I_{\text{OUT(MAX)}}$ are in mA.

Automatically scaling the BOOSTx current limit allows the designer to choose the lowest possible saturation current of the boost inductor, reducing its physical size and PCB area, thus minimizing cost.

Slew Rate Control. During either start-up, or when the output voltage at the LNBx pin is transitioning, the output voltage rise and fall times can be set by the value of the capacitor connected from the TCAPx pin to GND (CTCAPx in the Applications Schematic). Note that during start-up, the BOOSTx pin is pre-charged

to the input voltage minus a diode voltage drop. As a result, the slow rate control for the BOOSTx pin occurs from this voltage.

The value of CTCAPx can be calculated using the following formula:

$$C_{TCAPx} = (I_{TCAPx} \times 6) / SR ,$$

where SR is the required slew rate of the LNBx output voltage, in V/s, and I_{TCAPx} is the TCAPx pin current specified in the Electrical Characteristics table. The recommended value for CTCAPx, 100 nF, should provide satisfactory operation for most applications.

The minimum value of CTCAPx is 10 nF. There is no theoretical maximum value of CTCAPx however too large a value will probably cause the voltage transition specification to be exceeded.

Tone generation is unaffected by the value of CTCAPx.

Pull-Down Rate Control. In applications that have to operate at very light loads and that require large load capacitances (in the order of tens to hundreds of microfarads), the output linear stage provides approximately 45 mA of pull-down capability. This ensures that the LNBx output voltage is ramped from 18 to 13 V

in a reasonable amount of time. When the tone is on (TCTRLx = 1), the output linear stage must increase its pull-down capability to approximately 100 mA. This ensures that the tone signal meets all specifications, even with no load on the LNBx output.

ODT (Overcurrent Disable Time)

If the LNBx output current exceeds the set output current, for more than 45 ms, then the LNBx output will be disabled and the OCP bit will be set. See figure 1.

Short Circuit Handling

If the LNBx output is shorted to ground, the LNBx output current will be clamped to $I_{OUT(MAX)}$. If the short circuit condition lasts for more than 45 ms, the LNBx output will be disabled and the OCPx bit will be set.

Auto-Restart

After a short circuit condition occurs, the host controller should periodically reenable the A8299 to check if the short circuit has been removed. Consecutive startup attempts should allow 1 s to 2 s of delay between restarts.

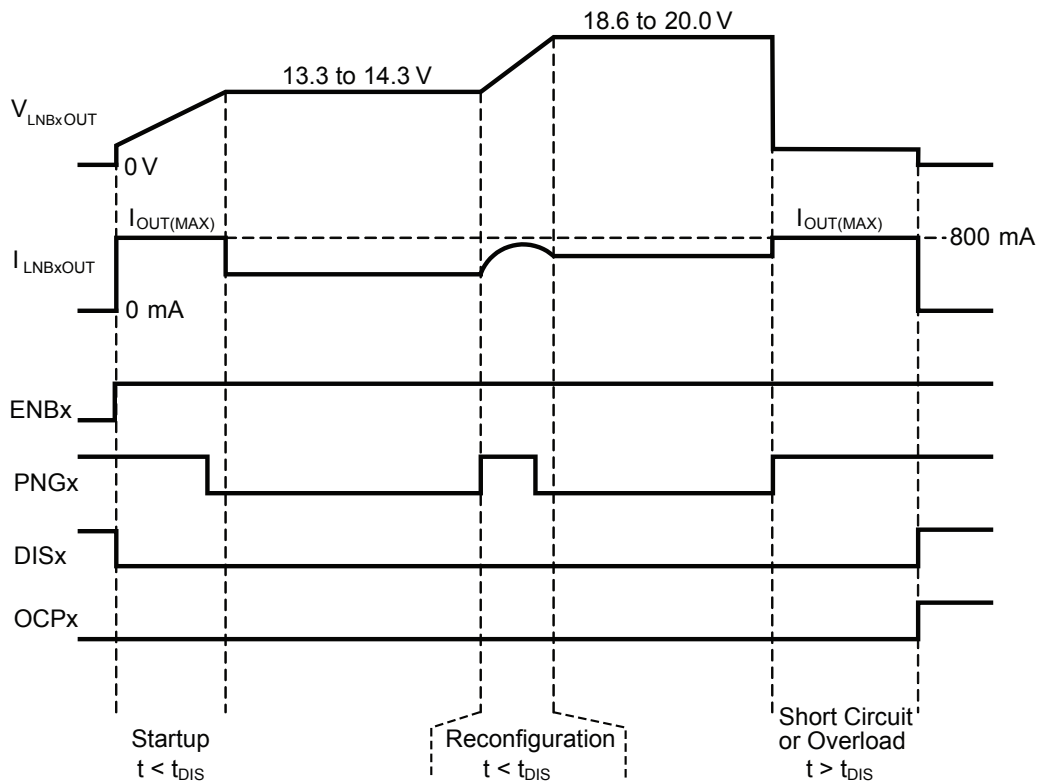

Figure 1. Startup, reconfiguration, and short circuit operation using $R_{SET} = 37.4 \text{ k}\Omega$, and a capacitive load

In-Rush Current

At start-up or during an LNBx reconfiguration event, a transient surge current above the normal DC operating level can be provided by the A8299. This current increase can be as high as the set output current, for as long as required, up to a maximum of 45 ms.

Tone Generation

A 22 kHz tone is generated internally, and can be controlled on and off via the TCTRLx pin as shown in figure 2. Note this tone can be generated under no-load conditions, and does not require the use of an external DiSEqC filter.

Tone Detection

A 22 kHz tone detector is provided in the A8299. The detector extracts the 22 kHz signal from the AC-coupled TDix pin. Also, when a tone is present, the TDETx bit in the Status register is set high and can be seen via the I²C interface. The tone detection delay is typically shorter than 1.5 cycles.

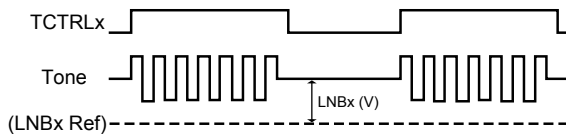

Figure 2. Internal tone, gated by TCTRLx pin

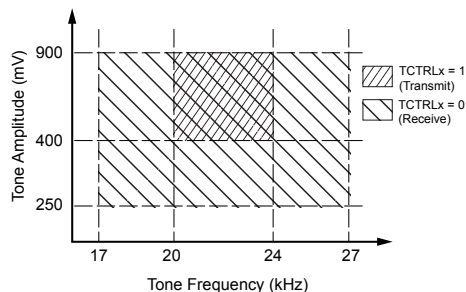

Figure 3a. Accept Ranges of Tone Detection feature

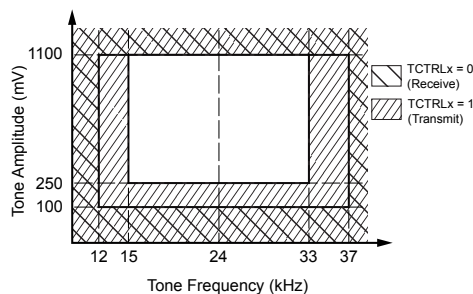

Figure 3b. Reject Ranges of Tone Detection feature

The tone detector dynamically adjusts its amplitude and frequency thresholds depending on whether the A8299 is transmitting or receiving a tone signal. If TCTRLx is a logic high, the A8299 is transmitting and the tone detect amplitude threshold is relatively high and the acceptable frequency range is tight. This guarantees a high quality tone signal is always generated by the A8299. On the other hand, if TCTRLx is a logic low, the A8299 is receiving and the tone detect amplitude threshold is reduced and the acceptable frequency range is increased slightly. This guarantees the A8299 has maximum sensitivity to remotely generated tone signals that may be degraded by long lengths of coaxial cable. The Electrical Characteristics table of this datasheet documents the guaranteed specifications of the tone detector and how they are adjusted by TCTRLx. To help in the understanding, typical tone detector operation is shown graphically in figures 3a and 3b. The shaded areas in figure 3a indicate the accept range of the detector when TCTRLx is a logic high (transmit) and a logic low (receive). The shaded areas in figure 3b indicate the reject range of the detector when TCTRLx is a logic high (transmit) and a logic low (receive).

RESET Input

The A8299 includes a $\overline{\text{RESET}}$ input that instantly turns off the LNBx output and resets the internal Control register to its default (power-on) state. When $\overline{\text{RESET}} = 0$, the A8299 will draw $I_{\text{IN(OFF)}}$ from the input supply (nominally 5 mA). If AC power is unexpectedly removed from the set top box, the $\overline{\text{RESET}}$ input allows the host microcontroller to instantly shut down the A8299 without using the I²C™ interface. In this situation, the $\overline{\text{RESET}}$ input conserves power, saves time, frees up the I²C™ bus, and allows the microcontroller to perform other housekeeping functions before the set top box power rails decay to zero. The $\overline{\text{RESET}}$ input is internally pulled-up by a high value resistance, so, if the $\overline{\text{RESET}}$ input is not use, it may be left floating.

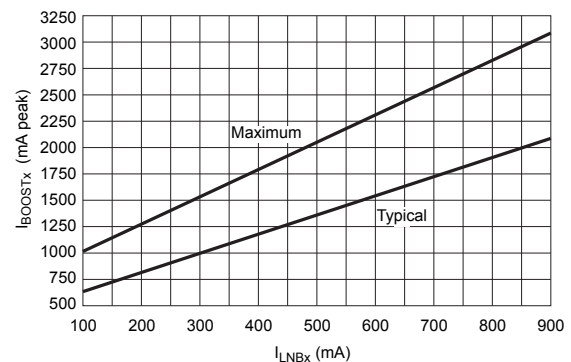

Figure 4. Boost inductor peak current versus I_{LNBx} for the A8299

COMPONENT SELECTION

BOOST INDUCTOR

The A8299 is designed to operate with a boost inductor value of 15 μH +30%/–40% with a DCR less than 75 m Ω . The error amplifier loop compensation, current sense gain, and PWM slope compensation were chosen for this value of inductor. The boost inductor must be able to support the peak currents required to maintain the maximum LNBx output current without saturating. Figure 4 can be used to determine the peak current in the inductor given the LNBx load current. The typical curve uses $V_{\text{IN}} = 12\text{ V}$, $V_{\text{OUT}} = 19\text{ V}$, $L = 15\ \mu\text{H}$, and $f = 352\text{ kHz}$, while the maximum curve assumes $V_{\text{IN}} = 9\text{ V}$, $V_{\text{OUT}} = 20\text{ V}$, $L = 12\ \mu\text{H}$, and $f = 282\text{ kHz}$.

The system will have reduced gain and phase margins, if the boost inductor is higher than 22 μH . Figure 5 shows a Bode plot of the boost loop with $3 \times 10\ \mu\text{F}$ of boost capacitance and 33, 22, 18, 15, and 10 μH of boost inductance. Although this plot assumes many of the system variables are worst case (10.8 V_{IN} , 20 V_{OUT} , +2% DAC tolerance, 1V of ΔV_{REG} , 1.1 A load, and 320 kHz), these conditions could certainly occur in an application. This plot shows that, as the boost inductance increases, the 0 dB crossover frequency remains relatively constant but the phase and gain margins are reduced. With 22 μH , the phase margin is 32° and with 33 μH the phase margin is only 10°.

BOOST CAPACITORS

The A8299 is designed to operate with two or three, high-quality ceramic capacitors on the boost node. Allegro recommends

capacitors that are rated at least 35 V, $\pm 10\%$, X7R, 1210 size. Physically smaller capacitors, like 0603 and 0805, with lower temperature ratings, as X5R and Z5U, should be avoided. Figure 6 can be used to determine the necessary rms current rating of the boost capacitor given the LNB load current. The typical curve uses $V_{\text{IN}} = 12\text{ V}$, $V_{\text{OUT}} = 19\text{ V}$, $L = 15\ \mu\text{H}$, and $f = 352\text{ kHz}$ while the maximum curve assumes $V_{\text{IN}} = 9\text{ V}$, $V_{\text{OUT}} = 20\text{ V}$, $L = 12\ \mu\text{H}$, and $f = 282\text{ kHz}$.

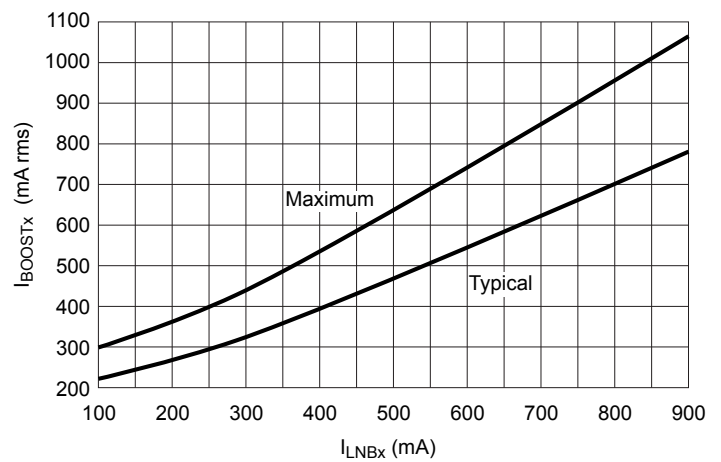

Figure 6. Boost capacitor rms current versus I_{LNBx} for the A8299

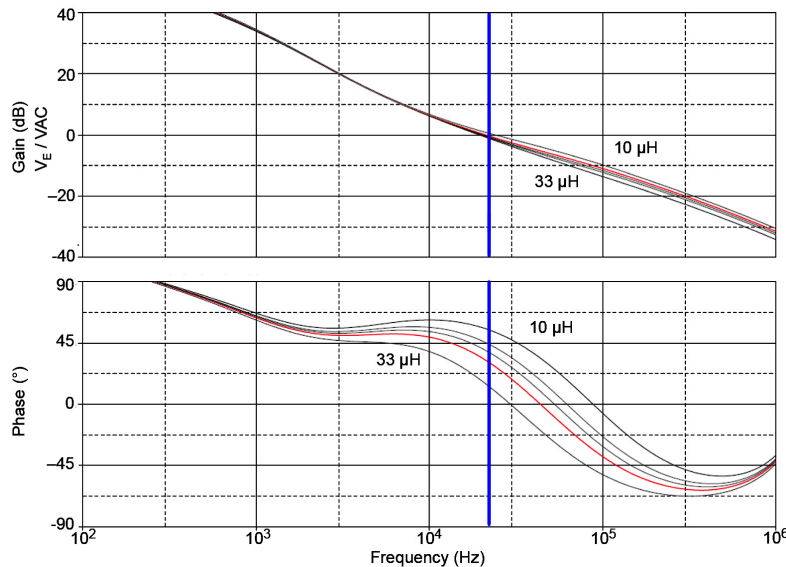

Figure 5. Gain and Phase Margin of the boost loop at various inductance levels

The nominal boost capacitance should total 18.8 to 30 μF . Allegro recommends either four 4.7 μF or three 10 μF capacitors, with the characteristics shown in table 1. If tolerance, temperature, and DC bias effects are considered, the capacitance must total at least 13 μF . The DC bias effect is very significant on ceramic capacitors with lower voltage ratings, smaller packages, or wider temperature characteristics. For example, a 10 μF , 25 V, 1206, X5R capacitor can lose 85% of its value at 20 VDC bias. If the total boost capacitance becomes less than 12 μF , the converter will have reduced gain and phase margins. If the total boost capacitance becomes less than 7.5 μF , then the converter will very likely be unstable.

Figure 7 shows a Bode plot of the boost loop with 15 μH of boost inductance and 20, 15, 10, 7.5, and 5 μF of boost capacitance.

Although this plot assumes many of the system variables are worst case (10.8 V_{IN} , 20 V_{OUT} , +2% DAC tolerance, 1 V of ΔV_{REG} , 1.1 A load, and 320 kHz), these conditions could certainly occur in an application. This plot shows that, as the boost capacitance decreases, the 0 dB crossover frequency increases and the phase and gain margins are reduced. At 7.5 μF the phase margin is only 6° and at 5 μF this system is unstable.

Two possible ceramic based capacitor solutions have been presented. Other capacitor combinations are certainly possible, such as a very low ESR electrolytic capacitor in parallel with several microfarads of ceramic capacitance. However, there are two critical requirements that must be satisfied: 1) the zero formed by the electrolytic capacitor and its ESR should be at least 1 decade higher than the 0 dB crossover of the boost loop (typically around

Table 1. Recommended Boost Capacitor Characteristics

Quantity of Capacitors	Value (μF)	Tolerance (%)	Rating (V)	Temperature Coefficient of Capacitance	Size	Total Capacitance at -10% and 20 VDC Bias (μF)
4	4.7	± 10	50	X7R	1210	14.0
3	10	± 10	35	X7R	1210	18.6

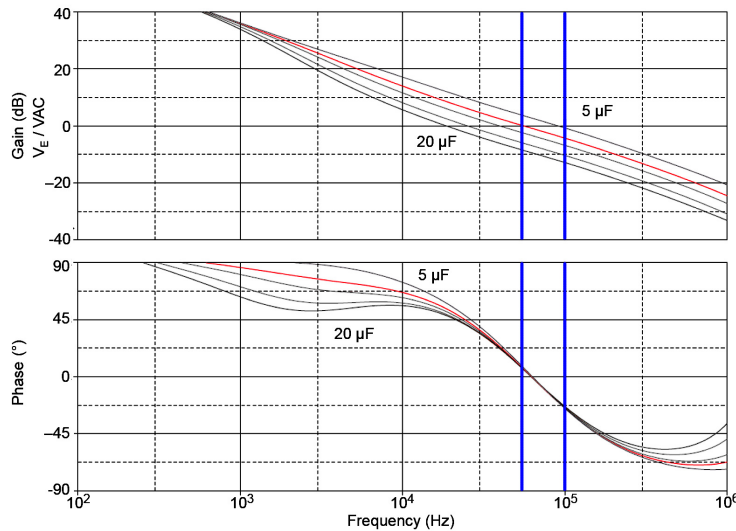

Figure 7. Gain and Phase Margin of the boost loop at various capacitance values

25 kHz), and 2) the ceramic capacitors must eliminate the high frequency switching spikes/edges in the boost voltage, or the LNBx output noise will be too high.

BOOST FILTERING AND LNB NOISE

The LNBx output noise depends on the amount of high-frequency noise at the BOOSTx pin. To minimize the high-frequency noise at the BOOSTx pin, the ceramic capacitors should be placed as close as possible to the BOOSTx pin.

SURGE COMPONENTS

The circuit shown in schematic 1 includes external diodes for surge protection. The Applications Information section includes D2, D3, D3a, D3b, D4 and D5 component recommendations in tables 6 and 7. This configuration and these components have successfully passed surge tests up to ± 1000 V/500 A, with a 1.2/50 μ s – 8/20 μ s combination wave.

Recently, set-top-box suppliers have increased their surge specifications to require surge to failure of the TVS or ± 4000 V, whichever occurs first. These increased surge voltages produce significantly more current in the both the external circuitry and the A8299. Allegro surge testing has shown that the SMDJ20A and LNBTVS6-221 usually fail at approximately 43 V, so all the LNBR output components (ceramic capacitors, diodes, etc.) should support at least 50 V.

To protect at these higher voltage/current levels three modifications must be made:

- For increased positive surge, the shunting diode from the LNBx pin to the BOOSTx pin (D3x, 3 A/40 V) will no longer be able to protect the body diode of the output stage. This diode must be increased to a 3 A/50 V device and be located so that it is in series with the BOOSTx pin as shown in schematics 3 and 4. In this position D3x will block surge current to the majority of the boost capacitance, but the 1 μ F ceramic capacitor will still filter the high frequency switching noise.
- For increased negative surge, the relatively small clamping diode (D2 and D4) from LNBx to ground will no longer be sufficient. This diode must be increased from a 1 A/40 V, SOD123 to a 3 A/50 V, SMA device.
- For a DiSEqC 1.0 application, a 0.47 Ω /1%/0.25 W series resistor also must be added as shown in the application drawings. The 0.47 Ω resistor could be reduced if there is enough equivalent resistance in any series output components such as jumpers, inductors, or PCB traces.

Every application will have its own surge requirements and the surge solution can be changed. However, Allegro strongly recommends incorporating a form of surge protection to prevent any pin of the A8299 from exceeding its Absolute Maximum voltage ratings shown in this datasheet.

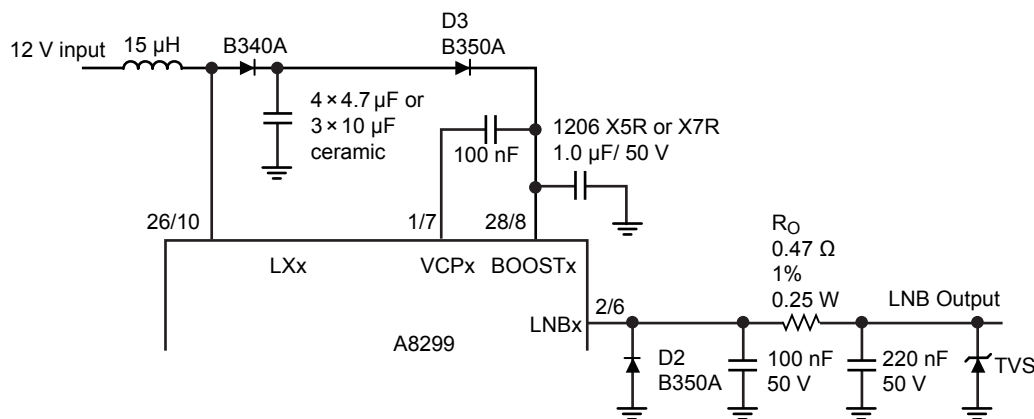

Figure 8. Application of surge protection upgrades

I²C™-Compatible Interface

The I²C™ interface is used to access the internal Control and Status registers of the A8299. This is a serial interface that uses two lines, serial clock (SCL) and serial data (SDA), connected to a positive supply voltage via a current source or a pull-up resistor. Data is exchanged between a microcontroller (master) and the A8299 (slave). The master always generates the SCL signal. Either the master or the slave can generate the SDA signal. The SDA and SCL lines from the A8299 are open-drain signals so multiple devices may be connected to the I²C™ bus. When the bus is free, both the SDA and the SCL lines are high.

SDA and SCL Signals. SDA can only be changed while SCL is low. SDA must be stable while SCL is high. However, an exception is made when the I²C™ Start or Stop condition is encountered. See the I²C™ Communication section for further details.

Acknowledge (AK) Bit. The Acknowledge (AK) bit indicates a good transmission and can be used two ways. First, if the slave has successfully received eight bits of either an address or control data, it will pull the SDA line low (AK=0) for the ninth SCL pulse to signal good transmission to the master. Second, if the master has successfully received eight bits of status data from the A8299, it will pull the SDA line low for the ninth SCL pulse to signal good transmission to the slave. The receiver (either the master or the slave) should set the AK bit high (AK=1 or NAK) for the ninth SCL pulse if eight bits of data are not received successfully.

AK Bit During a Write Sequence. When the master sends control data (writes) to the A8299 there are three instances where AK bits are toggled by the A8299. First, the A8299 uses the AK bit to indicate reception of a valid seven-bit chip address plus a read/write bit (R/W=0 for write). Second, the A8299 uses the AK bit to indicate reception of a valid eight-bit Control register address. Third, the A8299 uses the AK bit to indicate reception of eight bits of control data. This protocol is shown in figure 9(A).

AK Bit During a Read Sequence. When the master reads status data from the A8299 there are four instances where AK bits are sent—three sent by the A8299 and one sent by the master. First, the A8299 uses the AK bit to indicate reception of a valid seven-bit chip address plus a read/write bit (R/W=0 for write). Second, the A8299 uses the AK bit to indicate reception of a valid eight-bit status register address. Third, the A8299 uses the AK bit to indicate reception of a valid seven-bit chip address plus a read/write bit (R/W=1 for read). Finally, the master uses the AK bit to indicate receiving eight bits of status data from the A8299. This protocol is shown in figure 9(B).

I²C™ Communications

I²C™ Start and Stop Conditions. The I²C™ Start condition is defined by a negative edge on the SDA line while SCL is high. Conversely, the Stop condition is defined by a positive edge on the SDA line while SCL is high. The Start and Stop conditions are shown in figure 9. It is possible for the Start or Stop condition to occur at any time during a data transfer. If either a Start or

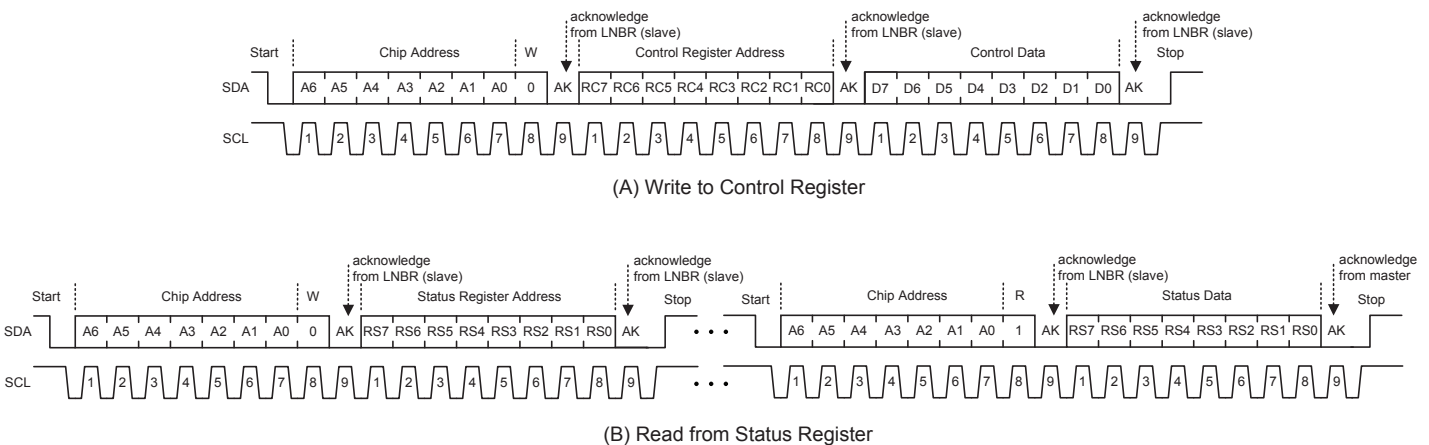

Figure 9. I²C™ Interface Read and Write Sequences. (A) for the I²C™ Write cycle and (B) for the I²C™ Read cycle

Stop condition is encountered during a data transfer, the A8299 will respond by resetting the data transfer sequence.

I²C™ Write Cycle Description. Writing to the A8299 Control register requires transmission of a total of 27 bits—three 8-bit bytes of data plus an Acknowledge bit after each byte. Writing to the A8299 Control register is shown in figure 9(A). Writing to the A8299 Control register requires a chip address with R/W=0, a Control register address, and the control data, as follows:

- The Chip Address cycle consists of a total of nine bits—seven bits of chip address (A6 to A0) plus one read/write bit (R/W=0) to indicate a write from the master followed by an Acknowledge bit (AK=0 for reception of a valid chip address) from the slave. The chip address must be transmitted MSB (A6) first. The first five bits of the A8299 chip address (A6 to A2) are fixed as 00010. The remaining two bits (A1 and A0) are used to select one of four possible A8299 chip addresses. The DC voltage on the ADD pin programs the chip address. See the Electrical Characteristics table for the ADD pin voltages and the corresponding chip addresses.
- The Control Register Address cycle consists of a total of nine bits—eight bits of control register address (RC7 to RC0) from the master followed by an Acknowledge bit from the slave. The Control register address must be transmitted MSB (RC7) first. The A8299 only has one Control register so the Control register address is fixed as 00000000.
- The Control Data cycle consists of a total of nine bits—eight bits of control data (D7 to D0) from the master followed by an Acknowledge bit from the slave. The control data must be transmitted MSB first (D7). The Control register bits are identified in the Control Register section of this datasheet.

I²C™ Read Cycle Description. Reading from the A8299 Status register requires transmission of a total of 36 bits—four 8-bit bytes of data plus an Acknowledge bit after each byte. Reading the A8299 Status register requires a chip address with R/W=0, a Status register address, an I²C™ Stop condition, an I²C™ Start condition, a repeated chip address with R/W = 1, and finally the status data from the A8299. Reading from the A8299 Status regis-

ter is shown in figure 9(B).

- This 9-bit Chip Address cycle is identical to the Chip Address cycle previously described for the Write Control register sequence. It consists of A6 to A0, plus one read/write bit (R/W=0) from the master, followed by an Acknowledge bit from the slave, and finally an I²C™ Stop condition.
- The Status Register Address cycle consists of a total of nine bits—eight bits of Status register address (RS7 to RS0) from the master, followed by an Acknowledge bit from the slave. The Status register address must be transmitted MSB (RS7) first. The A8299 has two Status registers so the Status register address is either 00000000 or 00000001.
- The Repeated Chip Address cycle begins with an I²C™ Start condition followed by a 9-bit cycle identical to the Chip Address cycle previously described for the Write Control Register sequence. It consists of A6 to A0, plus one read/write bit (R/W=1) from the master, followed by an Acknowledge bit from the slave.
- The Status Data cycle consists of a total of nine bits—eight bits of status data (RD7 to RD0) from the slave, followed by an Acknowledge bit from the master. The status data is transmitted MSB (RD7) first. The Status register bits are identified in the Status Register section of this data sheet.

Interrupt (IRQ) and Fault Clearing

The A8299 provides an interrupt request pin (IRQ), which is an open-drain, active low output. This output may be connected to a common IRQ line with a suitable external pull-up resistor and can be used with other I²C™ compatible devices to request attention from the master controller.

The IRQ output becomes active (logic low) when the A8299 recognizes a fault condition. The fault conditions that will force IRQ active include undervoltage lockout (UVLO), overcurrent protection (OCPx), and thermal shutdown (TSD). The UVLO, OCPx, and TSD faults are latched in the Status register and will not be unlatched until the A8299 Status register is successfully transmitted to the master controller (an AK bit must be received

from the master). See the description in the Status Register section and figure 10 for further details.

When the master device receives an interrupt, it should address all slaves connected to the interrupt line in sequence and read the status register of each to determine which device is requesting attention. As shown in figure 10, the A8299 latches all conditions in the Status register and sets the IRQ to logic low when

a UVLO, OCPx, or TSD event occurs. The IRQ bit is reset to logic high and the Status register is unlatched when the master acknowledges the status data from the A8299 (an AK bit must be received from the master).

The disable (DISx) and Power Not Good (PNGx) conditions do not cause an interrupt and are not latched in the Status register.

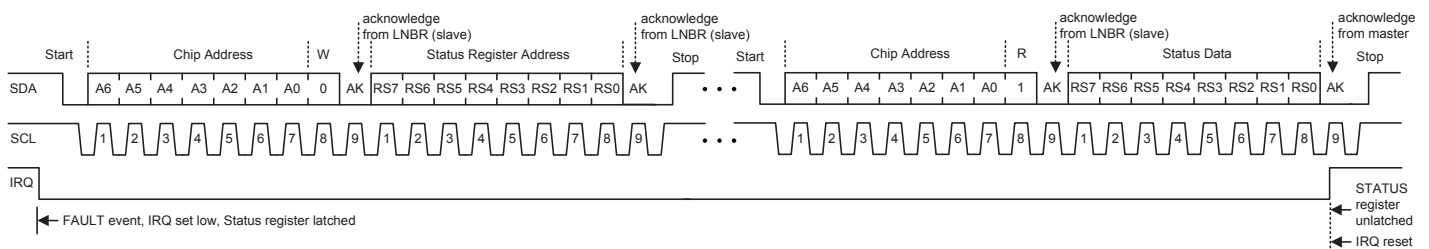

Figure 10. Fault, IRQ, and Status Register Timing. When a UVLO, OCPx, or TSD event occurs, the IRQ bit is set low and the Status register is latched. The IRQ bit is reset to high when the A8299 acknowledges it is being read. The Status register is unlatched when the master acknowledges the status data from the A8299.

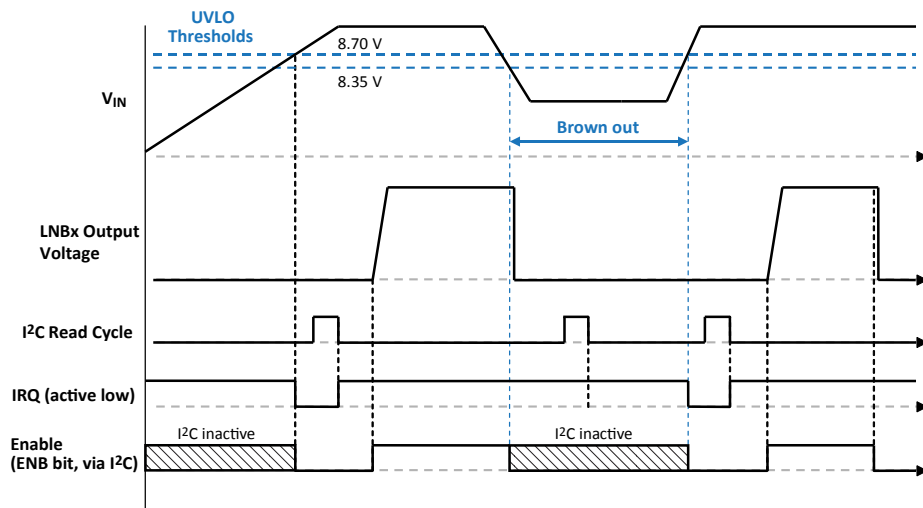

Figure 11. IRQ and Fault Clearing in Response to Undervoltage at V_{IN} (UVLO). At power-up, while V_{IN} is below 8.70 V (typ), the A8299 is disabled and the I²C port is inactive. After V_{IN} rises above 8.70 V (typ), the I²C port becomes active and the IRQ pin is pulled low. An I²C Read is required to report and clear the UVLO fault and set the IRQ pin to a logic high before the A8299 can be enabled. If a brown-out occurs, such that V_{IN} drops below 8.35 V (typ), the A8299 will be disabled and the I²C port will become inactive (note that the IRQ pin will remain high during this time because the A8299 is disabled). After V_{IN} rises above 8.70 V (typ) the I²C port reactivates and the IRQ pin is pulled low to report that a brown-out had occurred. An I²C Read is required to report and clear the UVLO fault before the A8299 can be re-enabled.

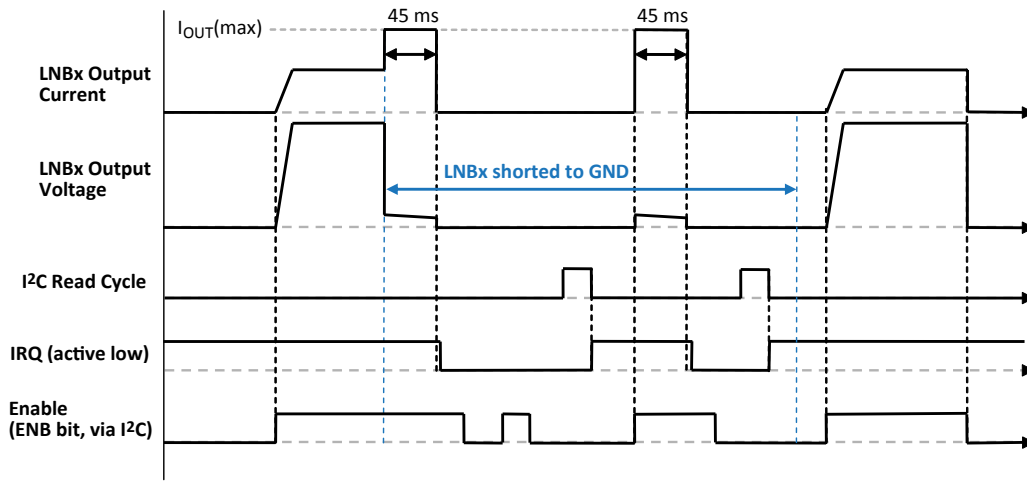

Figure 12. IRQ and Fault Clearing in Response to Overcurrent (OCP). If the LNBx output is grounded for more than 45 ms, the LNBx output will be shut off, an overcurrent fault (OCP) will be latched in the Status Register, and the IRQ pin will transition low. After an OCP fault, the LNBx output does not respond to the Enable (ENB) bit until an I²C Read cycle is executed to report and clear the OCP fault. After a successful I²C Read, the IRQ pin transitions high and the A8299 can be re-enabled, provided the LNBx output is no longer grounded.

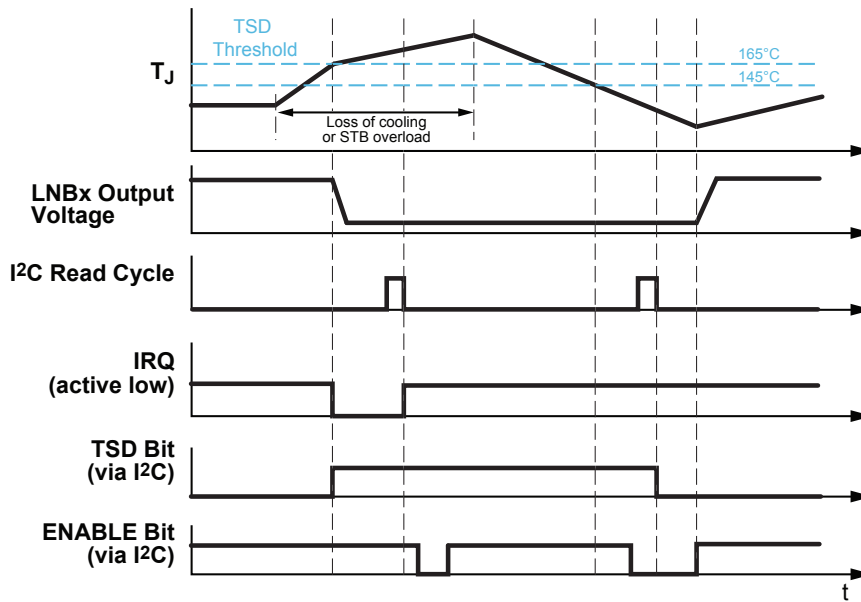
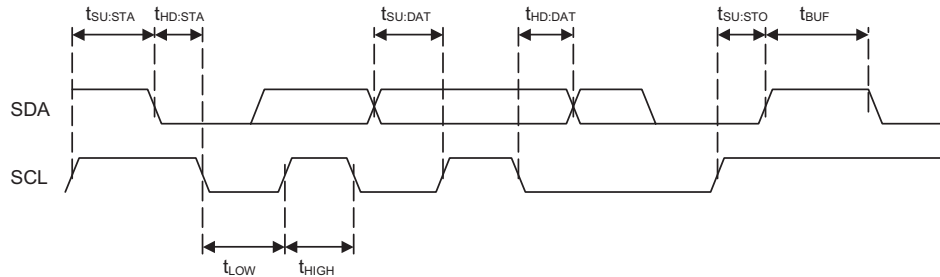

Figure 13. IRQ and Fault Clearing in Response to Thermal Shutdown (TSD). If the A8299 junction temperature rises above 165°C (typ), the LNBx output will be shut off, a thermal shutdown fault (TSD) will be latched in the Status Register, and the IRQ pin will transition low. After a TSD fault, the LNBx output does not respond to the Enable (ENB) bit until an I²C Read cycle is executed to report and clear the TSD fault. After a successful I²C Read, the IRQ pin transitions high and the A8299 can be re-enabled, provided the junction temperature is below 145°C (typ).

I²C™-Compatible Interface Timing DiagramI²C™-Compatible Timing Requirements

Characteristics	Symbol	Min.	Typ.	Max.	Unit
Bus Free Time Between Stop/Start	t_{BUF}	1.3	–	–	μ s
Hold Time Start Condition	$t_{HD:STA}$	0.6	–	–	μ s
Setup Time for Start Condition	$t_{SU:STA}$	0.6	–	–	μ s
SCL Low Time	t_{LOW}	1.3	–	–	μ s
SCL High Time	t_{HIGH}	0.6	–	–	μ s
Data Setup Time	$t_{SU:DAT}$	100	–	–	ns
Data Hold Time*	$t_{HD:DAT}$	0	–	900	ns
Setup Time for Stop Condition	$t_{SU:STO}$	0.6	–	–	μ s
Output Fall Time ($V_{fI2COut(H)}$ to $V_{fI2COut(L)}$)	$t_{fI2COut}$	–	–	250	ns

*For $t_{HD:DAT}(\text{min})$, the master device must provide a hold time of at least 300 ns for the SDA signal in order to bridge the undefined region of the SCL signal falling edge.

Control Register (I²C™-Compatible Write Register)

All main functions of the A8299 are controlled through the I²C™ compatible interface via the 8-bit Control register. Table 2 shows the functionality and bit definitions of the Control register. At power-up, the Control register is initialized to all 0s.

Table 2. Control Register Definition, Control (Write) Register Address <RC7:RC0> = 00000000

Bit	Name	Function	Description
0	VSEL0<1>	Output 1 voltage amplitude selection. See table 3 for available output voltage selections.	The available voltages provide levels for all the common standards plus the ability to add line compensation. VSEL0 is the LSB and VSEL2 is the MSB to the internal DAC.
1	VSEL1<1>		
2	VSEL2<1>		
3	ENB1	0: Disable LNB Output 1 1: Enable LNB Output 1	Turns LNB1 on or off.
4	VSEL0<2>	Output 2 voltage amplitude selection. See table 3 for available output voltage selections.	The available voltages provide levels for all the common standards plus the ability to add line compensation. VSEL0 is the LSB and VSEL2 is the MSB to the internal DAC.
5	VSEL1<2>		
6	VSEL2<2>		
7	ENB2	0: Disable LNB Output 2 1: Enable LNB Output 2	Turns LNB2 on or off.

Table 3. Output Voltage Selection

VSEL2x	VSEL1x	VSEL0x	LNBx (V)
0	0	0	13.333
0	0	1	13.667
0	1	0	14.000
0	1	1	14.333
1	0	0	18.667
1	0	1	19.000
1	1	0	19.667
1	1	1	20.000

Status Registers (I²C™-Compatible Read Register)

The main fault conditions: undervoltage lockout (UVLO), overcurrent (OCPx), and thermal shutdown (TSD) are all indicated by setting the relevant bits in the Status registers. In all fault cases, after the bit is set, it remains latched until the I²C™ master has successfully read the A8299, assuming the fault has been resolved.

The undervoltage lockout (UVLO) bit indicates either the input voltage at the VIN pin is too low or the A8299 internal supply voltage (VREG) is too low.

The Disable bit (DISx) indicates the status of the LNBx output. The DISx bit is set when either a fault occurs (UVLO, OCPx, TSD, or CPOKx) or when the LNBx output is turned off using the Enable bit (ENB) via the I²C™ interface. The DISx bit is

latched and is only reset when there are no faults and the A8299 output is turned back on using the Enable (ENB) bit via the I²C™ interface.

The Power Not Good (PNGx), Charge Pump OK (CPOKx), and Tone Detect (TDETx) bits are set based on the conditions sensed at the LNBx output, VCPx, and Tone Detect Input (TDIx) pins, respectively. These bits are not latched and, unlike the other fault bits, may become reset without an I²C™ read sequence. The PNGx, CPOKx, and TDETx bits are continuously updated.

There are three methods to detect when the Status registers change: responding to the interrupt request (IRQ) pin going low, continuously polling the Status registers via the I²C™ interface, or detecting a fault condition external to the A8299 and performing a diagnostic poll of the A8299. In any case, the master should read and re-read the Status registers until the status changes.

Table 4(a). Status Register, Status (Read) Register Address <RS7:RS0> = 00000000

Bit	Name	Function	Latched?	Reset Condition	Effect on IRQ Pin
0	DIS1	LNB1 output disabled	Yes	LNBx enabled and no faults	None
1	DIS2	LNB2 output disabled			
2	OCP1	LNB1 Overcurrent	Yes	I ² C™ read and fault removed	IRQ set low
3	OCP2	LNB2 Overcurrent			
4	PNG1	LNB1 Power Not Good	No	LNBx voltage within range	None
5	PNG2	LNB2 Power Not Good			
6	UVLO	V _{IN} or V _{REG} Undervoltage	Yes	I ² C™ read and fault removed	IRQ set low
7	TSD	Thermal Shutdown	Yes	I ² C™ read and fault removed	IRQ set low

Table 4(b). Status Register, Status (Read) Register Address <RS7:RS0> = 00000001

Bit	Name	Function	Latched?	Reset Condition	Effect on IRQ Pin
0	CPOK1	LNB1 Charge Pump OK	No	V _{VCPx} > V _{BOOSTx} + 5 V	None
1	CPOK2	LNB2 Charge Pump OK			
2	TDET1	LNB1 Tone Detect	No	Tone removed from LNB1 pin	None
3	TDET2	LNB2 Tone Detect	No	Tone removed from LNB2 pin	None
4	TRIMS	Trim bits locked	Yes	None	None
5	Unused	–	–	–	–
6	Unused	–	–	–	–
7	Unused	–	–	–	–

Table 5. Status Register Bit Descriptions

Bit	Name	Description
0	DISx	The DISx bit is set to 1 when the A8299 is disabled, (ENBx = 0) or there is a fault: UVLO, OCPx, CPOKx, or TSD.
1	CPOKx	The the CPOKx bit is set low, the internal charge pump is not operating correctly (VCPx). If the charge pump voltage is too low, the LNBx output is disabled and the DISx bit is set.
2	OCPx	The OCPx bit will be set to a 1 if the LNBx output current exceeds the overcurrent threshold ($I_{OUT(MAX)}$) for more than the overcurrent disable time (t_{DIS}). If the OCPx bit is set to 1, then the DISx bit is also set to 1.
3	TRIMS	Factory use only.
4	PNGx	The PNGx bit is set to 1 when the A8299 is enabled and the LNBx output voltage is either too low or too high (nominally $\pm 9\%$ from the LNBx DAC setting). Set to 0 when the A8299 is enabled and the LNBx voltage is within the acceptable range (nominally $\pm 5\%$ from the LNBx DAC setting).
5	TDETx	The TDETx bit is set to 1 if a tone is detected at the TDIx pin that is within the specified voltage and frequency ranges. If TCTRLx = 1, the tone is being transmitted by the A8299 and the tone detect low threshold is determined by $V_{TD(XMT)L}$. If TCTRLx = 0, it is assumed the tone is being received from an external source and the tone detect low threshold is determined by $V_{TD(RCV)L}$.
6	TSD	The TSD bit is set to 1 if the A8299 has detected an overtemperature condition. If the TSD bit is set to 1, then the DISx bit is also set to 1.
7	UVLO	The UVLO bit is set to 1 if either the voltage at the VIN pin or the voltage at the VREG pin is too low. If the UVLO bit is set to 1, then the DISx bit is also set to 1.

APPLICATION INFORMATION

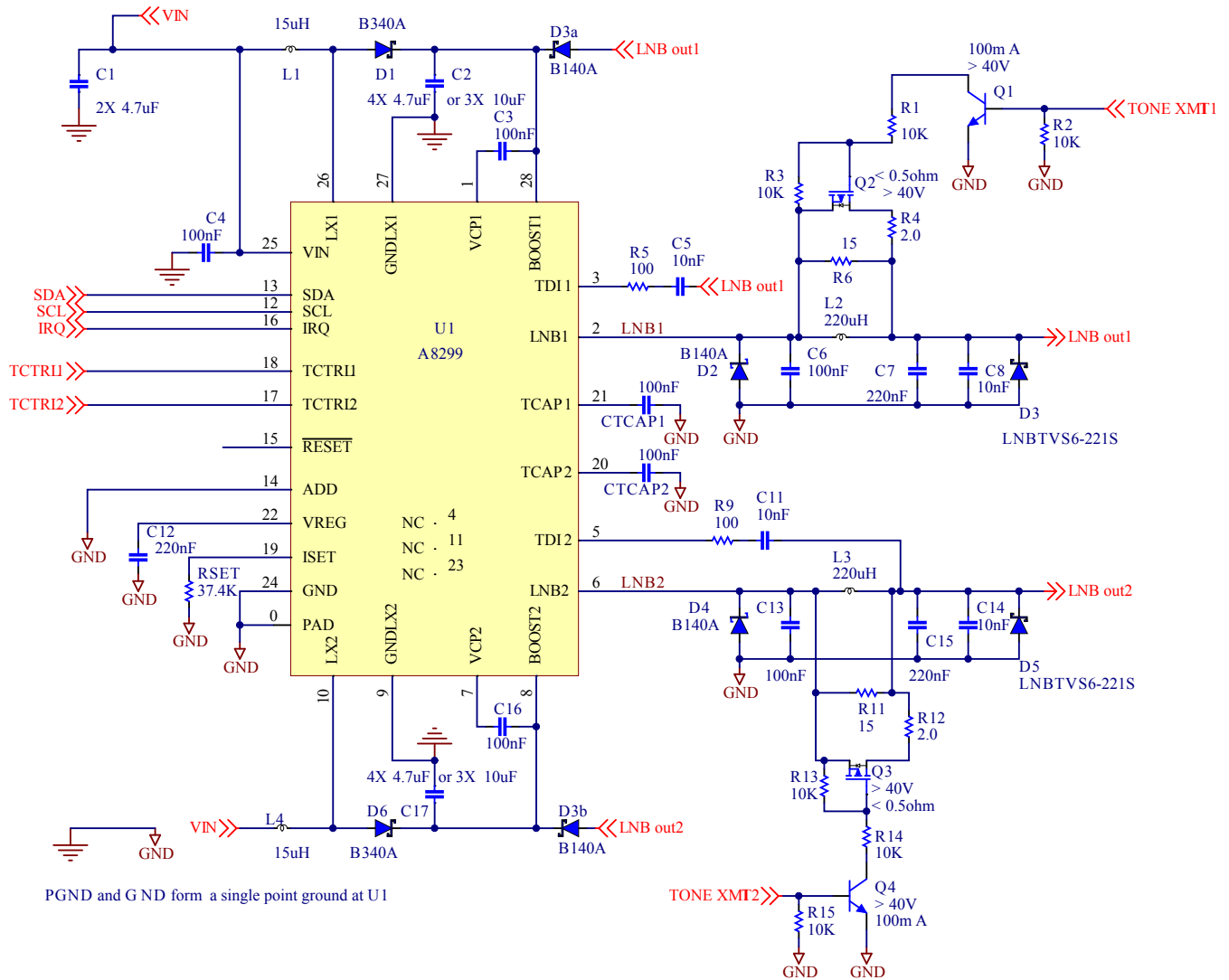

See table 6 for bill of materials

Schematic 1. DiSEqC 2.0 Applications, 12 V_{IN} ±10%, 700 mA I_{OUT}, surge of ±1000 V, 2 Ω, 1.2/50 μs – 8/20 μs combination wave

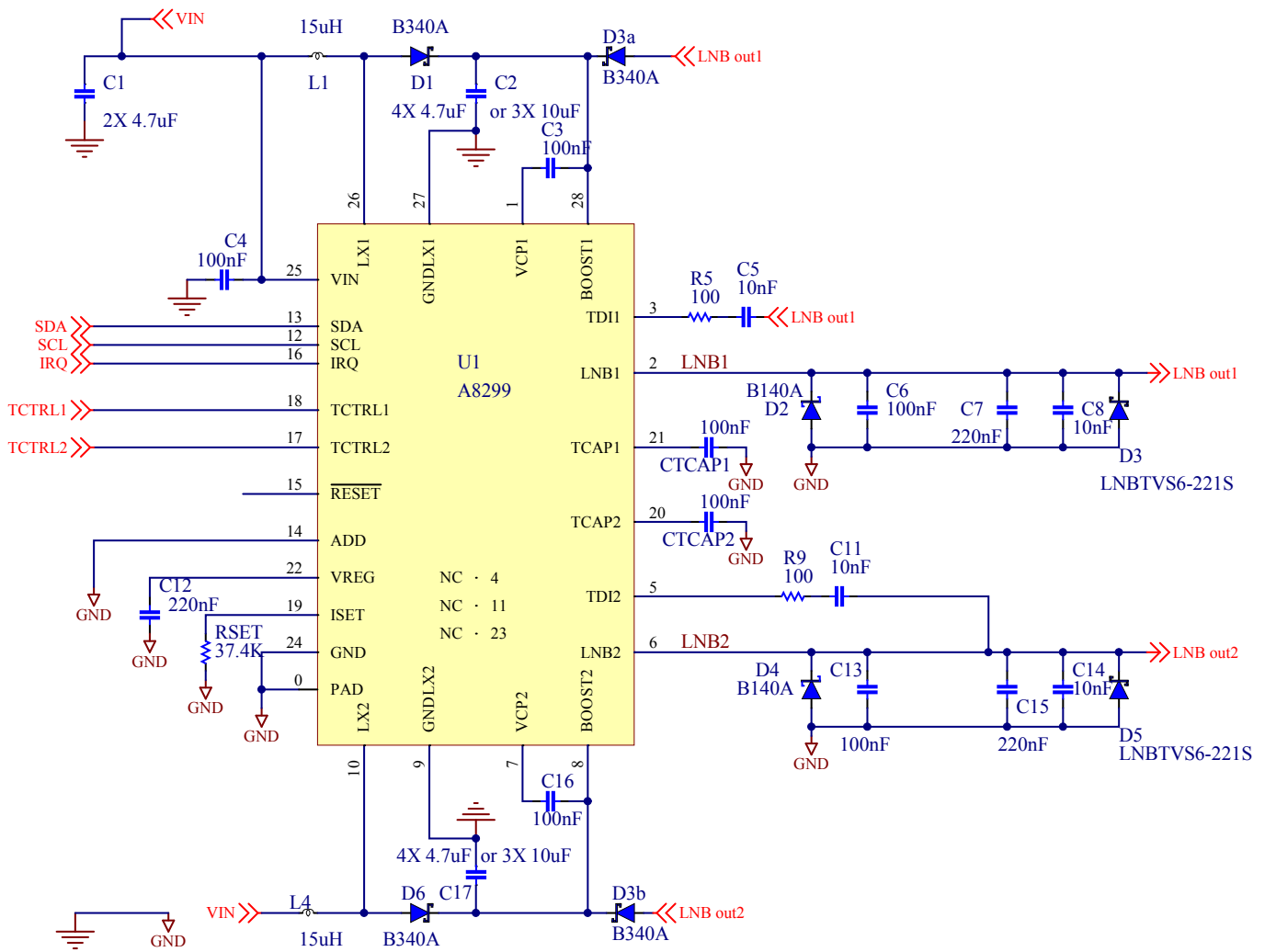

PGND and GND form a single point ground at U1

See table 6 for bill of materials

Schematic 2. DiSEqC 1.0 Applications, 12 V_{IN} ±10%, 700 mA I_{OUT}, surge of ±1000 V, 2 Ω, 1.2/50 μs – 8/20 μs combination wave

Table 6. Component Selection Table for Schematics 1 and 2

Component	Characteristics	Recommended Device	Comments
C1	2X: 4.7 μ F, 25 V, X5R or X7R, 1206		
C2, C17	4X: 4.7 μ F, \pm 10%, 50 V, X7R, 1210 or 3X: 10 μ F, \pm 10%, 35 V, X7R, 1210	4.7 μ F: Murata: GRM32ER71H475KA88 Taiyo Yuden: UMK325B7475KM AVX: 12105C475KAT2A 10 μ F: Murata: GCM32ER71E106K	
C3,C4,C6, C13,C16, CTCAP1, CTCAP2	100 nF, 50 V, X5R or X7R, 0603		
C5,C8, C11,C14	10 nF, 50 V, X5R or X7R, 0603		
C7,C15	220 nF, 50 V, X5R or X7R, 0603		
C12	220 nF, 10 V (min) , X5R or X7R, 0603		
D1,D6	Schottky diode, 3 A, 40 V, SMA	Sanken: SFPB-74 Vishay: B340A-E3/5AT Diodes, Inc.: B340A-13-F Central Semiconductor: CSMH3-40MA	
D2, D4	Schottky diode, 1 A, 40 V, SOD-123	Diodes, Inc.: B140HW-7 Central Semiconductor: CMMSH1-40	
D3a, D3b	Schottky diode, 1 A, 40 V, SOD-123	Diodes, Inc.: B140HW-7 Central Semiconductor: CMMSH1-40	For DiSEqC 2.0 Applications
	Schottky diode, 3 A, 40 V, SMA	Sanken: SFPB-74 Vishay: B340A-E3/5AT Diodes, Inc.: B340A-13-F Central Semiconductor: CSMH3-40MA	For DiSEqC 1.0 Applications
D3,D5	TVS, 20 VRM, 32 VCL at 500 A, 3000 W	Littelfuse: SMDJ20A ST: LNBTVS6-221S	
L1,L4	15 μ H, \pm 20%, $I_{SAT} \geq 3.1$ A, DCR < 75 m Ω	Cooper Bussmann: DR1040-150-R TDK: VLF10045T-150M3R5 Sumida: CDRH10D43FBNP-150M	
L2,L3	220 μ H, \pm 20%, $I_{SAT} \geq 800$ mA, DCR < 0.8 Ω	Cooper Bussmann: DR1040-221-R TDK: VLF10045T-221MR90	Short for DiSEqC 1.0 Applications
Q2,Q3	MOSFET, P-channel, 50 V, < 0.5 Ω , SOT-23	Vishay: SI2309DS-T1-E3 Diodes, Inc.: ZXMP6A13FTA	N. P. for DiSEqC 1.0 Applications
Q1,Q4	Transistor, NPN, 50 V, 100 mA, SOT-323	Diodes, Inc.: BC846AW-7-F NXP: BC846W ON Semiconductor: BC846AWT1G	N. P. for DiSEqC 1.0 Applications
R1,R2, R3,R13, R14,R15	Resistor, 10 k Ω , 1%, 0402 or 0603		N. P. for DiSEqC 1.0 Applications
R4,R12	Resistor, 2.0 Ω , 1%, 0603		N. P. for DiSEqC 1.0 Applications
R5,R9	Resistor, 100 Ω , 1%, 0402 or 0603		
R6,R11	Resistor, 15 Ω , 1%, 0402 or 0603		N. P. for DiSEqC 1.0 Applications
RSET	Resistor, 37.4 k Ω , 1%, 0402 or 0603		
U1	A8299 MLPQ-28, 5 x 5 mm		

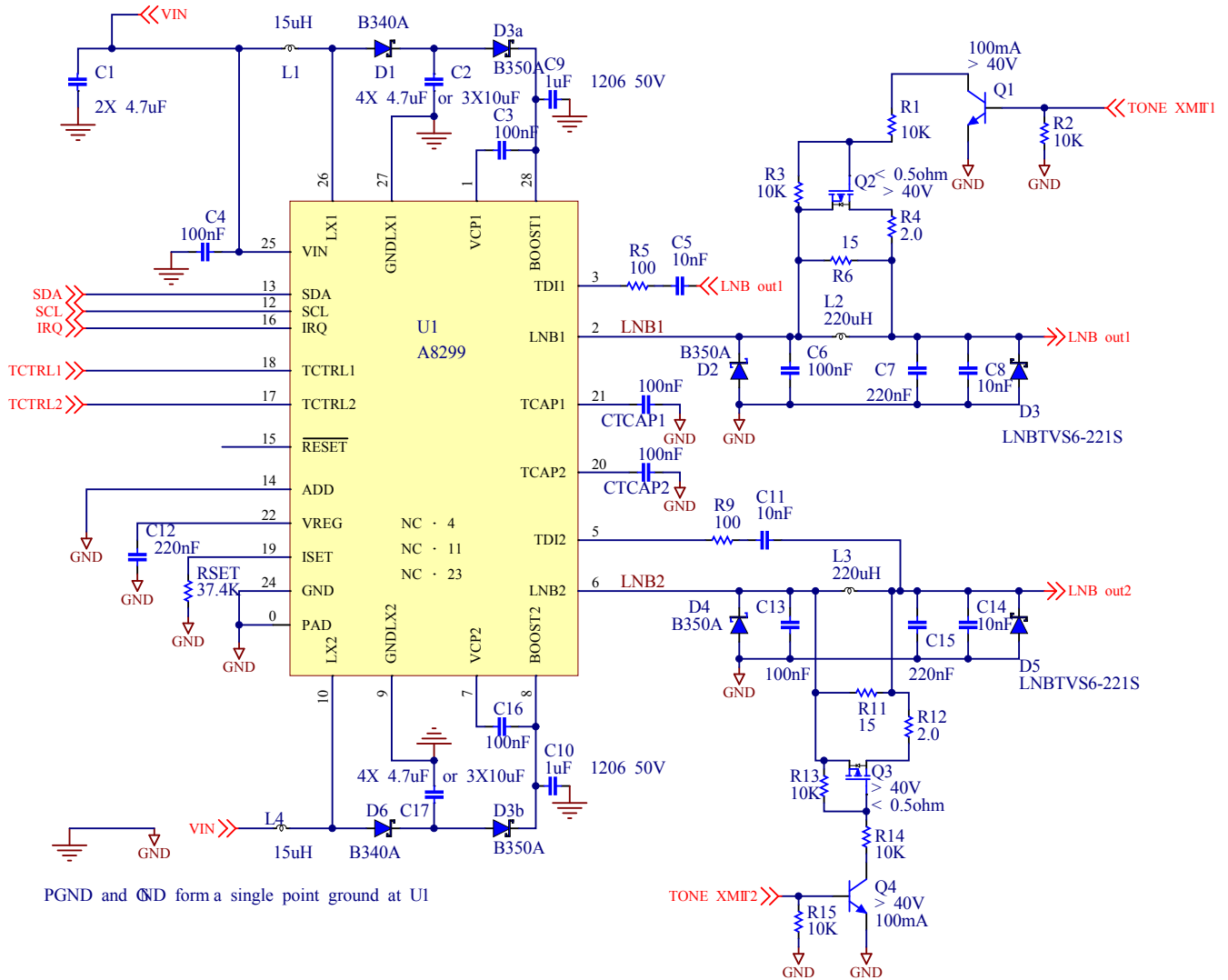

See table 7 for bill of materials

Schematic 3. DiSEqC 2.0 Applications for increased surge requirements ± 1000 V, 2Ω , $1.2/50 \mu\text{s} - 8/20 \mu\text{s}$ combination wave, and "stress to TVS failure" (or ± 4000 V) test

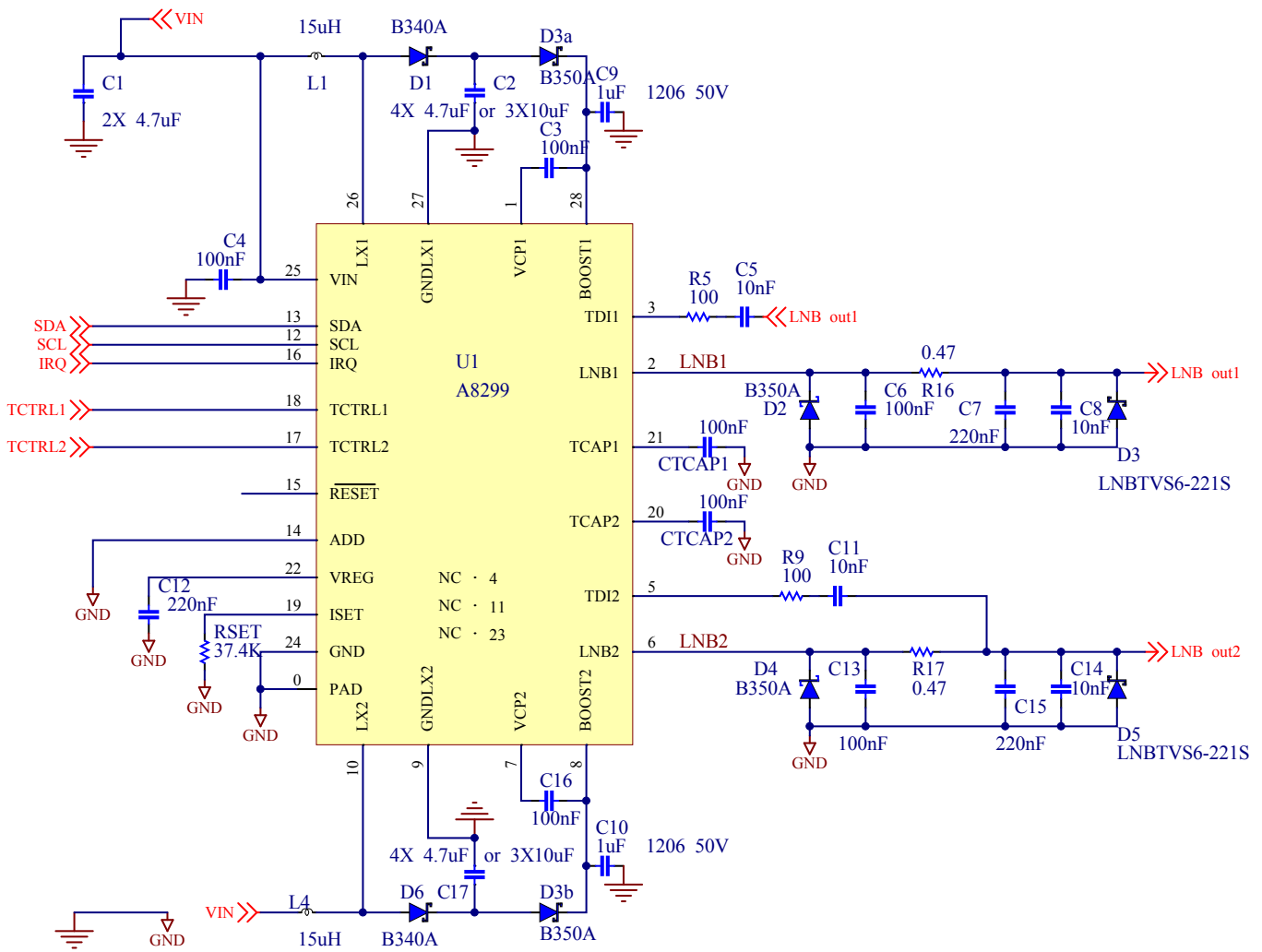

PGND and GND form a single point ground at U1

See table 7 for bill of materials

Schematic 4. DiSEqC 1.0 Applications for increased surge requirements ±1000 V, 2 Ω, 1.2/50 μs – 8/20 μs combination wave, and “stress to TVS failure” (or ±4000 V) test

Table 7. Component Selection Table for Schematics 3 and 4

Component	Characteristics	Recommended Device	Comments
C1	2X: 4.7 μ F, 25 V, X5R or X7R, 1206		
C2, C17	4X: 4.7 μ F, \pm 10%, 50 V, X7R, 1210 or 3X: 10 μ F, \pm 10%, 35 V, X7R, 1210	4.7 μ F: Murata: GRM32ER71H475KA88 Taiyo Yuden: UMK325B7475KM AVX: 12105C475KAT2A 10 μ F: Murata: GCM32ER71E106K	
C3,C4,C6, C13,C16, CTCAP1, CTCAP2	100 nF, 50 V, X5R or X7R, 0603		
C5,C8, C11,C14	10 nF, 50 V, X5R or X7R, 0603		
C7,C15	220 nF, 50 V, X5R or X7R, 0603		
C9,C10	1 μ F, 50 V, 10%, X7R	Murata: GRM31CR71H105KA61L	
C12	220 nF, 10 V (min.), X5R or X7R, 0603		
D1,D6	Schottky diode, 3 A, 40 V, SMA	Sanken: SFPB-74 Vishay: B340A-E3/5AT Diodes, Inc.: B340A-13-F Central Semiconductor: CSMH3-40MA	
D2,D3a, D3b,D4	Schottky diode, 3 A, 50 V, SMA	Diodes, Inc.: B350A-13-F Vishay: B350A-E3/5AT	
D3,D5	TVS, 20 VRM, 32 VCL at 500 A, 3000 W	Littelfuse: SMDJ20A ST: LNBTVS6-221S	
L1,L4	15 μ H, \pm 20%, ISAT \geq 3.1 A, DCR < 75 m Ω	Cooper Bussmann: DR1040-150-R TDK: VLF10045T-150M3R5 Sumida: CDRH10D43FBNP-150M	
L2,L3	220 μ H, \pm 20%, ISAT \geq 800 mA, DCR < 0.8 Ω	Cooper Bussmann: DR1040-221-R TDK: VLF10045T-221MR90	Short for DiSEqC 1.0 Applications
Q2,Q3	MOSFET, P-channel, 50 V, < 0.5 Ω , SOT-23	Vishay: SI2309DS-T1-E3 Diodes, Inc.: ZXMP6A13FTA	N. P. for DiSEqC 1.0 Applications
Q1,Q4	Transistor, NPN, 50 V, 100 mA, SOT-323	Diodes, Inc.: BC846AW-7-F NXP: BC846W ON Semiconductor: BC846AWT1G	N. P. for DiSEqC 1.0 Applications
R1,R2,R3, R13, R14,R15	Resistor, 10 k Ω , 1%, 0402 or 0603		N. P. for DiSEqC 1.0 Applications
R4,R12	Resistor, 2.0 Ω , 1%, 0603		N. P. for DiSEqC 1.0 Applications
R5,R9	Resistor, 100 Ω , 1%, 0402 or 0603		
R6,R11	Resistor, 15 Ω , 1%, 0402 or 0603		N. P. for DiSEqC 1.0 Applications
R16,R17	Resistor, 0.47 Ω , 1/4 W, 1%, 1206	Rohm: MCR18EZHFLR470	N. P. for DiSEqC 2.0 Applications
RSET	Resistor, 37.4 k Ω , 1%, 0402 or 0603		
U1	A8299 MLPQ-28 5 x 5 mm		

Package ET 28-Pin MLP/QFN

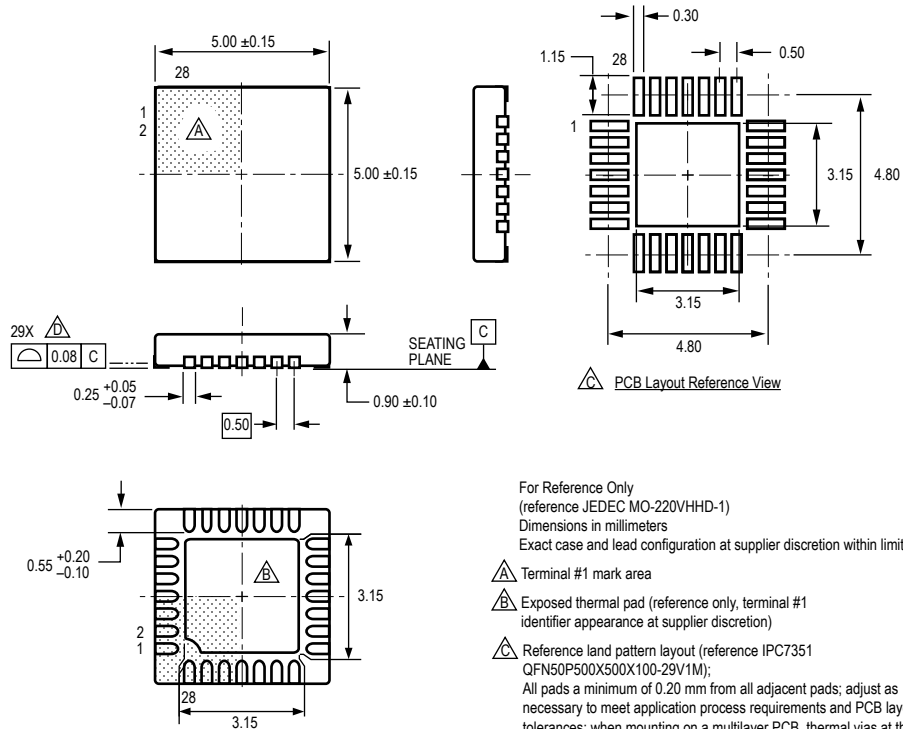

For Reference Only
 (reference JEDEC MO-220V/HHD-1)
 Dimensions in millimeters
 Exact case and lead configuration at supplier discretion within limits shown

- \triangle Terminal #1 mark area
- \triangle Exposed thermal pad (reference only, terminal #1 identifier appearance at supplier discretion)
- \triangle Reference land pattern layout (reference IPC7351 QFN50P500X500X100-29V1M); All pads a minimum of 0.20 mm from all adjacent pads; adjust as necessary to meet application process requirements and PCB layout tolerances; when mounting on a multilayer PCB, thermal vias at the exposed thermal pad land can improve thermal dissipation (reference EIA/JEDEC Standard JESD51-5)
- \triangle Coplanarity includes exposed thermal pad and terminals

Revision History

Number	Date	Description
1	July 9, 2018	Minor editorial updates
2	February 8, 2019	Product status changed to Pre-End-of-Life

I²C™ is a trademark of Philips Semiconductors.

DiSEqC™ is a trademark of Eutelsat S.A.

Copyright ©2019, Allegro MicroSystems, LLC

Allegro MicroSystems, LLC reserves the right to make, from time to time, such departures from the detail specifications as may be required to permit improvements in the performance, reliability, or manufacturability of its products. Before placing an order, the user is cautioned to verify that the information being relied upon is current.

Allegro's products are not to be used in any devices or systems, including but not limited to life support devices or systems, in which a failure of Allegro's product can reasonably be expected to cause bodily harm.

The information included herein is believed to be accurate and reliable. However, Allegro MicroSystems, LLC assumes no responsibility for its use; nor for any infringement of patents or other rights of third parties which may result from its use.

Copies of this document are considered uncontrolled documents.

For the latest version of this document, visit our website:

www.allegromicro.com

X-ON Electronics

Largest Supplier of Electrical and Electronic Components

Click to view similar products for [Voltage References](#) category:

Click to view products by [Allegro](#) manufacturer:

Other Similar products are found below :

[622664A](#) [636116E](#) [748389C](#) [AS431ARTR-E1](#) [NCP431BCSNT1G](#) [NCP432BCSNT1G](#) [NCV431BSNT1G](#) [AP4313UKTR-G1](#)
[TL1431AIYDT](#) [AZ431BR-ATRE1](#) [622668D](#) [NCP432BVSNT1G](#) [5962-8686103XC](#) [NCV431BVDMR2G](#) [AZ432BNTR-G1](#)
[AP4306BUKTR-G1](#) [SC431BVSNT1G](#) [MAX6023EBT30+T](#) [NCV431ASNT1G](#) [LM4040CEM3-5.0/V+T](#) [LT1460KCS3-3#TRM](#)
[LT1460KCS3-3.3#TRM](#) [LT6660KCDC-10#TRMPBF](#) [LTC6652BHLS8-5#PBF](#) [LTC6652AHLS8-4.096#PBF](#) [LTC6655BHLS8-4.096#PBF](#)
[LT6660HCDC-5#TRMPBF](#) [LM336Z-2.5#PBF](#) [LT1021BMH-10](#) [SC431ILPRAG](#) [TLVH431MIL3T](#) [MAX6023EBT21+T](#) [AP432AQG-7](#)
[ADR4540CRZ](#) [LM4040B25QFTA](#) [TS3325AQPR](#) [REF102AU/2K5](#) [TL4050B25QDBZR](#) [TL4051C12QDCKR](#) [TL431ACZ](#) [KA431SLMF2TF](#)
[KA431SMF2TF](#) [KA431SMFTF](#) [LM385BXZ/NOPB](#) [LM4040QCEM3-3.0/NOPB](#) [LM4041C12ILPR](#) [LM4050AEM3X-5.0/NOPB](#)
[LM4050AIM3X-5.0/NOPB](#) [LM4120AIM5-2.5/NOP](#) [LM431SCCMFX](#)