



3.3V 128K X 8 CMOS SRAM (Center power and ground)

Features

- Industrial and commercial temperatures
 - Organization: 131,072 x 8 bits
 - High speed
 - 10 ns address access time
 - 5 ns output enable access time
 - Low power consumption via ship deselect
 - Easy memory expansion with CE, OE inputs
 - Center power and ground
 - TTL/LVTTL-compatible, three-state I/O
 - JEDEC-standard packages
- 32-pin, 300 mil SOJ
 - 32-pin, 400 mil SOJ
 - 32-pin, TSOP 2
 - ESD protection ≥ 2000 volts

Logic block diagram

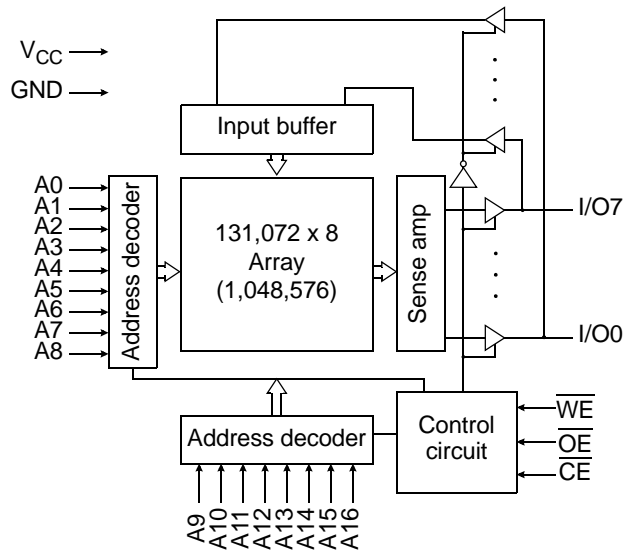

Pin arrangement

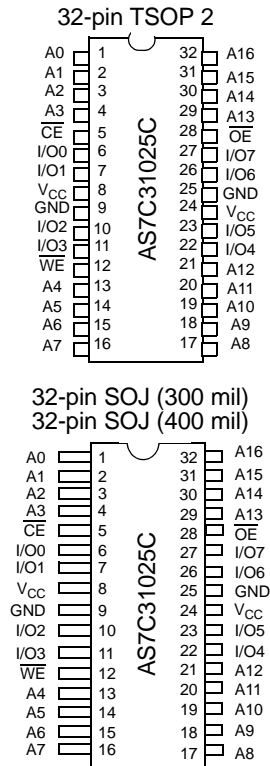



Functional description

The AS7C31025C is 3V a high-performance CMOS 1,048,576-bit Static Random Access Memory (SRAM) device organized as 131,072 x 8 bits. It is designed for memory applications where fast data access, low power, and simple interfacing are desired.

Equal address access and cycle times (t_{AA} , t_{RC} , t_{WC}) of 10 ns with output enable access times (t_{OE}) of 5 ns are ideal for high-performance applications. The chip enable input \overline{CE} permits easy memory and expansion with multiple-bank memory systems.

When \overline{CE} is high the device enters standby mode. A write cycle is accomplished by asserting write enable (\overline{WE}) and chip enable (\overline{CE}). Data on the input pins I/O0 through I/O7 is written on the rising edge of \overline{WE} (write cycle 1) or \overline{CE} (write cycle 2). To avoid bus contention, external devices should drive I/O pins only after outputs have been disabled with output enable (\overline{OE}) or write enable (\overline{WE}).

A read cycle is accomplished by asserting output enable (\overline{OE}) and chip enable (\overline{CE}), with write enable (\overline{WE}) high. The chip drives I/O pins with the data word referenced by the input address. When either chip enable or output enable is inactive or write enable is active, output drivers stay in high-impedance mode.

All chip inputs and outputs are TTL-compatible, and operation is from a single 3.3 V supply. The AS7C31025C is packaged in common industry standard packages.

Absolute maximum ratings

| Parameter | Symbol | Min | Max | Unit |
|---|------------|-------|----------------|------|
| Voltage on V_{CC} relative to GND | V_{t1} | -0.50 | +4.6 | V |
| Voltage on any pin relative to GND | V_{t2} | -0.50 | $V_{CC} + 0.5$ | V |
| Power dissipation | P_D | - | 1.25 | W |
| Storage temperature (plastic) | T_{stg} | -55 | +125 | °C |
| Ambient temperature with V_{CC} applied | T_{bias} | -55 | +125 | °C |
| DC current into outputs (low) | I_{OUT} | - | 50 | mA |

NOTE: Stresses greater than those listed under *Absolute Maximum Ratings* may cause permanent damage to the device. This is a stress rating only and functional operation of the device at these or any other conditions outside those indicated in the operational sections of this specification is not implied. Exposure to absolute maximum rating conditions for extended periods may affect reliability.

Truth table

| \overline{CE} | \overline{WE} | \overline{OE} | Data | Mode |
|-----------------|-----------------|-----------------|-----------|----------------------------------|
| H | X | X | High Z | Standby (I_{SB} , I_{SB1}) |
| L | H | H | High Z | Output disable (I_{CC}) |
| L | H | L | D_{OUT} | Read (I_{CC}) |
| L | L | X | D_{IN} | Write (I_{CC}) |

Key: X = don't care, L = low, H = high.



Recommended operating conditions

| Parameter | Symbol | Min | Nominal | Max | Unit |
|--|----------|------|---------|----------------|------|
| Supply voltage | V_{CC} | 3.0 | 3.3 | 3.6 | V |
| Input voltage | V_{IH} | 2.0 | – | $V_{CC} + 0.3$ | V |
| | V_{IL} | -0.5 | – | 0.8 | V |
| Ambient operating temperature (Industrial) | T_A | -40 | – | 85 | °C |

V_{IL} min = -2.0V for pulse width less than 5ns, once per cycle.

V_{IH} min = $-V_{CC} + 2.0V$ for pulse width less than 5ns, once per cycle.

DC operating characteristics (over the operating range)¹

| Parameter | Sym | Test conditions | AS7C31025C-10 | | Unit |
|---|------------|---|---------------|-----|---------------|
| | | | Min | Max | |
| Input leakage current | $ I_{LI} $ | $V_{CC} = \text{Max}, V_{IN} = \text{GND to } V_{CC}$ | – | 5 | μA |
| Output leakage current | $ I_{LO} $ | $V_{CC} = \text{Max}, \overline{CE} = V_{IH},$ $V_{out} = \text{GND to } V_{CC}$ | – | 5 | μA |
| Operating power supply current | I_{CC} | $V_{CC} = \text{Max}$ $\overline{CE} \leq V_{IL}, f = f_{\text{Max}},$ $I_{OUT} = 0 \text{ mA}$ | – | 150 | mA |
| Standby power supply current ¹ | I_{SB} | $V_{CC} = \text{Max}$ $\overline{CE} \geq V_{IH}, f = f_{\text{Max}}$ | – | 50 | mA |
| | I_{SB1} | $V_{CC} = \text{Max}, \overline{CE} \geq V_{CC} - 0.2 \text{ V},$ $V_{IN} \leq 0.2 \text{ V or } V_{IN} \geq V_{CC} - 0.2 \text{ V},$ $f = 0$ | – | 10 | mA |
| Output voltage | V_{OL} | $I_{OL} = 8 \text{ mA}, V_{CC} = \text{Min}$ | – | 0.4 | V |
| | V_{OH} | $I_{OH} = -4 \text{ mA}, V_{CC} = \text{Min}$ | 2.4 | – | V |

Capacitance ($f = 1 \text{ MHz}, T_a = 25^\circ \text{ C}, V_{CC} = \text{NOMINAL}$)²

| Parameter | Symbol | Signals | Test conditions | Max | Unit |
|-------------------|-----------|--|------------------------|-----|------|
| Input capacitance | C_{IN} | A, \overline{CE} , \overline{WE} , \overline{OE} | $V_{IN} = 3\text{dV}$ | 6 | pF |
| I/O capacitance | $C_{I/O}$ | I/O | $V_{OUT} = 3\text{dV}$ | 7 | pF |

Note:

1. This parameter is guaranteed by device characterization, but is not production tested.



Read cycle (over the operating range)^{3,9}

| Parameter | Symbol | AS7C31025C-10 | | Unit | Notes |
|---|-----------|---------------|-----|------|-------|
| | | Min | Max | | |
| Read cycle time | t_{RC} | 10 | – | ns | |
| Address access time | t_{AA} | – | 10 | ns | 3 |
| Chip enable (\overline{CE}) access time | t_{ACE} | – | 10 | ns | 3 |
| Output enable (\overline{OE}) access time | t_{OE} | – | 5 | ns | |
| Output hold from address change | t_{OH} | 4 | – | ns | 5 |
| \overline{CE} low to output in low Z | t_{CLZ} | 4 | – | ns | 4, 5 |
| \overline{CE} high to output in high Z | t_{CHZ} | 0 | 5 | ns | 4, 5 |
| \overline{OE} low to output in low Z | t_{OLZ} | 0 | – | ns | 4, 5 |
| \overline{OE} high to output in high Z | t_{OHZ} | 0 | 5 | ns | 4, 5 |
| Power up time | t_{PU} | 0 | – | ns | 4, 5 |
| Power down time | t_{PD} | – | 10 | ns | 4, 5 |

Key to switching waveforms

 Rising input
  Falling input
  Undefined/don't care

Read waveform 1 (address controlled)^{3,6,7,9}

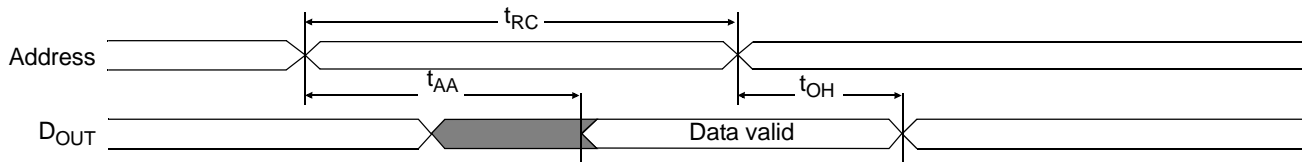

Read waveform 2 (\overline{CE} and \overline{OE} controlled)^{3,6,8,9}

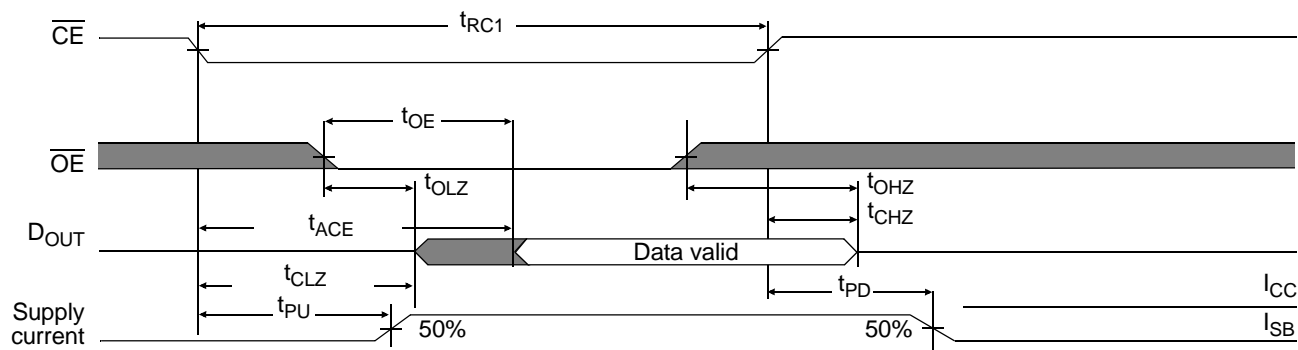



Write cycle (over the operating range)¹¹

| Parameter | Symbol | AS7C31025C-10 | | Unit | Notes |
|--|----------|---------------|-----|------|-------|
| | | Min | Max | | |
| Write cycle time | t_{WC} | 10 | – | ns | |
| Chip enable (\overline{CE}) to write end | t_{CW} | 7 | – | ns | |
| Address setup to write end | t_{AW} | 7 | – | ns | |
| Address setup time | t_{AS} | 0 | – | ns | |
| Write pulse width | t_{WP} | 7 | – | ns | |
| Write recovery time | t_{WR} | 0 | – | ns | |
| Address hold from end of write | t_{AH} | 0 | – | ns | |
| Data valid to write end | t_{DW} | 5 | – | ns | |
| Data hold time | t_{DH} | 0 | – | ns | 4, 5 |
| Write enable to output in high Z | t_{WZ} | 0 | 5 | ns | 4, 5 |
| Output active from write end | t_{OW} | 3 | – | ns | 4, 5 |

Write waveform 1 (\overline{WE} controlled)^{10,11}

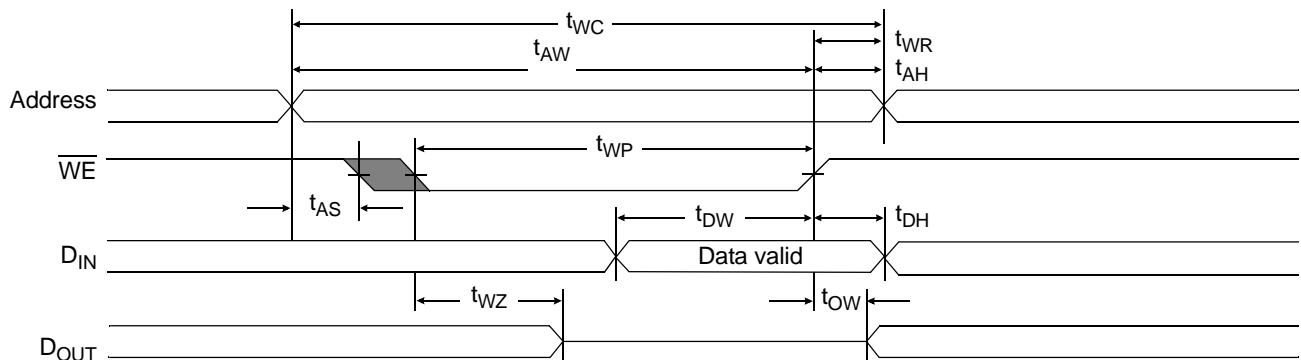

Write waveform 2 (\overline{CE} controlled)^{10,11}

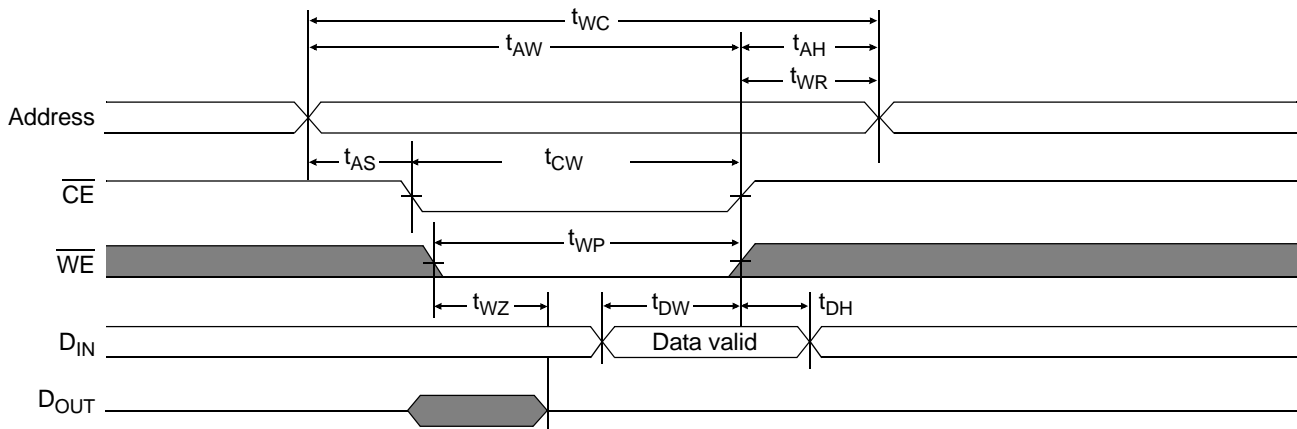



AC test conditions

- Output load: see Figure B.
- Input pulse level: GND to 3.0 V. See Figure A.
- Input rise and fall times: 3 ns. See Figure A.
- Input and output timing reference levels: 1.5 V.

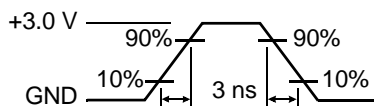

Figure A: Input pulse

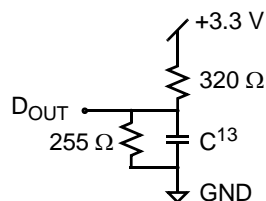
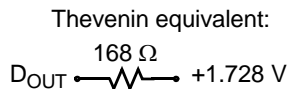

Figure B: 3.3 V Output load

Notes

- 1 During V_{CC} power-up, a pull-up resistor to V_{CC} on \overline{CE} is required to meet I_{SB} specification.
- 2 This parameter is sampled, but not 100% tested.
- 3 For test conditions, see *AC Test Conditions*, Figures A and B.
- 4 t_{CLZ} and t_{CHZ} are specified with $C_L = 5$ pF, as in Figure B. Transition is measured ± 200 mV from steady-state voltage.
- 5 This parameter is guaranteed, but not 100% tested.
- 6 \overline{WE} is high for read cycle.
- 7 \overline{CE} and \overline{OE} are low for read cycle.
- 8 Address is valid prior to or coincident with \overline{CE} transition low.
- 9 All read cycle timings are referenced from the last valid address to the first transitioning address.
- 10 N/A
- 11 All write cycle timings are referenced from the last valid address to the first transitioning address.
- 12 N/A.
- 13 $C = 30$ pF, except all high Z and low Z parameters where $C = 5$ pF.



Package dimensions

32-pin TSOP 2

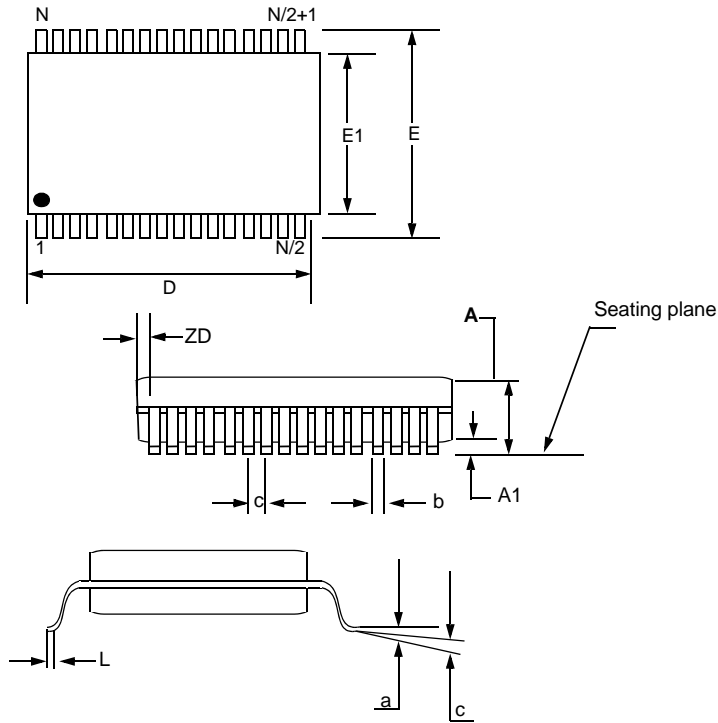

| Symbol | 32-pin TSOP 2 (mm) | |
|----------|--------------------|-------|
| | Min | Max |
| A | - | 1.20 |
| A1 | 0.05 | 0.15 |
| b | 0.3 | 0.52 |
| C | 0.12 | 0.21 |
| D | 20.82 | 21.08 |
| E1 | 10.03 | 10.29 |
| E | 11.56 | 11.96 |
| e | 1.27 BSC | |
| L | 0.40 | 0.60 |
| ZD | 0.95 REF. | |
| α | 0° | 5° |

32-pin SOJ
300 mil/400 mil

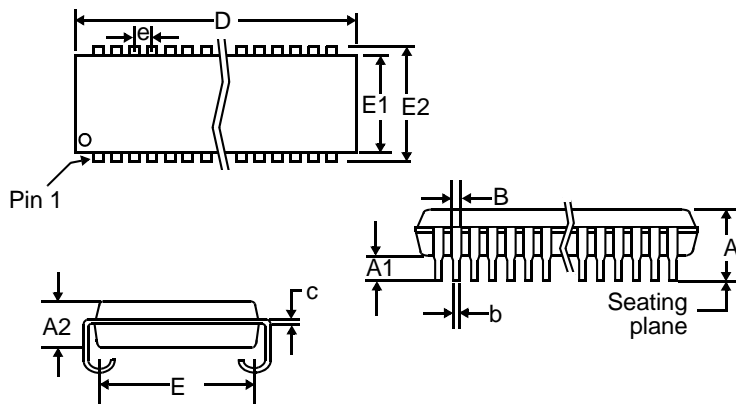

| Symbol | 32-pin SOJ 300 mil | | 32-pin SOJ 400 mil | |
|--------|-----------------------|-------|-----------------------|-------|
| | Min | Max | Min | Max |
| A | 0.128 | 0.145 | 0.132 | 0.146 |
| A1 | 0.025 | - | 0.025 | - |
| A2 | 0.095 | 0.105 | 0.105 | 0.115 |
| B | 0.026 | 0.032 | 0.026 | 0.032 |
| b | 0.016 | 0.020 | 0.015 | 0.020 |
| c | 0.007 | 0.010 | 0.007 | 0.013 |
| D | 0.820 | 0.830 | 0.820 | 0.830 |
| E | 0.255 | 0.275 | 0.354 | 0.378 |
| E1 | 0.295 | 0.305 | 0.395 | 0.405 |
| E2 | 0.330 | 0.340 | 0.435 | 0.445 |
| e | 0.050 BSC | | 0.050 BSC | |



Ordering Codes

| Package | Volt/Temperature | 10 ns |
|-------------|------------------|-------------------|
| 300-mil SOJ | 5V Industrial | AS7C31025C-10TJIN |
| 400-mil SOJ | 5V Industrial | AS7C31025C-10JIN |
| TSOP 2 | 5V Industrial | AS7C31025C-10TIN |

Part numbering system

| AS7C | X | 1025B | -XX | X | X | X |
|-------------|-------------------------------|------------------|-------------|--|---|--------------------|
| SRAM prefix | Voltage: 3 = 3.3 V CMOS | Device number | Access time | Package: TJ = SOJ 300 mil J = SOJ 400 mil T = TSOP2 | Temperature range I = industrial, -40° C to 85° C | N = Lead Free Part |

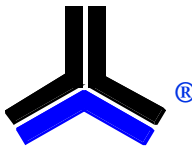

Alliance Memory, Inc.
1116 South Amphlett
San Mateo, CA 94402
Tel: 650-525-3737
Fax: 650-525-0449

www.alliancememory.com

Copyright © Alliance Memory

All Rights Reserved

Part Number: AS7C31025C

Document Version: v. 1.0

© Copyright 2003 Alliance Memory, Inc. All rights reserved. Our three-point logo, our name and Intelliwatt are trademarks or registered trademarks of Alliance. All other brand and product names may be the trademarks of their respective companies. Alliance reserves the right to make changes to this document and its products at any time without notice. Alliance assumes no responsibility for any errors that may appear in this document. The data contained herein represents Alliance's best data and/or estimates at the time of issuance. Alliance reserves the right to change or correct this data at any time, without notice. If the product described herein is under development, significant changes to these specifications are possible. The information in this product data sheet is intended to be general descriptive information for potential customers and users, and is not intended to operate as, or provide, any guarantee or warrantee to any user or customer. Alliance does not assume any responsibility or liability arising out of the application or use of any product described herein, and disclaims any express or implied warranties related to the sale and/or use of Alliance products including liability or warranties related to fitness for a particular purpose, merchantability, or infringement of any intellectual property rights, except as expressly agreed to in Alliance's Terms and Conditions of Sale (which are available from Alliance). All sales of Alliance products are made exclusively according to Alliance's Terms and Conditions of Sale. The purchase of products from Alliance does not convey a license under any patent rights, copyrights; mask works rights, trademarks, or any other intellectual property rights of Alliance or third parties. Alliance does not authorize its products for use as critical components in life-supporting systems where a malfunction or failure may reasonably be expected to result in significant injury to the user, and the inclusion of Alliance products in such life-supporting systems implies that the manufacturer assumes all risk of such use and agrees to indemnify Alliance against all claims arising from such use.

X-ON Electronics

Largest Supplier of Electrical and Electronic Components

Click to view similar products for [SRAM](#) category:

Click to view products by [Alliance Memory](#) manufacturer:

Other Similar products are found below :

[CY6116A-35DMB](#) [CY7C1049GN-10VXI](#) [CY7C1461KV33-133AXI](#) [GS8161Z36DD-200I](#) [GS88237CB-200I](#) [RMLV0408EGSB-4S2#AA0](#)
[IS64WV3216BLL-15CTLA3](#) [IS66WVE4M16ECLL-70BLI](#) [PCF8570P](#) [K6F2008V2E-LF70000](#) [K6T4008C1B-GB70](#) [CY7C1353S-100AXC](#)
[AS6C8016-55BIN](#) [AS7C164A-15PCN](#) [515712X](#) [IS62WV51216EBLL-45BLI](#) [IS63WV1288DBLL-10HLI](#) [IS66WVE2M16ECLL-70BLI](#)
[IS66WVE4M16EALL-70BLI](#) [IS61WV102416DBLL-10TLI](#) [CY7C1381KV33-100AXC](#) [CY7C1460KV25-200BZI](#) [CY7C1373KV33-100AXC](#)
[CY7C1381KVE33-133AXI](#) [CY7C4121KV13-600FCXC](#) [GS882Z18CD-150I](#) [IS66WVC2M16ECLL-7010BLI](#) [7140LA35PDG](#)
[CY7C1380KV33-250AXC](#) [AS6C8016-55BINTR](#) [CY7C1370KV33-250AXC](#) [CY7C1370KVE33-167AXI](#) [7140LA100PDG](#) [AS7C34096B-](#)
[10TIN](#) [AS6C8016-55TIN](#) [IS62WV25616EALL-55TLI](#) [GS8128418B-167IV](#) [CY7C1460KV25-200BZXI](#) [CY7C1460KV25-167BZXI](#)
[CY7C1315KV18-333BZXC](#) [CY7C1370KV25-200AXC](#) [71421LA55JI8](#) [CY62158G30-45ZSXI](#) [CY62157G30-45ZSXI](#) [RMLV3216AGSD-](#)
[5S2#AA0](#) [CY62187G30-55BAXI](#) [CY62157G30-45ZXI](#) [IS61VVPS102436B-200B3LI](#) [IS66WVC2M16EALL-7010BLI](#)
[IS66WVE4M16EALL-70BLI-TR](#)