

General Description

The AOZ8312 is a transient voltage suppressor array designed to protect high speed data lines from ESD and lightning.

This AOZ8312 incorporates twelve low capacitance steering diodes and a TVS in a single package. During transient conditions, the steering diodes direct the transient to either the positive side of the power supply line or to ground. The AOZ8312 may be used to meet the ESD immunity requirements of IEC 61000-4-2, Level 4 and IEC 61000-4-5. The TVS diodes provide effective suppression of ESD voltages: ± 30 kV (air discharge) and ± 30 kV (contact discharge).

The AOZ8312 comes in a Halogen Free and RoHS compliant 3.5 mm x 2.5 mm x 0.55 mm DFN-12 package and is rated over a -40 °C to $+85$ °C ambient temperature range. The AOZ8312 is compatible with both lead free and SnPb assembly techniques. The small size, low capacitance and high ESD protection makes the AOZ8312 ideal for protecting high speed video and data communication interfaces.

Features

- ESD protection for high-speed data lines:
 - IEC 61000-4-2, level 4 (ESD) immunity test
 - ± 30 kV (air discharge) and ± 30 kV (contact discharge)
 - IEC 61000-4-4 (EFT) 40 A (5/50 ns)
 - IEC 61000-4-5 (Lightning) 18 A
 - Human Body Model (HBM) ± 30 kV
- Small package saves board space
- Low insertion loss
- Protects twelve I/O lines
- Low clamping voltage
- Low operating voltage: 2.5 V
- Green product
- Pb-free device

Applications

- Video graphics cards
- Monitors and flat panel displays
- Digital Video Interface (DVI)
- T1/E1 telecom ports



Typical Application

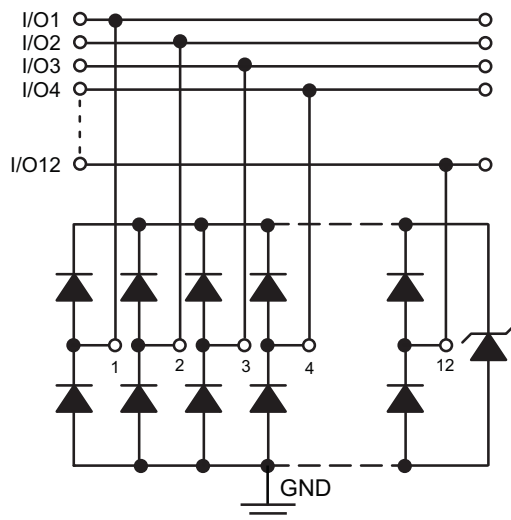

Protection of Twelve Lines

Circuit Diagram

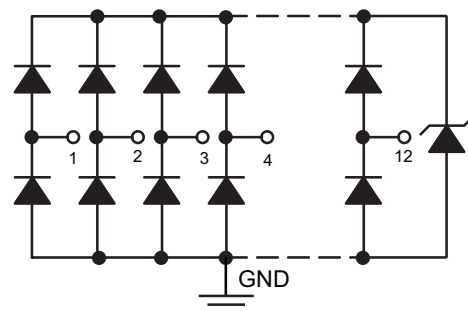

Ordering Information

Part Number	Ambient Temperature Range	Package	Environmental
AOZ8312DI	-40 °C to +85 °C	3.5 mm x 2.5 mm DFN-12	Green Product



AOS Green Products use reduced levels of Halogens, and are also RoHS compliant. Please visit www.aosmd.com/media/AOSGreenPolicy.pdf for additional information.

Pin Configuration

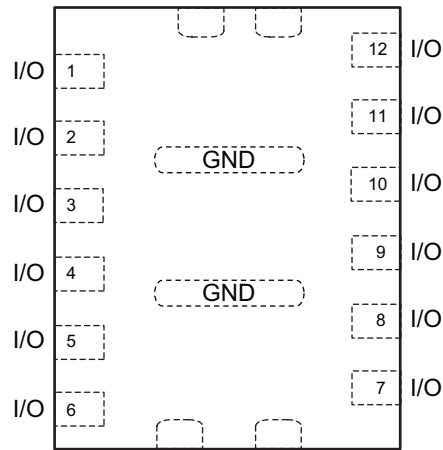

DFN-12
(Top View)

Absolute Maximum Ratings

Exceeding the Absolute Maximum ratings may damage the device.

Parameter	Rating
Peak Pulse Current (I_{PP}), $t_P = 8/20 \mu s$	18 A
Peak Power Dissipation (8 x 20 μs @ 25 °C)	160 W
Storage Temperature (T_S)	-65 °C to +150 °C
ESD Rating per IEC61000-4-2, Contact ⁽¹⁾	±30 kV
ESD Rating per IEC61000-4-2, Air ⁽¹⁾	±30 kV
ESD Rating per Human Body Model ⁽²⁾	±30 kV

Notes:

- IEC 61000-4-2 discharge with $C_{Discharge} = 150 \text{ pF}$, $R_{Discharge} = 330 \Omega$.
- Human Body Discharge per MIL-STD-883, Method 3015 $C_{Discharge} = 100 \text{ pF}$, $R_{Discharge} = 1.5 \text{ k}\Omega$.

Maximum Operating Ratings

Parameter	Rating
Junction Temperature (T_J)	-40 °C to +125 °C

Electrical Characteristics

$T_A = 25^\circ\text{C}$ unless otherwise specified.

Symbol	Parameter	Conditions	Min.	Typ.	Max.	Units
V_{RWM}	Reverse Working Voltage	Between any I/O pin 5 and GND ⁽⁴⁾			2.5	V
I_R	Reverse Leakage Current	$V_{RWM} = 2.5$ V, between any I/O pin 5 and GND			1	μA
V_{BR}	Reverse Breakdown Voltage	$I_T = 100$ μA	2.8			V
V_{CL}	Channel Clamp Voltage Positive Transients	$I_{PP} = 2$ A, $t_p = 8/20$ μs , any I/O pin to GND ⁽³⁾			3.5	V
	Channel Clamp Voltage Positive Transients	$I_{PP} = 10$ A, $t_p = 8/20$ μs , any I/O pin to GND ⁽³⁾			6.5	V
	Channel Clamp Voltage Positive Transients	$I_{PP} = 18$ A, $t_p = 8/20$ μs , any I/O pin to GND ⁽³⁾			9	V
C_j	Junction Capacitance	$V_R = 0$ V, $f = 1$ MHz, any I/O pin to Ground		2.3	3.5	pF
		$V_R = 0$ V, $f = 1$ MHz, between I/O pins ⁽³⁾		1.2		pF

Notes:

3. These specifications are guaranteed by design.
4. The working peak reverse voltage, V_{RWM} , should be equal to or greater than the DC or continuous peak operating voltage level.
5. V_{BR} is measured at the pulse test current I_T .

Typical Performance Characteristics

Clamping Voltage vs. Peak Pulse Current
(IEC6100-4-5 8/20 μ s pulse current)

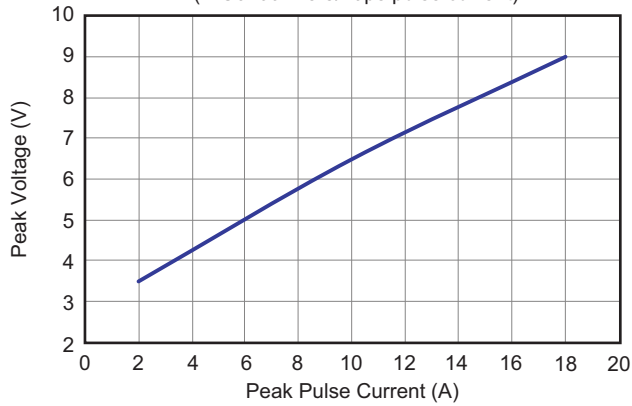

Forward Voltage vs. Forward Current
(IEC6100-4-5 8/20 μ s pulse current)

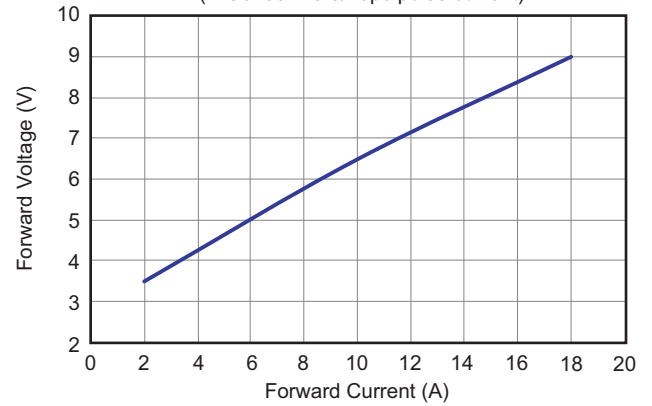

Capacitance vs. Reverse Bias

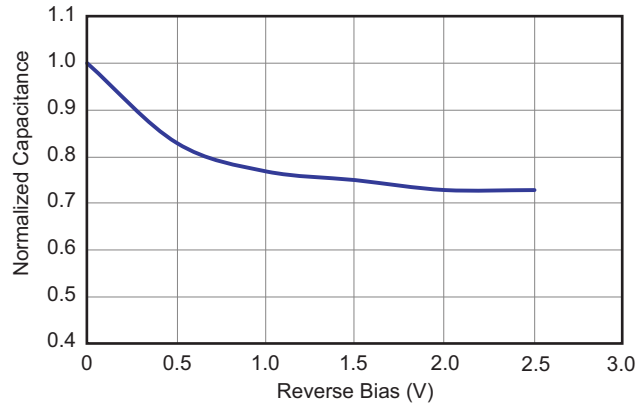

Package Dimensions, DFN 3.5mm x 2.5mm x 0.55mm, 12L, EP2

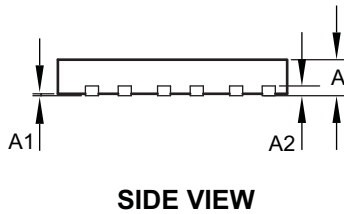
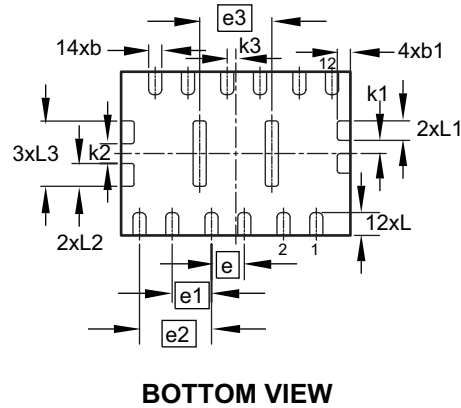
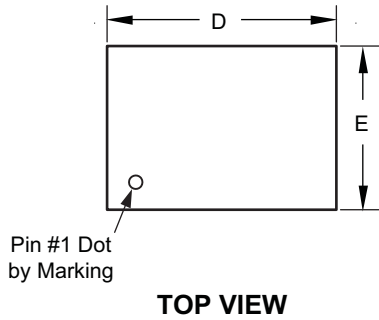

RECOMMENDED LAND PATTERN

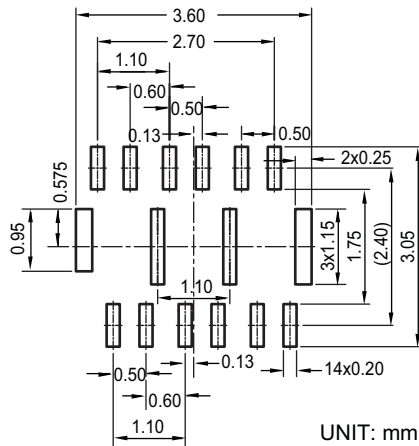

Dimensions in Millimeters Dimensions in Millimeters

Symbols	Min.	Nom.	Max.	Symbols	Min.	Nom.	Max.
A	0.50	0.55	0.60	A	0.020	0.022	0.024
A1	0.00	—	0.05	A1	0.000	—	0.002
A2	(0.15)			A2	(0.006)		
b	0.15	0.20	0.25	b	0.006	0.008	0.010
b1	0.10	0.20	0.30	b1	0.004	0.008	0.012
D	3.40	3.50	3.60	D	0.134	0.138	0.142
E	2.40	2.50	2.60	E	0.094	0.098	0.102
e	0.50 BSC			e	0.020 BSC		
e1	0.60 BSC			e1	0.024 BSC		
e2	1.10 BSC			e2	0.043 BSC		
e3	1.10 BSC			e3	0.043 BSC		
k1	(0.20)			k1	(0.008)		
k2	(0.30)			k2	(0.012)		
k3	(0.13)			k3	(0.005)		
L	0.30	0.35	0.40	L	0.012	0.014	0.016
L1	0.25	0.30	0.35	L1	0.010	0.012	0.014
L2	0.30	0.35	0.40	L2	0.012	0.014	0.016
L3	0.90	1.00	1.10	L3	0.035	0.039	0.043

Notes:

1. Controlling dimension is millimeter. Converted inch dimensions are not necessarily exact.
2. Tolerance: ± 0.05 unless otherwise specified.
3. Radius on all corners is 0.152 max., unless otherwise specified.
4. Package warpage: 0.012 max.
5. No any plastic flash allowed on the top and bottom lead surface.
6. Pad planarity: ± 0.102 .
7. Crack between plastic body and lead is not allowed.

Tape and Reel Dimensions, DFN 3.5mm x 2.5mm x 0.55mm, 12L, EP2

Carrier Tape

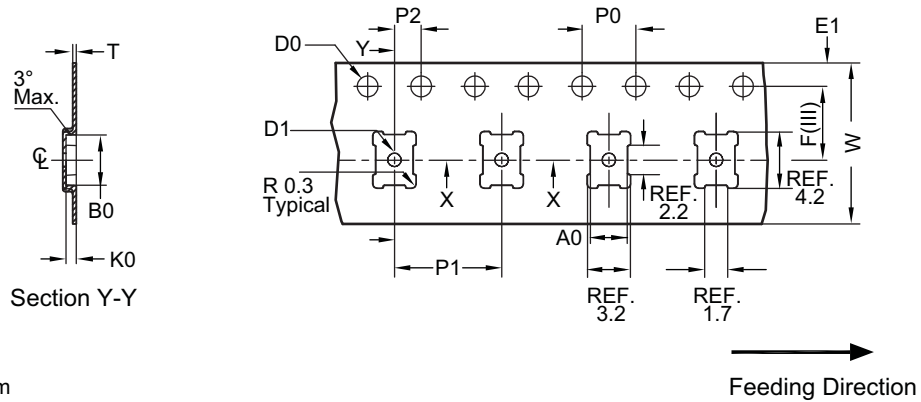

UNIT: mm

Package	A0	B0	K0	D0	D1	W	E1	F	P0	P1	P2	T
DFN 3.5x2.5	2.75 ±0.05	3.75 ±0.05	0.75 ±0.10	1.50 +0.1/-0.0	1.00 +0.1/-0.0	12.00 ±0.30	1.75 ±0.10	5.50 ±0.05	4.00 ±0.10	8.00 ±0.10	2.00 ±0.05	0.25 ±0.05

Reel

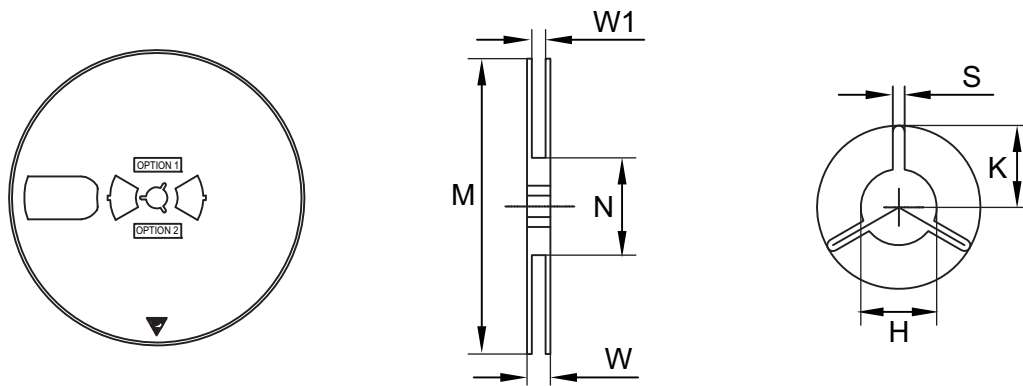

UNIT: mm

Tape Size	Reel Size	M	N	W	W1	H	S	K
12mm	ø178	ø178 ±1.0	ø54 ±0.5	17 ±2.0	13.5 ±0.5	ø13 +0.5/-0.2	2.2 ±0.3	10.25 ±0.2

Leader / Trailer & Orientation

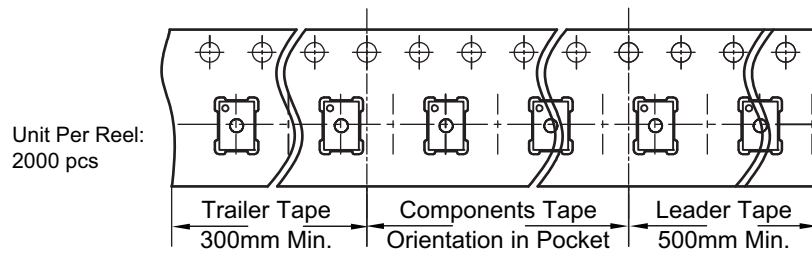

Unit Per Reel:
2000 pcs

Part Marking

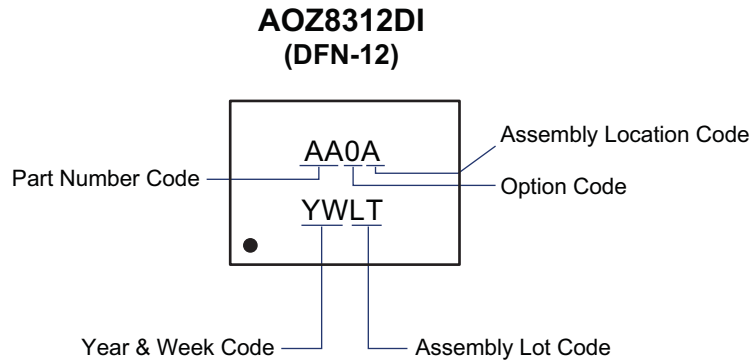

LEGAL DISCLAIMER

Alpha and Omega Semiconductor makes no representations or warranties with respect to the accuracy or completeness of the information provided herein and takes no liabilities for the consequences of use of such information or any product described herein. Alpha and Omega Semiconductor reserves the right to make changes to such information at any time without further notice. This document does not constitute the grant of any intellectual property rights or representation of non-infringement of any third party's intellectual property rights.

LIFE SUPPORT POLICY

ALPHA AND OMEGA SEMICONDUCTOR PRODUCTS ARE NOT AUTHORIZED FOR USE AS CRITICAL COMPONENTS IN LIFE SUPPORT DEVICES OR SYSTEMS.

As used herein:

1. Life support devices or systems are devices or systems which, (a) are intended for surgical implant into the body or (b) support or sustain life, and (c) whose failure to perform when properly used in accordance with instructions for use provided in the labeling, can be reasonably expected to result in a significant injury of the user.
2. A critical component in any component of a life support, device, or system whose failure to perform can be reasonably expected to cause the failure of the life support device or system, or to affect its safety or effectiveness.

X-ON Electronics

Largest Supplier of Electrical and Electronic Components

Click to view similar products for [Alpha & Omega manufacturer:](#)

Other Similar products are found below :

[AO3160](#) [AO3160E](#) [AO3162](#) [AO3401A](#) [AO3402](#) [AO3403](#) [AO3404A](#) [AO3406](#) [AO3407A](#) [AO3409](#) [AO3413](#) [AO3414](#) [AO3415](#) [AO3415A](#)
[AO3416](#) [AO3418](#) [AO3419](#) [AO3420](#) [AO3421E](#) [AO3422](#) [AO3423](#) [AO3424](#) [AO3434A](#) [AO3442](#) [AO3480](#) [AO3481](#) [AO4262E](#) [AO4264E](#)
[AO4266E](#) [AO4286](#) [AO4292E](#) [AO4294](#) [AO4294A](#) [AO4306](#) [AO4354](#) [AO4402](#) [AO4402G](#) [AO4403](#) [AO4404B](#) [AO4406A](#) [AO4406AL](#)
[AO4407A](#) [AO4407C](#) [AO4411](#) [AO4419](#) [AO4421](#) [AO4425](#) [AO4430](#) [AO4435](#) [AO4441](#)