

CLASS No.	TITLE セルフリターンSW 規格書 SELF RETURN SWITCH SPECIFICATION	EC111012000Y (SW01)
-----------	--	------------------------

1. 一般事項 General

1-1 適用範囲 Scope

この仕様書は主として電子機器に用いる微小電流回路用1.1形セルフリターンスイッチに適用する。  
This specification applies to 1.1mm size low-profile self return switch for microscopic current circuits, used in electronic equipment.

1-2 標準状態 Standard atmospheric conditions.

測定は特に指定のない限り、次の状態で行なう。  
Unless otherwise specified, the standard range of atmospheric conditions for making measurements and tests is as follows:

- 温度 Ambient temperature : 15°C to 35°C
- 相対湿度 Relative humidity : 25% to 85%
- 気圧 Air pressure : 86kPa to 106kPa

但し、疑義を生じた場合は、次の基準状態で行なう。

If there is any doubt about the results, measurements shall be made within the following limits:

- 温度 Ambient temperature : 20 ± 1°C
- 相対湿度 Relative humidity : 63% to 67%
- 気圧 Air pressure : 86kPa to 106kPa

1-3 使用温度範囲

Operating temperature range : -40°C to +85°C

1-4 保存温度範囲

Storage temperature range : -40°C to +85°C

2. 構造 Construction

2-1 寸法 Dimensions

添付組立図による。  
Refer to attached drawing.

3. 定格 Rating

3-1 定格容量 Rating : D.C. 5V 10mA (1mA MIN)

4. 電気的性能 Electrical characteristics

項目 Item	条件 Conditions	規格 Specifications
4-1 絶縁抵抗 Insulation resistance	端子-軸受間D.C. 250V印加する。 Measurement shall be made under the condition which a voltage of 250V.D.C. is applied between individual terminals and bushing.	端子-軸受間にて100MΩ以上 Between individual terminals and bushing: 100MΩ MIN.
	端子-端子間(A-C間およびB-C間)にD.C. 50V印加する。(軸がセンター位置にて) Measurement shall be made under the condition which a voltage of 50V.D.C. is applied between terminal and terminal(term.A and term.C.term.B and term.C) when shaft is center position.	端子-端子間にて10MΩ以上 Between terminal and terminal: 10MΩ MIN.
4-2 耐電圧 Dielectric strength	端子-軸受間A.C. 300V、1分間又は、A.C. 360V、2分間印加する。(リーク電流1mA) A voltage of 300V.A.C. shall be applied for 1min or a voltage of 360V.A.C. shall be applied for 2s between individual terminals and bushing. (Leak current:1mA)	損傷・アーク・絶縁破壊がないこと。 Without damage to parts, arcing or breakdown.
	端子-端子間(A-C間およびB-C間)にA.C. 50V、1分間又は、A.C. 60V、2分間印加する。(軸がセンター位置にて)(リーク電流1mA) A voltage of 50V.A.C. shall be applied for 1min or a voltage of 60V.A.C. shall be applied for 2s between terminal and terminal(term.A and term.C.term.B and term.C) when shaft is center position. (Leak current:1mA)	損傷・アーク・絶縁破壊がないこと。 Without damage to parts, arcing or breakdown.
4-3 接触抵抗 Contact resistance	時計方向および反時計方向の末端位置にて測定。 Measurement points are full C.W. and full C.C.W. position.	200mΩ以下 MAX.

 <b>ALPS ELECTRIC CO., LTD.</b>				
SYMB	DATE	APPD	CHKD	DSGD
		APPD 1枚-2G '00.6.13 相沢	CHKD 1枚-2G '00.6.13 蒲刈	DSGD 1枚-2G '00.6.13 三浦
TITLE			セルフリターン スイッチ SELF RETURN SWITCH	
DOCUMENT NO.			5P11-7 (1/3)	

CLASS NO.	TITLE セルフリターンSW 規格書 SELF RETURN SWITCH SPECIFICATION	(SW01)
-----------	--	--------

5. 機械的性能 Mechanical characteristics

項目 Item	条件 Conditions	規格 Specifications
5-1 スイッチ回路・接点数 Contact arrangement		単極双投 S. P. D. T.
5-2 全回転角度 Total rotational angle		80° <sup>+10°</sup> -5°
5-3 スイッチ切換トルク Changeover torque		3mN・m~30mN・m
5-4 スイッチ切換角度 Changeover angle	スイッチON範囲 時計方向 : 端子A-C間 ON 反時計方向 : 端子B-C間 ON Switch ON position C. W. direction : Term. A-C is ON. C. C. W. direction: Term. B-C is ON.	軸センターが基準線より 17°±5°~40°±5° 17°±5°~40°±5° From the drawing center line to center of the shaft between 17°±5° and 40°±5° between 17°±5° and 40°±5°
5-5 端子強度 Terminal strength	端子先端の任意の一方に5Nの力を1分間加える。 A static load of 5N be applied to the tip of terminals for 1 min in any direction.	端子の破損、著しい力ゲタがないこと。 但し、端子の曲がり可とする。 Without damage or excessive looseness of terminals. Terminal bend is permitted.
5-6 軸の押し引き強度 Push-pull strength of shaft	軸の押し及び引き方向に100Nの力を10秒間加える。 (セット実装状態) Push and pull static load of 100N shall be applied to the shaft in the axial direction for 10s. (After installing)	軸の破損、著しい力ゲタのないこと。 感触に異常がないこと。 without damage or excessive play in shaft. No excessive abnormality in rotational feeling.
5-7 軸ガタ Shaft wobble	取付面より30mmの位置に50mN・mの曲げモーメントを加える。 軸長が30mmに満たない場合は右の式による。Lは測定位置(取付面からの位置)とする。 Bending moment of 50mN・m to be applied to the shaft at 30mm from the mounting surface. If the shaft length is less than 30mm, the value shall be calculated as right formula. L: Measurement point from mounting surface.	軸受長 軸力ゲタ Bushing Wobble length 以下 (mm) (mmp-p less) 7 0.7xL/30 → 10 0.4xL/30
5-8 軸のスラスト方向ガタ Shaft play in axial direction		0.4mm以下 0.4mm MAX.
5-9 軸の回転方向力ゲタ Rotation play		6°以内 6° MAX.
5-10 軸の回転止め強度 Shaft stopper strength	軸にネジリモーメントを両末端に1秒間加える。 Rotational moment shall be applied to the shaft for 1s. at the both end.	0.5N・m以上 MIN.

**ALPS ELECTRIC CO., LTD.**

初設	2000-06-13	相沢	満洲	三浦	APPD.	CHKD.	OSGD.	TITLE	セルフリターン スイッチ SELF RETURN SWITCH
SYMB	DATE	APPD	CHKD	OSGD	19.10.26 加藤		M-2技 19.10.26 木村	DOCUMENT NO.	5P11-7 (2/3)

CLASS No.		TITLE セルフリターンSW 規格書 SELF RETURN SWITCH SPECIFICATION		(SW01)
	項目 Item	条件 Conditions	規格 Specifications	
5-11	取付以上の注意 Notice for mounting	右図の様ニスイッチ本体を抑えてご使用下さい。セツト側でスイッチ本体の引き及び回転方向の力「イト」が無い場合は、はんだ付けだけの固定となり、はんだ付け信頼性及びスイッチ本体強度が不安定となる可能性があります。 Hold the bushing use front panel or light pipe. Because this switch not has thread. If don't hold the bushing, the switch maybe become Intermittent rough mounting after soldering by knob stopper face.		

6. 耐久性能 Endurance characteristics.

	項目 Item	条件 Conditions	規格 Specifications
6-1	しゅう動寿命性能 Rotational life	軸のセンターを0°とし、時計方向に25°~35°傾けを後、反時計方向に25°~35°傾け、センターに戻した状態を1サイクルとし、毎時800サイクルの速さで15,000サイクル以上行う。 Definition of 1 cycle shaft turned 25°~35° C.W. direction from shaft center, and shaft turned 25°~35° C.C.W. direction from shaft center, and shaft turned center position. The shaft of switch shall be rotated to 15,000 cycles at speed of 800 cycles per hour.	初期規格を満足すること。 Shall be meet initial specifications.

<b>ALPS ELECTRIC CO., LTD.</b>					
SYMB	DATE	APPD	CHKD	DSGD	TITLE セルフリターン スイッチ SELF RETURN SWITCH  DOCUMENT NO. 5P11-7 (3/3)
		APPD. 	CHKD. 	DSGD. 	

CLASS No.	TITLE セルフリターンSW 規格書 SELF RETURN SWITCH SPECIFICATION
-----------	--

1. その他耐久性能 Endurance characteristics.

項目 Item	条 件 Conditions	規 格 Specifications
1-1 高温放置試験 High temperature shelf test	温度85±3°Cの恒温槽中に1,000±10時間放置後、常温、常湿中に1.5時間放置する。 The switch shall be stored at a temperature of 85±3°C for 1,000±10h in a thermostatic chamber. And then the switch shall be subjected to standard atmospheric conditions for 1.5h, after which measurements shall be made.	初期規格を満足すること。 Must meet the initial specifications.
1-2 高温作動試験 High temperature energizing test	定格負荷を加え温度85±3°Cの恒温槽中に1,000±10時間放置後、常温、常湿中に1.5時間放置する。 The rated load shall be applied. The switch shall be stored at a temperature of 85±3°C for 1,000±10h in a thermostatic chamber. And then the switch shall be subjected to standard atmospheric conditions for 1.5h, after which measurements shall be made.	
1-3 低温放置試験 Low temperature shelf test	温度-40±3°Cの恒温槽中に1,000±10時間放置後取り出し表面の水分をふき取り常湿常湿中に1.5時間放置する。 The switch shall be stored at a temperature of -40±3°C for 1,000±10h in a thermostatic chamber. Then the switch shall be taken out of chamber and its surface moisture shall be removed. And then the switch shall be subjected to standard atmospheric conditions for 1.5h, after which measurement shall be made.	
1-4 低温作動(始動)試験 Low temperature energizing test	定格負荷を加え温度-40±3°Cの恒温槽中に1,000±10時間放置後取り出し表面の水分をふき取り常湿常湿中に1.5時間放置する。 The rated load shall be applied. The switch shall be stored at a temperature of -40±3°C for 1,000±10h in a thermostatic chamber. Then the switch shall be taken out of chamber and its surface moisture shall be removed. And then the switch shall be subjected to standard atmospheric conditions for 1.5h, after which measurement shall be made.	
1-5 高温高湿保存試験 High temperature and humidity shelf test	温度60±2°C、湿度90~95%の恒温湿槽中に1,000±10時間放置後、取り出し表面の水分をふき取り常湿常湿中に1.5時間放置後測定する。 The switch shall be stored at a temperature of 60±2°C with relative humidity of 90% to 95% for 1,000±10h in a thermostatic chamber. Then the switch shall be taken out of the chamber and its surface moisture shall be removed. And then the switch shall be subjected to standard atmospheric conditions for 1.5h, after which measurement shall be made.	
1-6 高温高湿通電試験 High temperature and humidity energizing test	定格負荷を加え温度60±2°C、湿度90~95%の恒温湿槽中に1,000±10時間放置後、取り出し表面の水分をふき取り常湿常湿中に1.5時間放置後測定する。 The rated load shall be applied. The switch shall be stored at a temperature of 60±2°C with relative humidity of 90% to 95% for 1,000±10h in a thermostatic chamber. Then the switch shall be taken out of the chamber and its surface moisture shall be removed. And then the switch shall be subjected to standard atmospheric conditions for 1.5h, after which measurement shall be made.	

**ALPS ELECTRIC CO., LTD.**

SYMB	DATE	APPD	CHKD	DSGD	APPD. M-2 10-03-04 加藤	CHKD. M-2 10-03-04 野村	DSGD. M-2 10-03-04 木村	TITLE	DOCUMENT NO. S-E29
------	------	------	------	------	--------------------------------	--------------------------------	--------------------------------	-------	-----------------------

CLASS No.		TITLE										
		セルフリターンSW 規格書 SELF RETURN SWITCH SPECIFICATION										
項目 Item	条件 Conditions	規格 Specifications										
1-7 熱衝撃試験 Heat shock test	<p>下表に示した温度サイクルを連続1000回行う。表面の水分をふき取り常温常湿中に1.5時間放置後測定する。 The switch shall be subjected to 1000 successive change of temperature cycles, each as shown in table below. Then its surface moisture shall be removed. And then the switch shall be subjected to standard atmospheric conditions for 1.5 hour, after which measurements shall be made.</p> <table border="1"> <thead> <tr> <th>段階 Step</th> <th>温度 Temperature</th> <th>時間 Time</th> </tr> </thead> <tbody> <tr> <td>1</td> <td>-40±3℃</td> <td>30min.</td> </tr> <tr> <td>2</td> <td>85±2℃</td> <td>30min.</td> </tr> </tbody> </table>	段階 Step	温度 Temperature	時間 Time	1	-40±3℃	30min.	2	85±2℃	30min.	初期規格を満足すること。 Must meet the initial specifications.	
段階 Step	温度 Temperature	時間 Time										
1	-40±3℃	30min.										
2	85±2℃	30min.										
1-8 振動試験 Vibration test	<p>周波数 : 10Hz~500Hz~10Hz Frequency range 最大加速度 : 49.1m/s<sup>2</sup>(5G) The maximum acceetation X, Y, Z各方向8時間行う(計24時間) This motion shall be applied for a period of 8h in each of 3 mutually perpendicular axes. (A total of 24h)</p>											
1-9 ワイスカ試験 Whisker test	<p>条件1 Condition1 常温常湿で3000時間放置する。 The switch shall be subjected to standard atmospheric conditions for 3000h.</p> <p>条件2 Condition2 温度85℃、湿度85%RHの恒温槽中に2000±10時間放置後取り出し常温常湿に1.5時間放置する。 The switch shall be stored at a temperature of 85℃ with relative humidity of 85% for 2,000±10h in a thermostatic chamber. And then the switch shall be subjected to standard atmospheric conditions for 1.5h, after which measurement shall be made.</p> <p>条件3 Condition3 下記に示した温度サイクルを連続1000回行う。 The switch shall be subjected to 1000 successive change of temperature cycles, each as shown in table below.</p> <table border="1"> <thead> <tr> <th>段階 Step</th> <th>温度 Temperature</th> <th>時間 Time</th> </tr> </thead> <tbody> <tr> <td>1</td> <td>-40±3℃</td> <td>30min.</td> </tr> <tr> <td>2</td> <td>85±2℃</td> <td>30min.</td> </tr> </tbody> </table>	段階 Step	温度 Temperature	時間 Time	1	-40±3℃	30min.	2	85±2℃	30min.	端子上のワイスカは、最小電極間隔の1/2未満、または、長さ50μm以下。 The whisker on the terminal is less than 1/2 at minimum electrode intervals or length 50μm or less.	
段階 Step	温度 Temperature	時間 Time										
1	-40±3℃	30min.										
2	85±2℃	30min.										

					<b>ALPS ELECTRIC CO., LTD.</b>				
					APPD.	CHKD.	DSGD.	TITLE	
					M-2技 10-03-04	M-2技 10-03-04	M-2技 10-03-04	DOCUMENT NO.	
					加 藤	野 村	木 村	S - E 2 9 (2/3)	
SYMB	DATE	APPD	CHKD	DSGD					

CLASS No.	TITLE セルフリターンSW 規格書 SELF RETURN SWITCH SPECIFICATION	
-----------	--	--

項目 Item	条件 Conditions	規格 Specifications
1-10 端子強度 Terminal strength	<p>引っ張り強度 Pull strenght</p> <p>端子の引き出し軸が垂直になるように保持し、どのような衝撃も加えないように徐々に2.5Nの力を加え10±1秒間保持する。 The trial offer is maintained so that the drawing out axis of the terminal may become vertical. The power of gradually 2.5N is added so as not to add the impact, and the power is maintained for 10±1s.</p> <hr/> <p>曲げ試験 Bending test</p> <p>端子の引き出し軸が垂直になるように保持し、端子先端に1.25Nのおもりをつり下げ、本体を90°曲げた後、元の位置に戻す。操作は2~3秒間で行い、これを1回とする。次に逆方向に同じ速さで90°曲げ、再び元の位置に戻す。 After the trial is maintained so that the drawing out axis of the terminal may become vertical, the harpoon 1.25N is hung on the point of the terminal, and the main body is bent by 90°, it returns it to former position. The operation makes this do in 2-3 seconds once. next, 90° in the same speed as the opposite direction is bent, and returns it to former position again.</p> <hr/> <p>ねじり試験 Twist test</p> <p>端子を90°折り曲げて固定し、スイッチ本体を5秒間で360°回転させる。交互回転方向を1セットとし、2回行なう。 The terminal is bent to 90 degrees it fixes, and the switch body is rotated by 360 degrees every five seconds. 360 degrees are made to be rotated by one round trip 1 time, and it dose 2 times.</p>	<p>初期規格を満足し、外観及び構造に異常が無い事。 Meet an initial standard, and do not find abnormality in externals and the structure. The transformation of the terminal is excluded.</p>
1-11 ガス腐食試験 Gaseous corrosion test	<p>無負荷で、H<sub>2</sub>S濃度10ppm、温度40±2°C、湿度80%RHの槽中に240時間設置する。 The switch shall be stored at a H<sub>2</sub>S density of 10ppm, with temperature of 40±2 C, relative humidity of 80% RH for 240 hours in a thermostatic chamber without load.</p>	<p>接触抵抗：初期規格値の2倍以下 Contact resistance: twice or less initial specification.</p>

<b>ALPS ELECTRIC CO., LTD.</b>					
SYMB	DATE	APPD	CHKD	DSGD	TITLE
		APPD. M-2 掛 10-03-04 加藤	CHKD. M-2 掛 10-03-04 野村	DSGD. M-2 掛 10-03-04 末村	DOCUMENT NO.
					S - E 2 9 (3/3)

CLASS NO.	TITLE
-----------	-------

1. はんだ試験 Soldering examination.

項目 Item	条件 Conditions	規格 Specifications									
1-1 はんだ耐熱性試験 Soldering heatproof.	<p>条件1 Condition 1</p> <p>予リヒート : 基板表面温度100~140℃, 時間40秒以内 Preheating: -Surface temperature of board: 100 to 140℃ -Preheating time: Within 40s.</p> <p>はんだ温度: 265℃以下 Solder temperature: 265℃ or less.</p> <p>浸漬時間: 10秒以内 Dipping time of soldering: Within 10s.</p> <hr/> <p>条件2 Condition 2</p> <p>こて先温度: 390℃以下 Bit temperature of soldering iron: 390℃ or less.</p> <p>加熱時間: 3秒以内 Application time of soldering iron: Within 3s.</p> <p>加熱回数: 2回 Maximum frequency of soldering: 2 time</p>	<p>初期規格を満足すること。 Must meet the Initial specifications.</p>									
1-2 はんだ付け性試験 Soldering bill.	<p>条件1 Condition 1</p> <p>溶融温度 : 250±2℃ Temperature of soldering.</p> <p>フラックス : W/Wロジン Flux : W/W rosin</p> <p>はんだ : Sn-3.0Ag-0.5Cu Solder</p> <p>上記の条件のハンダ槍にフラックスを塗布した端子先端を浸漬する。(浸漬深さ:2~5mm, 浸漬速度:20±5mm/s.) The terminal point which spreads the flux on the solder tank is soaked. (terminal point:2~5mm, time:20±5mm/s.)</p> <hr/> <p>条件2 Condition 2</p> <p>予リヒート : 基板表面温度100~140℃, 時間40秒以内 Preheating: -Surface temperature of board: 100 to 140℃ -Preheating time: Within 40s.</p> <p>△ はんだ温度 : 250℃±2℃ Solder temoerature: 250℃±2℃</p> <p>△ 浸漬時間 : 3秒以内 Dipping time of soldering: Within 3s.</p> <p>フラックス : 947化成(株)製CF-110VH-2A, 及び同等品 Flux : TAMURA KAKEN CORPORATION : CF-110VH-2A or the equal article</p> <p>はんだ : Sn-3.0Ag-0.5Cu Solder</p>	<p>浸漬面の95%以上がはんだで覆われていること。 95% or more on the dipping side must be covered with solder.</p>									
1-3 △ 電気接合寿命試験 Electrical joint life test by soldering	<p>下記示した温度サイクルを連続1,000サイクル行なう。 The switch shall be subjected to 1,000 successive change of temperature cycles.</p> <table border="1"> <thead> <tr> <th>段階 Step</th> <th>温度 Temperature</th> <th>時間 Time</th> </tr> </thead> <tbody> <tr> <td>1</td> <td>-40±3℃</td> <td>30min.</td> </tr> <tr> <td>2</td> <td>+85±3℃</td> <td>30min.</td> </tr> </tbody> </table>	段階 Step	温度 Temperature	時間 Time	1	-40±3℃	30min.	2	+85±3℃	30min.	<p>半田固着強度は、初期値の50%以上あること。 Solder clinging strength: Relative to the previously specified value. 50% or more.</p>
段階 Step	温度 Temperature	時間 Time									
1	-40±3℃	30min.									
2	+85±3℃	30min.									

**ALPS ELECTRIC CO., LTD.**

APPD.	CHKD.	DSGD.	TITLE
△ 1 2010-04-27 Y. K A. N H. K	M-2技	M-2技	
△ 2 2010-04-06 Y. K A. N M. C	10-03-04	10-03-04	
ORG 2010-03-04 Y. K A. N H. K	加藤	野村	木村
SYMB	DATE	APPD	CHKO
			DSGD
DOCUMENT NO.			L-E50 (1/1)

注記 軸受材質：亜鉛ダイキャスト  
軸材質：黄銅

(SW01) SELF RETURN

NOTES BUSHING MATERIAL: ZINC ALLOY DIE CASTING  
SHAFT MATERIAL: BRASS

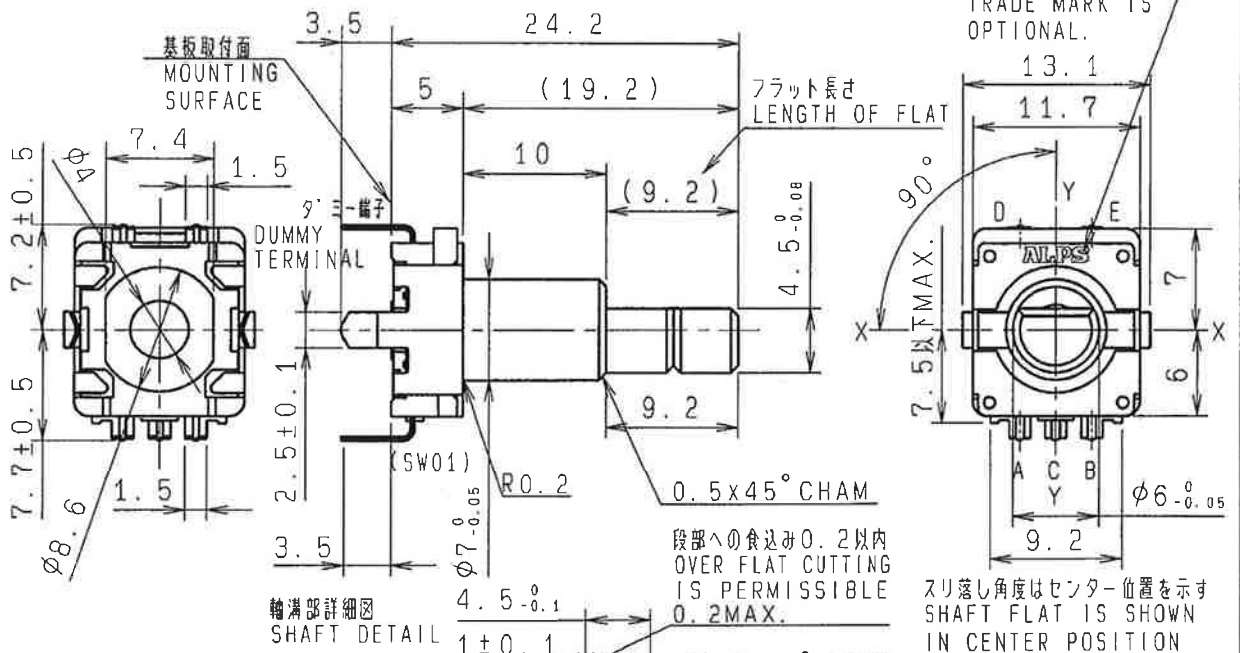

軸挿入部端子形状詳細 (3:1)  
TERMINAL DETAIL

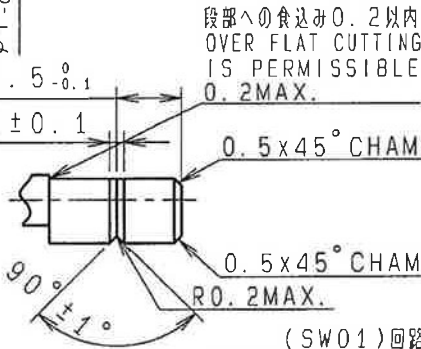

取付穴寸法図 許容差±0.1  
(部品挿入側)  
P.W.B. MOUNTING DETAIL  
TOLERANCE±0.1  
VIEWED FROM MOUNTING SIDE

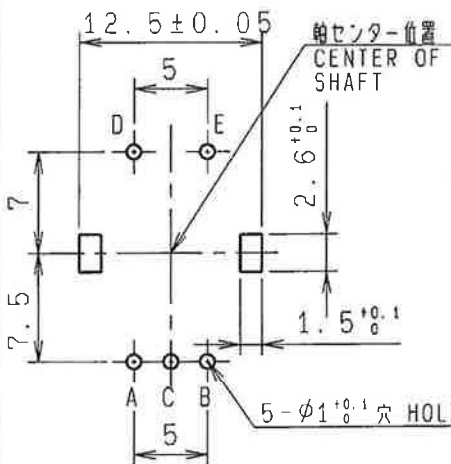

基板厚 t=1.6mm  
P.C.B. THICKNESS t=1.6mm

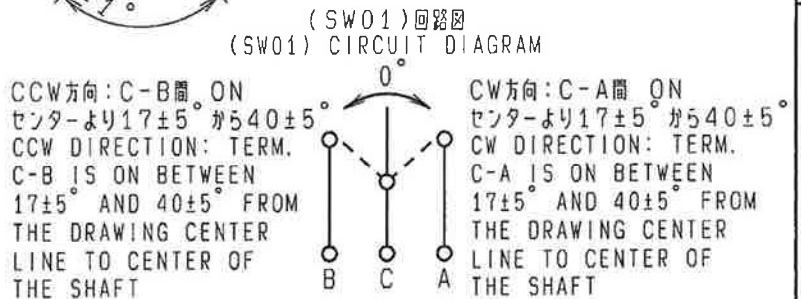

(SW01) 回路図 (SW01) CIRCUIT DIAGRAM



指定なき部分の許容差 TOLERANCES UNLESS OTHERWISE SPEC	
$L \leq 10$	±0.3
$10 < L \leq 100$	±0.5
$100 \leq L$	±0.8
角度 ANGULAR DIMENSION	±5°

PART NO.	MATERIAL	SPEC/NAME	FINISH

# ALPS ELECTRIC CO., LTD.

NO.	SYMB	DATE	APPD	CHKD	DSGD	Y. KATO	2009-12-24	SCALE	NO.	TITLE	DOCUMENT NO.
								2:1		11形1軸セルフリターン組立図	P11H11237



## X-ON Electronics

Largest Supplier of Electrical and Electronic Components

*Click to view similar products for [Coded Rotary Switches](#) category:*

*Click to view products by [ALPS](#) manufacturer:*

Other Similar products are found below :

[PT65503RT](#) [P60A703](#) [RTAP31S12WFLSP](#) [GSER-10](#) [GT-EVA01AA-L1](#) [EC11L1525G01](#) [EC111012000Y](#) [EC28B1550404](#) [EC11E0940501](#)  
[CRD10CM0SBR](#) [DRS4116](#) [RTE1600R44](#) [ERD110RSZ](#) [ERD116CSZ](#) [ERD116RFZ](#) [ERD116RSZ](#) [94HCB10T](#) [94HBB16WT](#) [94HBB16RAT](#)  
[94HBB10WT](#) [94HBB10RAT](#) [94HBB08RAT](#) [94HAC10T](#) [94HAB16WT](#) [94HAB16T](#) [94HAB10WT](#) [94HAB10RAT](#) [94HAB08WT](#)  
[94HAB08RAT](#) [ERD216RSZ](#) [P65SMT101](#) [P65SMT103](#) [P65THR703L254](#) [ND3FR10P](#) [DRR3110](#) [S-4010TA](#) [94HCB16WT](#) [94HCB16T](#)  
[94HCB10RAT](#) [94HCB08T](#) [94HBB16T](#) [94HBB10T](#) [94HBB08T](#) [94HAB16RAT](#) [94HAB10T](#) [94HAB08T](#) [S-2050](#) [S-2031A](#) [S-2011A](#) [S-1030A](#)