

CLASS No.	TITLE 回転形エンコーダ 規格書 ROTATIONAL ENCODER SPECIFICATION	EC11J0925501 (SW01)
-----------	---	------------------------

1. 一般事項 General

1-1 適用範囲 Scope

この仕様書は主として電子機器に用いる微小電流回路用11形薄形ロータリーエンコーダに適用する。
This specification applies to 11mm size low-profile rotary encoder (incremental type) for microscopic current circuits, used in electronic equipment.

1-2 標準状態 Standard atmospheric conditions

測定は特に指定のない限り、次の状態で行なう。
Unless otherwise specified, the standard range of atmospheric conditions for making measurements and tests is as follows:

温度 Ambient temperature : 15°C to 35°C
 相対湿度 Relative humidity : 25% to 85%
 気圧 Air pressure : 86kPa to 106kPa

但し、疑義を生じた場合は、次の基準状態で行なう。

If there is any doubt about the results, measurements shall be made within the following limits:

温度 Ambient temperature : 20 ± 1°C
 相対湿度 Relative humidity : 63% to 67%
 気圧 Air pressure : 86kPa to 106kPa

1-3 使用温度範囲

Operating temperature range : -40°C to +85°C

1-4 保存温度範囲

Storage temperature range : -40°C to +85°C

2. 構造 Construction

2-1 寸法 Dimensions

添付組立図による。
Refer to attached drawing.

3. 定格 Rating

3-1 定格容量 Rating : D.C. 5V 10mA (1mA MIN)

4. 電気的性能 Electrical characteristics

項目 Item	条件 Conditions	規格 Specifications													
4-1 出力信号 Output signal format	注意事項：1パルス出力は2クリックで1パルス出力となっております。又、クリック位置にてA-C端子出力がON、又はOFFとなっております、B-C端子出力のクリック位置での規定はしてありません。 Note: Output signal is 1 pulse per 2 detents. And terminal A-C is pulse ON or OFF at detent position. No specified output of terminal B-C at detent position. <Fig 1>	A, B 2信号の位相差出力とし、詳細は<Fig. 1>の通りとする。 (破線はクリックの位置を示す。) 2 Phase-different signals (Signal A, signal B) Details shown in <Fig. 1>. (The broken line shows detent position.)													
	<table border="1"> <thead> <tr> <th>軸回転方向 Shaft rotational direction</th> <th>信号 Signal</th> <th>出力波形 Output</th> </tr> </thead> <tbody> <tr> <td rowspan="2">時計方向 C. W.</td> <td>A (A-C端子間) A(Terminal A-C)</td> <td>OFF ON </td> </tr> <tr> <td>B (B-C端子間) B(Terminal B-C)</td> <td>OFF ON </td> </tr> <tr> <td rowspan="2">反時計方向 C. C. W.</td> <td>A (A-C端子間) A(Terminal A-C)</td> <td>OFF ON </td> </tr> <tr> <td>B (B-C端子間) B(Terminal B-C)</td> <td>OFF ON </td> </tr> </tbody> </table>	軸回転方向 Shaft rotational direction	信号 Signal	出力波形 Output	時計方向 C. W.	A (A-C端子間) A(Terminal A-C)	OFF ON	B (B-C端子間) B(Terminal B-C)	OFF ON	反時計方向 C. C. W.	A (A-C端子間) A(Terminal A-C)	OFF ON	B (B-C端子間) B(Terminal B-C)	OFF ON	
軸回転方向 Shaft rotational direction	信号 Signal	出力波形 Output													
時計方向 C. W.	A (A-C端子間) A(Terminal A-C)	OFF ON													
	B (B-C端子間) B(Terminal B-C)	OFF ON													
反時計方向 C. C. W.	A (A-C端子間) A(Terminal A-C)	OFF ON													
	B (B-C端子間) B(Terminal B-C)	OFF ON													

ALPS ELECTRIC CO., LTD.

APPD.	CHKD.	DSGD.	TITLE
M-DSG2	M-DSG2	M-DSG2	回転形エンコーダ ROTATIONAL ENCODER
S. WIZOBUCHI	A. NOMURA	H. MIURA	DOCUMENT NO.
2010/12/01	2010/12/01	2010/12/01	5 L A 2 1 1 - J 2 3 (1/5)

SYMB	DATE	APPD	CHKD	DSGD
------	------	------	------	------

項目 Item	条件 Conditions	規格 Specifications
4-2 分解能 Resolution	1回転にて出力されるパルス数 Number of pulses in 360° rotation.	各相 9パルス/360° 9 pulses/360° for each phase (2クリック 1パルス) (2 click 1 pulse)
4-3 スイッチング特性 Switching characteristics	<p>下記測定回路<fig. 2>を用い、回転軸を$360^{\circ} \cdot s^{-1}$の速さで回転し測定する。 Measurement shall be made under the condition as follows.</p> <p>1) Shaft rotational speed : $360^{\circ} \cdot s^{-1}$ 2) Test circuit : <fig. 2></p> <div style="text-align: center;"> <p><fig. 2></p> </div> <div style="text-align: right;"> <p><fig. 3></p> </div> <p>(注記) コードOFF状態 : 出力電圧が$2.5V$以上の状態を言う。 コードON状態 : 出力電圧が$2.5V$以下の状態を言う。 (note) Code-OFF area : The area which the voltage is $2.5V$ or more. code-ON area : The area which the voltage is $2.5V$ or less.</p>	
1) チャタリング Chattering	コードのOFF→ON及びON→OFFの際の、出力 $2.5V$ の通過時間にて規定する。 Specified by the signal's passage time from $2.5V$ or from $2.5V$ of each switching position (code OFF→ON or ON→OFF).	$t_1, t_3 \leq 3ms$
2) 摺動ノイズ (バウンス) Sliding noise (Bounce)	コードONの部分の $2.5V$ 以上の電圧変動時間とし、チャタリング t_1, t_3 両者との間に $1ms$ 以上の $2.5V$ 以下のON部分を有するものとする。また、摺動ノイズ間に $2.5V$ 以下の範囲が $1ms$ 以上ある場合は、別の摺動ノイズと判断する。 Specified by the time of voltage change exceed $2.5V$ in code-ON area. When the bounce has code-ON time less than $1ms$ between chatterings (t_1 or t_3), the voltage change shall be regarded as a part of chattering. When the code-ON time between 2 bounces is less than $1ms$, they are regarded as 1 linked bounce.	$t_2 \leq 2ms$
3) 摺動ノイズ Sliding noise	コードOFFの部分の電圧変動 The voltage change in code-OFF area.	$2.5V$ 以上 $2.5V$ MIN

CLASS No.	TITLE 回転形エンコーダ 規格書 ROTATIONALENCODER SPECIFICATION	(SW01)
-----------	--	--------

項目 Item	条件 Conditions	規格 Specifications
4-4 位相差 Phase-difference	<p>$360^\circ \cdot s^{-1}$の定速にて操作軸を回転する。 Measurement shall be made under the condition which the shaft is rotated in $360^\circ \cdot s^{-1}$ (constant speed).</p> <p><Fig. 4></p> <p>A信号 (A-C間) Signal A</p> <p>B信号 (B-C間) Signal B</p> <p>OFF ON OFF ON</p> <p>注意事項：摺動接点ですので手動操作時の出力波形はご使用されるツマミ径、軸の回転速度によって変化致します。回路設計時は実装にて確認願います。 Note: Above specification (4-4) is changeable. When operate by manual. Please check performance using actual circuit and knob.</p>	<p><Fig. 4>において $T_1, T_2, T_3, T_4 \geq 4ms$ In <Fig. 4></p>
4-5 絶縁抵抗 Insulation resistance	<p>端子-軸受間にD. C. 250V印加する。 Measurement shall be made under the condition which a voltage of 250VD.C. is applied between individual terminals and bushing.</p>	<p>端子-軸受間にて100MΩ以上 Between individual terminals and bushing: 100MΩ MIN.</p>
4-6 耐電圧 Dielectric strength	<p>端子-軸受間にA. C. 300V1分間又は、A. C. 360V1秒間印加する。 (リーク電流1mA) A voltage of 300VA.C. shall be applied for 1min or a voltage of 360VA.C. shall be applied for 1s between individual terminals and bushing. (Leak current:1mA)</p>	<p>損傷・アーク・絶縁破壊がないこと。 Without damage to parts, arcing or breakdown.</p>

5. 機械的性能 Mechanical characteristics

項目 Item	条件 Conditions	規格 Specifications
5-1 全回転角度 Total rotational angle		<p>360° (エンドレス) 360° (Endless)</p>
5-2 クリックトルク Detent torque		<p>初期: $12 \pm 5mN \cdot m$ Initial: $12 \pm 5mN \cdot m$ リフロー後: $10 \pm 4mN \cdot m$ After reflow: $10 \pm 4mN \cdot m$</p>
5-3 クリック点数及び位置 Number and position of detents.		<p>18点クリック 18 detents (ステップ角度 $20^\circ \pm 3^\circ$) (Step angle: $20^\circ \pm 3^\circ$)</p>

					ALPS ELECTRIC CO., LTD.					
					APPD.	CHKD.	DSGD.	TITLE		
					M-DSG2	M-DSG2	M-DSG2	回転形エンコーダ ROTATIONALENCODER		
					S. MIZOBUCHI	A. NOMURA	H. MIURA	DOCUMENT NO.		
SYMB	DATE	APPD	CHKD	DSGD	2010/12/01	2010/12/01	2010/12/01	5LA211-J23 (3/5)		

CLASS No.	TITLE 回転形エンコーダ 規格書 ROTATIONAL ENCODER SPECIFICATION	(SW01)
-----------	---	--------

項目 Item	条件 Conditions	規格 Specifications
5-5 軸の押し引き強度 Push-pull strength of shaft	軸の押し方向に150N、引き方向に100Nの力を10秒間加える。 (セット実装状態) Push static load of 150N and Pull static load of 100N shall be applied to the shaft in the axial direction for 10s. (After installing)	軸の破損、著しいガタのないこと。 感触に異常がないこと。 Without damage or excessive play in shaft. No excessive abnormality in rotational feeling.
5-6 軸ガタ Shaft wobble	取付面より20mmの位置に50mN・mの曲げモーメントを加える。 軸長が20mmに満たない場合は右の式による。Lは測定位置(取付面からの位置)とする。 Bending moment of 50mN・m to be applied to the shaft at 20mm from the mounting surface. If the shaft length is less than 20mm, the value shall be calculated as right formula. L: Measurement point from mounting surface.	軸受長 軸力タ Bushings Wobble length 以下 (mm) (mmp-p less) 5 0.3 xL/20 7 0.25xL/20 ➔ 10 0.2 xL/20
5-7 軸のスラスト方向ガタ Shaft play in axial direction		0.2mm以下 0.2mm MAX.
5-8 軸の回転方向ガタ Rotation play at the click position	角度板にて測定する。 Measure with jig for rotational angle.	3°以内 3° MAX.
5-9 取付け上の注意 Notice for mounting	右図の様にスイッチ本体を抑えてご使用下さい。セット側でスイッチ本体の引き及び回転方向のガタが無い場合は、はんだ付けだけの固定となり、はんだ付け信頼性及びスイッチ本体強度が不安定となる可能性があります。 Hold the bushing use front panel or light pipe. Because this switch not has thread. If don't hold the bushing, the switch maybe become intermittent rough mounting after soldering by knob stopper face.	

6. 耐久性能 Endurance characteristics.

項目 Item	条件 Conditions	規格 Specifications
6-1 しゅう動寿命性能 Rotational life	無負荷で軸を毎時1,000サイクルの速まで、100,000サイクル連続動作を行う。 但し、試験途中50,000で中間測定を行う。(1サイクルは、360°1往復) The shaft of encoder shall be rotated to 100,000 cycles at a speed of 1,000cycles per hour without electrical load, after which measurements shall be made. However, an interim measurement shall be made immediately after 50,000 cycles. (1 cycle: rotate 360° CCW rotate 360° CW)	クリックトルク 初期規格値に対し ^{+0%} _{-70%} チャタリング: 5ms以下 摺動ノイズ(バウンス): 3ms以下 その他、初期規格を満足すること。 Detent torque: Relative to the previously specified value. ^{+0%} _{-70%} Chattering: 5ms MAX. Sliding noise: 3ms MAX. (Bounce) Except above items, specifications in clause 4.1~6 and 5.1, 5.3 shall be satisfied.

					ALPS ELECTRIC CO., LTD.				
		APPD.	CHKD.	DSGD.	TITLE 回転形エンコーダ ROTATIONAL ENCODER				
		M-DSG2	M-DSG2	M-DSG2					
		S. WIZOBUCHI	A. NOMURA	H. MIURA	DOCUMENT NO.				
		2010/12/01	2010/12/01	2010/12/01	5LA211-J23 (4/5)				
SYMB	DATE	APPD	CHKD	DSGD					

CLASS No.

TITLE

回転形エンコーダ 規格書
ROTATIONAL ENCODER SPECIFICATION

(SW01)

7. その他、取扱い上の注意 Precautions in use

- 7-1 エンコーダのパルスカウント処理の設計においては動作スピード、サンプリングタイム、マスキングタイム等に注意し、実装確認を上御使用願います。
In case of pulse count process design, operational speed, sampling time, and masking time etc should be taken into the consideration.
Please check above matter at first on your circuit for the secure reason.
- 7-2 本製品はクリック位置にてA相はON又はOFF位置にて安定となりますので、ソフト設計時A相基準で設計願います。
A phase should be design criterion prior to B phase.
Because A phase has steady on signal or off signal at detent position.
- 7-3 エンコーダのパルスカウント処理の回路は下図のフィルターを入れることを推奨します。
For your pulse count design, it should be considered to add C/R filter on your circuit shown as below.

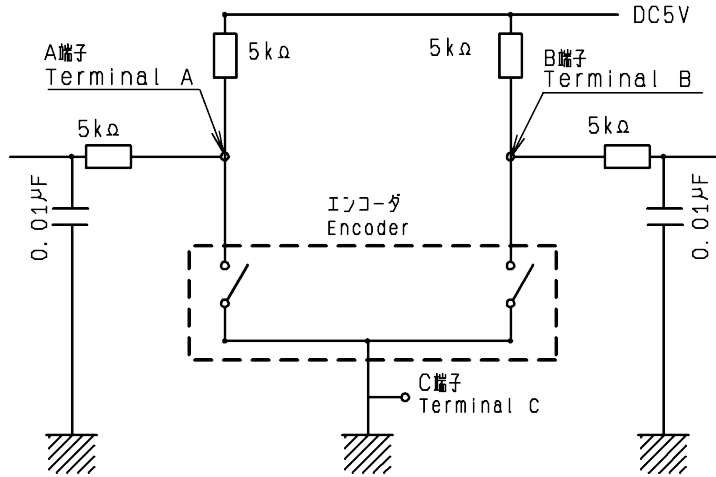

- 7-4 エンコーダの回路処理は、下図の読取方法を推奨します。
For your pulse count, it should be considered below method.

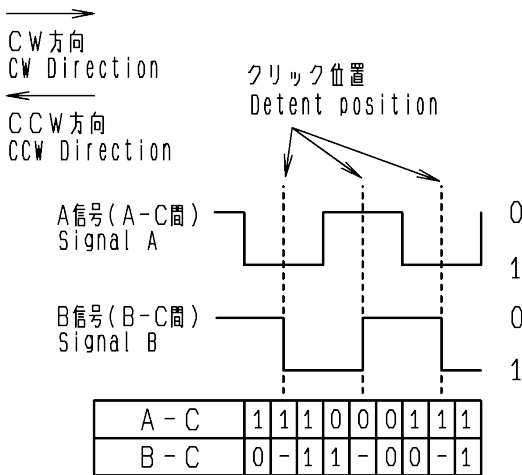

A相の状態が変化した時にカウントし、CW、CCWの判定はその時のB相の状態による。
Output is counted on phase A changing, adjudication of phase B or CCW depends on conditions of phase B at each time.

	CW方向	CCW方向
A相	0 → 1	0 → 1
B相	0	1
A相	1 → 0	1 → 0
B相	1	0

A相が0→1に変化した時に、B相が0であればCW方向、また、B相が1であればCCW方向である。
On phase A changing 0 to 1, phase B is 0 means CW direction, phase B is 1 means CCW direction.

A相が1→0に変化した時に、B相が1であればCW方向、また、B相が0であればCCW方向である。
On phase A changing 1 to 0, phase B is 1 means CW direction, phase B is 0 means CCW direction.

ALPS ELECTRIC CO., LTD.

APPD.	CHKD.	DSGD.	TITLE
M-DSG2	M-DSG2	M-DSG2	回転形エンコーダ ROTATIONAL ENCODER
S. MIZOBUCHI	A. NOMURA	H. MIURA	DOCUMENT NO.
2010/12/01	2010/12/01	2010/12/01	5LA211-J23 (5/5)
SYMB	DATE	APPD	CHKD
			DSGD

CLASS NO.	TITLE プッシュモーメンタリスイッチ規格書 PUSH MOMENTARY SWITCH SPECIFICATION	(SW02)
-----------	---	--------

1. 定格容量 (抵抗負荷)
Switch rating (Resistor load) D.C. 5V 0.1A (0.1mA MIN)
2. 電気的性能 Electrical characteristics

項目 Item	条件 Conditions	規格 Specifications
2-1 接触抵抗 Contact resistance	D. C. 5V0.1mA電圧降下法にて測定する。 Measured by the 0.1mA 5V D.C. voltage drop method.	100mΩ MAX.
2-2 チャタリング Chattering	1サイクル (OFF-ON-OFF) 1秒で動作させる。 Switch is operated at the rate of 1 cycle 1s. The 1 cycle shall be OFF-ON-OFF.	10ms以下 Less than 10ms
2-3 絶縁抵抗 Insulation resistance	端子-軸受間にD. C. 250V印加する。 Measurement shall be made under the condition which a voltage of 250VD.C. is applied between individual terminals and bushing.	端子-軸受間にて100MΩ以上 Between individual terminals and bushing: 100MΩ MIN.
2-4 耐電圧 Dielectric strength	端子-軸受間にA. C. 300V1分間又は、A. C. 360V1秒間印加する。 (リーク電流1mA) A voltage of 300VA.C. shall be applied for 1min or a voltage of 360VA.C. shall be applied for 1s between individual terminals and bushing. (Leak current:1mA)	損傷・アーク・絶縁破壊がないこと。 Without damage to parts, arcing or breakdown.

注記:
Note: 軸・スイッチ端子間は絶縁されております。
Shaft is insulated from switch terminal.

3. 機械的性能 Mechanical characteristics

項目 Item	条件 Conditions	規格 Specifications
3-1 スイッチ回路・接点数 Contact arrangement		単極単投 (Push on) S. P. S. T. (Push on)
3-2 スイッチ移動量 Switching stroke		1.5±0.5mm
3-3 スイッチ作動力 Switch operation force		4.7±1.5N

4. 耐久性能 Endurance characteristics.

項目 Item	条件 Conditions	規格 Specifications
4-1 動作寿命特性 Operating life	無負荷にて軸を毎時1000回の速さで100,000回連続動作を行う。 但し、試験途中50,000で中間測定を行う。押し圧:10N以下 The shaft of switch shall be 100,000 times at a speed of 1000times per hour without electrical load, after which measurements shall be made. However, an interim measurement shall be made immediately after 50,000 times. Push force:10N MAX.	接触抵抗:200mΩ以下 スイッチ作動力:4.7 ^{+1.5} _{-2.5} N その他、初期規格を満足すること。 Switch contact resistance:200mΩMAX. Switch operation force: 4.7 ^{+1.5} _{-2.5} N Except above items, specifications in clause 2.2~4, and 3.1~2 shall be satisfied.

5. その他 Note

- 5-1 軸にツマミを取り付け、センターから10mmの位置で押しした時にひっかかり感が無いこと。
No sticky feel shall be observed when the knob on the shaft is pushed at 10mm off the center.

6. 注意事項 Note

- 6-1 プッシュスイッチ付きのエンコーダは、軸が押されたままの状態に梱包や保管をされますと、スイッチ部に支障をまきたす恐れがありますのでご注意ください。
Encoder equipped with a push-on switches are packaged or stored with their shafts being pushed-in, the switch part may be out of order and pay attention when you package or store them.

					ALPS ELECTRIC CO., LTD.				
					APPD.	CHKD.	DSGD.	TITLE	
					M-DSG2	M-DSG2	M-DSG2	プッシュモーメンタリスイッチ PUSH MOMENTARY SWITCH	
					S. MIZOBUCHI	A. NOMURA	H. MIURA	DOCUMENT NO.	
SYMB	DATE	APPD	CHKD	DSGD	2010/12/01	2010/12/01	2010/12/01	5LA2115-J4 (1/1)	

CLASS No.	TITLE エンコータ・フッシュモーメンタリSW規格書 ENCODER・PUSH MOMENTARY SWITCH SPECIFICATION	(SW01)(SW02)
-----------	--	--------------

1. その他耐久性能 Endurance characteristics.

項目 Item	条件 Conditions	規格 Specifications
1-1 耐熱性 Dry heat	無負荷で温度85±2℃の恒温槽中に240±8時間放置する。 測定は標準状態に1~2時間放置後行う。 The encoder shall be exposed at 85±2°C without electrical load for 240±8h. Then the encoder shall be maintained at standard atmospheric conditions for 1 through 2 h. After which measurements shall be made.	(SW02) 接触抵抗: 200mΩ以下 クリックトルクははんだ付け後 その他、初期規格を満足すること。 (SW02) Switch contact resistance: 200mΩMAX. Must meet after soldered specification for detent torque. Must meet or exceed the initial specifications for other items.
1-2 耐寒性 Cold	無負荷で温度-40±2℃の恒温槽中に240±8時間放置する。 測定は表面の水分をふき取り、標準状態に1~2時間放置後行う。 The encoder shall be exposed at -40±2°C without electrical load for 240±8h. Then the encoder shall be taken out of the chamber and its surface moisture shall be removed. Then the encoder shall be maintained at standard atmospheric conditions for 1 through 2 h. After which measurements shall be made.	(SW02) 接触抵抗: 200mΩ以下 クリックトルクははんだ付け後 その他、初期規格を満足すること。 (SW02) Switch contact resistance: 200mΩMAX. Must meet after soldered specification for detent torque. Must meet or exceed the initial specifications for other items.
1-3 耐湿性 Damp heat	無負荷で温度60±2℃、湿度90~95%RHの恒温恒湿槽中に240±8時間放置する。 測定は表面の水分をふき取り、標準状態に1~2時間放置後行う。 The encoder shall be exposed at 60±2°C, 90~95%RH without electrical load for 240±8h. Then the encoder shall be taken out of the chamber and its surface moisture shall be removed. Then the encoder shall be maintained at standard atmospheric conditions for 1 through 2h. After which measurements shall be made.	(SW02) 接触抵抗: 200mΩ以下 クリックトルクははんだ付け後 その他、初期規格を満足すること。 (SW02) Switch contact resistance: 200mΩMAX. Must meet after soldered specification for detent torque. Must meet or exceed the initial specifications for other items.
1-4 温度サイクル Temperature cycle	無負荷で85±2℃30分、-40±3℃30分を1サイクルとし、100サイクル行う。 測定は表面の水分をふき取り、標準状態に1~2時間放置後行う。 The encoder shall be subjected to 100 successive change of temperature cycles without electrical load, each cycle at 85±2°C 30min./-45±3°C 30min.. Then the encoder shall be taken out of the chamber and its surface moisture shall be removed. Then the encoder shall be maintained at standard atmospheric conditions for 1 through 2h. After which measurements shall be made.	(SW02) 接触抵抗: 200mΩ以下 クリックトルクははんだ付け後 その他、初期規格を満足すること。 (SW02) Switch contact resistance: 200mΩMAX. Must meet after soldered specification for detent torque. Must meet or exceed the initial specifications for other items.
1-5 耐振性 Vibration	掃引の割合: 10~55~10HZ, 1分間で直線的に掃引、全振幅1.5mm, 正弦波 X, Y, Z方向に各2時間、計6時間。 その他はJIS C 0040に準拠する。 Frequency range: 10~55~10Hz, 1min. linearly. Amplitude: 1.5mm, sine wave. This motion shall be applied for a period of 2 hours in each of three mutually perpendicular directions for a total of 6 h. For other procedures, refer to IEC Pub. 68-2-6	クリックトルクははんだ付け後 その他、初期規格を満足すること。 Must meet after soldered specification for detent torque. Must meet or exceed the initial specifications for other items.

					ALPS ELECTRIC CO., LTD.			
					APPD.	CHKD.	DSGD.	TITLE エンコータ・フッシュモーメンタリSW
					M-DSG2	M-DSG2	M-DSG2	ENCODER・PUSH MOMENTARY SWITCH
					S. MIZOBUCHI	A. NOMURA	H. MIURA	DOCUMENT NO.
SYMB	DATE	APPD	CHKD	DSGD	2010/12/28	2010/12/28	2010/12/28	S-J6 (1/2)

CLASS No. _____	TITLE エンコータ・フッシュモーメンタリSW規格書 ENCODER・PUSH MOMENTARY SWITCH SPECIFICATION	(SW01)(SW02)
--------------------	--	--------------

項目 Item	条件 Conditions	規格 Specifications
1-6 耐硫化性 Resistance to sulfuration	温度：40℃、湿度：70~75%RH、硫化水素濃度：1ppm、放置時間：96±8時間 Temperature : 40℃ Humidity : 70~75%RH Hydrogen sulfide : 1ppm. Time : 96±8h	(SW02) 接触抵抗：200mΩ以下 クリックトルクははんだ付け後 その他、初期規格を満足すること。 (SW02) Switch contact resistance: 200mΩMAX. Must meet after soldered specification for detent torque. Must meet or exceed the initial specifications for other items.
1-7 耐落下性 Free falling	60cmの高さより製品の任意の方向からビニールタイルを張ったコンクリートの床上に自由に落下させる。 The encoder shall be fallen freely at any posture from 60cm height to the concrete floor covered with vinyl-tile, after which measurement shall be made.	著しい変形、破損等がなく クリックトルクははんだ付け後 その他、初期規格を満足すること。 (但し、端子部の変形は除く。) Get no excessive deformation or damage. Must meet after soldered specification for detent torque. Must meet or exceed the initial specifications for other items. (Except the deformation of terminals.)

					ALPS ELECTRIC CO., LTD.					
					APPD.	CHKD.	DSGD.	TITLE エンコータ・フッシュモーメンタリSW ENCODER・PUSH MOMENTARY SWITCH		
					M-DSG2	M-DSG2	M-DSG2	DOCUMENT NO.		
					S. MIZOBUCHI	A. NOMURA	H. MIURA			
SYMB	DATE	APPD	CHKD	DSGD	2011/01/12	2011/01/12	2011/01/12	S-J6 (2/2)		

CLASS No.	TITLE
-----------	-------

1. はんだ付け条件 Soldering conditions.

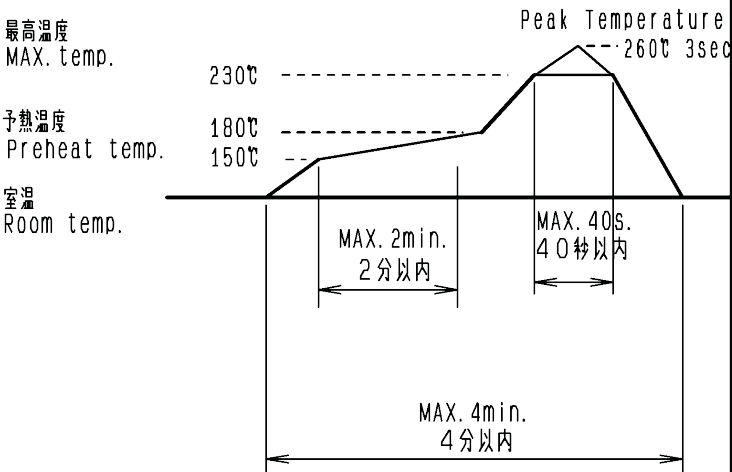
項目 Item	条件 Conditions	規格 Specifications
1-1 はんだ耐熱性 Resistance to soldering heat リフローの場合 Applied for reflow soldering	<p>下記のほかは、JIS C 0050(ただし試験方法は1Aまたは2による)に準拠する。 For procedures other than those specified below, refer to IEC Pub. 68-2-20, Test Tb Method 1A or 2.</p> <p>(下図プロファイルは、温風リフロー式を用いた場合の基板表面温度とする) (Profile shown as below is the mounting surface of PC board temperature of encoder soldered with reflow reflow soldering by hot wind blasting.</p>  <p>最高温度 MAX. temp. 230°C</p> <p>予熱温度 Preheat temp. 180°C</p> <p>室温 Room temp. 150°C</p> <p>Peak Temperature ---260°C 3sec</p> <p>MAX. 2min. 2分以内</p> <p>MAX. 40s. 40秒以内</p> <p>MAX. 4min. 4分以内</p> <p>洗 淨 : 当エンコーダは洗淨を行いません。 Washing : No washing.</p> <p>使用はんだ : 使用されるクリームはんだはフラックス含有量10~15wt%のものを 使用してください。 Solder to be used: Use creamy solder with rosin flux 10~15 wt%.</p> <p>*注記 : 当製品は、赤外線のみリフロー炉では、はんだが付かない場合がありますので、 温風リフロー炉または、赤外線+温風リフロー炉で、ご使用願います。 Comment : Soldering is no sufficient only by reflow furnance of infrated rays, so use reflow furnance by hot wind blasting or reflow furnance of infrated rays with hot wind blasting.</p>	<p>電氣的性能を満足すること。 外觀の変形および端子等の著しい ガタのないこと。 Electrical characteristics shall be satisfied. Without deformation of case or excessive looseness of terminals.</p> <p>リフロー回数: 2回 Maximum frequency of reflow soldering is 2.</p>
1-2 手はんだの場合 Applied for manual soldering	<p>温 度 : 350±10°C 但し、端子に異常加圧のないこと。 Bit temperature Extensive pressure must not be applied to the terminal.</p> <p>時 間 : 3⁺¹₀ s Application time of soldering iron</p> <p>注記: はんだ付け時のはんだホール及びフラックス等がスイッチ内に入らない様ご注意下さい。 Note: Care must be taken not allow foreign material such as solder ball or soldering flux penetrating into the encoder.</p>	<p>電氣的性能を満足すること。 外觀の変形および端子等の著しい ガタのないこと。 Electrical characteristics shall be satisfied. Without deformation of case or excessive looseness of terminals.</p> <p>手はんだ回数: 2回 Maximum frequency of manual soldering is 2.</p>

基板に挿入される金属足ははんだ付けてご使用願います。
 Solder all metal inserted fixing including terminals & metal lugs into a substrate.

					ALPS ELECTRIC CO., LTD.				
					APPD.	CHKD.	DSGD.	TITLE	
					M-DSG2	M-DSG2	M-DSG2		
					H. HAYASHI	A. NOMURA	H. MIURA	DOCUMENT NO.	
					2010/11/27	2010/11/27	2010/11/27	L-J5 (1/1)	
SYMB	DATE	APPD	CHKD	DSGD					

注記 軸受材質：亜鉛タ'イキャスト
軸材質：アルミニウム

(SW01) ENCODER
(SW02) PUSH ON SW

NOTES BUSHING MATERIAL: ZINC ALLOY DIE CASTING
SHAFT MATERIAL: ALUMINUM

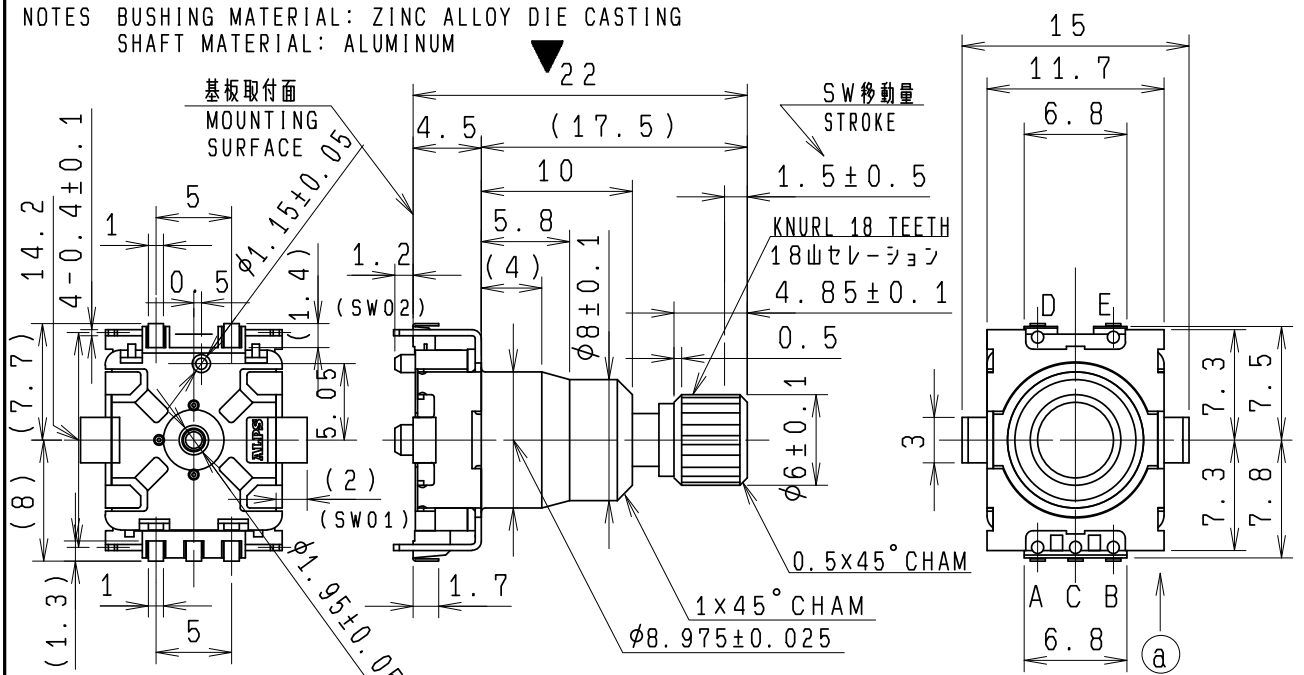

取付寸法図 許容差±0.1(参考)
斜線部ははんだラント(挿入側より)
黒塗り部は配線禁止エリア
P.W.B. MOUNTING DETAIL TOLERANCE±0.1(REFERENCE)
A SLANT LINE PART SHOWS THE SOLDER LAND
BLACK PART: DO NOT SOLDER AND NO WIRING
FOR ELECTRICAL CONTACT VIEWED FROM MOUNTING SIDE

軸角度は任意とする。
SHAFT ANGLE IS OPTIONAL.

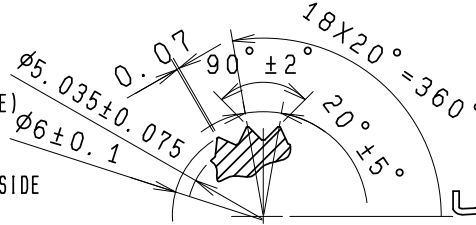

セレーション詳細図
KNURL DETAIL

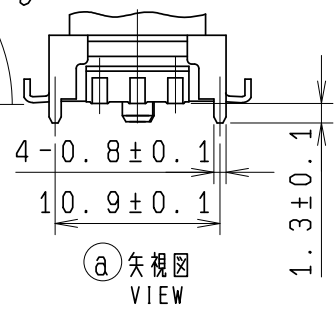

(a) 矢視図
VIEW

基板取付面の
コプラナリティは
0.1以下
COPLANARITY OF MAX
0.1mm FOR ALL
SOLDERED AREA.

(SW02)回路図
SWITCH CIRCUIT
DIAGRAM

(SW01)出力信号
ENCODER OUTPUT SIGNAL

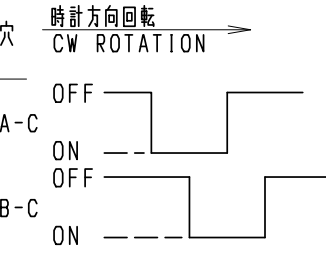
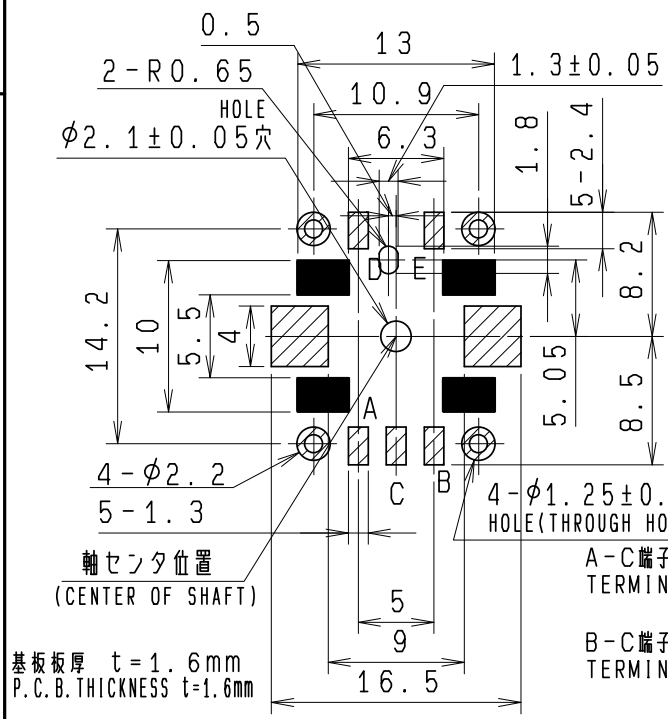
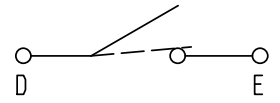

指定なき部分の許容差 TOLERANCES UNLESS OTHERWISE SPEC	
L ≤ 10	±0.3
10 < L < 100	±0.5
100 ≤ L	±0.8
角度 ANGULAR DIMENSION	±5°

基板板厚 t=1.6mm
P.C.B. THICKNESS t=1.6mm

				9P/18C	
PART NO.	MATERIAL		SPEC/NAME	FINISH	

ALPS ELECTRIC CO., LTD.

DSGD.	H. MIURA		2012-02-10	SCALE	2:1	NO.	
CHKD.	K. SASAKI		2012-02-10	TITLE	11形1軸 PUSH ON SW付エンコーダ'組立図		
初設	2011/07/22	S, M	K, S	H, M	UNIT	DOCUMENT NO.	
NO.	SYMB	DATE	APPD	CHKD	DSGD	LA2115J32	
			S. MIZOBUCHI		mm		

X-ON Electronics

Largest Supplier of Electrical and Electronic Components

Click to view similar products for [Coded Rotary Switches](#) category:

Click to view products by [ALPS](#) manufacturer:

Other Similar products are found below :

[PT65503RT](#) [Y36D02243FPLFT](#) [RTAP31S12WFLSP](#) [MADR-16H1](#) [GSER-10](#) [6KF001B-3S10R4-0](#) [EC11E153442W](#) [EC11E1534441](#) [SC-2110](#) [SD-2010TB](#) [MER-16H](#) [EDR-08](#) [USR-10](#) [FSR-08](#) [FSR-04S](#) [ESR-16](#) [HAMR-10S](#) [SDR-10H](#) [QSR-16H](#) [HAMR-16](#) [FDR-04S](#) [EDR-16S](#) [ESR-10S](#) [QDR-08H1](#) [EDR-08S](#) [ESR-16H](#) [QDR-10](#) [EDR-10S](#) [QSR-06S](#) [ESR-08S](#) [EC11E156040N](#) [EC11B15243DC](#) [EC35AH220501](#) [EC18AGB20406](#) [EC11E09244C3](#) [EC11G1534414](#) [EC11E156T402](#) [EC11E1564454](#) [EC11E15204B1](#) [EC11E1564439](#) [EC50A0920403](#) [ED103180-FE14.5S7.5-A16-1010](#) [ED08E42S-FE15C7.0-A16-1020](#) [ED08C030-FE18C9.0-A16-1002X](#) [ED08C210-FE18A6.0-A16-1002](#) [ED08C150-BM20S6.0-A16-1026](#) [ED103010-SP17S8.0-A16-1012](#) [ED113020-FB15S7.0-C12-0005](#) [ED121220-FB20B7.0-C24-0001-G219](#) [ED231010-FB35A10-A40-1001](#)