

CLASS No.	TITLE 回転形コードスイッチ規格書 ROTATIONAL CORD SWITCH SPECIFICATION	EC35AH220501
-----------	--	--------------

1. 一般事項 General

1-1 適用範囲 Scope

この仕様書は主として電子機器に用いる微小電流回路用35形コードスイッチに適用する。
This specification applies to 35mm size rotary cord switch for microscopic current circuits, used in electronic equipment.

1-2 標準状態 Standard atmospheric conditions

測定は特に指定のない限り、次の状態で行なう。
Unless otherwise specified, the standard range of atmospheric conditions for making measurements and tests is as follows:

温度 Ambient temperature : 15°C to 35°C
 相対湿度 Relative humidity : 25% to 85%
 気圧 Air pressure : 86kPa to 106kPa

但し、疑義を生じた場合は、次の基準状態で行なう。

If there is any doubt about the results, measurements shall be made within the following limits:

温度 Ambient temperature : 20 ± 1°C
 相対湿度 Relative humidity : 63% to 67%
 気圧 Air pressure : 86kPa to 106kPa

1-3 使用温度範囲

Operating temperature range : -40°C to +85°C

1-4 保存温度範囲

Storage temperature range : -40°C to +85°C

2. 構造 Construction

2-1 寸法 Dimensions

添付組立図による。
Refer to attached drawing.

3. 定格 Rating

3-1 定格容量 Rating : D.C. 5V 10mA (1mA MIN)

4. 電気的性能 Electrical characteristics

項目 Item	条件 Conditions	規格 Specifications																	
4-1 出力信号 Output signal format		破線はクリックの位置を示す。 The broken line shows detent position.																	
	<Fig 1>																		
	<table border="1"> <thead> <tr> <th>軸回転方向 Shaft rotational direction</th> <th>信号 Signal</th> <th>出力波形 Output</th> </tr> </thead> <tbody> <tr> <td rowspan="3">時計方向 C. W.</td> <td>A(A-D端子間) A(Terminal A-D)</td> <td>OFF ———— ON </td> </tr> <tr> <td>B(B-D端子間) B(Terminal B-D)</td> <td>OFF ———— ON </td> </tr> <tr> <td>C(C-D端子間) C(Terminal C-D)</td> <td>OFF ———— ON </td> </tr> <tr> <td rowspan="3">反時計方向 C. C. W.</td> <td>A(A-D端子間) A(Terminal A-D)</td> <td>OFF ———— ON </td> </tr> <tr> <td>B(B-D端子間) B(Terminal B-D)</td> <td>OFF ———— ON </td> </tr> <tr> <td>C(C-D端子間) C(Terminal C-D)</td> <td>OFF ———— ON </td> </tr> </tbody> </table>	軸回転方向 Shaft rotational direction	信号 Signal	出力波形 Output	時計方向 C. W.	A(A-D端子間) A(Terminal A-D)	OFF ———— ON	B(B-D端子間) B(Terminal B-D)	OFF ———— ON	C(C-D端子間) C(Terminal C-D)	OFF ———— ON	反時計方向 C. C. W.	A(A-D端子間) A(Terminal A-D)	OFF ———— ON	B(B-D端子間) B(Terminal B-D)	OFF ———— ON	C(C-D端子間) C(Terminal C-D)	OFF ———— ON	
軸回転方向 Shaft rotational direction	信号 Signal	出力波形 Output																	
時計方向 C. W.	A(A-D端子間) A(Terminal A-D)	OFF ———— ON																	
	B(B-D端子間) B(Terminal B-D)	OFF ———— ON																	
	C(C-D端子間) C(Terminal C-D)	OFF ———— ON																	
反時計方向 C. C. W.	A(A-D端子間) A(Terminal A-D)	OFF ———— ON																	
	B(B-D端子間) B(Terminal B-D)	OFF ———— ON																	
	C(C-D端子間) C(Terminal C-D)	OFF ———— ON																	

ALPS ELECTRIC CO., LTD.

SYMB	DATE	APPD	CHKD	DSGD	APPD.	CHKD.	DSGD.	TITLE
					2009-05-25	2009-05-25	2009-05-25	回転形コードスイッチ ROTATIONAL CORD SWITCH
					Y. KATO	S. HAYASHIDA	H. KIMURA	DOCUMENT NO.
								5P35H-14(1/4)

CLASS NO.	TITLE 回転形コードスイッチ規格書 ROTATIONAL CORD SWITCH SPECIFICATION	
-----------	--	--

項目 Item	条件 Conditions	規格 Specifications
4-2 分解能 Resolution	1回転にて出力されるパルス数 Number of pulses in 360° rotation.	各相10パルス/360° 10 pulses/360° for each phase
4-3 スイッチング特性 Switching characteristics	<p>下記測定回路<fig. 2>を用い、回転軸を$360^\circ \cdot s^{-1}$の速さで回転し測定する。 Measurement shall be made under the condition as follows. 1) Shaft rotational speed : $360^\circ \cdot s^{-1}$ 2) Test circuit : <fig. 2></p> <div style="text-align: center;"> <p><fig. 2></p> </div> <div style="text-align: right; margin-top: 10px;"> <p><fig. 3></p> </div> <p>(注記) コードOFF状態 : 出力電圧が2.5V以上の状態を言う。 コードON状態 : 出力電圧が2.5V以下の状態を言う。 (note) Code-OFF area : The area which the voltage is 2.5V or more. code-ON area : The area which the voltage is 2.5V or less.</p>	
1) チャタリング Chattering	コードのOFF→ON及びON→OFFの際の、出力2.5Vの通過時間にて規定する。 Specified by the signal's passage time to 2.5V of each switching position (code OFF→ON or ON→OFF).	$t_1, t_3 \leq 5ms$
2) 摺動ノイズ (バウンス) Sliding noise (Bounce)	コードONの部分の2.5V以上の電圧変動時間とし、チャタリング t_1, t_3 両者との間に1ms以上の2.5V以下のON部分を有するものとする。また、摺動ノイズ間に2.5V以下の範囲が1ms以上ある場合は、別の摺動ノイズと判断する。 Specified by the time of voltage change exceed 2.5V in code-ON area. When the bounce has code-ON time less than 1ms between chattering (t_1 or t_3), the voltage change shall be regarded as a part of chattering. When the code-ON time between 2 bounces is less than 1ms, they are regarded as 1 linked bounce.	$t_2 \leq 5ms$
4-4 絶縁抵抗 Insulation resistance	端子-取付板間にD. C. 250V印加する。 Measurement shall be made under the condition which a voltage of 250V D.C. is applied between individual terminals and bracket.	端子-取付板にて100MΩ以上 Between individual terminals and bracket. 100MΩ MIN.
4-5 耐電圧 Dielectric strength	端子-取付板間A. C. 300V1分間又は、A. C. 360V2秒間印加する。 (リーク電流1mA) A voltage of 300V A.C. shall be applied for 1min or a voltage of 360V A.C. shall be applied for 2s between individual terminals and bracket. (Leak current:1mA)	損傷・アーク・絶縁破壊がないこと。 Without damage to parts, arcing or breakdown.

ALPS ELECTRIC CO., LTD.				
APPD.	CHKD.	DSGD.	TITLE 回転形コードスイッチ ROTATIONAL CORD SWITCH	
2009-05-25	2009-05-25	2009-05-25	DOCUMENT NO.	
SYMB	DATE	APPD	CHKD	DSGD
		Y. KATO	S. HAYASHIDA	H. KIMURA
			5P35H-14(2/4)	

CLASS No.	TITLE 回転形コードスイッチ規格書 ROTATIONAL CORD SWITCH SPECIFICATION
-----------	--

5. 機械的性能 Mechanical characteristics

項目 Item	条件 Conditions	規格 Specifications
5-1 全回転角度 Total rotational angle		360° (エンドレス) 360° (Endless)
5-2 クリックトルク Detent torque	5rpmの速度で軸を回転させて測定する。 When shaft is rotated by speed of 5rpm.	18 ⁺⁶ / ₅ mN・m
5-3 クリック点数及び位置 Number and position of detents.		30点クリック 30 detents (ステップ角度 12°±3°) (Step angle:12°±3°)
5-4 端子強度 Terminal strength	端子先端の任意の方向に5Nの力を1分間加える。 A static load of 5N be applied to the tip of terminals for 1min in any direction.	端子の破損、著しいカクタがないこと。 但し、端子の曲がりは可とする。 Without damage or excessive looseness of terminals. Terminal bend is permitted.
5-5 軸の押し引き強度 Push-pull strength of shaft	軸の押し及び引張り方向に100Nの力を10秒間加える。 (セット実装状態) Push and pull static load of 100N shall be applied to the shaft in the axial direction for 10s. (After installing)	軸の破損、著しいガタのないこと。 感触に異常がないこと。 Without damage or excessive play in shaft. No excessive abnormality in rotational feeling.
5-6 軸ガタ Shaft wobble	軸先端より2mmの位置に20mN・mの曲げモーメントを加える。 Bending moment of 20mN・m to be applied to the shaft at 2mm from the top of shaft.	0.2mmp以下 less

ALPS ELECTRIC CO., LTD.

SYMB	DATE	APPD	CHKD	DSGD	APPD.	CHKD.	DSGD.	TITLE
					2009-05-25	2009-05-25	2009-05-25	回転形コードスイッチ ROTATIONAL CORD SWITCH
					Y. KATO	S. HAYASHIDA	H. KIMURA	DOCUMENT NO.
								5P35H-14(3/4)

CLASS No. _____	TITLE 回転形コードスイッチ規格書 ROTATIONAL CORD SWITCH SPECIFICATION
--------------------	--

6. 耐久性能 Endurance characteristics.

項目 Item	条件 Conditions	規格 Specifications
6-1 しゅう動寿命性能 Rotational life	無負荷で軸を毎時1000サイクルの速さで、50,000サイクル断続動作を行う。 (1サイクルは、360°1往復) The shaft of encoder shall be rotated to 50,000 cycles at a speed of 1000cycles per hour without electrical load, after which measurements shall be made. (1 cycle: rotate 360° CCW rotate 360° CW)	クリックトルク: 18±9mN・m Detent torque その他初期規格を満足すること。 Except above items, shall be meet initial specification.
6-2 耐湿性 Damp heat	温度60±2°C、湿度90~95%の恒温湿槽中に240±10時間放置後取り出し、表面の水分をふき取り常温常湿中に1.5時間放置後測定する。 The encoder shall be stored at a temperature of 60±2°C with relative humidity of 90% to 95% for 240±10 hours in a thermostatic chamber. Then the encoder shall be taken out of the chamber and its surface moisture shall be removed. And then the encoder shall be subjected to standard atmospheric conditions for 1.5 hour, after which measurement shall be made.	初期規格を満足すること。 Shall be meet initial specifications.
6-3 耐熱性 Dry heat	温度85±3°Cの恒温槽中に240±10時間放置し、常温常湿中に1.5時間放置後測定する。 The encoder shall be stored at a temperature of 85±3°C for 240±10 hours in a thermostatic chamber. Then the encoder shall be maintained at standard atmospheric conditions for 1.5 hour, after which measurements shall be made.	
6-4 耐寒性 Cold	温度-40±3°Cの恒温槽中に240±10時間放置後取り出し、表面の水分をふき取り常温常湿中に1.5時間放置後測定する。 The encoder shall be stored at a temperature of -40±3°C for 240±10 hours in a thermostatic chamber. Then the encoder shall be taken out of the chamber and its surface moisture shall be removed. And then the encoder shall be subjected to standard atmospheric conditions for 1.5 hour, after which measurement shall be made.	
6-5 温度サイクル Change of temperature	下表に示した温度サイクルを連続240回行う。表面の水分をふき取り常温常湿中に1.5時間放置後測定する。 The encoder shall be subjected to 240 successive change of temperature cycls, each as shown in table below. Then its surface moisture shall be removed. And then the encoder shall be subjected to standard atmospheric conditions for 1.5 hour, after which measurements shall be made.	

段階 Step	温度 Temperature	放置時間 Durationure
1	-40 ₋₃ ⁰ °C	30分 min
2	常温 Standard atmospheric conditions	30分 min
3	+85 ₀ ⁺³ °C	30分 min
4	常温 Standard atmospheric conditions	30分 min

					ALPS ELECTRIC CO., LTD.					
					APPD.	CHKD.	DSGD.	TITLE 回転形コードスイッチ ROTATIONAL CORD SWITCH		
					2009-05-25	2009-05-25	2009-05-25			
					Y. KATO	S. HAYASHIDA	H. KIMURA	DOCUMENT NO. 5P35H-14(4/4)		
SYMB	DATE	APPD	CHKD	DSGD						

CLASS No.	TITLE
-----------	-------

1. はんだ耐熱 Resistance to soldering heat

下記の「はんだ付け条件」にて絶縁体の変形、破損のないこと、感触に異常のないこと。
 At the specified by the soldering conditions below.
 There shall be no deformation or cracks, in molded part.
 No excessive abnormality in rotational feeling.

はんだ付け条件 Soldering conditions

手はんだの場合 Manual soldering

△ 温度350°C以下、時間3秒以内 △
 Bit temperature of soldering iron : 350°C or less.
 Application time of soldering iron : within 3s.

ディップはんだの場合 Dip soldering

使用基板 : t1.6両面銅張積層板
 Printed wiring board: Both-sided copper clad laminate board with thickness of 1.6mm.

フラックス : 比重0.82以上のフラックスを用い発泡式フラクサーにて発泡面高さは、基板板厚の3分の2。
 Flux:
 ・Specific gravity: 0.82 or more.
 ・Flux shall be applied to the board using a bubble foaming type fluxer.
 ・The board shall be soaked in the flux bubble only to the 2/3 of its thickness.

プリヒート : 基板表面温度100°C以下、時間2分以内
 Preheating:
 ・Surface temperature of board: 100°C or less.
 ・Preheating time: within 2 min.

はんだ : 温度260±5°C、時間5±1秒
 Soldering:
 ・Solder temperature: 260±5°C.
 ・Immersion time: Within 5±1s.

以上の工程を1回または2回通過する。
 Apply the above soldering process for 1 or 2 times.

					 ALPS ELECTRIC CO., LTD.			
		APPD.	CHKD.	DSGD.	TITLE			
		1-設2	1-設2	1-設2				
		K. KAWASAKI	S. MIZOBUCHI	H. MIURA	DOCUMENT NO.			
		1997/06/12	1997/06/12	1997/06/11	L-E1 (1/1)			
△ 2	2004-02-23	S. M	H. H	H. I				
SYMB	DATE	APPD	CHKD	DSGD				

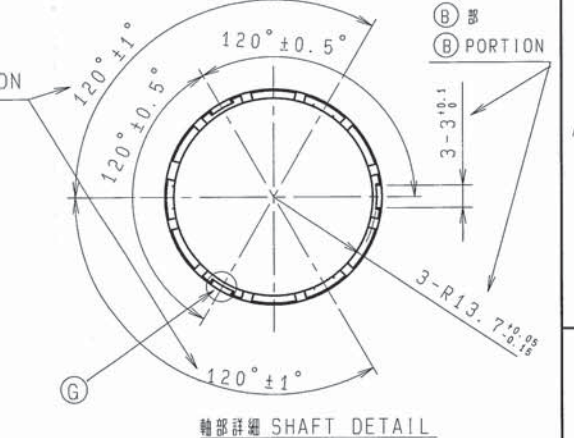
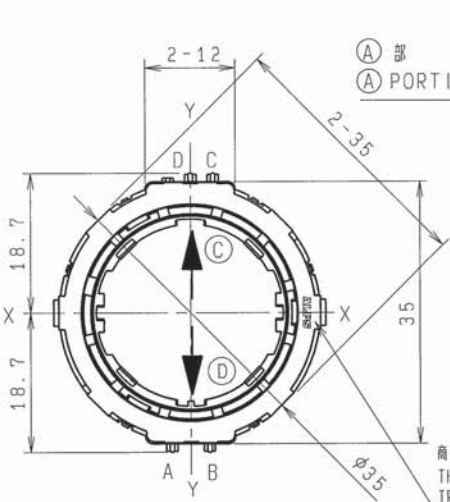
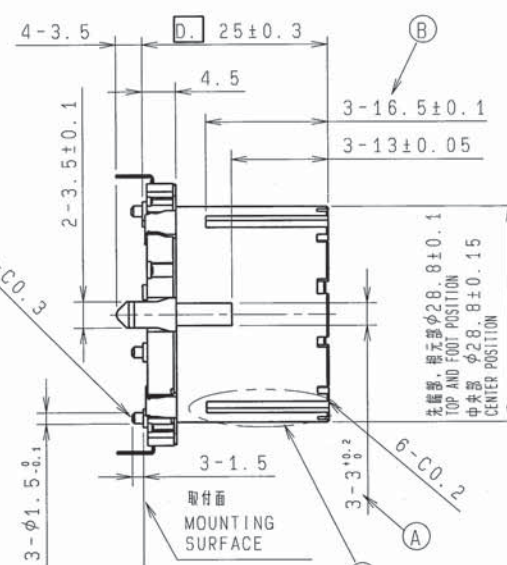
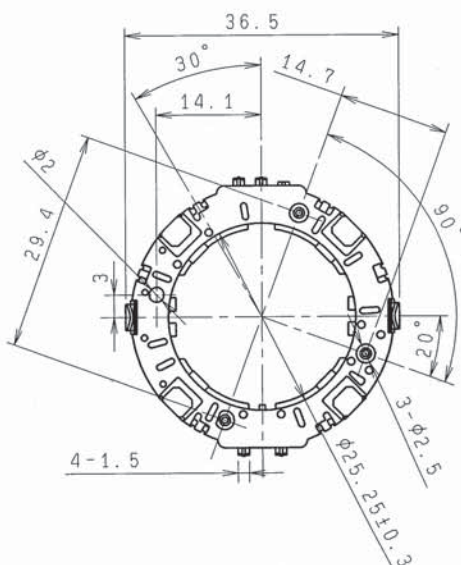

商標の位置は任意とする。
THE POSITION OF TRADE MARK IS OPTIONAL.

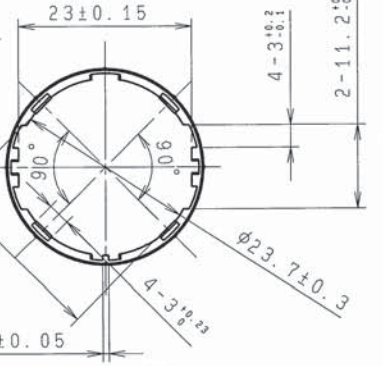

取付寸法図 部品挿入側
許容差 ±0.1 あるいは ±1°
斜線部は配線禁止部を示すが参考であり、
このエリアへの配線を絶対に禁止するものではない。
P. W. B. MOUNTING DETAIL
TOLERANCE ±0.1 OR ±1
VIEWED FROM MOUNTING SIDE.
KEEP OUT AREA SHOWN IN SHADE PORTION
FOR REFERENCE, AND DOES NOT MEAN ABSOLUTE
PROHIBITION OF WIRING THERE.

#4の範囲
SPECIFIED AREA
OF #4

先端部、根元部 2-1.54^{±0.12}
TOP AND FOOT POSITION
中央部 2-1.54^{±0.15}
CENTER POSITION

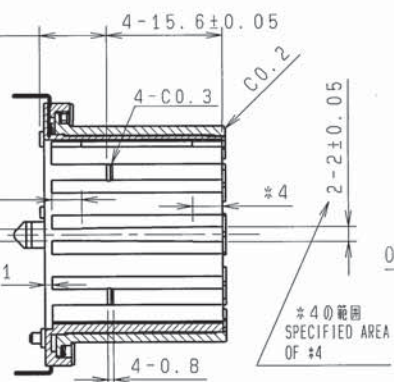

断面YY
SECTION YY

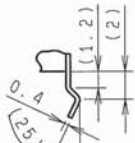

取付板のスナップ部詳細
RETENTION
FEATURE DETAIL

指定なき部分の許容差 TOLERANCES UNLESS OTHERWISE SPEC	
L ≤ 10	±0.3
10 < L ≤ 100	±0.5
100 ≤ L	±0.8
角度 ANGULAR DIMENSION	±5°

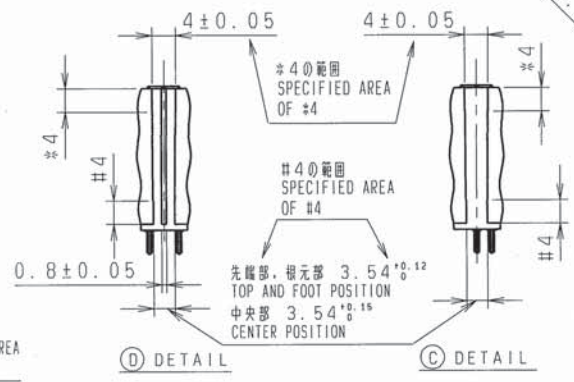

D DETAIL

C DETAIL

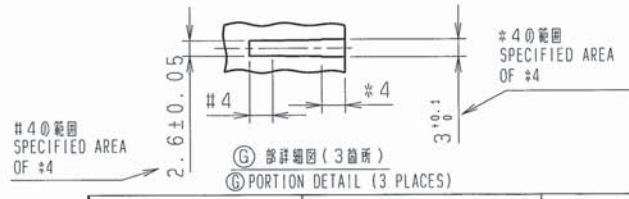

G部詳細図 (3箇所)
G PORTION DETAIL (3 PLACES)

出力信号 OUTPUT SIGNAL	時計方向回転 CW ROTATION	クリック機構 DETENT
A-D端子間 TERMINAL A-D	ON	OFF
B-D端子間 TERMINAL B-D	ON	OFF
C-D端子間 TERMINAL C-D	ON	OFF

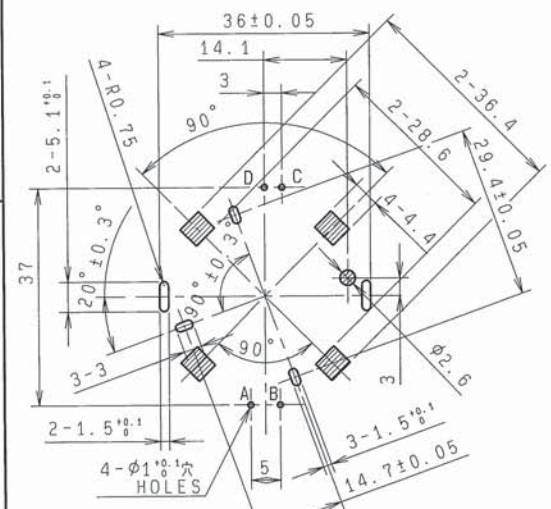

端子先端形状
TERMINAL DETAIL

PART NO.	MATERIAL	SPEC/NAME	FINISH
ALPS ELECTRIC CO., LTD.			
DSGD.	H. KIMURA	2009-05-15	SCALE NO.
CHKD.	A. NOMURA	2009-05-15	TITLE
APPD.	Y. KATO	2009-05-15	DOCUMENT NO.

30C
35形ABC SW
P35H03012

CLASS NO. _____

TITLE _____

<はんだ付け時の注意事項>

Caution for soldering

図のようにP. W. Bの上面にはんだ付けをする配線は避け下さい。

Please avoid soldering on upper surface of P. W. B. as shown

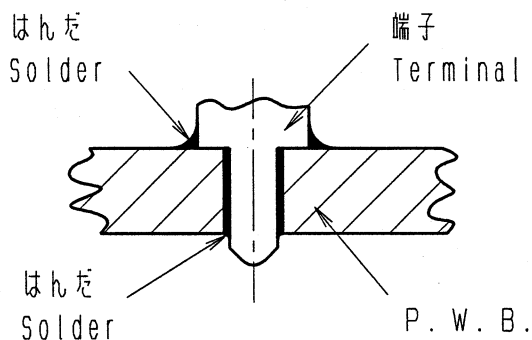

基板に挿入される金属足はんだ付けしてご使用願います。

Solder all metal inserted fixing including terminals & metal lugs into a substrate.

					ALPS ALPS ELECTRIC CO., LTD.			
					APPD. DSG1	CHKD. DSG1	DSGD. DSG1	TITLE _____
					Y. YOSHIOKA	Y. SATO	Y. OYA	DOCUMENT NO.
△1	09-01-27	Y, K	Y, K	H, M	1996/01/11	1996/01/11	1996/01/11	4K-1 (1/1)
SYMB	DATE	APPD	CHKD	DSGD				

X-ON Electronics

Largest Supplier of Electrical and Electronic Components

Click to view similar products for [Coded Rotary Switches](#) category:

Click to view products by [ALPS](#) manufacturer:

Other Similar products are found below :

[PT65503RT](#) [Y36D02243FPLFT](#) [RTAP31S12WFLSP](#) [MADR-16H1](#) [GSER-10](#) [6KF001B-3S10R4-0](#) [EC11E153442W](#) [EC11E1534441](#) [SC-2110](#) [SD-2010TB](#) [MER-16H](#) [EDR-08](#) [USR-10](#) [FSR-08](#) [FSR-04S](#) [ESR-16](#) [HAMR-10S](#) [SDR-10H](#) [QSR-16H](#) [HAMR-16](#) [FDR-04S](#) [EDR-16S](#) [ESR-10S](#) [QDR-08H1](#) [EDR-08S](#) [ESR-16H](#) [QDR-10](#) [EDR-10S](#) [QSR-06S](#) [ESR-08S](#) [EC11E156040N](#) [EC11B15243DC](#) [EC35AH220501](#) [EC18AGB20406](#) [EC11E09244C3](#) [EC11G1534414](#) [EC11E156T402](#) [EC11E1564454](#) [EC11E15204B1](#) [EC11E1564439](#) [EC50A0920403](#) [ED103180-FE14.5S7.5-A16-1010](#) [ED08E42S-FE15C7.0-A16-1020](#) [ED08C030-FE18C9.0-A16-1002X](#) [ED08C210-FE18A6.0-A16-1002](#) [ED08C150-BM20S6.0-A16-1026](#) [ED103010-SP17S8.0-A16-1012](#) [ED113020-FB15S7.0-C12-0005](#) [ED121220-FB20B7.0-C24-0001-G219](#) [ED231010-FB35A10-A40-1001](#)