

CLASS NO.	TITLE ROTARY SENSOR	RD6R1A0019
-----------	------------------------	------------

1.一般事項 General requirements

- 1.1 使用温度範囲 Usable temperature : -40°C to +85°C
 1.2 保存温度範囲 Storage temperature : -40°C to +95°C
 1.3 試験条件 Test conditions

特に指定のない限り、試験及び測定は常温、常湿、常気圧の標準状態で行う。

Unless otherwise specified, the standard range of atmospheric conditions for making measurements and test is as follows:

温度 Ambient temperature : 5°C to 35°C
 湿度 Relative humidity : 45% to 85% RH
 気圧 Air pressure : 86kpa to 106kpa

但し、判定に疑義を生じた場合は、次の条件にて行うこと。

If there is any doubt about the results, measurement shall be made within the following limits:

温度 Ambient temperature : 20 ± 2°C
 湿度 Relative humidity : 60% to 70%
 気圧 Air pressure : 86kpa to 106kpa

2.外観、寸法 Apperance/Dimension

- 2.1 外観 破損・変形等の機械的損傷がないこと。
 Appearance No mechanical damages such as breaks and deformation.
 2.2 寸法 組立図による。
 Dimension Specified in the product drawing.

3.電気的特性 Electrical characteristics

No.	項目 Item	条件 Conditions	規格 Specifications
3.1	定格電圧 Rated voltage	—	D.C. 5V±0.5V
3.2	定格電力 Rated power	—	0.1W
3.3	電気的有効可変角度 Effective electrical angle	—	±75° (150°)
3.4	リニアリティ保証範囲 Guarantee limit for linearity	—	±70° (140°)
3.5	全抵抗値 Total resistance	端子 1-3 間を規定。 Between terminal 1 and terminal 3.	6kΩ ±20%

ALPS ELECTRIC CO., LTD.

SYMB	DATE	APPD	CHKD	DSGD	APPD. CENG2(G) Apr. 12' 16 S.Urushihara	CHKD. CENG2 Apr. 12' 16 T.Ohara	DSGD. CENG2 Apr. 12' 16 Y.Shimizu	TITLE 規格書 SPECIFICATIONS	DOCUMENT NO. 5RD6R1-A19	(1/9)
------	------	------	------	------	--	--	--	-----------------------------	----------------------------	-------

Confidential

CLASS NO.	TITLE	ROTARY SENSOR
-----------	-------	---------------

3.電気的特性 Electrical characteristics

No.	項目 Item	条件 Conditions	規格 Specifications
3.6	出力電圧直線性 Linearity	測定回路<図 2>を用い、回転軸を 6rpm の速さで回転し測定する。 Measurement shall be made under the condition as follows. 1) rotation speed : 6rpm 2) measurement circuit : fig.2 基準勾配 : Reference taper(ideal line) 出力電圧比 50%の位置を通る傾き 100%/150°。 The line shall be drawn at the 50% output point with the slope of 100%/150° .	基準勾配に対する偏差: Allowable deviation: 範囲 Area ±70° (140°) 直線性 Linearity ±2% 出力電圧比 : <図 1>参照 (Output voltage ratio : fig.1)

<図 1>
< Fig.1>

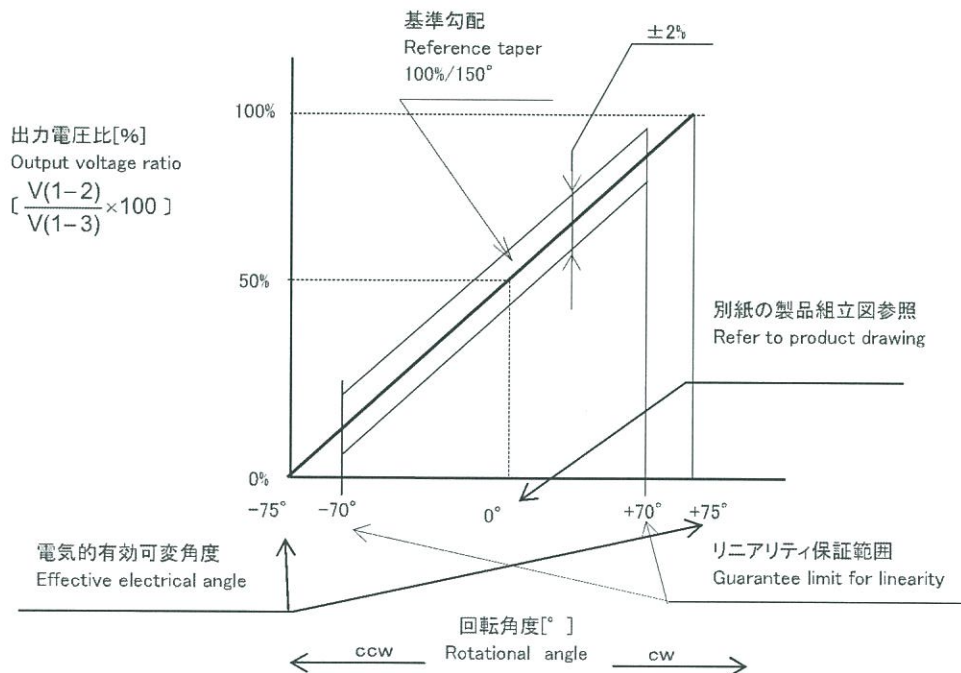

<図 2>
<Fig.2> [測定回路図]
[Linearity measuring circuit]

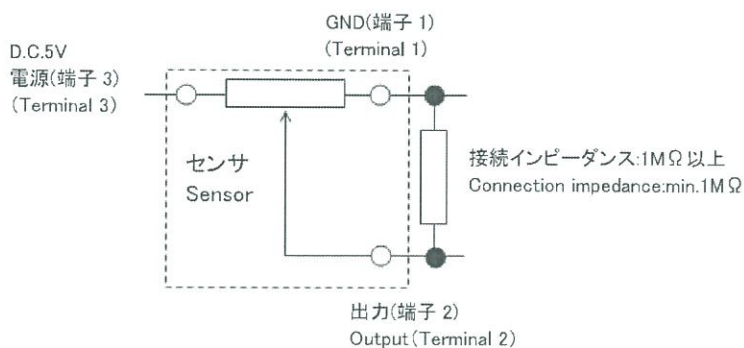

					ALPS ELECTRIC CO., LTD.					
					APPD.	CHKD.	DSGD.	TITLE	規格書 SPECIFICATIONS	
					CENG2(G)	CENG2	CENG2	DOCUMENT NO.		
					Apr. 12' 16	Apr. 12' 16	Apr. 12' 16	5RD6R1-A19		
SYMB	DATE	APPD	CHKD	DSGD	S.Urushihara	T.Ohara	Y.Shimizu		5RD6R1-A19	(2/9)

CLASS NO.	TITLE	
	ROTARY SENSOR	

4.機械的性能 Mechanical characteristics

No.	項目 Item	条件 Conditions	規格 Specifications
4.1	回転トルク Rotational torque	回転軸を貫通軸に対して直角にし、回転トルク計を用いて 10rpm の速度で測定する。 The rotational shaft must be right-angled toward the hollow shaft. Measuring instrument is torque meter and rotational speed at 10rpm.	0.1N・m 以下 0.1N・m Max.
4.2	貫通軸の押し強度 Pushing strength of the hollow shaft	貫通軸の回転方向に対して直角方向に、10N の負荷を 10 秒間加える。 The static load of 10N shall be applied in the axial direction of the hollow shaft for 10 seconds, with the sensor mounted in assembly condition.	電気的特性に異常がないこと。 Electrical characteristics shall be satisfied.
4.3	貫通軸の側圧強度 Lateral strength of the hollow shaft	軸を挿入しケース上面より 10mm の位置に 1.2N の負荷を 10 秒間加える。 Insert the shaft and the static load of 1.2N shall be applied in the set point and direction of the shaft for 10 seconds, with the sensor mounted in assembly condition.	電気的特性に異常がないこと。 Electrical characteristics shall be satisfied.
4.4	端子の押し引き強度 Push-pull strength of the terminal	端子先端に押し又は引き方向へ 10N の力を 1 分間加える。 The static pull or push load of 10N shall be applied to the end of terminals for 1min.	端子の破損、著しいガタがないこと。 端子の曲がりは可とする。 Without a damage or excessive looseness of terminals. Terminal bend is permitted.

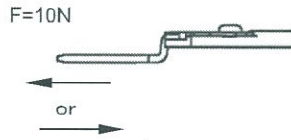
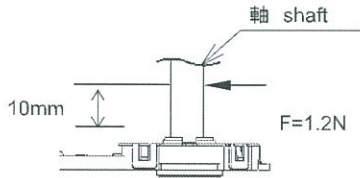
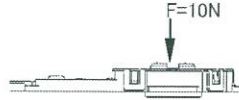

ALPS ELECTRIC CO., LTD.

APPD. CENG2(G) Apr. 12' 16	CHKD. CENG2 Apr. 12' 16	DSGD. CENG2 Apr. 12' 16
S.Urushihara	T.Ohara	Y.Shimizu

TITLE 規格書 SPECIFICATIONS
DOCUMENT NO. 5RD6R1-A19

SYMB	DATE	APPD	CHKD	DSGD
------	------	------	------	------

(3/9)

CLASS NO.	TITLE
	ROTARY SENSOR

5.耐久性能 Durability

5.1 測定条件 Measurement conditions

耐久試験後、標準状態に1時間以上放置後、各特性を測定すること。
破損、変形等の機械的損傷がないこと。

The sensor shall be maintained at standard atmospheric conditions for minimum 1H, after which measurements shall be made.
Without mechanical damage such as breaks and deformation.

5.2 耐久試験条件 Durability test conditions

No.	項目 Item	条件 Conditions	規格 Specifications
5.2.1	作動耐久試験 Rotational life	1)周囲温度 Expose temperature 標準状態 Standard range of atmospheric condition 2)作動範囲 Operating angle ±70° (140°) 3)作動速度 Rotational speed 6 rpm 4)作動回数 Operating cycles 500,000 cycles 5)電氣的負荷 Power supply D.C. 5V 印加 D.C 5V power supplied 7)貫通軸の傾き Incline of the hollow shaft 1° max. 8)貫通軸への側圧 Side load of the hollow shaft 加えないこと。 Do not add.	3.5 :初期値±20% initial total resistance±20% 3.6 :±3 % 4.1 :初期規格を満足すること The same as the initial specifications.
5.2.2	高温放置試験 High temperature soak	1)槽内温度 Storage temperature +95±3°C 2)放置時間 Storage time 168 Hour 3)電氣的負荷 Power supply D.C. 5V 印加 D.C 5V power supplied	3.5 :初期値±20% :initial total resistance±20% 3.6, 4.1 :初期規格を満足すること : The same as the initial specifications.
5.2.3	低温放置試験 Low temperature soak	1)槽内温度 Storage temperature -40±3°C 2)放置時間 Storage time 168 Hour 3)電氣的負荷 Power supply D.C. 5V 印加 D.C. 5V power supplied	3.5 :初期値±20% :initial total resistance±20% 3.6, 4.1 :初期規格を満足すること : The same as the initial specifications.

ALPS ELECTRIC CO., LTD.

SYMB	DATE	APPD	CHKD	DSGD	APPD. CENG2(G) Apr. 12' 16 S.Urushihara	CHKD. CENG2 Apr. 12' 16 T.Ohara	DSGD. CENG2 Apr. 12' 16 Y.Shimizu	TITLE 規格書 SPECIFICATIONS DOCUMENT NO. 5RD6R1-A19
------	------	------	------	------	--	--	--	---

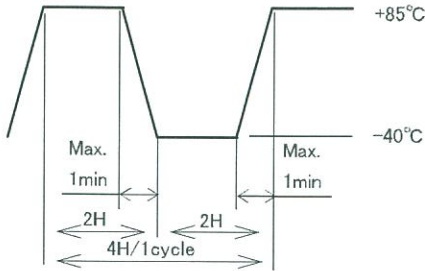
CLASS NO.	TITLE		
	ROTARY SENSOR		
No.	項目 Item	条件 Conditions	規格 Specifications
5.2.4	熱衝撃試験 Heat shock	<p>1)温度/時間サイクル Temperature/Cycle time 以下の温度/時間プロファイルにて実施する。 Shown in below temperature/cycle time profile.</p>  <p>2)サイクル数 Operating cycle 100 cycles 3)電氣的負荷 Power supply D.C. 5V 印加 D.C. 5V power supplied</p>	<p>3.5 :初期値±20% :initial total resistance±20%</p> <p>3.6, 4.1 :初期規格を満足すること :The same as the initial specifications.</p>
5.2.5	耐湿試験 Humidity	<p>1)槽内温度 Storage temperature +80°C 2)槽内湿度 Storage Humidity +90 to 95%R.H. 3)放置時間 Storage time 96 Hour 4)電氣的負荷 Power supply D.C.5V 印加 D.C.5V. power supplied.</p>	<p>3.5 :初期値±20% :initial total resistance±20%</p> <p>3.6, 4.1 :初期規格を満足すること :The same as the initial specifications.</p>
5.2.6	振動試験 Vibration	<p>1)重力加速度 Gravity 21.5m/s² 2)振動周波数 Frequency range 4000cpm 3)加振時間 Period X,Y,Z 各方向に各 4 時間 4 hours in each of 3 mutually perpendicular planes. 4)電氣的負荷 Power supply D.C.5V 印加 D.C.5V. power supplied.</p>	<p>3.5 :初期値±20% :initial total resistance±20%</p> <p>3.6, 4.1 :初期規格を満足すること :The same as the initial specifications.</p>

ALPS ELECTRIC CO., LTD.

SYMB	DATE	APPD	CHKD	DSGD	APPD. CENG2(G) Apr. 12' 16 S.Urushihara	CHKD. CENG2 Apr. 12' 16 T.Ohara	DSGD. CENG2 Apr. 12' 16 Y.Shimizu	TITLE 規格書 SPECIFICATIONS	DOCUMENT NO. 5RD6R1-A19	(5/9)
------	------	------	------	------	--	--	--	-----------------------------	----------------------------	-------

Confidential

CLASS NO.	TITLE	
	ROTARY SENSOR	

[参考]耐久試験条件[Reference]Durability test conditions

項目 Item	条件 Conditions	規格 Specifications
グリス付着作動耐久試験 Rotational life with grease	1)周囲温度 Expose temperature	標準状態 Standard range of atmospheric condition
	2)作動範囲 Operating angle	±70° (140°)
	3)作動速度 Rotational speed	6rpm
	4)作動回数 Operating	150,000cycles
	5)電氣的負荷 Power supply	D.C. 5V 印加 D.C. 5V power supplied.
	6)付着グリス Adhesion grease	KLUEBERSYNTH GL 44-32 KR 抵抗体面に塗布、3mg 以下 Grease was spread on the resistive element surface. Adhesion weight is 3mg max.
	7)貫通軸の傾き Incline of the hollow shaft	1° max.
	8)貫通軸への側圧 Side load of the hollow shaft	加えないこと。 Do not add.
※ 疑義が生じた場合は弊社試験機及び上記条件にて判定を行うこととする。 ※ When the doubt is caused in the judgment, it evaluates it according to our testing machine and condition.		
3.5		: 初期値±20%
3.6		: initial total resistance±20% : ±3%
4.1		: 初期規格を満足すること : The same as the initial specifications.

					ALPS ELECTRIC CO., LTD.			
					APPD. CENG2(G) Apr. 12' 16	CHKD. CENG2 Apr. 12' 16	DSGD. CENG2 Apr. 12' 16	TITLE 規格書 SPECIFICATIONS
SYMB	DATE	APPD	CHKD	DSGD	S.Urushihara	T.Ohara	Y.Shimizu	DOCUMENT NO.
								5RD6R1-A19
								(6/9)

Confidential

CLASS NO.	TITLE
	ROTARY SENSOR

6. 注記(使用上の注意事項) Attention about use

6.1 グリス浸入について About infiltration of grease

本製品は密閉構造ではありません。そのため、連結する軸にグリスがついている場合、グリスが製品に入るのを防いでください。グリスが製品の中に入った場合、製品特性が劣化する可能性があります。

The sensor is not close up to tight. Therefore, in case of using grease on connecting shaft, please prevent grease coming into the product. If grease gets inside the product, the product may deviate from the specified characteristics.

6.2 接続インピーダンスについて About impedance

本製品は<図 3>のように、その出力をマイコンの A/D ポートに直接接続して使うことを前提に製作されています。

つまり、接続インピーダンスの値はメガオームオーダーを前提とし、センサ内部の接触抵抗をかなり高めに設定しております。

よって、<図 4>のような回路でご使用になる場合は、接続インピーダンスが 1MΩ 以下にならないようにご配慮願います。

Since this sensor is designed to use with output is connected directly to the A/D port, impedance is considered to mega ohm level, and then contact resistance in the sensor is higher. Please refer to Fig.3.

So when you use it in the circuit like Fig.4, please make sure that impedance should be over than 1M ohm.

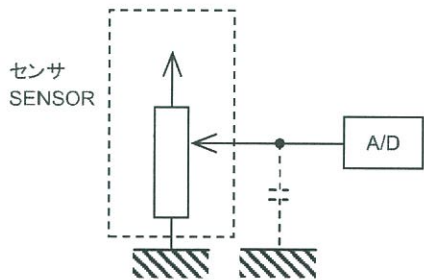

<図 3> Fig.3

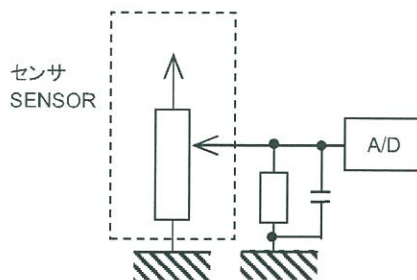

<図 4> Fig.4

6.3 ノイズ対策について about countermeasure for noise

本製品からのデータ取り込みの際、稀に発生する取り込みミスや、外部ノイズの飛び込みと思われる、再現性のないノイズの影響を最小限に抑えるため、ソフト上で以下のようなご配慮をお願いいたします。

例) データ取り込みは、必ず複数回行い平均を取る。

取り込みミスと思われるデータは無効にする判断をさせる。

疑義が生じた場合、再度取り込みをする。上記内容を組み合わせる等。

We would like you to take the mentioned below into consideration in your software to minimize influence of non-reproducible noise and failed data from the sensor which might occur by any chance.

Ex.) Getting data from the sensor should be conducted plural times, then take an average.

Suspected data must be judged that they are invalid, and then get them again.

Combination of these actions, etc.

6.4 本製品はその製品構造上、使用状態において、本体ケースの圧縮及びツマミ部への回転動作以外の無理な力(押し等)を加えますと、それらの変形により電気的特性の変化、及び回転トルクの増大、寿命低下、機械的破損が生じる場合があります。

従いまして、ツマミには回転動作以外の力が加わらないよう注意をお願い致します。

又、やむを得ずツマミに過大な側圧がかかる場合には、ツマミへの嵌合シャフトが支軸となるような取り付けをお願いいたします。

Because of the construction of this product, an excessive stress, pressure to the body, or pressure or excessive force other than rotation to the hollow shaft portion may cause performance degradation in electrical, mechanical, life, or feeling.

To prevent this, please avoid any stress, pressure or force other than rotational one to the hollow shaft

If actuation knob (provided by user) may be subjected to an excessive side force, the mating shaft must be supported with robust bearing mechanism so that the hollow shaft is free from such force.

NG

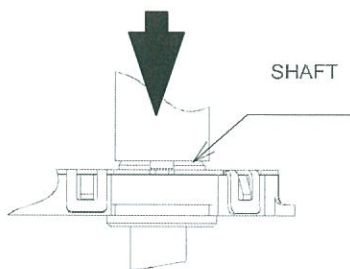

ALPS ELECTRIC CO., LTD.

APPD.	CHKD.	DSGD.
CENG2(G)	CENG2	CENG2
Apr. 12' 16	Apr. 12' 16	Apr. 12' 16
S.Urushihara	T.Ohara	Y.Shimizu

TITLE	規格書 SPECIFICATIONS
DOCUMENT NO.	5RD6R1-A19
	(7/9)

CLASS NO.

TITLE

ROTARY SENSOR

6.5 ツマミは 360° 回転しますが、抵抗体の構造上、下図範囲(40°)における回転寿命は著しく少なくなっております。従いまして、実使用時において下図範囲が駆動される使い方はお避けください。取付け時等における駆動は 100 回程度であれば問題ありません。
The hollow shaft of this product rotates 360 degrees (endless). However the below shown area (40 degree) is not durable because of the construction. In application, therefore, please do not use the shown area as regular operation. Up to 100 cycles actuation at the area for shutting is allowed.

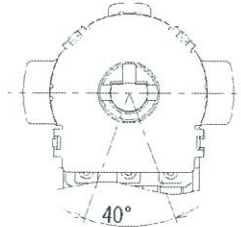

6.6 製品取付け時の注意 Attention when product is installed
製品取付け時、端子の上下方向へ負荷が加わりますと、カシメ部を損傷する恐れがあります。端子も変形しますのでご注意ください。
If the over load to the terminal is added when the products is installed, the rivet might be damaged. Moreover, please care the deformed of the terminal.

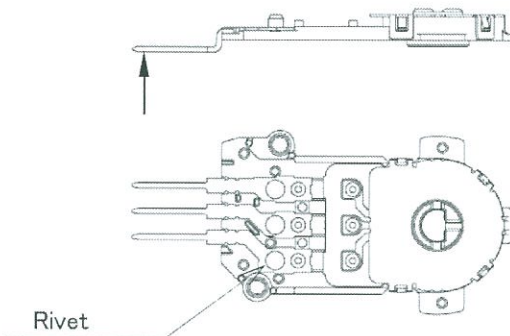

6.7 リニアリティの判定について About the judgment of linearity
リニアリティの判定に疑義が生じた場合は、互いに合意された専用測定ゲージにより基準点出力を測定します。その結果を測定機での測定結果と照合し、測定機の精度を確認した上でリニアリティの可否判定を行うこととします。専用ゲージは互いに合意されたものとします。
The reference point output is measured with a special gauge when there is a doubt in the judgment of linearity. After it is collated with the result of the measuring instrument and the accuracy of the measuring instrument is confirmed, pass or fail is judged. The special gauge is approved by each other.

6.8 当製品は密閉構造ではありませんので、使用環境によって外部ガスが製品内部に侵入し接点障害を起こす場合があります。同一セット内に以下の様な部材を使用しないで下さい。
・硫化、酸化ガスを発生する部材(例:ゴム材,接着材,合板,潤滑剤,梱包材)
・低分子シロキサンガスを発生する部材(例:シリコン系ゴム,潤滑剤,接着剤)
As this product does not have hermetical structure, it is possible gas from outside get inside of product and may cause contact failure depends on using environment. Please avoid using following materials.
If you have to use any of material in parentheses , please pay special attention and confirm it does not influence to products through tests under actual using conditions.
-materials which may generate sulfide gas or oxidized gas.
(rubber , glue , adhesive , plywood , packaging material)
-materials which may generate low-molecular-weight siloxane gas.
(silicone base rubber , lubricant ,glue)

ALPS ELECTRIC CO., LTD.

					APPD. CENG2(G) Apr. 12' 16 S.Urushihara	CHKD. CENG2 Apr. 12' 16 T.Ohara	DSGD. CENG2 Apr. 12' 16 Y.Shimizu	TITLE 規格書 SPECIFICATIONS
SYMB	DATE	APPD	CHKD	DSGD	DOCUMENT NO.			5RD6R1-A19 (8/9)

Confidential

CLASS NO.	TITLE
	ROTARY SENSOR

- 6.9 高湿度環境下,又は結露する環境下,液体が製品にかかる環境下では、端子間の電流リークが発生する恐れがありますのでご使用にならないで下さい。
Please not to use this product under the atmosphere with high humidity, with possibility of dew condensation or of direct splash of liquid. Because it may cause leak between terminals.
- 6.10 使用温度範囲の上限、下限付近で長期間の連続使用はできません。
動作寿命の規定は常温 15°C~35°C、常湿 25%~85%の環境条件に限ります。
使用温度範囲の上限、下限付近で長期間の連続動作を行う場合は、機種毎に仕様規定が可能かどうか、確認が必要になります。
This product can't be continuously used under high operating temperature or low operating temperature specified in this document. Unless otherwise specified, the durability is specified only under normal conditions, temperature 15 to 35 degree Celsius and related humidity 25 to 85%.
When this product is operated at temperature near from upper or lower limit of operating temperature range, feasibility must be examined by each product specification.
- 6.11 製品本体を規定の取付面まで挿入して水平になるように取付けて下さい。
水平にならないまま取付けますと、動作不良の要因となります。
Insert these products to the specified mounting surface and mount them horizontally.
If not mounted horizontally, these products will malfunction.
- 6.12 塵埃が多い環境で使用されますと塵埃が開口部から入り出力不良や動作不良の原因となることがありますのでセット設計時に予めご配慮ください。
If this product is used under dusty conditions, dust or debris may get inside of product from openings and possible to cause output failure or malfunction.
Please consider protections against dust when surrounding parts of the product are designed.

ALPS ELECTRIC CO., LTD.

					APPD.	CHKD.	DSGD.	TITLE
					CENG2(G)	CENG2	CENG2	規格書 SPECIFICATIONS
					Apr. 12' 16	Apr. 12' 16	Apr. 12' 16	DOCUMENT NO.
SYMB	DATE	APPD	CHKD	DSGD	S.Urushihara	T.Ohara	Y.Shimizu	5RD6R1-A19 (9/9)

ME-CHECK: 4 ST-CHECK: 5 PE-CHECK: 6

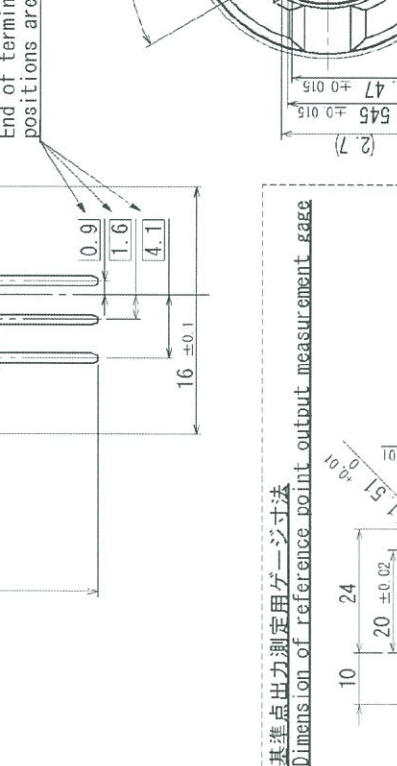
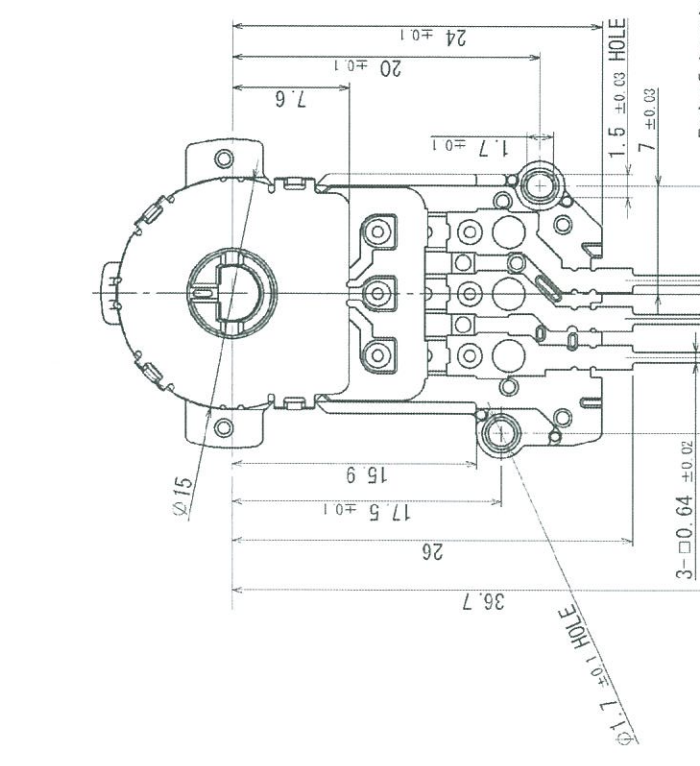
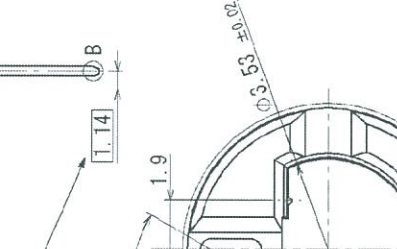
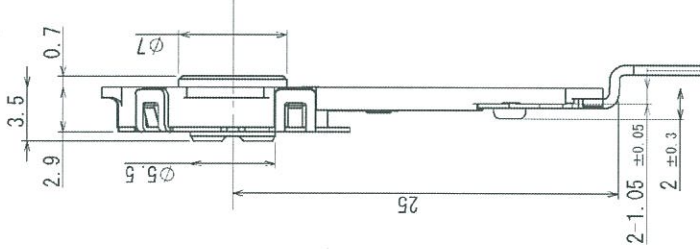
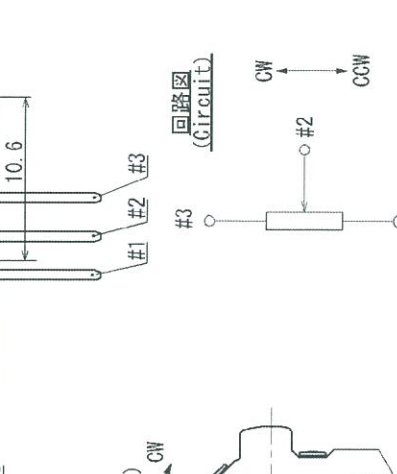
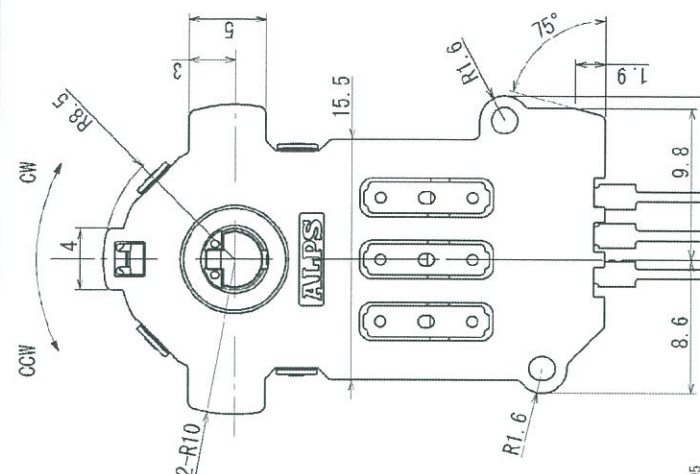

基準出力測定用ゲージ寸法
Dimension of reference point output measurement gage

PART NO.	NAME	SPEC	MATERIAL	FINISH	NH Project
DSGD	M. SUZUKI	Apr. 23. 2015	SCALE	NO.	
CHKD	T. OHARA	Apr. 23. 2015	3:1		
APPD	T. SASAKI	Apr. 23. 2015	UNIT	mm	
DATE	2014-11-20	S. U. I. O. T. E.	FEED BACK SENSOR	(1/1)	
SYME	OR	2014-11-20	RD6GR404		

ALPS ELECTRIC CO., LTD.

Confidential

SW

X-ON Electronics

Largest Supplier of Electrical and Electronic Components

Click to view similar products for [Board Mount Motion & Position Sensors](#) category:

Click to view products by [ALPS](#) manufacturer:

Other Similar products are found below :

[6SS4](#) [F02008062](#) [9970-090-9J-SA](#) [IPS2200BI1R](#) [NJL5820R-TE4](#) [AS5270B-HMFM](#) [IPS2200BI1W](#) [G-MRCO-057](#) [MB060-N-221-A02](#)
[MB090-N-221-A02](#) [USEQMSKL221600](#) [EVW-ADF001B14](#) [MLX90316KDC-BDG-100-RE](#) [AMN33111J](#) [ZSBG446671](#) [MTS-360-1A-](#)
[C0000-ERA360-05E](#) [AMN11111](#) [AMN24112](#) [AMN31111](#) [AMN31112](#) [AMN34112](#) [AMN34111](#) [EKMB1303111K](#) [EKMB1293112](#)
[ZSBG323671](#) [RBS130100](#) [RBS130200](#) [EKMC1605111](#) [EKMB1104111](#) [EKMB1305111K](#) [EKMC1604112](#) [EKMB1305112K](#)
[EKMB1205111](#) [EKMB1205112](#) [EKMB1304113K](#) [EKMB1104113](#) [EKMB1105111](#) [EKMC1604111](#) [EKMB1105112](#) [EKMB1305113K](#)
[EKMB1204113](#) [EKMB1105113](#) [EKMB1205113](#) [EKMB1304112K](#) [EKMB1304111K](#) [EKMC1606111](#) [G-MRCO-052](#) [OKY3062-2](#)
[OKY3062-4](#) [OKY3062-5](#)