

CLASS.NO.	TITLE	
	HEAD LIGHT SENSOR SPECIFICATION	

1. General

1-1 Scope

This specification applies to sliding type potentiometer with carbon composition resistor, used as a HEAD LIGHT LEVEL SENSOR for motor vehicle.

1-2 Standard atmospheric conditions

Unless otherwise specified, the standard range of atmospheric conditions for making measurements and tests are as follows:

Ambient temperature : 5 to 35°C  
 Relative humidity : 45 to 85%  
 Air pressure : 86 to 106kPa

If there is any doubt about the results, measurement shall be made within the following limits.

Ambient temperature : 20±2°C  
 Relative humidity : 60 to 70%  
 Air pressure : 86 to 106kPa

1-3 Operating temperature range : -40±2°C to +105+5°C

1-4 Storage temperature range : -40±2°C to +105+5°C

2. Appearance and Dimensions

2-1 Appearance

The potentiometer shall have no damage and not have any excessive rust, crack, split, poor plating and discolor in any portion.

2-2 Dimensions

The physical dimensions of the potentiometer shall be in accordance with the product drawing.

3. Electrical characteristics

No.	Item	Conditions	Specifications	
3-1	Nominal total resistance and tolerance	Measurement shall be made by the resistance between terminal 1 and 3.	3 kΩ ± 20 %	
3-2	Rated voltage		D.C. 13.5 V ± 0.1V	
3-3	Operating voltage endurance		D.C. 9 to 18 V	
3-4	Resistance taper	Point	Position	
		A and B	Point A and B refer to the product drawing	
		A'	9.1% from the A point.	2.99±0.5 mm
		B'	6.07 mm from the A' point.	85±2%
		A	Refer to the product drawing	2 % or less
		B	Refer to the product drawing	98 % or more
3-5	Linearity	The linearity shall be defined the percentage of variation on traveled between point <u>A'</u> and <u>B'</u> compared with the ideal straight line which is chained outputs at the point <u>A'</u> and <u>B'</u> on each product. Measurement speed : At 1mm/sec. Lever travel	±1% (Output wave form See fig.1)	

					<b>ALPS ELECTRIC CO., LTD.</b>			
					APPD.	CHKD.	DSGD.	TITLE
					DESIGN 06.5.-9 IKNOUE	DESIGN 06.5.-9 TAMADA	SPECIFICATIONS	DOCUMENT NO.
SYMB.	DATE	APPD.	CHKD.	DSGD.				5RD712A009M

CLASS.NO.	TITLE
	HEAD LIGHT SENSOR SPECIFICATION

No.	Item	Conditions	Specifications
3-6	Hysteresis	This item shall be measured by using of ALPS measurement equipment, because it is susceptible to measuring conditions. Measurement speed : At 1mm/sec. Lever travel	±1%
3-7	Insulation resistance	The voltage of 50 V D.C. shall be applied between individual terminals and case for 1 min.	100 MΩ or more
3-8	Dielectric strength	The voltage of 124 V A.C. shall be applied between individual terminals and case for 1 min.	Without damage to parts arcing of breakdown.
3-9	Overvoltage resistance	The voltage of 32 V D.C. shall be applied between terminals 1 and 3 for 60 sec.	Without damage to parts arcing of breakdown.

4. Mechanical characteristics



Mechanical characteristics shall be in accordance with the document No. 5RD7001-300M attached.

5. Endurance characteristics

No.	Item	Conditions	Specifications
5-1	Specified characteristics after tests.	5-1-1 The measurement shall be made , after 20,000 actuating cycles.	Linearity : ± 1.5 % Hysteresis : ± 1.5 % Operating force : 2N MAX.
		5-1-2 The measurement shall be made , after 100,000 actuating cycles.	Linearity : ± 2 % Hysteresis : ± 2 % Operating force : 2N MAX.
			Total resistance is specified individually in each test
5-2	Endurance with load	The lever of potentiometer shall be sliding to 20,000 actuating cycles and 100,000 actuating cycles at a speed of 0.5~30 mm/s. with specified voltage loaded. ( 1 cycle is 1 go and return ) Sliding of travel: Per 1 cycle with over 90 % sliding of travel range . The measurement shall be made with the process Below.	Total resistance : Nominal total resistance ±35%  Except above items, refer to the 5-1 items
5-3	Cold	Temperature : - 40 ± 2°C Time : 96 ± 4 hours and stand in a room of normal temperature and humidity for 1 hour without load.	Total resistance : Nominal total resistance ± 40 % Except above items, refer to the 5-1-1 items

					<b>ALPS ELECTRIC CO., LTD.</b>			
					APPD.	CHKD.	DSGD.	TITLE
					DESIGN '06. 5. -9 TKNOUE	DESIGN '06. 5. -9 TAMADA	SPECIFICATIONS	
							DOCUMENT NO.	
SYMB.	DATE	APPD.	CHKD.	DSGD.			5RD712A009M	

CLASS.NO.		TITLE		
		HEAD LIGHT SENSOR SPECIFICATION		
No.	Item	Conditions	Specifications	
5-4	Dry heat	Temperature : +105 +5°C Time : 96 ± 4 hours and stand in a room of normal temperature and humidity for 1 hour without load.	Total resistance : Nominal total resistance +25/-50% Except above items, refer to the 5-1-1 items	
5-5	Damp heat	Temperature : +40 ± 2°C Humidity : 90 - 95% R.H. Time : 96 ± 4 hours and stand in a room of normal temperature and humidity for 1 hour without load.	Total resistance : Nominal total resistance +55/-25% Except above items, refer to the 5-1-1 items	
5-6	Change of temperature	Temperature : See fig.2. Cycle : 5 successive change of temperature Cycles, and stand in a room of normal temperature and humidity for 1 hour without load.	Total resistance : Nominal total resistance ± 40 % Except above items, refer to the 5-1-1 items	
		Fig.2.		
		Step	Temperature	Duration
		1	-40 ± 2°C	30 Min
		2	Standard atmospheric conditions	10 to 15 Min
3	105 + 2°C	30 Min		
4	Standard atmospheric conditions	10 to 15 Min		
5-7	Vibration	Frequency range : 10 to 55 Hz and return to 10Hz Amplitude : 1.5mm Sweep time : 1min Total time : 2h x 3directions	Total resistance : Nominal total resistance ± 25 % Except above items, refer to the 5-1-1 items	
5-8	Resistance to soldering heat	(1) Dip soldering Soldering temperature : 260°C or less Immersion time : 5sec. or less. Printed wiring board : Accordance with the product drawing. Material of the board : One-sided copper clad phenolic board.  Dimensions of component holes in the heat Shut ( printed wiring board ) shall be in accordance with those specified in the product drawing.  (2) Manual soldering Bit temperature of soldering iron: 350°C or less. Application time of soldering : 3sec. or less.	Total resistance : Nominal total resistance ± 25 % Except above items, refer to the 5-1-1 items  There shall be no deformation or cracks in molded part. No excessive abnormality in rotational feeling.	

					<b>ALPS ELECTRIC CO., LTD.</b>			
					APPD.	CHKD.	DSGD.	TITLE
							SPECIFICATIONS	
SYMB.	DATE	APPD.	CHKD.	DSGD.			DOCUMENT NO.	5RD712A009M

CLASS.NO.	TITLE
	HEAD LIGHT SENSOR SPECIFICATION

Fig.1

Output wave form

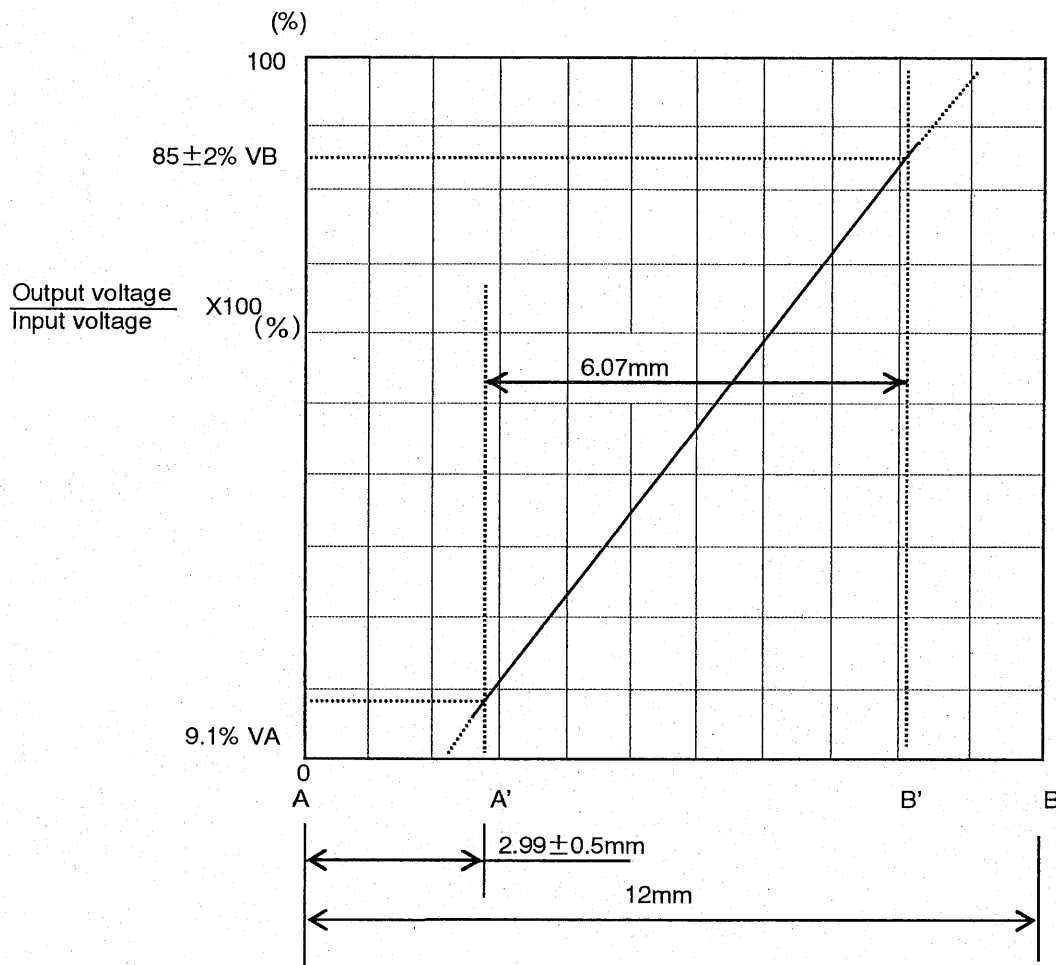

Point A and B : Refer to the product drawing.

					<b>ALPS ELECTRIC CO., LTD.</b>			
					APPD.	CHKD.	DSGD.	TITLE
					DESIGN '06.5.-9 IKNOUE	/	DESIGN '06.5.-9 TAMADA	SPECIFICATIONS
								DOCUMENT NO.
SYMB.	DATE	APPD.	CHKD.	DSGD.				

CLASS No.	Title	LINEAR SENSOR
-----------	-------	---------------

機械的性能 Mechanical characteristics

No.	項目 Item	条件および規格 Conditions or Specifications
1-1	カストローク Lever travel	個別製品組立図による。 Accordance with the product drawing.
1-2	作動力 Operating force	2 N 以下 or less. 測定位置: レバー先端より1mmの位置 測定速度: 10mm / 秒 Operating position : 1 mm from the lever end. Traveling speed : 10 mm/s
1-3	レバーの移動止強度 Lever travel stop strength	しゅう動距離の両末端においてレバー先端より1mmの位置に10Nの静荷重を5秒間加え、著しいがた、及び接触不良を生じないこと。 測定はプリント基板に半田付けし、プリント基板を固定した状態で行う。 但し、縦型形状の製品は、図1の様に製品上部も固定した状態で測定のこと。 A static load of 10 N shall be applied at the point 1 mm from lever end for both end in the direction of lever travel for 5 s, without excessive play or poor contact. The measurement conditions, see Fig.1
1-4	レバーの横押し強度 Side thrust of the lever	レバー先端から1mmの位置に、レバーの移動方向に対して直角方向に10Nの静荷重を5秒間加え、操作部、及び関連部品に変形、破損がないこと。 測定はプリント基板に半田付けし、プリント基板を固定した状態で行う。 但し、縦型形状の製品は、図1の様に製品上部も固定した状態で測定のこと。 A static load of 10 N shall be applied at the point 1 mm from lever end in a direction perpendicular to the axial direction for 5 s, without deformation or breaks in the sliding part and contact part. The measurement conditions, see Fig.1
1-5	レバーの押し引き強度 Thrust and tensile lever	レバーの押し方向及び引張り方向に10Nの静荷重を5秒間加え、レバーのがた、破損、及びしゅう動ムラ等がなく、電気的性能を満足すること。 但し、縦型形状の製品は、図1の様に製品上部も固定した状態で測定のこと。 Thrust and tensile static load of 10 N shall be applied to the potentiometer in the lever direction for 5 s., without damage such as bad sliding and braking or play in the lever. And the electrical characteristics shall be satisfied. The measurement conditions, see Fig.1
1-6	レバーの横振れ Displacement of lever	0.5 mm p-p 以下 or less. レバー先端より3mmの位置に、2Nの静荷重を移動方向に対して直角方向に加え、測定する。 A static load of 2N shall be applied at the point 1 mm from lever end in a direction perpendicular to the axial direction and then the displacement shall be measured at the point 3mm from lever end.
1-7	レバーの傾き及びねじれ Lever inclination and torsion	$\theta$ は $2^\circ$ 以下 $\theta$ shall be $2^\circ$ or less. 
1-8	レバーのセンタスレ Distance from the center of the lever	片側 0.5 mm 以下 枠開口部中心に対するレバーセンタからのスレを片側ごとに測定する。 0.5mm or less on each end. After sliding lever as far as it will go in each direction, the distance from the center of the lever to the center of the case shall be measured at the both ends. 

図1  
Fig.1

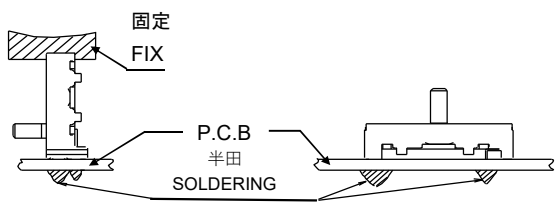

					<b>ALPSALPINE CO., LTD.</b>				
					APPD.	CHKD.	DSGD.	TITLE	規格書 SPECIFICATIONS
					Dec.03.2001 S.Abe	Dec.03.2001 S.Suda	Dec.03.2001 Y.Tamada	DOCUMENT No.	5RD7001-300M (1/1)
ORIGINAL	'99-10-08	T.H	M.A	S.S					
SYMB.	DATE	APPD.	CHKD.	DSGD.					



### 接続インピーダンスについて About impedance

本製品は、図1のように、その出力端子をマイコンのA/Dポートに直接接続して  
 使うことを前提に製作されています。つまり、接続インピーダンスの値はメガオームオーダーを  
 前提とし、センサ内部の接触抵抗をかなり高めに設定しています。  
 よって、図2のような回路でご使用になる場合は、接続インピーダンスが1MΩ以下に  
 ならないように、ご配慮願います。

Since this sensor is designed to use with its output is connected  
 directly to the A/D port, impedance is considered to be mega ohm level,  
 then contact resistance in the sensor is higher. Please refer to fig-1.  
 So when you use it in the circuit like fig-2, please make sure that  
 Impedance should be over than 1M $\Omega$ .

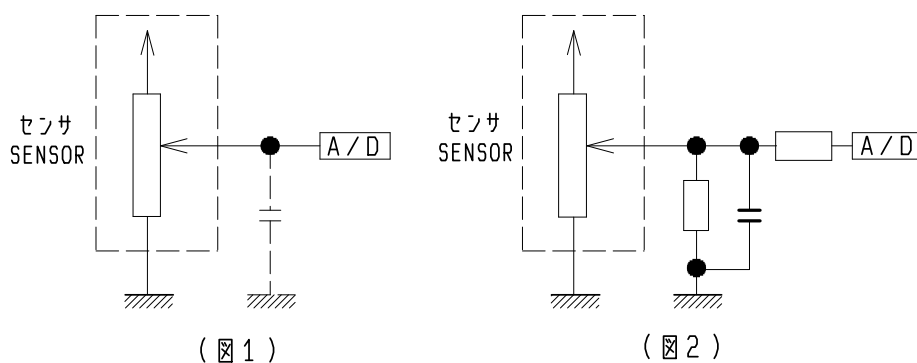

					<b>ALPSALPINE CO.,LTD.</b>			
					APPD.	CHKD.	DSGD.	TITLE
					M-2枚(G)	M-2枚	M-2枚	SPECIFICATIONS
					'12-01-13	'12-01-13	'12-01-13	DOCUMENT NO.
					溝 測	佐々木(亨)	清 水	5RD7001-004
SYMB	DATE	APPD	CHKD	DSGD				

1. ご使用上の注意 Precautions in use

- 1) 当製品は密閉構造ではありませんので、使用環境によって外部ガスが製品内部に侵入し接点障害を起こす場合があります。同一セット内に以下の様な部材を使用しないで下さい。
  - ・硫化、酸化ガスを発生する部材(例:ゴム材,接着材,合板,潤滑剤,梱包材)
  - ・低分子シロキサンガスを発生する部材(例:シリコン系ゴム,潤滑剤,接着剤)

As this product does not have hermetical structure, it is possible gas from outside get inside of product and may cause contact failure depends on using environment. Please avoid using following materials. If you have to use any of material in parentheses, please pay special attention and confirm it does not influence to products through tests under actual using conditions.

  - materials which may generate sulfide gas or oxidized gas.  
(rubber, glue, adhesive, plywood, packaging material)
  - materials which may generate low-molecular-weight siloxane gas.  
(silicone base rubber, lubricant, glue)
  
- 2) 高湿度環境下,又は結露する環境下,液体が製品にかかる環境下では、端子間の電流リークが発生する恐れがありますのでご使用にならないで下さい。
 

Please not to use this product under the atmosphere with high humidity, with possibility of dew condensation or of direct splash of liquid. Because it may cause leak between terminals.
  
- 3) 使用温度範囲の上限、下限付近で長期間の連続使用はできません。
 

動作寿命の規定は常温15℃～35℃、常温25%～85%の環境条件に限ります。  
使用温度範囲の上限、下限付近で長期間の連続動作を行う場合は、機種毎に仕様規定が可能かどうか確認が必要になります。

This product can't be continuously used under high operating temperature or low operating temperature specified in this document. Unless otherwise specified, the durability is specified only under normal conditions, temperature 15°C to 35°C and related humidity 25% to 85%.  
When this product is operated at temperature near from upper or lower limit of operating temperature range, feasibility must be examined by each product specification.
  
- 4) 製品本体を規定の取付面まで挿入して水平になるように取付けて下さい。
 

水平にならないまま取付けますと、動作不良の要因となります。  
Insert these products to the specified mounting surface and mount them horizontally.  
If not mounted horizontally, these products will malfunction.
  
- 5) 塵埃が多い環境で使用されますと塵埃が開口部から入り出力不良や動作不良の原因となることがありますのでセット設計時に予めご配慮ください。
 

If this product is used under dusty conditions, dust or debris may get inside of product from openings and possible to cause output failure or malfunction.  
Please consider protections against dust when surrounding parts of the product are designed.

					<b>ALPSALPINE CO.,LTD.</b>			
					APPD.	CHKD,	DSGD.	TITLE
					Nov.10.2015	Nov.10.2015	Nov.10.2015	ご使用上の注意 (GS) Precautions in use(GS)
					S.Urushihara	T.Sasaki	Y.Shimizu	DOCUMENT No.
SYMB.	DATE	APPD.	CHKD.	DSGD.				C-6 (1/1)



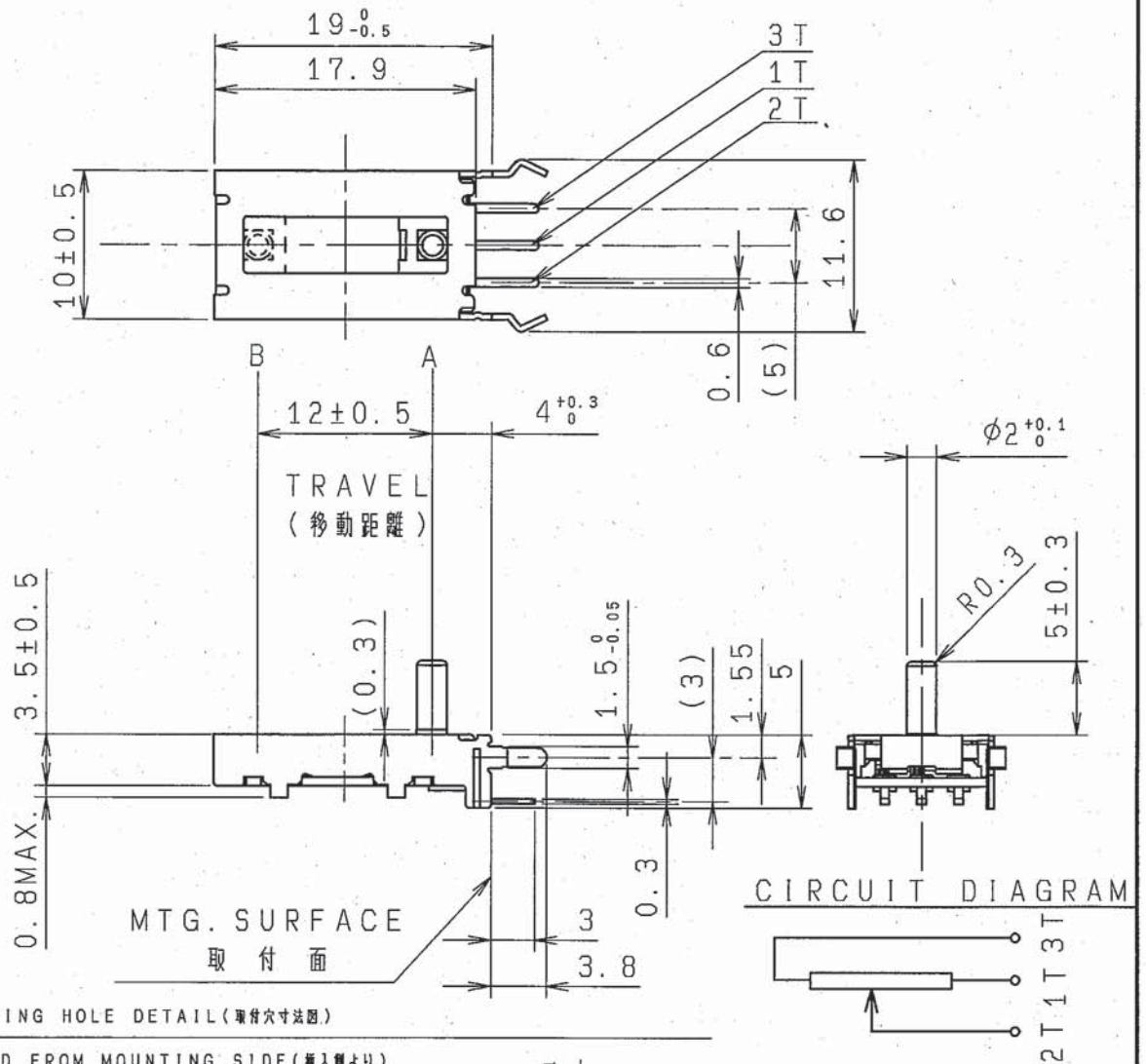

MOUNTING HOLE DETAIL (取付穴寸法図)

VIEWED FROM MOUNTING SIDE (挿入側より)

(RECOMMENDATION 推奨寸法)

DO NOT DESIGN PRINTED WIRING ON THIS AREA.  
パターン禁止範囲

DO NOT DESIGN HOLES EXCEPT FOR MOUNTING HOLES ON THIS AREA.

この範囲内に取付穴以外の穴を開けないこと。

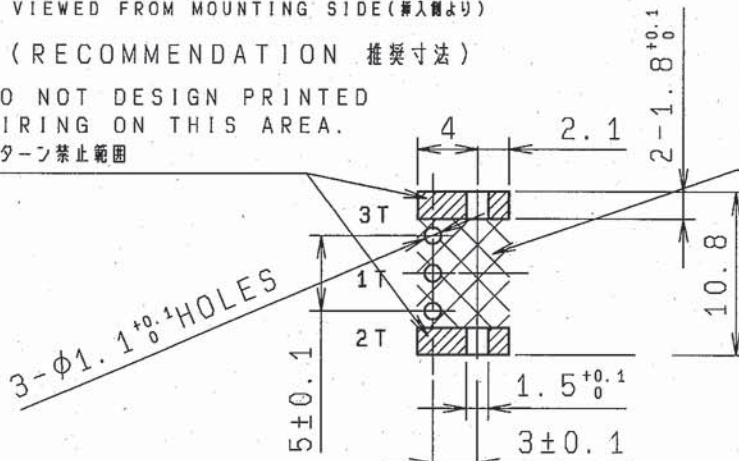

NOTE 1. SNAP PORTION IS DESIGNED BASED ON 1.6mm THICK P.C.B.

1. スナップ部はP.C.B. 板厚1.6mm基準にて設計してあります。

指定なき部分の許容差 TOLERANCES UNLESS OTHERWISE SPEC	
$L \leq 10$	$\pm 0.3$
$10 < L < 100$	$\pm 0.5$
$100 \leq L$	$\pm 0.8$
角度 ANGULAR DIMENSION	$\pm 5^\circ$

PART NO.	NAME	MATERIAL NAME / CODE	FINISH				
<b>ALPS ELECTRIC CO., LTD.</b>							
		DSGD. 1-2G-786083	SCALE				
		Y. TAMADA Mar. 05' 04	2 : 1				
		CHKD.	UNIT				
		S. SUDA Mar. 05' 04		$\text{mm}$			
		APPD.	DOCUMENT NO.				
SYMB	DATE	APPD	CHKD	DSGD	M. ASANO	Mar. 05' 04	RD712A029

OR

## X-ON Electronics

Largest Supplier of Electrical and Electronic Components

*Click to view similar products for [Board Mount Motion & Position Sensors](#) category:*

*Click to view products by [ALPS](#) manufacturer:*

Other Similar products are found below :

[6SS4](#) [F02008062](#) [9970-090-9J-SA](#) [IPS2200BI1R](#) [NJL5820R-TE4](#) [AS5270B-HMFM](#) [IPS2200BI1W](#) [G-MRCO-057](#) [MB060-N-221-A02](#)  
[MB090-N-221-A02](#) [USEQMSKL221600](#) [EVW-ADF001B14](#) [MLX90316KDC-BDG-100-RE](#) [AMN33111J](#) [ZSBG446671](#) [MTS-360-1A-](#)  
[C0000-ERA360-05E](#) [AMN11111](#) [AMN24112](#) [AMN31111](#) [AMN31112](#) [AMN34112](#) [AMN34111](#) [EKMB1303111K](#) [EKMB1293112](#)  
[ZSBG323671](#) [RBS130100](#) [RBS130200](#) [EKMC1605111](#) [EKMB1104111](#) [EKMB1305111K](#) [EKMC1604112](#) [EKMB1305112K](#)  
[EKMB1205111](#) [EKMB1205112](#) [EKMB1304113K](#) [EKMB1104113](#) [EKMB1105111](#) [EKMC1604111](#) [EKMB1105112](#) [EKMB1305113K](#)  
[EKMB1204113](#) [EKMB1105113](#) [EKMB1205113](#) [EKMB1304112K](#) [EKMB1304111K](#) [EKMC1606111](#) [G-MRCO-052](#) [OKY3062-2](#)  
[OKY3062-4](#) [OKY3062-5](#)