

业界最小本体尺寸8.3×5.3×7mm。

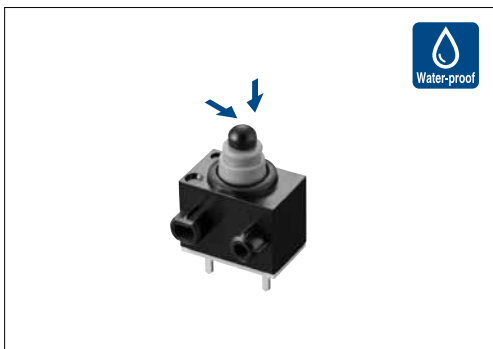

主要规格

项目	规格
最大额定/最小额定 (电阻负载)	0.1A 12V DC / 50μA 5V DC
接触电阻 (初期/寿命后)	500mΩ max. / 1Ω max. (标准型) 500mΩ max. / 3Ω max. (长寿命型)
动作力	1±0.5N
操作寿命	无负载 300,000 cycles (标准型) 1,000,000 cycles (长寿命型)
	负载 300,000 cycles (标准型) 1,000,000 cycles (长寿命型)

产品一览

电路数	接点数	电路	端子形状	主机形状	最小订货单位 (pcs.)		包装规格方式	产品编号		图号
					日本	出口		标准型	长寿命型	
1	1	N.O.	For PC board	双突起	1,755	7,020	A	SPVQ810102	SPVQ830102	1
			Angle	单侧突起				SPVQ810302	SPVQ830302	2
				无突起				SPVQ810402	SPVQ830402	3
			For PC board	单侧突起				SPVQ810502	SPVQ830502	4
			For Lead					SPVQ810602	SPVQ830602	5
			压入	双突起				SPVQ810704	SPVQ830702	6
		N.C.	For PC board	单侧突起				SPVQ810802	SPVQ830802	7
			Angle	单侧突起				SPVQ820102	—	8
				无突起				SPVQ820302	—	9
			For PC board	单侧突起				SPVQ820402	—	3
			For Lead					SPVQ820502	—	4
			压入	双突起				SPVQ820602	—	10
	N.O.	带金属丝 (下部露出)	单侧突起	SPVQ820705	—	11				
			双突起	SPVQ820802	—	7				
			单侧突起	SPVQ821006	—	12				
			双突起	SPVQ850101*	—	13				
			单侧突起	SPVQ850201*	—	14				
			双突起	SPVQ850301*	—	15				
		带金属丝 (左侧露出)	单侧突起	SPVQ850501*	—	16				
			双突起	SPVQ860101*	—	17				
			单侧突起	SPVQ860200*	—	14				
			双突起	SPVQ860301*	—	18				
			单侧突起	SPVQ860500*	—	16				
			双突起							

注

- ※有关带金属丝的产品, 请参考以下规格。
 - 导线长度, 颜色未指定时, 长度: 250mm, 颜色: 设定成红黑中任意一种。
 - 带电线(横拖线)的型号请务必指定回路 (N.O或N.C)。如未指定, 视为N.O回路。
 - 带线圈产品为订单生产
- 本产品不能在水中使用。(防尘/防水性能符合 符合IP67, 但端子部除外)

包装规格

托盘

包装规格方式	包装数 (pcs.)		出口包装箱尺寸 (mm)
	1箱 / 日本	1箱 / 出口包装	
A	1,755	7,020	540×360×270

散装

包装规格方式	包装数 (pcs.)		出口包装箱尺寸 (mm)
	1箱 / 日本	1箱 / 出口包装	
B	400	1,600	555×375×223

外形图

Unit:mm

No.	形状	No.	形状
1	<p>Technical drawing of SPVQ8 model 1. It includes a top view and a side view. Labels include: "The top of the plunger (Measurement position)", "Limit total travel position", "Terminal No. ①-② Operating position", "Free position", "Terminal No. ②", and "Terminal No. ①". Dimensions shown are 6.5, 0.5, 3, 5, 5.3, 7.1, 7.6, 0.8, 2-0.6, 5.08, 8.3, and 92.2.</p>	5	<p>Technical drawing of SPVQ8 model 5. It includes a top view and a side view. Labels include: "The top of the plunger (Measurement position)", "Limit total travel position", "Terminal No. ①-② Operating position", "Free position", "Terminal No. ②", and "Terminal No. ①". Dimensions shown are 6.5, 0.5, 3, 5, 5.3, 7.1, 7.6, 0.8, 2-0.6, 5.08, 8.3, 92.2, 2, 2.6, and 5.3.</p>
2	<p>Technical drawing of SPVQ8 model 2. It includes a top view and a side view. Labels include: "The top of the plunger (Measurement position)", "Limit total travel position", "Terminal No. ①-② Operating position", "Free position", "Terminal No. ②", and "Terminal No. ①". Dimensions shown are 6.5, 0.5, 3, 5, 5.3, 7.1, 7.6, 0.8, 2-0.6, 5.08, 8.3, 92.2, 2.6, 5.7, (2.6), and 5.3.</p>	6	<p>Technical drawing of SPVQ8 model 6. It includes a top view and a side view. Labels include: "The top of the plunger (Measurement position)", "Limit total travel position", "Terminal No. ①-② Operating position", "Free position", "Terminal No. ②", and "Terminal No. ①". Dimensions shown are 6.5, 0.5, 3, 5, 5.3, 7.1, 7.6, 0.8, 2-0.6, 5.08, 8.3, 92.2, 3.8, 3.5, 1.8, 1.2, 2.2, 4.08, 2.2, and 5.3.</p>
3	<p>Technical drawing of SPVQ8 model 3. It includes a top view and a side view. Labels include: "The top of the plunger (Measurement position)", "Limit total travel position", "Terminal No. ①-② Operating position", "Free position", "Terminal No. ②", and "Terminal No. ①". Dimensions shown are 6.5, 0.5, 3, 5, 5.3, 7.1, 7.6, 0.8, 2-0.6, 5.08, 8.3, 92.2, 10.6, 11.1, 2.2, (90°), (2.6), and 5.3.</p>	7	<p>Technical drawing of SPVQ8 model 7. It includes a top view and a side view. Labels include: "The top of the plunger (Measurement position)", "Limit total travel position", "Terminal No. ①-② Operating position", "Free position", "Terminal No. ②", and "Terminal No. ①". Dimensions shown are 6.5, 0.5, 3, 5, 5.3, 7.1, 7.6, 0.8, 2-0.6, 5.08, 8.3, 92.2, 3.8, 3.5, 1.8, 1.2, 2.2, 4.08, 2.2, and 5.3.</p>
4	<p>Technical drawing of SPVQ8 model 4. It includes a top view and a side view. Labels include: "The top of the plunger (Measurement position)", "Limit total travel position", "Terminal No. ①-② Operating position", "Free position", "Terminal No. ②", and "Terminal No. ①". Dimensions shown are 6.5, 0.5, 3, 5, 5.3, 7.1, 7.6, 0.8, 2-0.6, 5.08, 8.3, 92.2, 11.1, 11.6, 5.3, and 92.2.</p>	8	<p>Technical drawing of SPVQ8 model 8. It includes a top view and a side view. Labels include: "The top of the plunger (Measurement position)", "Limit total travel position", "Terminal No. ①-② Operating position", "Free position", "Terminal No. ②", and "Terminal No. ①". Dimensions shown are 6.5, 0.5, 3, 5, 5.3, 7.1, 7.6, 0.8, 2-0.6, 5.08, 8.3, 92.2, 2.2, 0.8, 0.31, 2, 2.6, 1.8, 5.3, 5.6, and Bend base.</p>

检测

滑动

按动

旋转

电源

切换式

通用型

防水型

急速切换型

外形图

Unit:mm

No.	形状	No.	形状
9	<p>Technical drawing of model 9. Front view shows a cylindrical component with two terminals labeled Terminal No. ① and Terminal No. ②. Dimensions include 6.5, 0.5, 3, 2-0.6, 5.08, 8.3, 0.2, 0.2, 5.4, 7.1, 7.6, 5.7, 0.4, 2.6, 2, 5.3, and 2.6. Labels include 'The top of the plunger (Measurement position)', 'Limit total travel position', 'Terminal No. ①-② Operating position', and 'Free position'.</p>	12	<p>Technical drawing of model 12. Front view shows a cylindrical component with two terminals labeled Terminal No. ① and Terminal No. ②. Dimensions include 6.5, 3, 0.4, 0.2, 2.2, 5.4, 7.1, 7.6, 3.7, 8.3, 0.31, 2.2, 0.8, 2.6, 2, 5.6, 1.8, and 5.3. Labels include 'The top of the plunger (Measurement position)', 'Limit total travel position', 'Terminal No. ①-② Operating position', and 'Free position'. A side view shows a 'Bend base'.</p>
10	<p>Technical drawing of model 10. Front view shows a cylindrical component with two terminals labeled Terminal No. ① and Terminal No. ②. Dimensions include 6.5, 0.5, 3, 2-0.6, 5.08, 8.3, 0.2, 0.2, 5.4, 7.1, 7.6, 2.6, and 5.3. Labels include 'The top of the plunger (Measurement position)', 'Limit total travel position', 'Terminal No. ①-② Operating position', and 'Free position'.</p>	13	<p>Technical drawing of model 13. Front view shows a cylindrical component with two terminals labeled No. ② (Red) and No. ① (Black). Dimensions include 8.3, 11.4, 6.5, 3, 1.5, 2.2, 8.3, 7.1, 7.6, 5.3, 2.6, 2, 5.3, and 5.3. Labels include 'The top of the plunger (Measurement position)', 'Limit total travel position', 'Terminal No. ①-② Operating position', and 'Free position'. A side view shows a 'Bend base' and the part number AVSS0.3f.</p>
11	<p>Technical drawing of model 11. Front view shows a cylindrical component with two terminals labeled Terminal No. ① and Terminal No. ②. Dimensions include 6.5, 0.5, 3, 2-0.6, 4.08, 8.3, 0.2, 0.2, 5.4, 7.1, 7.6, 3.8, 3.5, 1.8, 1.2, 2.2, 2.2, 2.6, 2±0.1, and 5.3. Labels include 'The top of the plunger (Measurement position)', 'Limit total travel position', 'Terminal No. ①-② Operating position', and 'Free position'.</p>	14	<p>Technical drawing of model 14. Front view shows a cylindrical component with two terminals labeled No. ② (Red) and No. ① (Black). Dimensions include 8.3, 11.4, 6.5, 3, 1.5, 2.2, 8.3, 7.1, 7.6, 0.8, 5.3, 0.8, 2.6, 2, 5.3, and 5.3. Labels include 'The top of the plunger (Measurement position)', 'Limit total travel position', 'Terminal No. ①-② Operating position', and 'Free position'. A side view shows a 'Bend base' and the part number AVSS0.3f.</p>

检测
滑动
按动
旋转
电源
切换式
通用型
防水型
急速切换型

外形图

Unit:mm

No.	形状	No.	形状
15		17	
16		18	

电路图

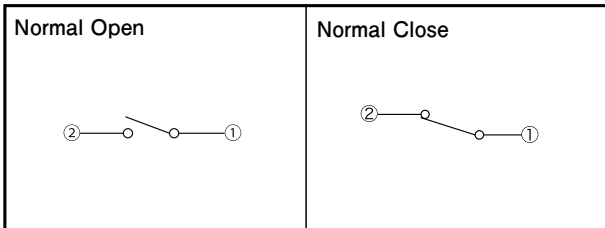

■ 压接端子 (N.O.) 的推荐组装端子形状

Unit:mm

形状

SPVQ811006, SPVQ831002

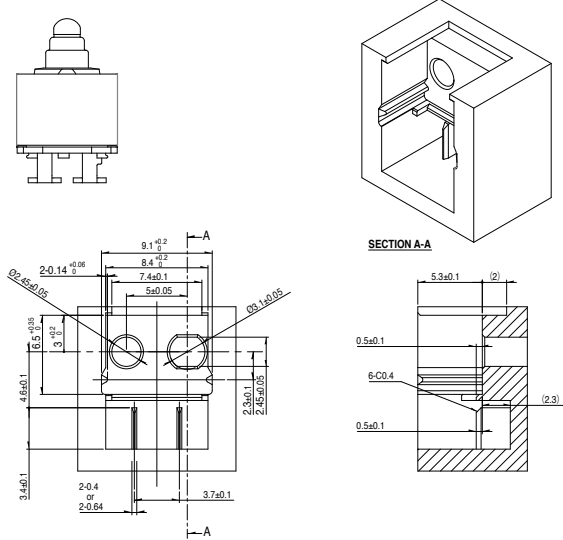









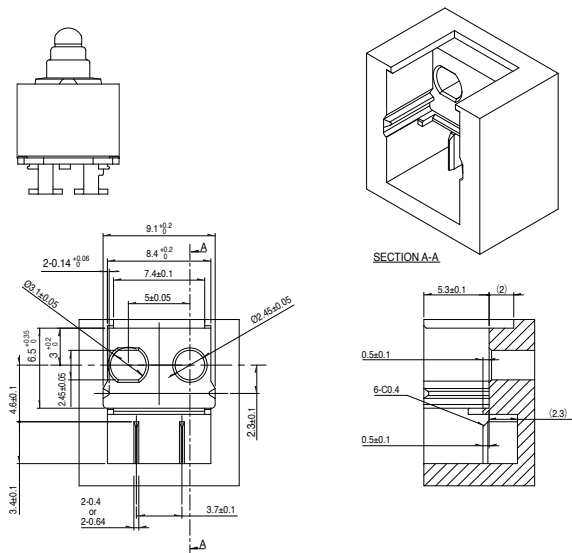

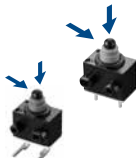
■ 压接端子 (N.C.) 的推荐组装端子形状

Unit:mm

形状

SPVQ821006



系列		防水型			急速切换型	
		SPVQ8	SPVQA	SSCN	SPVQ9	SPVQC
照片						
动作形式		2 方向				
外形尺寸 (mm)	W	8.3	15.2	13	15.4	15.4
	D	5.3	6.4	5	8.4	7.4
	H	6.5	7.95	15	7.5	
使用温度范围		-40°C to +85°C				
车用产品		●	●	●	●	●
生命周期						
电路数 / 接点数		1/1	1/1 1/2	1/2	2/2	
最大额定 (电阻负载)		0.1A 12V DC			50mA 26V DC	50mA 18V DC
最小额定 (电阻负载)		50μA 5V DC		100μA 5V DC	50μA 5V DC	
耐久性	无负载寿命	300,000cycles 1Ω max. or 1,000,000cycles 3Ω max.	300,000cycles 1Ω max.	100,000cycles 1Ω max.	300,000cycles 200mΩ max.	—
	负载寿命 最大额定 (电阻负载)	300,000cycles 1Ω max. or 1,000,000cycles 3Ω max.	300,000cycles 1Ω max.	100,000cycles 1Ω max.	300,000cycles 200mΩ max.	
电性能	初期接触电阻	500mΩ max.			75mΩ max.	
	绝缘电阻	100MΩ min. 500V DC				100MΩ min. 250V DC
	耐电压	500V AC for 1minute				250V AC for 1minute
机械性能	端子强度	3N for 1minute (端子型产品) Wire strength 30N for 1minute (with wire)	3N for 1minute			
	操作部强度	20N		10N	20N	
耐环境性能	耐寒性能	-40°C 500h				
	耐热性能	85°C 500h				
	耐湿性能	60°C, 90 to 95% RH 500h				
动作力		1±0.5N		2N max.	1±0.5N	
页		55	60	63	64	65

检测开关焊接条件 ······ 66

使用检测开关时的注意事项 ······ 67

注

表中的 ● 符号表示适用于系列内的全部产品。

回流方式的参考举例

1. 加热方式远红外线加热的上下加热方式。
2. 温度测量方式用 $\phi 0.1 \sim \phi 0.2$ 的CA (K) 或CC (T) 进行测量。在焊接的连接部位置 (铜箔面) 测量, 固定方式使用耐热载带。
3. 温度分布

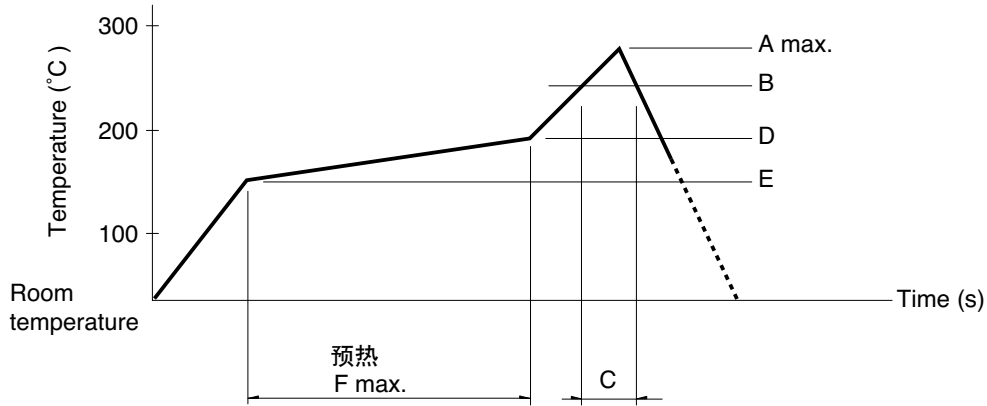

系列 (回流型)	A (°C) 3s max.	B (°C)	C (s)	D (°C)	E (°C)	F (s)
SPPB	250	230	40	180	150	120
SPVE	260		40			
SPVL						
SPVM						
SPVN						
SPVR						
SPVS						
SPVT						
SSCM						
SSCQ						
SPVQC	250					

注

1. 上述条件, 为印刷电路板的零部件表面的温度。根据电路板的材质, 大小, 厚度等, 电路板温度和开关表面温度会有很大的不同, 关于开关表面温度, 也请在上述条件内使用。
2. 根据贴面焊槽的种类, 条件不同结果不同, 请事先充分进行确认之后使用。

手工焊接方式的参考举例

项目	焊接温度	焊接时间
SPVS, SPVN, SSPVT, SPVM, SPVR, SPVE, SSCQ, SSCM, SPVL, SSCT, SPVQC	350±5°C	3s max.
SPVQ1, SPVQ3, SPVQ6, SPVQ7, SPVQ8, SPVQ9, SSCN, SPVQA	300±10°C	3+1/0s
SPPB (Reflow)	350±5°C	5s max.
SSCF, SPPB (For Lead, Dip)	350±10°C	3+1/0s

浸焊方式的参考举例

适用于 For PC board 端子型

项目	项目		浸焊	
	预热温度	预热时间	焊接温度	焊接浸渍时间
SSCT, SPVQ1, SPVQ3, SPVQ6, SPVQ7, SPVQ8, SPVQ9, SPVQA	100±10°C	60s max.	260±5°C	5±1s
SPPW8, SPPB	100 °C max.	60s max.	255±5°C	5±1s
SSCF	—	—	260±5°C	5±1s

X-ON Electronics

Largest Supplier of Electrical and Electronic Components

Click to view similar products for [Detector Switches](#) category:

Click to view products by [ALPS](#) manufacturer:

Other Similar products are found below :

[E3S-LS5C4S](#) [SPVQ850300](#) [SPVQ860100](#) [D3DM0005H](#) [D3DM0001E](#) [D3C 1003E](#) [D3DM0003A](#) [SPVQ810501](#) [SPVQ351400](#)
[SPVT230103](#) [SPVQ351100](#) [SPVQ351900](#) [SPVQ352000](#) [SPVT120103](#) [SPVT220103](#) [SPVT210104](#) [SPVT230202](#) [SPVQE10100](#)
[SPVQ350300](#) [SPVQ351300](#) [SPVQ351500](#) [SPVT240103](#) [SPVT140104](#) [SPVQ352100](#) [SPVQ350600](#) [SPVQ350700](#) [SPVQ350900](#)
[SPVQ351700](#) [SPVQ351800](#) [SPVQ830502](#) [ESE-13V05D](#) [ESE-31R11T](#) [ESE-23F101](#) [ESE-13V01D](#) [ESE-13V01C](#) [ESE-13V01A](#) [ESE-13H01B](#) [ESE-11MH1T](#) [ESE-11MH2T](#) [ESE-11MV1](#) [ESE-31L11T](#) [HDS001R](#) [SPVL110102](#) [ESE-11MV1T](#) [ESE-13V01B](#) [ESE-23J101](#)
[SPPW811200](#) [461011220101](#) [ESE-58R61B](#) [SPVQ361300](#)