

NOTES:

1. MATERIALS AND FINISHES:
 BODY - BRASS, SILVER PLATING
 CLAMP NUT - BRASS, SILVER PLATING
 BRAID CLAMP - BRASS, SILVER PLATING
 GASKET - SILICONE RUBBER
2. PACKAGING:
 A. QUANTITY: SINGLE PACK
 B. MARKING: BAG TO BE MARKED
 "AMPHENOLRF, 1075, AND DATE CODE"
3. RECOMMENDED CABLE ASSEMBLY INSTRUCTIONS
 A. TRIM CABLE AS SHOWN
 B. SLIDE CLAMP NUT, WASHER AND GASKET OVER CABLE.
 C. SLIDE BRAID CLAMP OVER BRAID UP TO JACKET OF CABLE. FOLD BRAID BACK OVER CLAMP MAKING SURE BRAID IS EVENLY DISTRIBUTED OVER THE SURFACE OF THE CLAMP.
 D. INSERT THE CABLE INTO THE CONNECTOR, SCREW NUT INTO BODY WITH WRENCH UNTIL MODERATELY TIGHT.

4 SHOWS CABLE ENTRY DIMENSIONS.

1075		REVISIONS			
DRAWING NO.	REV	DESCRIPTION	DATE	ECO	APPR
THIRD ANGLE PROJ.	A	REDRAWN NO CHANGE	8-25-53	--	--
	F	SEE SHEET-1	3-26-74	20260	EVH
	G	REDRAWN IN PRO E	7/14/11	48363	RAK
	H	ADD STAMPING TO COD	11/15/11	48803	CPM

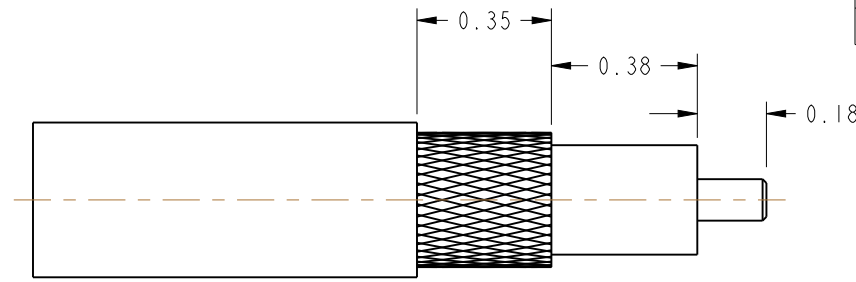

SCALE 2.000
RECOMMENDED
CABLE STRIPPING DIMENSIONS

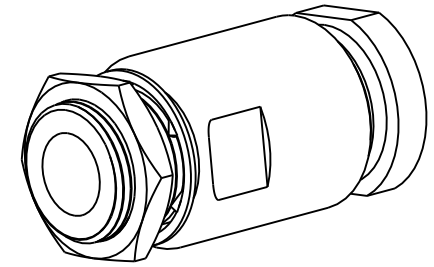

SCALE 1.500

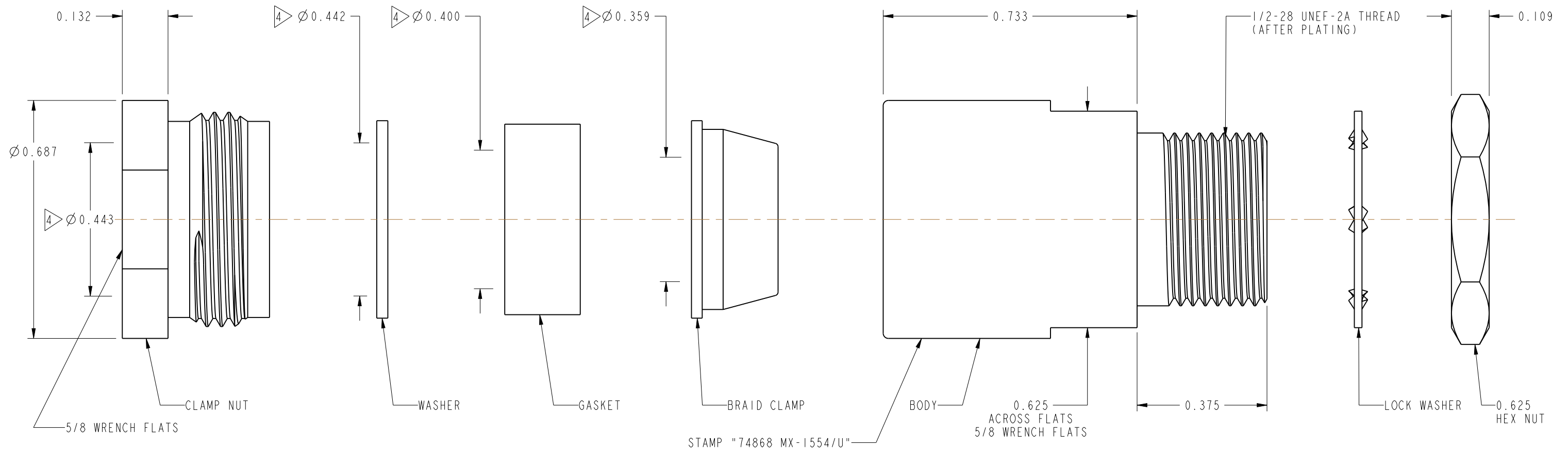

CUSTOMER OUTLINE DRAWING
 ALL OTHER SHEETS ARE FOR INTERNAL USE ONLY

UNLESS OTHERWISE SPECIFIED, DIMENSIONS ARE IN INCHES AND TOLERANCES ARE: 2 PLACE DECIMAL ±.015 (0,381 mm) 3 PLACE DECIMAL ±.005 (0,127 mm) ANGLES ± 1°	MATERIAL	DRAWN	DATE	TITLE	Amphenol RF Danbury, CT, USA Tainan, Taiwan Shenzhen, China www.amphenolrf.com		
	SEE NOTES	ABHAYA KISHORE	03-Dec-10			COAX CABLE TERMINATION SINGLE HOLE MOUNTING FOR RG-8/U	
NOTICE - These drawings, specifications, or other data (1) are, and remain the property of Amphenol Corp. (2) must be returned upon request; and (3) are confidential and not to be disclosed to any person other than those to whom they are given by Amphenol Corp. The furnishing of these drawings, specifications, or other data by Amphenol Corp., or to any other person to anyone for any purpose is not to be regarded by implication or otherwise in any manner licensing, granting rights or permitting such holder or any other person to manufacture, use or sell any product, process or design, patented or otherwise, that may in any way be related to or disclosed by said drawings, specifications, or other data.	REFERENCE	ENGINEER	DATE	SCALE: 3.5:1	SHEET 2 OF 2		
		K. CAPOZZI	1/5/11				
			CAD FILE		CODE ID	DWG SIZE	DRAWING NO.
				74868	B	1075	H

X-ON Electronics

Largest Supplier of Electrical and Electronic Components

Click to view similar products for [RF Terminators](#) category:

Click to view products by [Amphenol](#) manufacturer:

Other Similar products are found below :

[M390303-02N](#) [M39030/3-04S](#) [M39030/3-09S](#) [TNG1-9-78-D3](#) [TNA2-50](#) [TNG1-6-78](#) [TNH1-1-50](#) [R404280000](#) [TNGFL1-1-78](#) [R4042N5000](#)
[R404518000](#) [53S1RR-001N3](#) [142275](#) [56S1RR-001N4](#) [18S15R-0.5E3](#) [65_BNC-50-0-7/133_NE](#) [71S1RR-001N4](#) [02S17R-001D3](#)
[R404240120](#) [R404260000](#) [HT-10-2](#) [M39030/3-04N](#) [TNA1-6-50](#) [131-3801-811](#) [TNA1-1-50](#) [65_N-50-0-1/133_NE](#) [65002_N-50-1/122_NE](#)
[65_MMCX-50-0-31/111_OE](#) [18K15R-0.5E3](#) [2702702](#) [TRM-2161-M0-35M-02](#) [53S17R-001N3](#) [18S24H-40ML5](#) [TRM-2053-M0-NNN-02](#)
[R404759000](#) [M39030/6-02N](#) [TRM-2080-M0-NNN-07](#) [TRM-2053-MC-NNN-02](#) [M39030/3-03S](#) [SF8012-6009](#) [6701.01.A](#) [65_716-50-0-](#)
[2/003_-E](#) [65_SMB-50-0-1/111_NE](#) [M39030/3-12N](#) [M39030/5-06N](#) [82-5722-RFX](#) [8018-6174](#) [SF8018-6005](#) [000-46650-51RFX](#) [082-6693](#)