

NOTES:

1. MATERIALS AND FINISHES:
 BODY, CLAMP NUT, BRAID CLAMP & BUSHING - BRASS, NICKEL PLATING
 CONTACT - BeCu, SILVER PLATING
 INSULATORS - PTFE, NATURAL
 GASKET - SILICONE RUBBER, RED
2. ELECTRICAL:
 A. IMPEDANCE: 50 OHM
 B. FREQUENCY RANGE: DC - 4 GHz
 C. DIELECTRIC WITHSTANDING VOLTAGE: 1500 VRMS, MIN.
3. MECHANICAL:
 A. DURABILITY: 500 CYCLES MIN.
 B. TEMPERATURE RANGE: -40° C TO +85° C
4. PACKAGING:
 A. QUANTITY: SINGLE PACK
 B. MARKING: BAG TO BE MARKED
 "AMPHENOL RF, 86425, AND DATE CODE"

5. CABLE ASSEMBLY INSTRUCTIONS:

- A. PLACE CLAMP NUT AND GASKET (WITH 'V' GROOVE TOWARD OPEN END OF CABLE) OVER CABLE.
- B. TRIM CABLE TO RECOMMENDED STRIPPING DIMENSIONS.
- C. PULL BRAID WIRES FORWARD AND TAPER TOWARD CENTER CONDUCTOR PLACE BRAID CLAMP PART THROUGH BRAID AND PUSH BACK AGAINST CABLE JACKET.
- D. FOLD BACK BRAID WIRES. FIT INSULATOR TO CABLE, SOLDER ON CONTACT.
- E. INSERT CABLE AND PARTS TO CONNECTOR BODY. MAKE SURE SHARP EDGE OF BRAID CLAMP SEATS PROPERLY IN GASKET. TIGHTEN NUT.

6. SHOWS CABLE ENTRY DIMENSIONS.

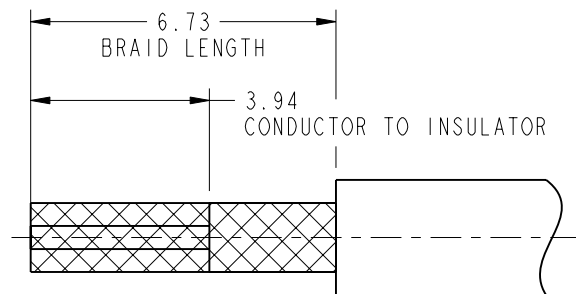

RECOMMENDED CABLE STRIPPING DIMENSIONS

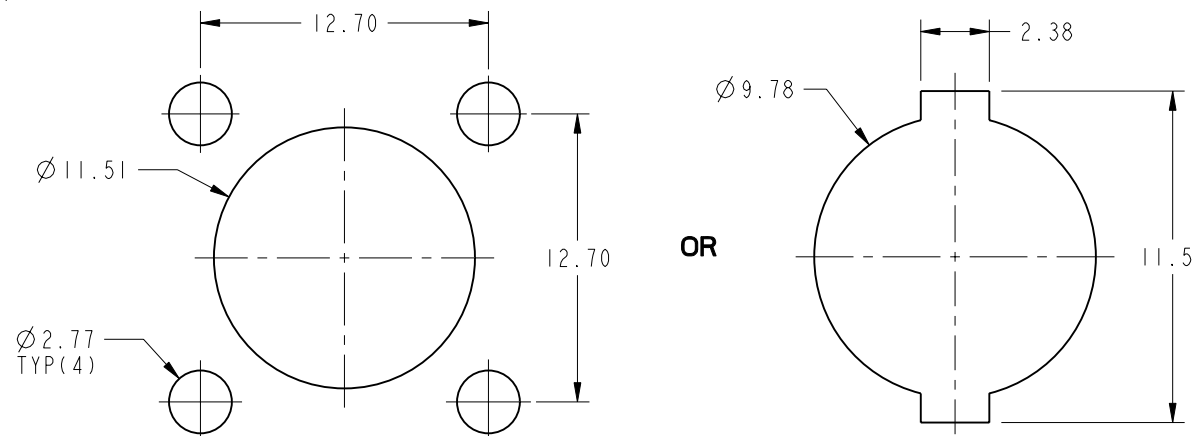

**RECOMMENDED MOUNTING HOLE DIMENSIONS
 MAX. PANEL THICKNESS: 8.70MM**

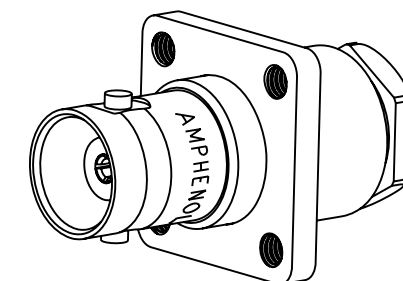

SCALE 1.800

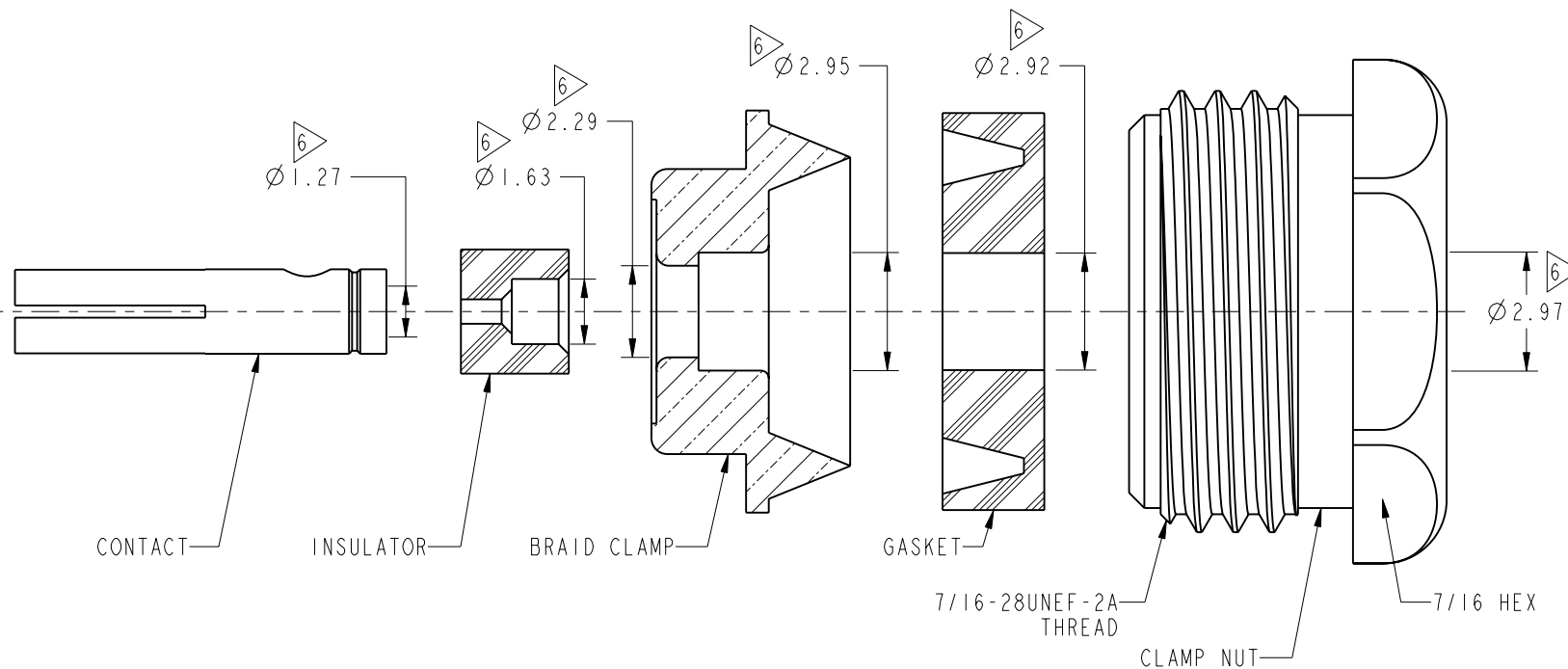
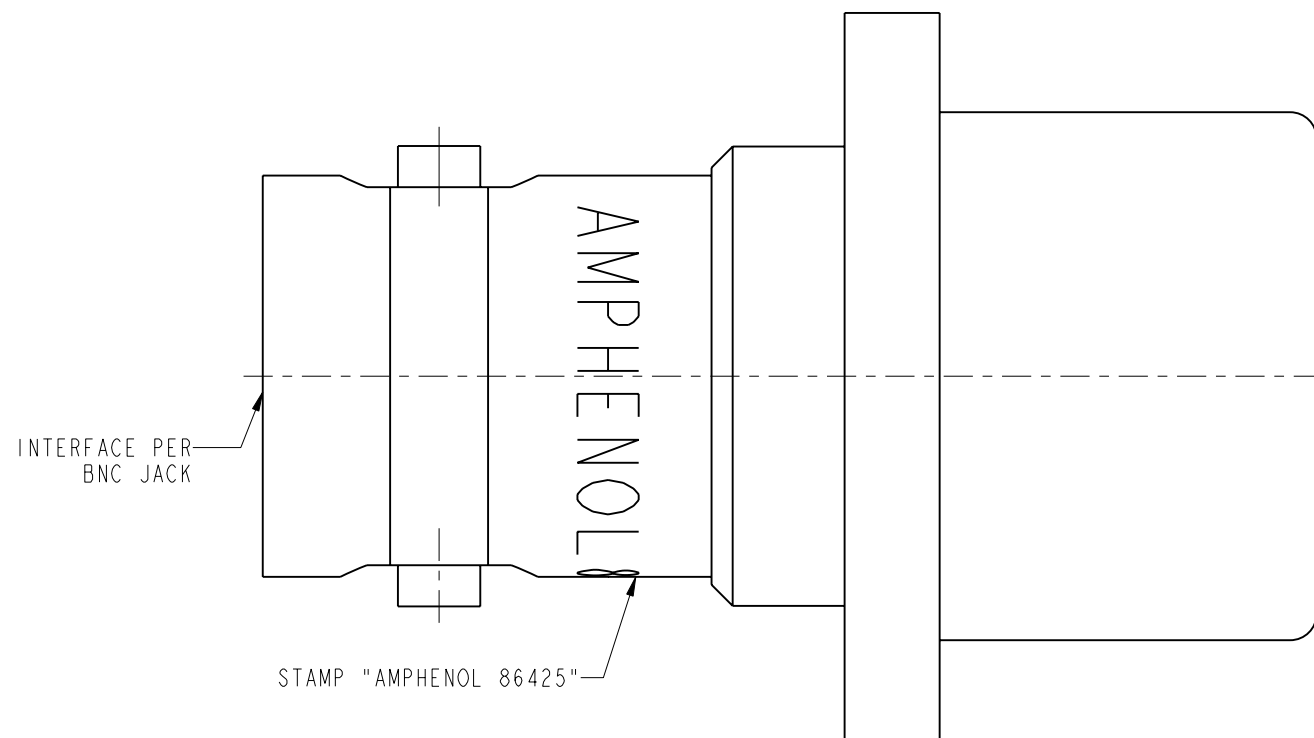

CUSTOMER OUTLINE DRAWING

ALL OTHER SHEETS ARE FOR INTERNAL USE ONLY

UNLESS OTHERWISE SPECIFIED, DIMENSIONS ARE IN METRIC AND TOLERANCES ARE: <0.5mm ±0.05mm 0.5 - 6mm ±0.1mm 6 - 30mm ±0.2mm 30 - 120mm ±0.3mm ANGLES ±1°	MATERIAL	DRAWN	DATE	TITLE BNC STR JACK PANEL FOR RG 188 A/U CABLE		Amphenol RF www.amphenolrf.com
	SEE NOTES	S. DUAN	18-May-15			
NOTICE - These drawings, specifications, or other data (1) are, and remain the property of Amphenol corp. (2) must be returned upon request; and (3) are confidential and not to be disclosed to any person other than those to whom they are given by Amphenol Corp. the furnishing of these drawings, specifications, or other data by Amphenol Corp., or to any other person for any purpose is not to be regarded by implication or otherwise in any manner licensing, granting rights to permitting such holder or any other person to manufacture, use or sell any product, process or design, patented or otherwise, that may in any way be related to or disclosed by said drawings, specifications, or other data.	REFERENCE EAR #	ENGINEER	DATE	SCALE: 5.5:1.0 SHEET 2 OF 2		DRAWING NO.86425
	CONFIGURATION LEVEL: In Work	S. HSIEH	13-Apr-06	DWG SIZE B REV P		ITEM NO.86425
	FINISH	APPROVED	DATE			PART NO.86425

X-ON Electronics

Largest Supplier of Electrical and Electronic Components

Click to view similar products for [RF Connectors / Coaxial Connectors](#) category:

Click to view products by [Amphenol](#) manufacturer:

Other Similar products are found below :

[8915-1511-000](#) [89674-0827](#) [6001-7071-019](#) [6002-7051-003](#) [6002-7551-202](#) [6059674-1](#) [619550-1](#) [630059-000](#) [M39030/3-01N](#) [M3933/25-36N](#) [6500-7071-046](#) [6769](#) [CX050L2AQ](#) [7002-1542-011](#) [7004-1512-000](#) [7009-1511-004](#) [7010-1511-000](#) [7029-1511-060](#) [7101-1541-010](#) [7101-1571-002](#) [7105-1521-002](#) [7145-1521-002](#) [7203-1571-003](#) [7209-1511-011](#) [7210-1511-015](#) [7210-1511-019](#) [73137-5015](#) [73216-2241](#) [7325-1512-000](#) [73404-2300](#) [7405-1521-005](#) [7405-1521-802](#) [7406-1521-005](#) [8527](#) [8547](#) [FS11V](#) [8808-1511-001](#) [9049-9513-000](#) [9074-9513-000](#) [9101-9573-002](#) [910A205F](#) [9130-9573-002](#) [PL11SC-026](#) [PL375-33](#) [PL40-5](#) [PL71-9](#) [PL74C-221](#) [PL75MC-217](#) [PL803-7](#) [980-8666-005](#)