

PRODUCT NUMBER	PACKAGING
10099104-011LF	TRAY

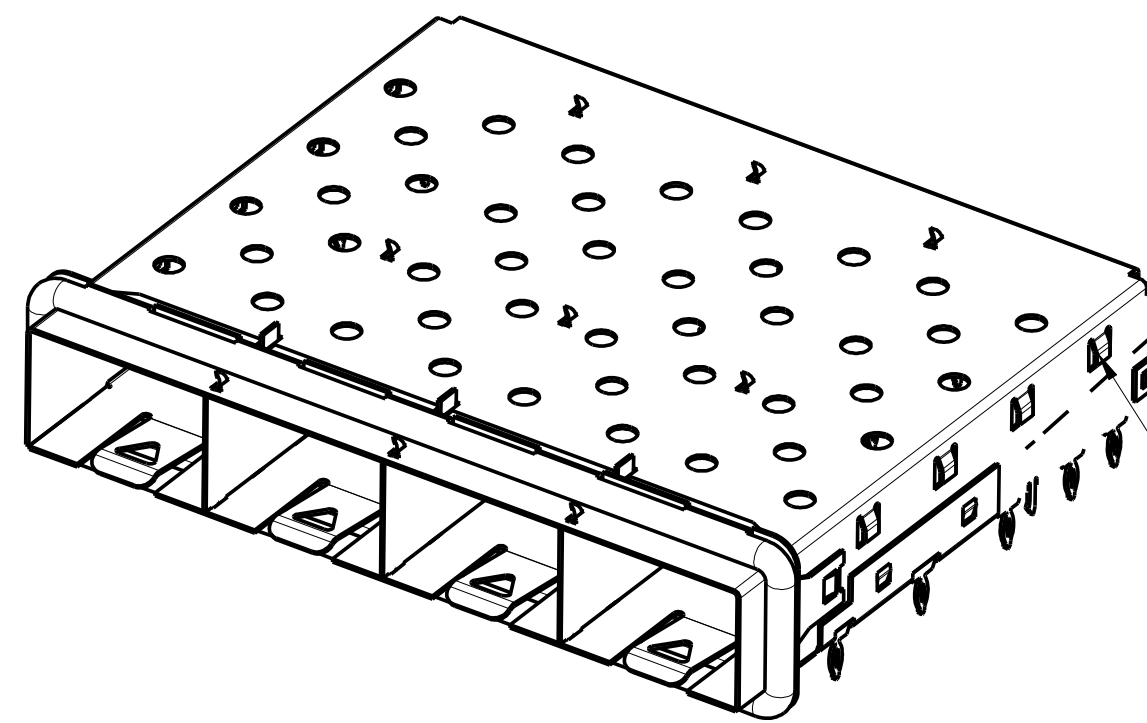

SFP PLUS 1X4 CAGE ASSEMBLY

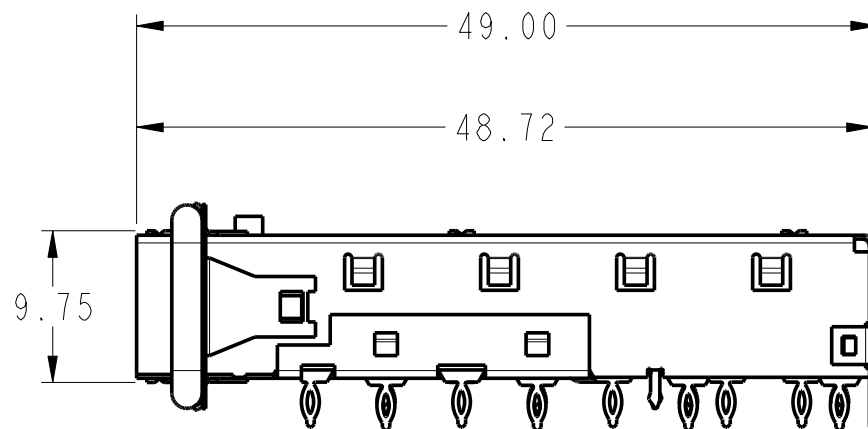
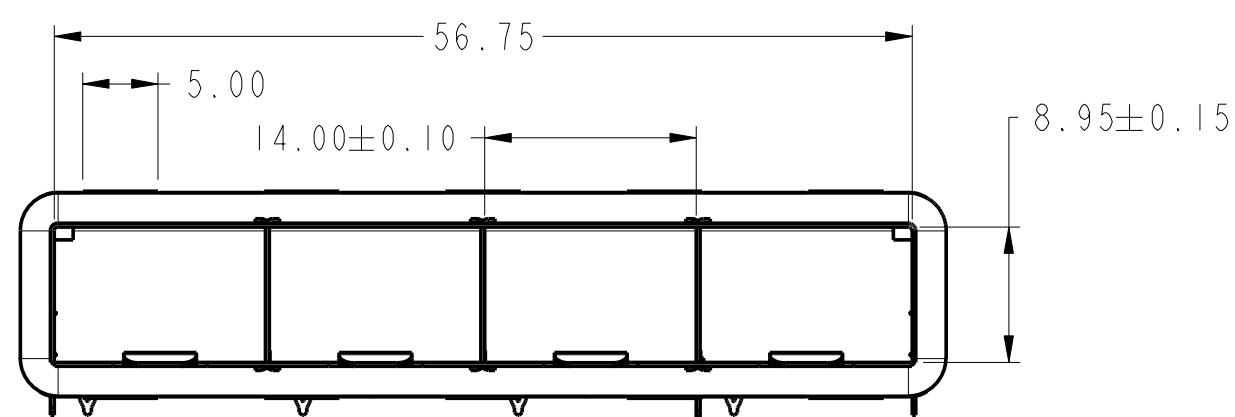
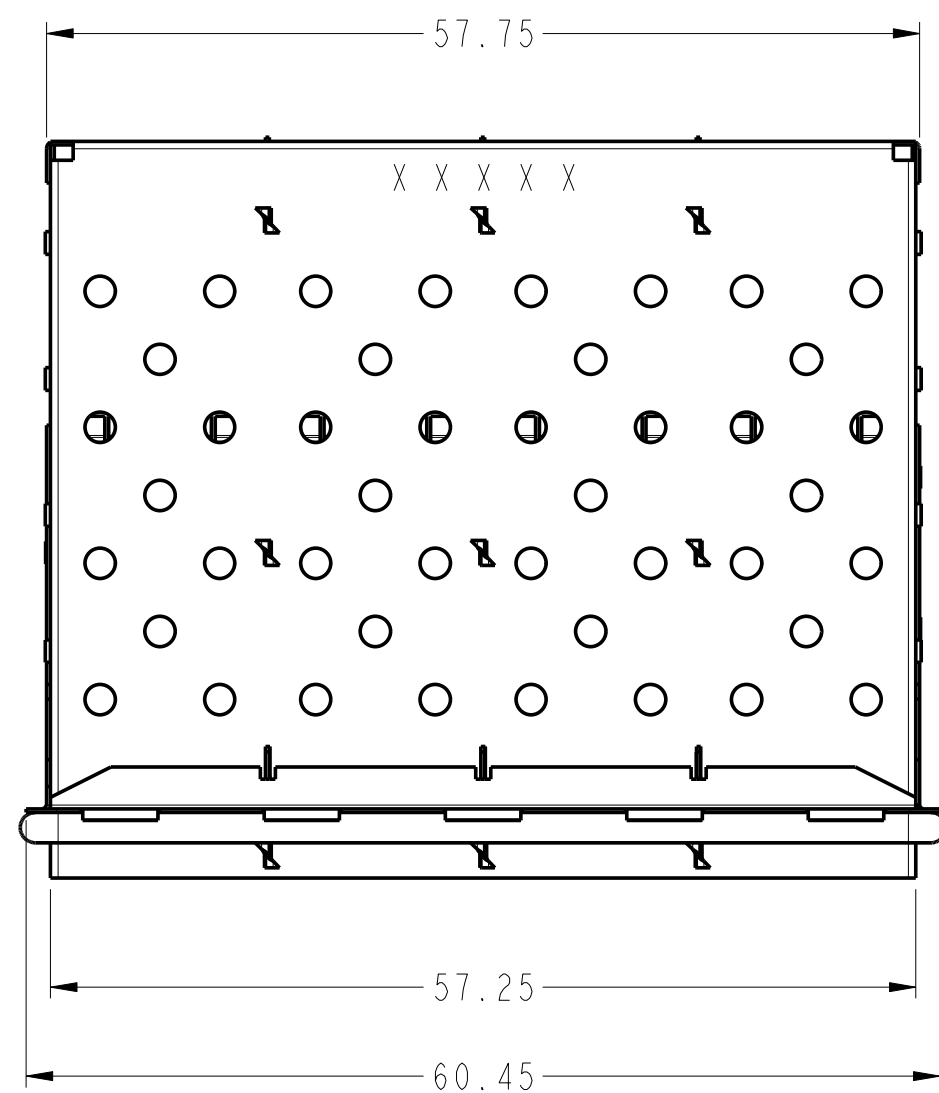
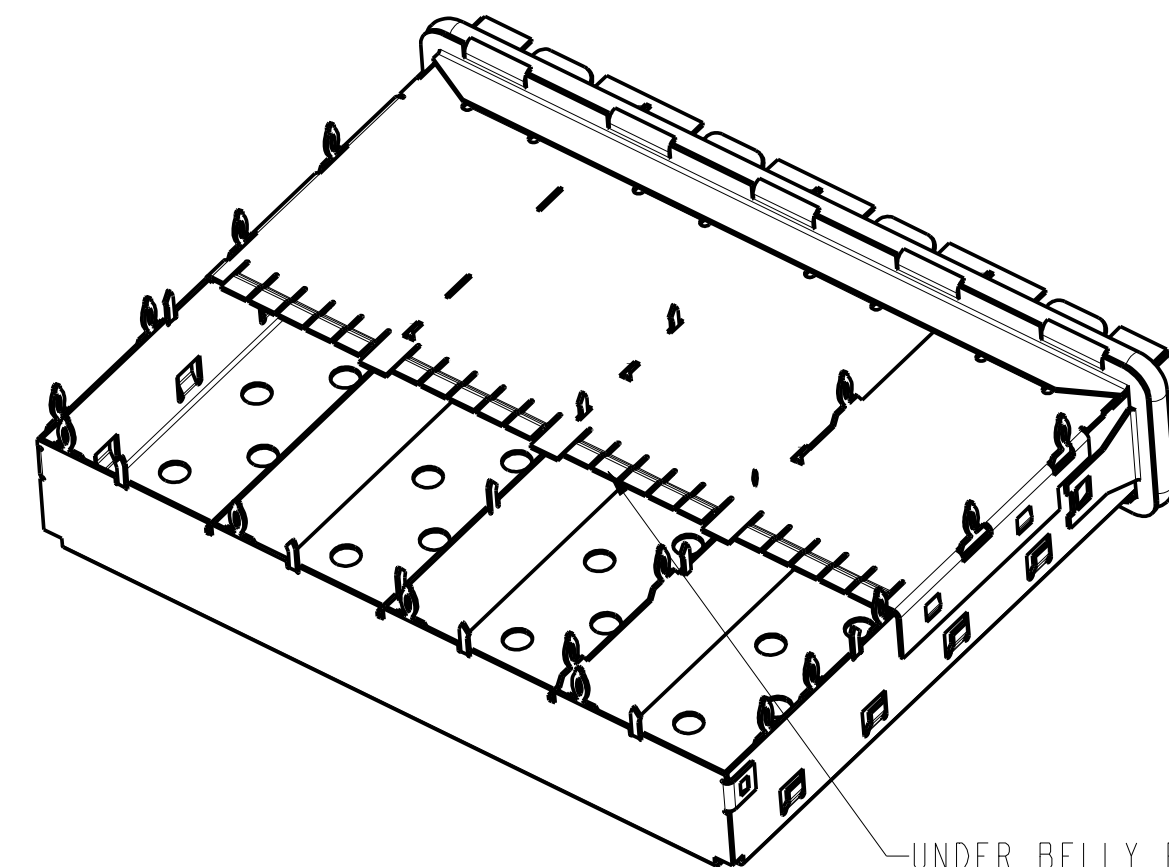

NOTES:

- MATERIAL: CAGE BODY: COPPER ALLOY.
EMI GASKET: CONDUCTIVE ELASTOMER.
GASKET BRACKET: STAINLESS STEEL.
- PLATING: CAGE BODY: 50 u"MIN NICKEL PLATING OVER ALL.
GASKET BRACKET: NONE.
- OPTIONAL LIGHT PIPE COVER ASSEMBLY AVAILABLE.
- PADS AND VIAS ARE CHASSIS GROUND.
- SPACING BETWEEN PORTS TO BE 14.25.
- HATCHED AREA DENOTES COMPONENT AND TRACE KEEP-OUT (EXCEPT CHASSIS GROUND).
- THIS AREA DENOTES COMPONENT KEEP-OUT (TRACES ALLOWED).
- PRODUCT SPECIFICATION: GS-12-616.
- APPLICATION SPECIFICATION: GS-20-125
- PRODUCT MEETS EUROPEAN UNION DIRECTIVES AND OTHER COUNTRY REGULATIONS AS DESCRIBED IN GS-22-008.
- DATE CODE BE PRINTED ON PROPER SURFACE.
- THE CAGE CAN BE ASSEMBLED WITH LIGHT PIPE KIT.
- LIGHT PIPE REFER TO DRAWING NUMBER 10099108 FOR DIMENSIONAL INFORMATION.

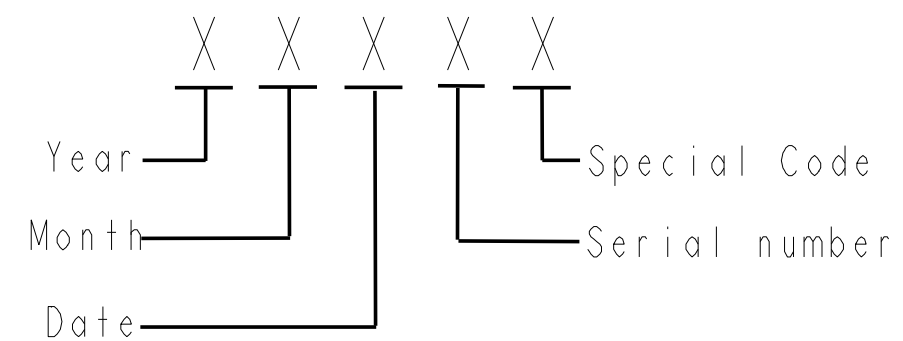

www.fciconnect.com		surface - ✓ ASME Y14.5	tolerance std ASME Y14.5	projection ⊕	MM Scale 2:1
		TOLERANCES UNLESS OTHERWISE SPECIFIED			
Dr	P. S. KUMAR	2009-05-09	ANGULAR	0.X	±0.25
Eng	M. GRAY	2009-05-29	LINEAR	0.XX	±0.15
Chr	M. GRAY	2009-05-29	0° ±1°	0.XXX	±
Appr	M. GRAY	2009-05-29	Product family	SFP+	ECN N10-0376
				Spec ref	RELEASE
FCI		SFP+ 1X4 CAGE WITH LIGHT PIPE HOOKS ELASTOMER TYPE		dwg no	10099104
		catalog no		CUSTOMER	Rev. C

1 2 3 4 5 6 7 8

A
B
C
D
E
F

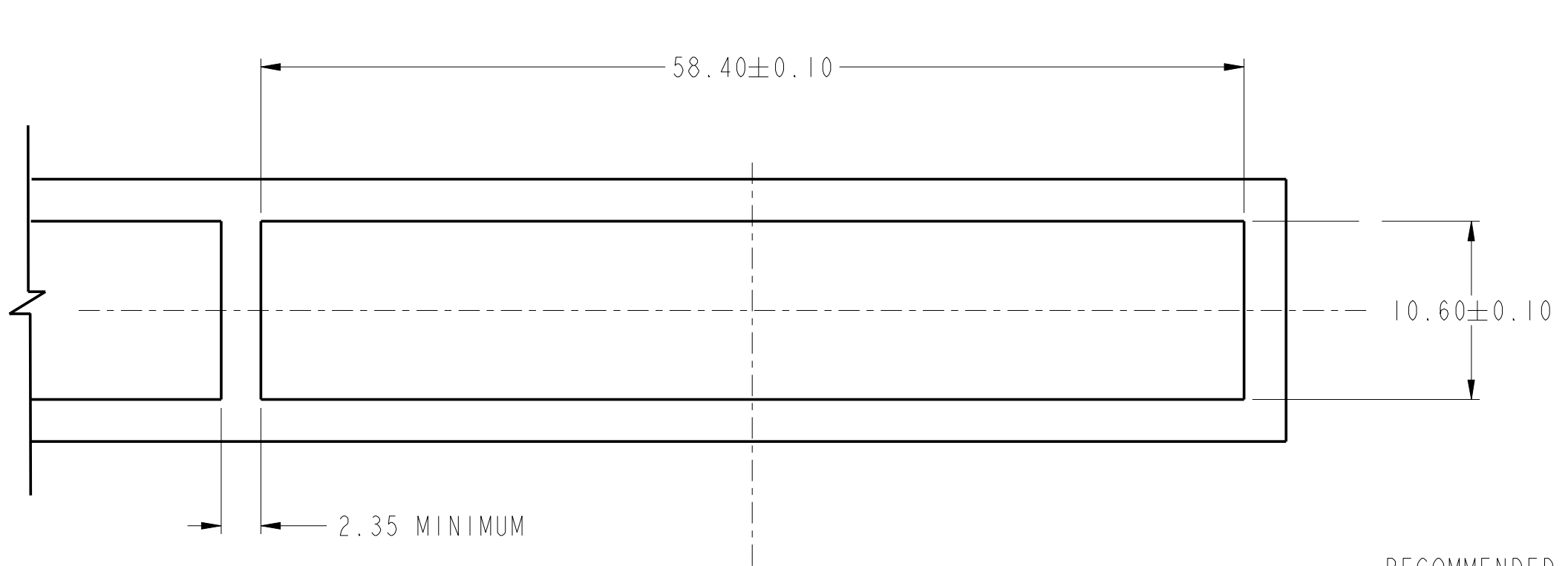

0.19
RECOMMENDED SPACE FROM
TOP OF PCB TO BOTTOM
OF BEZEL OPENNING.

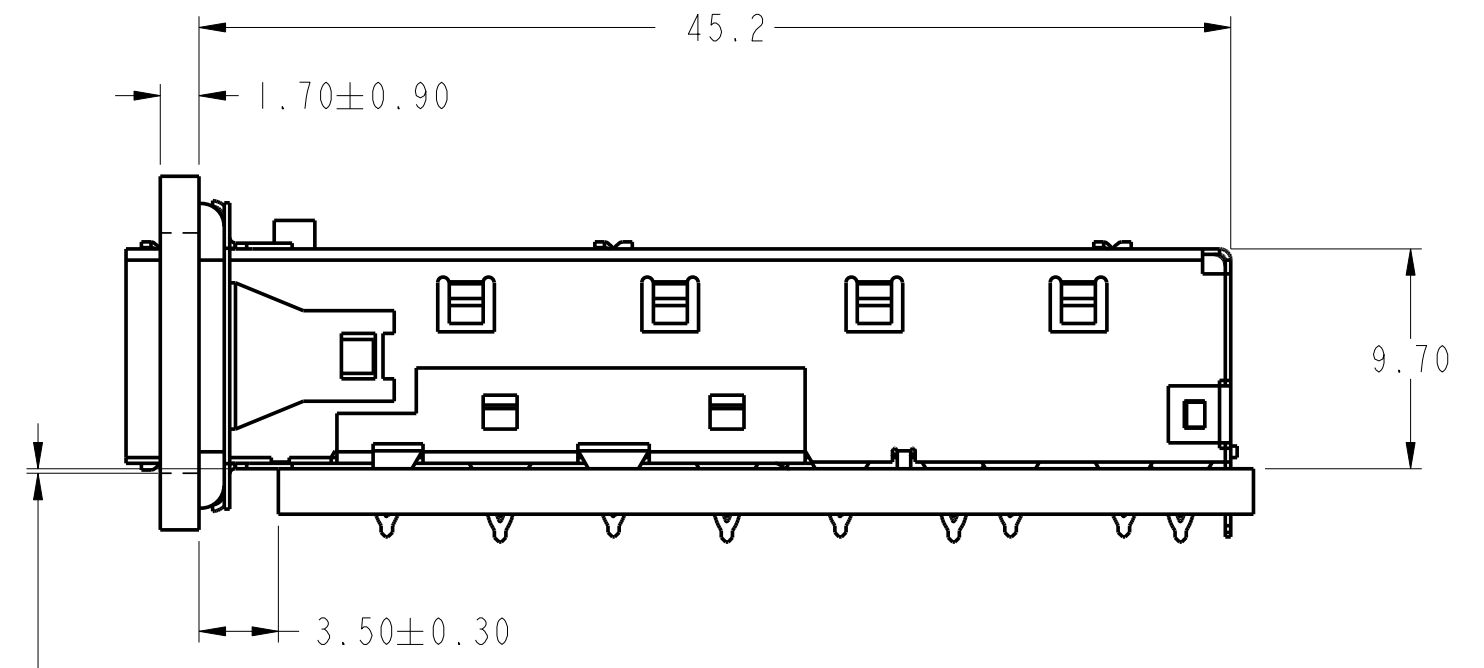

BEZEL AND BOARD DIMENSIONS FOR SINGLE SIDE MOUNTING

Copyright FCI.

www.fciconnect.com		surface ASME Y14.5	-	tolerance std ASME Y14.5	-	projection	MM
		TOLERANCES UNLESS OTHERWISE SPECIFIED					
Dr	P. S. KUMAR	2009-05-09	ANGULAR	0.X	±0.25	size	Scale
Eng	M. GRAY	2009-05-29	LINEAR	0.XX	±0.15	A2	2:1
Chr	M. GRAY	2009-05-29	0° ±1°	0.XXX	±-	ECN	N10-0376
Appr	M. GRAY	2009-05-29	Product family	SFP+		Spec ref	RELEASE
	SFP+ 1X4 CAGE WITH LIGHT PIPE HOOKS		ELASTOMER TYPE		dwg no	10099104	Rev.
		catalog no	CUSTOMER		sheet 3 of 3		

X-ON Electronics

Largest Supplier of Electrical and Electronic Components

Click to view similar products for [I/O Connectors](#) category:

Click to view products by [Amphenol](#) manufacturer:

Other Similar products are found below :

[571763P](#) [58098-0628](#) [61-168618-12P](#) [D38999/20FJ24PA L/C](#) [D38999/20FJ29SB L/C](#) [72.250.1628.2](#) [72.250.2428.2](#) [74720-0505](#) [747680210](#)
[76.350.0729.0](#) [76871-1403](#) [FCN-244F080-G/1](#) [FCN-260A9920](#) [FCN-268D024-G/2F#10X-R10](#) [MP-5T180MUNNA-005](#) [MP-5XRJ45UNNB-](#)
[003](#) [PCS-E50FA](#) [PCS-XE26LKA](#) [PCS-XE26MA+](#) [PCS-XES68MS+](#) [G38A71314B](#) [91-569719-35R](#) [9776-18-6](#) [DX40-50P\(55\)](#) [1571250010](#)
[157-22500-3](#) [MS3471L14-19P L/C](#) [171224-6031](#) [1888020-8](#) [91-569786-35H](#) [91-569786-35M](#) [91-644626-35P](#) [172501-4002](#) [172501-6002](#)
[FCN-260C008-A/L0](#) [FCN-260C024-AL0](#) [FCN-268D008-G/1K](#) [2000314-1](#) [200331-1](#) [2007498-2](#) [PCR-E28LMDAG1+](#) [PCR-E36FC+](#) [PCS-](#)
[E28FS+](#) [PCS-XE26SLFD+](#) [PCS-XE26SLFDT+](#) [G38A71214B](#) [HDRA-E68W1LFDTC-SL+](#) [HDR-E14MSG1+](#) [R88A-CNK81S](#) [CRT1-](#)
[ATT02](#)