

| PRODUCT NUMBER | DESCRIPTION | NOTES |
|------------------|------------------|------------|
| 10117950-XXXXLF | NON-HF | SEE SHT. 3 |
| 10117950-XXXXHLF | HALOGEN FREE (H) | SEE SHT. 3 |

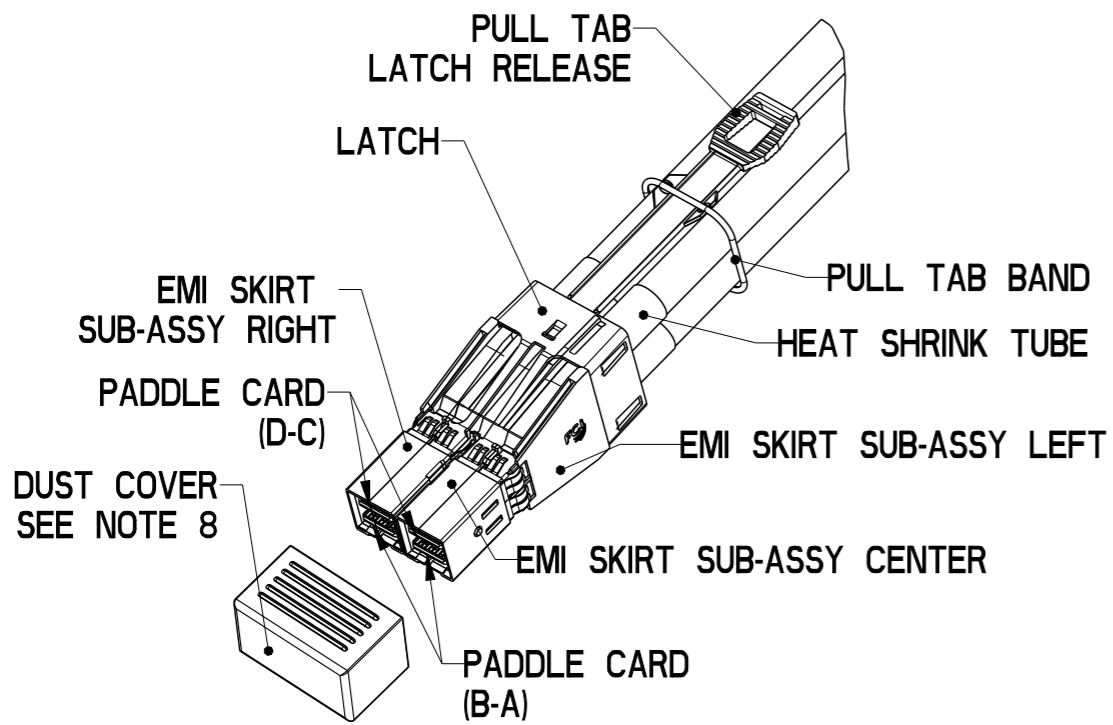
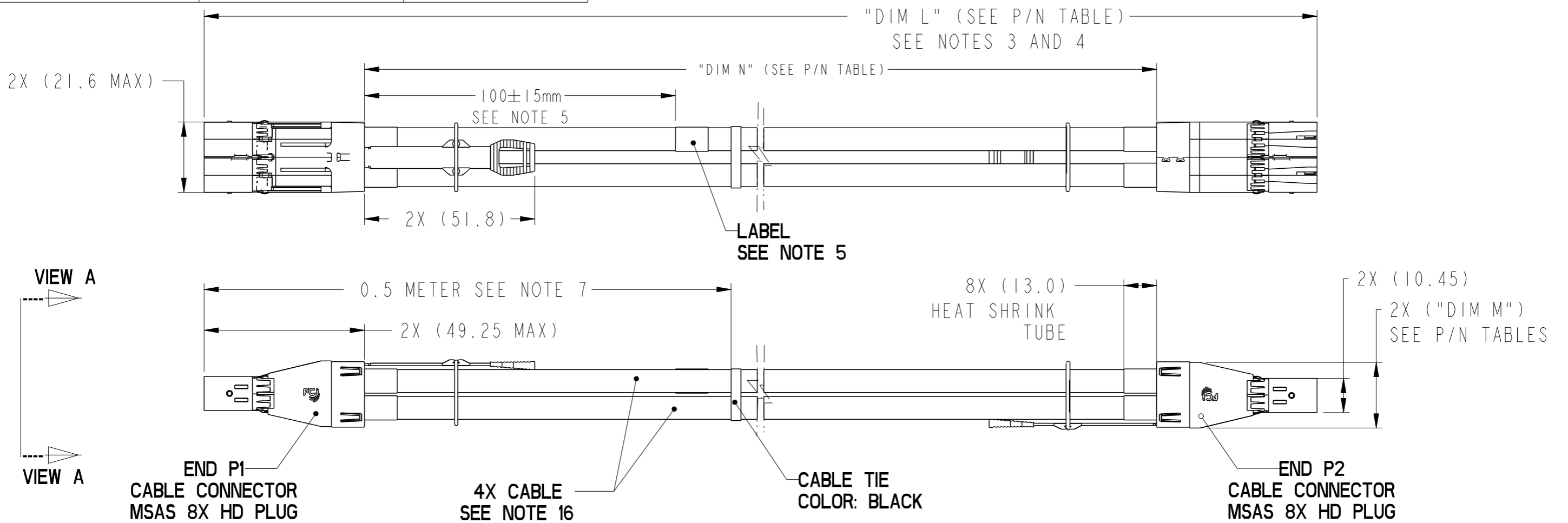

| | | | | | | | | |
|--|----------------|---|----------------|-----|------------------------|-----------------|--------------|-----|
| dr | Deborah Ingram | 2011/11/16 | projection | mm | size | A3 | scale | 4:5 |
| eng | Tom Feng | 2016/06/15 | | | ecn no | ELX-N-24288-1 | | |
| chr | - | - | | | rel level | Released | | |
| appr | Michael Zhou | 2016/09/22 | product family | C&A | | | | |
| Amphenol FCI | | FINAL ASSEMBLY (PASSIVE) MSAS HD 8X ASSEMBLY (12 Gbps) | | | dwg no 10117950 | rev E | | |
| www.fci.com | | cat. no. | - | | Product - Customer Drw | | sheet 1 of 4 | |

| | |
|------------------|------------------|
| PRODUCT NUMBER | DESCRIPTION |
| 10117950-XXXXLF | NON-HF |
| 10117950-XXXXHLF | HALOGEN FREE (H) |

P1-(A) TO P2-(A)
P1-(B) TO P2-(B)

WIRING LIST (SEE NOTE 6)

| END P1 / (A) (B) | | END P2 / (A) (B) | |
|------------------|----------|------------------|----------|
| POSITION | SYMBOL | POSITION | SYMBOL |
| D9 | GROUND | B9 | GROUND |
| D8 | Tx2- | B8 | Rx2- |
| D7 | Tx2+ | B7 | Rx2+ |
| D6 | GROUND | B6 | GROUND |
| D5 | Tx0- | B5 | Rx0- |
| D4 | Tx0+ | B4 | Rx0+ |
| D3 | GROUND | B3 | GROUND |
| D2 | Vman | B2 | ModPrsL |
| D1 | Vact | B1 | Vact |
| C1 | SCL | A1 | Reserved |
| C2 | SDA | A2 | IntL |
| C3 | GROUND | A3 | GROUND |
| C4 | Tx1+ | A4 | Rx1+ |
| C5 | Tx1- | A5 | Rx1- |
| C6 | GROUND | A6 | GROUND |
| C7 | Tx3+ | A7 | Rx3+ |
| C8 | Tx3- | A8 | Rx3- |
| C9 | GROUND | A9 | GROUND |
| B9 | GROUND | D9 | GROUND |
| B8 | Rx2- | D8 | Tx2- |
| B7 | Rx2+ | D7 | Tx2+ |
| B6 | GROUND | D6 | GROUND |
| B5 | Rx0- | D5 | Tx0- |
| B4 | Rx0+ | D4 | Tx0+ |
| B3 | GROUND | D3 | GROUND |
| B2 | ModPrsL | D2 | Vman |
| B1 | Vact | D1 | Vact |
| A1 | Reserved | C1 | SCL |
| A2 | IntL | C2 | SDA |
| A3 | GROUND | C3 | GROUND |
| A4 | Rx1+ | C4 | Tx1+ |
| A5 | Rx1- | C5 | Tx1- |
| A6 | GROUND | C6 | GROUND |
| A7 | Rx3+ | C7 | Tx3+ |
| A8 | Rx3- | C8 | Tx3- |
| A9 | GROUND | C9 | GROUND |

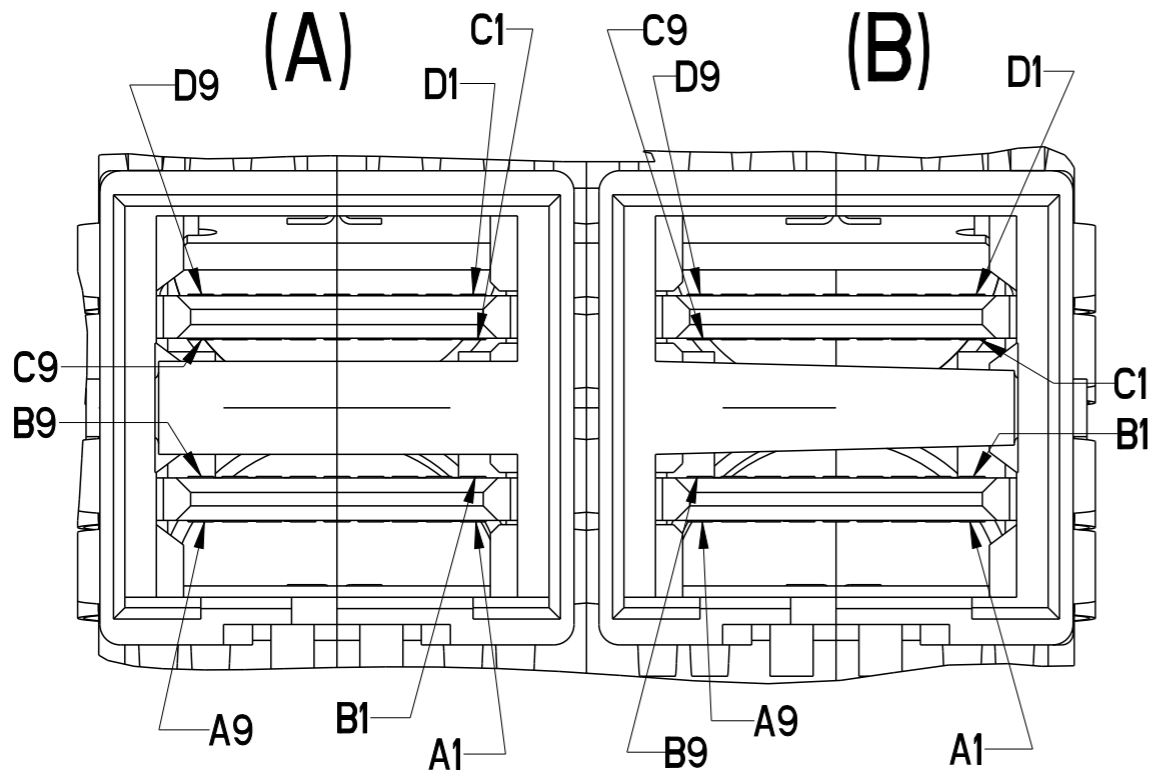

VIEW A (END P1)
SCALE 6:1

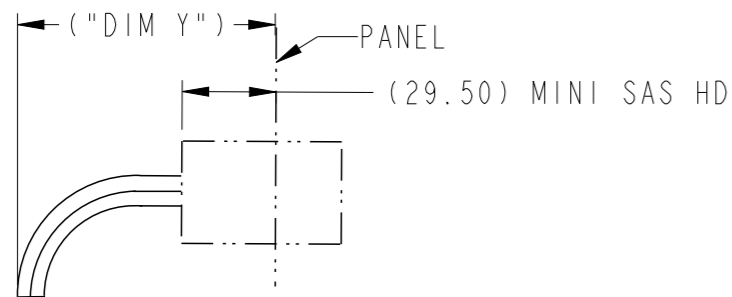

BEND RADIUS
TOP VIEW OF CONNECTOR

| MINI SAS HD MINIMUM CABLE BEND TABLE | | |
|---|-----------------|-----------------------|
| CABLE | ("DIM Y") HF | ("DIM Y") (NON-HF) |
| 24 AWG | 101.2 | 101.2 |
| 26 AWG | 95 | 92.2 |
| 28 AWG | 88 | 85.2 |
| 30 AWG | 83.8 | 79.6 |

LENGEND:

| | |
|--|--------------------------------------|
| | HIGH-SPEED SERIAL DIFFERENTIAL PAIRS |
| | SIGNAL RETURN |
| | POWER AND MANAGEMENT INTERFACE |

SHIELD-----SHIELD

| | | | | | | | | | | |
|--------------------------------|----------------|------------|-------------------------------|-----|--------|-----------------|-----------|----------|------------------------|---|
| dr | Deborah Ingram | 2011/11/16 | projection | mm | size | A3 | scale | 1:1 | | |
| eng | Tom Feng | 2016/06/15 | | ← → | ecn no | ELX-N-24288-1 | rel level | Released | | |
| chr | - | - | | | | | | | | |
| appr | Michael Zhou | 2016/09/22 | product family | C&A | | | | | | |
| Amphenol FCI | | | FINAL ASSEMBLY (PASSIVE) | | | dwg no | | 10117950 | rev | E |
| www.fci.com | | | MSAS HD 8X ASSEMBLY (12 Gbps) | | | cat. no. | | - | Product - Customer Drw | |
| Creo File - REV E - 2016-02-12 | | | PDS: Rev :E | | | STATUS:Released | | | Printed: Sep 22, 2016 | |

| △ PART NUMBER (NON-HALOGEN FREE) SEE NOTE 12 AND 16 | LENGTH "DIM L" (Meters) | LENGTH "DIM N" (Meters) | ("DIM M") (mm) | AWG |
|---|----------------------------|----------------------------|-------------------|-----|
| 10117950-2004LF | (0.43) | 0.33 | 17.3 | 30 |
| 10117950-2005LF | 0.5 | | 17.3 | 30 |
| 10117950-2010LF | 1.0 | | 17.3 | 30 |
| 10117950-2015LF | 1.5 | | 17.3 | 30 |
| 10117950-2020LF | 2.0 | | 17.3 | 30 |
| 10117950-3010LF | 1.0 | | 17.3 | 28 |
| 10117950-3015LF | 1.5 | | 17.3 | 28 |
| 10117950-3020LF | 2.0 | | 17.3 | 28 |
| 10117950-3025LF | 2.5 | | 17.3 | 28 |
| 10117950-3030LF | 3.0 | | 17.3 | 28 |
| 10117950-4010LF | 1.0 | | 20.1 | 26 |
| 10117950-4015LF | 1.5 | | 20.1 | 26 |
| 10117950-4020LF | 2.0 | | 20.1 | 26 |
| 10117950-4025LF | 2.5 | | 20.1 | 26 |
| 10117950-4030LF | 3.0 | | 20.1 | 26 |
| 10117950-4035LF | 3.5 | | 20.1 | 26 |
| 10117950-4040LF | 4.0 | | 20.1 | 26 |
| 10117950-4045LF | 4.5 | | 20.1 | 26 |
| 10117950-4050LF | 5.0 | | 20.1 | 26 |
| 10117950-4055LF | 5.5 | | 20.1 | 26 |
| 10117950-4060LF | 6.0 | | 20.1 | 26 |
| 10117950-5010LF | 1.0 | | 20.1 | 24 |
| 10117950-5015LF | 1.5 | | 20.1 | 24 |
| 10117950-5020LF | 2.0 | | 20.1 | 24 |
| 10117950-5025LF | 2.5 | | 20.1 | 24 |
| 10117950-5030LF | 3.0 | | 20.1 | 24 |
| 10117950-5035LF | 3.5 | | 20.1 | 24 |
| 10117950-5040LF | 4.0 | | 20.1 | 24 |
| 10117950-5045LF | 4.5 | | 20.1 | 24 |
| 10117950-5050LF | 5.0 | | 20.1 | 24 |
| 10117950-5055LF | 5.5 | | 20.1 | 24 |
| 10117950-5060LF | 6.0 | | 20.1 | 24 |
| 10117950-5065LF | 6.5 | | 20.1 | 24 |
| 10117950-5070LF | 7.0 | | 20.1 | 24 |
| 10117950-5075LF | 7.5 | | 20.1 | 24 |
| 10117950-5080LF | 8.0 | | 20.1 | 24 |

| △ PART NUMBER (HALOGEN FREE) SEE NOTE 11 AND 16 | LENGTH "DIM L" (Meters) | LENGTH "DIM N" (Meters) | ("DIM M") (mm) | AWG |
|--|----------------------------|----------------------------|-------------------|-----|
| 10117950-2004HLF | (0.43) | 0.33 | 17.3 | 30 |
| 10117950-2005HLF | 0.5 | | 17.3 | 30 |
| 10117950-2010HLF | 1.0 | | 17.3 | 30 |
| 10117950-2015HLF | 1.5 | | 17.3 | 30 |
| 10117950-2020HLF | 2.0 | | 17.3 | 30 |
| 10117950-3010HLF | 1.0 | | 17.3 | 28 |
| 10117950-3015HLF | 1.5 | | 17.3 | 28 |
| 10117950-3020HLF | 2.0 | | 17.3 | 28 |
| 10117950-3025HLF | 2.5 | | 17.3 | 28 |
| 10117950-3030HLF | 3.0 | | 17.3 | 28 |
| 10117950-4010HLF | 1.0 | | 20.1 | 26 |
| 10117950-4015HLF | 1.5 | | 20.1 | 26 |
| 10117950-4020HLF | 2.0 | | 20.1 | 26 |
| 10117950-4025HLF | 2.5 | | 20.1 | 26 |
| 10117950-4030HLF | 3.0 | | 20.1 | 26 |
| 10117950-4035HLF | 3.5 | | 20.1 | 26 |
| 10117950-4040HLF | 4.0 | | 20.1 | 26 |
| 10117950-4045HLF | 4.5 | | 20.1 | 26 |
| 10117950-4050HLF | 5.0 | | 20.1 | 26 |
| 10117950-4055HLF | 5.5 | | 20.1 | 26 |
| 10117950-4060HLF | 6.0 | | 20.1 | 26 |
| 10117950-5010HLF | 1.0 | | 20.1 | 24 |
| 10117950-5015HLF | 1.5 | | 20.1 | 24 |
| 10117950-5020HLF | 2.0 | | 20.1 | 24 |
| 10117950-5025HLF | 2.5 | | 20.1 | 24 |
| 10117950-5030HLF | 3.0 | | 20.1 | 24 |
| 10117950-5035HLF | 3.5 | | 20.1 | 24 |
| 10117950-5040HLF | 4.0 | | 20.1 | 24 |
| 10117950-5045HLF | 4.5 | | 20.1 | 24 |
| 10117950-5050HLF | 5.0 | | 20.1 | 24 |
| 10117950-5055HLF | 5.5 | | 20.1 | 24 |
| 10117950-5060HLF | 6.0 | | 20.1 | 24 |
| 10117950-5065HLF | 6.5 | | 20.1 | 24 |
| 10117950-5070HLF | 7.0 | | 20.1 | 24 |
| 10117950-5075HLF | 7.5 | | 20.1 | 24 |
| 10117950-5080HLF | 8.0 | | 20.1 | 24 |
| 10117950-5090HLF ONLY USE EXT MSHD INTERFACE DON'T MEET SAS3.0 APPLICATION | 9.0 | | 20.1 | 24 |
| 10117950-5100HLF ONLY USE EXT MSHD INTERFACE DON'T MEET SAS3.0 APPLICATION | 10.0 | | 20.1 | 24 |

Amphenol FCI

© 2016 AFCI

| | | | | | |
|--------------|----------------|------------|--------------------------|-------------------------|-----------------------|
| dr | Deborah Ingram | 2011/11/16 | projection | size A3 | scale 1:1 |
| eng | Tom Feng | 2016/06/15 | | | |
| chr | - | - | product family C&A | ecn no ELX-N-24288-1 | rel level Released |
| appr | Michael Zhou | 2016/09/22 | | | |
| Amphenol FCI | | | FINAL ASSEMBLY (PASSIVE) | dwg no 10117950 | rev E |
| www.fci.com | | | cat. no. | Product - Customer Drw | |
| | | | sheet 3 of 4 | | |

| | |
|------------------|------------------|
| PRODUCT NUMBER | DESCRIPTION |
| 10117950-XXXXLF | NON-HF |
| 10117950-XXXXHLF | HALOGEN FREE (H) |

NOTES:

- MATERIAL:
 BACK SHELLS: ZINC ALLOY/ COPPER UNDERPLATE/ NICKEL OVERPLATE
 PULL TAB: THERMOPLASTIC POLYMER
 LATCH : STAINLESS STEEL
 FERRULE: BRASS
 EMI SKIRT: STAINLESS STEEL
 LOCTITE
 PADDLE CARD: PRINTED CIRCUIT SUBSTRATE
 HEAT SHRINK TUBE: POLYOLEFIN
- THIS PRODUCT MEETS THE RESTRICTION OF HAZARDOUS SUBSTANCES IN ELECTRICAL AND ELECTRONIC EQUIPMENT (RoHS) DIRECTIVE (2011/65/EU)
- THIS DIMENSION IS A FINISHED PRODUCT LENGTH.
- UNLESS OTHERWISE SPECIFIED ASSEMBLED LENGTH TOLERANCE IS TO BE:
 "DIM L" < 1 METER = ±25mm
 "DIM L" 1 METER TO 4 METERS = ± 2% OF "DIM L"
 "DIM L" > 4 METERS = +0.00/-4% OF "DIM L"

5. LABEL DETAILS:

| | | |
|---|-------------------------------|----------------|
| △ | MANUFACTURER CODE OR NAME | COUNTRY ORIGIN |
| | FCI P/N | |
| | FCI CUSTOMER DRAWING REVISION | |
| | FCI SERIAL NUMBER | |
| | BAR CODE OF SERIAL NUMBER | |

FONT SHALL BE CLEARLY VISIBLE AND BLACK IN COLOR.

SERIAL NUMBER IS ONLY USED FOR TRACKING PRODUCT,DETAIL IS AS BELOW :

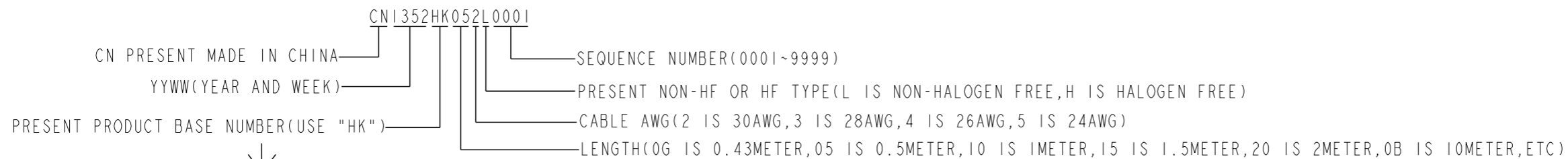

CABLE LABEL EXAMPLE:

| |
|------------------|
| FCI CHINA |
| 10117950-2005LF |
| REV.E |
| CN1352HK052L0001 |
| |

- ALL CABLE ASSEMBLIES 100% TESTED FOR CONTINUITY AS DEFINED IN WIRING LIST.
- PLACE A CABLE TIE EVERY 0.5 METER ON ALL ASSEMBLIES, UNLESS OTHERWISE SPECIFIED. IN CASE OF 0.5 METER CABLE ASSEMBLY, CABLE TIE IS TO BE APPLIED AT THE MIDWAY POINT.
- OTHER TESTING PERFORMED AS REQUIRED BY PRODUCT SPECIFICATION: GS-12-651.
- PACKAGING OF LEAD FREE PRODUCTS MEETS LABELING AND PACKAGING PER SPECIFICATION GS-14-920. PACKAGE CABLE ASSEMBLIES PER GS-14-1272. DUST COVERS ARE TO BE ASSEMBLED PRIOR TO PACKAGING. FCI PACKAGE TRACKING BAG LABEL IS ONLY FOR REFERENCE.

NOTES CONTINUED:

- A "△" SYMBOL WILL BE NEXT TO ANY DIMENSION, VIEW, OR NOTE WHICH HAS BEEN MODIFIED WITH THE CURRENT DRAWING REVISION. THE CURRENT REVISION WILL BE SHOWN IN THE SYMBOL.
- "H" PRODUCT NUMBERS DESIGNATE THE USE OF HALOGEN FREE RAW CABLE.
- HALOGEN FREE RAW CABLE CAN BE USED AS A SUBSTITUTE ON NON-HF PRODUCT NUMBERS.
- CABLE ASSEMBLY CAN MEET SAS 3.0 SPECIFICATION.
- MATES TO SERIES: 10112626 or 10112627 Or 10112628
- EEPROM INFORMATION REFER TO FCI LATEST PRODUCT SPEC. GS-12-651.
- CABLE IS OPTIONAL, WHICH HAD BEEN QUALIFIED BY FCI AND MEET FCI PRODUCT SPEC. GS-12-651.

| | | | | | | | | | |
|--------------|----------------|--------------------------|----------------|----------|------------------------|---------------|--------------|-----|---|
| dr | Deborah Ingram | 2011/11/16 | projection | mm ←→ | size | A3 | scale | 1:2 | |
| eng | Tom Feng | 2016/06/15 | | | ecn no | ELX-N-24288-1 | | | |
| chr | - | - | | | rel level | Released | | | |
| appr | Michael Zhou | 2016/09/22 | product family | C&A | | rel level | Released | | |
| Amphenol FCI | | FINAL ASSEMBLY (PASSIVE) | | | dwg no | 10117950 | | rev | E |
| www.fci.com | | cat. no. | - | | Product - Customer Drw | | sheet 4 of 4 | | |

X-ON Electronics

Largest Supplier of Electrical and Electronic Components

Click to view similar products for [Computer Cables](#) category:

Click to view products by [Amphenol](#) manufacturer:

Other Similar products are found below :

[68809-0004](#) [8F36-AAA105-1.00](#) [IB63](#) [CB-716EB-RS](#) [CB-716P8P9-RS](#) [CBK-11-290K-00](#) [ACL-10550](#) [ACL-10568-2](#) [ACL-10568-5](#)
[427522400-3](#) [32102-021500-200-RS](#) [426091300-3](#) [48000023](#) [10114976-P015002LF](#) [88761-6101](#) [NT631C-CN321-EU](#) [ACL-10568NF-1](#)
[MIKROE-2092](#) [PCL-101100R-2E](#) [1700009405](#) [PS/2 Cable](#) [NT31C-CN323-EU](#) [FWAX-PK1-51](#) [PCL-10168H-1E](#) [68801-1905](#) [111068-1015](#)
[100436-1107](#) [68801-0630](#) [68801-3612](#) [68801-3618](#) [205058-1002](#) [PS2NK](#) [SATA cable](#) [96021-0000-00-0](#) [FAK-SMZSMZ 5M](#) [FAK-](#)
[SMZSMZ-3M](#) [ACC-500-200-R](#) [iW-C40-PCIe08-C1](#) [1700001531](#) [96048-0000-00-0](#) [SATA III cable 30cm, down/straight](#) [cab-Pico-ITX-](#)
[LVDS](#) [PCL-101100SB-2E](#) [AXXSTCBLQAT](#) [NT31C-KBA05](#) [PCL-101100M-2E](#) [A2U4PSWCXCXK1](#) [2 port SATA to 5 pin,L=200mm](#)
[ACL-10568NF-2](#) [C-PS2WG/5](#)