

FCI PART NUMBER	DESCRIPTION	NOTES
10119217-XXXXLF	CONTROLLER TO BACKPLANE CONFIGURATION	SEE TABLE 1

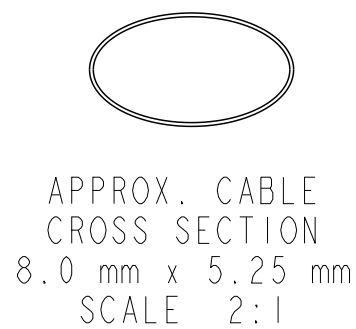
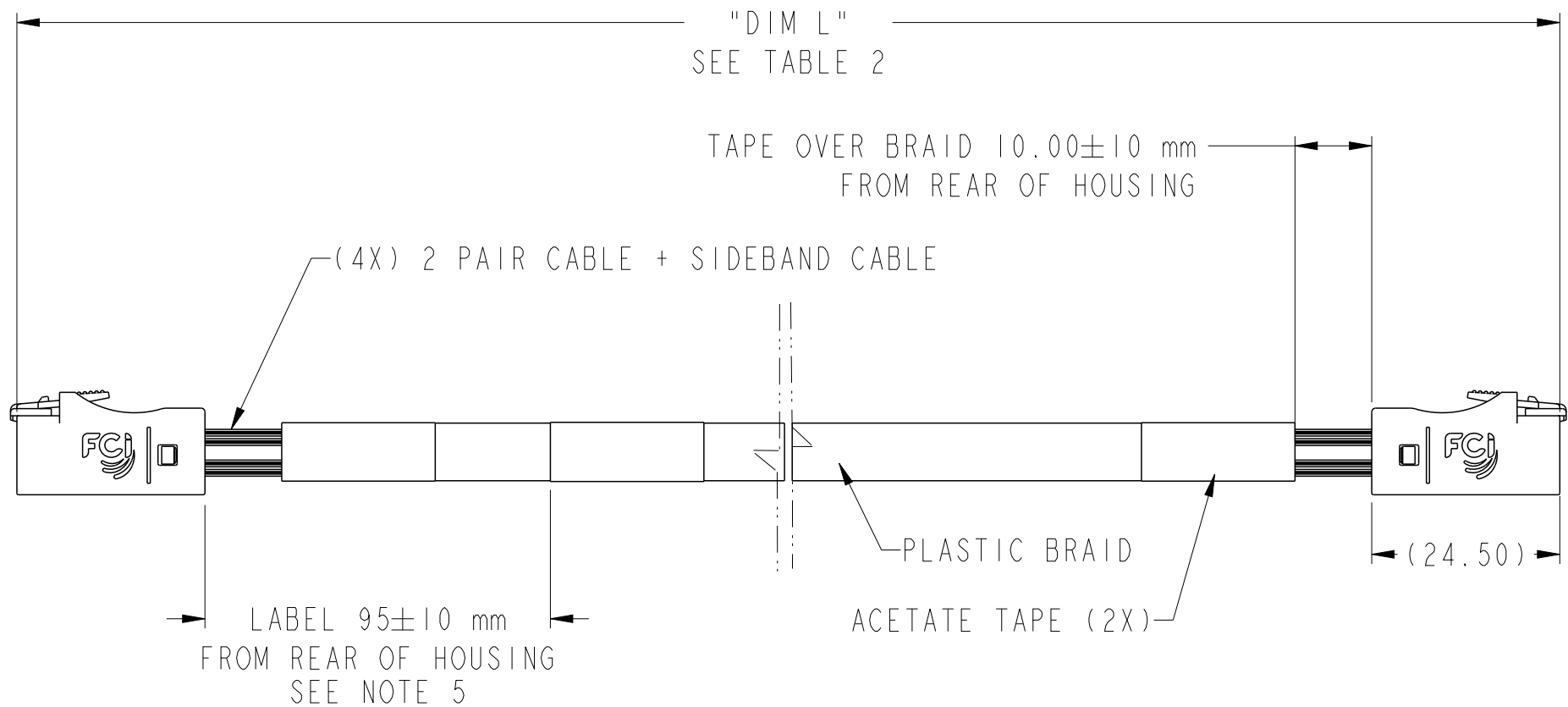
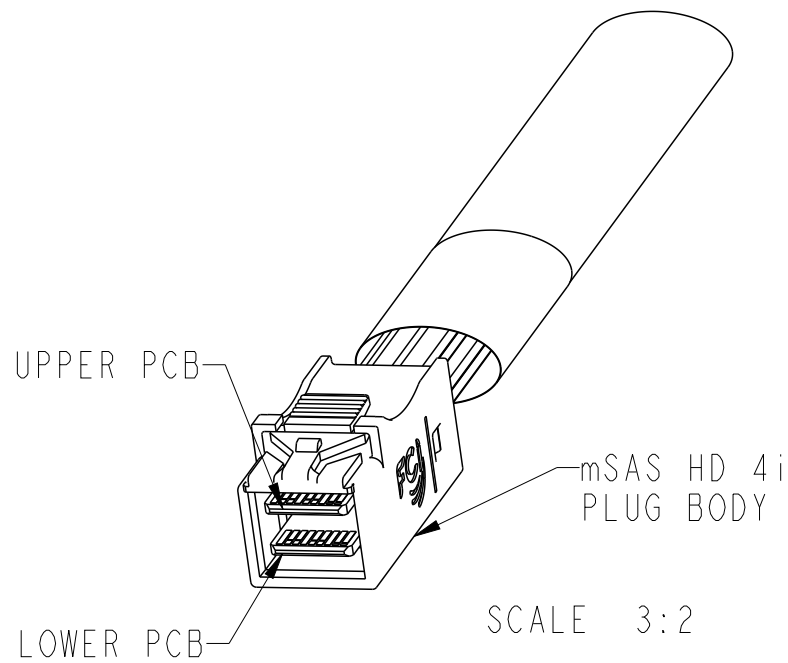

spec ref	-	dr	David Lord	2011/12/15	projection	mm	size	A3	scale	1:1
tolerance std	ISO 406 ISO 1101	eng	Ya LI	2018/01/16			ecn no	ELX-N-29059-1		
TOLERANCES UNLESS OTHERWISE SPECIFIED		chr	-	-			product family	-	rel level	Released
surface	 ISO 1302	linear	0.X	±0.3	Amphenol FCI mSAS HD INTERNAL (4i) CABLE ASSEMBLY- 12 Gb/s www.fci.com	cat. no. -	dwg no 10119217	rev F	Product - Customer Drw	
	angular	0°	±2°	sheet 1 of 4						

FCI PART NUMBER	DESCRIPTION	NOTES
10119217-XXXXLF	CONTROLLER TO BACKPLANE CONFIGURATION	SEE TABLE 1

TABLE 2- CABLE PART NUMBER LIST

PART NUMBER	"DIM L" CABLE LENGTH (METERS)	AWG	NOTES
10119217-2030LF	0.3	30	CONTROLLER TO BACKPLANE WIRING CONFIGURATION (SHEET 2) ----- (SEE SHEET 4 FOR ALL NOTES)
10119217-2040LF	0.4	30	
10119217-2050LF	0.5	30	
10119217-2060LF	0.6	30	
10119217-2070LF	0.7	30	
10119217-2080LF	0.8	30	
10119217-2090LF	0.9	30	
10119217-2100LF	1.0	30	
10119217-2125LF	1.25	30	
10119217-2200LF	2.0	30	
10119217-2095LF	0.95	30	
10119217-2025LF	0.25	30	



NOTE:
 1. ALL CABLE PERFORMANCE COMPLIANCE SAS3.0
 2. CABLE MORE THAN 1.0 METER COULD NOT MEET SAS3.0 INSERTION LOSS -11dB MAX.

Amphenol FCI

© 2016 AFCI

spec ref	-	dr	David Lord	2011/12/15	projection	mm	size	A3	scale	1:1	
tolerance std	ISO 406 ISO 1101	eng	Ya Li	2018/01/16			ecn no	ELX-N-29059-1			
	TOLERANCES UNLESS OTHERWISE SPECIFIED	chr	-	-			rel level	Released			
surface	linear	appr	Caspar Lin	2018/01/24	product family	-	dwg no	10119217		rev	F
	angular	Amphenol FCI		www.fci.com	mSAS HD INTERNAL (4i) CABLE ASSEMBLY- 12 Gb/s		cat. no.	-	Product - Customer Drw	sheet 2 of 4	

FCI PART NUMBER	DESCRIPTION	NOTES
10119217-XXXXLF	CONTROLLER TO BACKPLANE CONFIGURATION	SEE TABLE 1

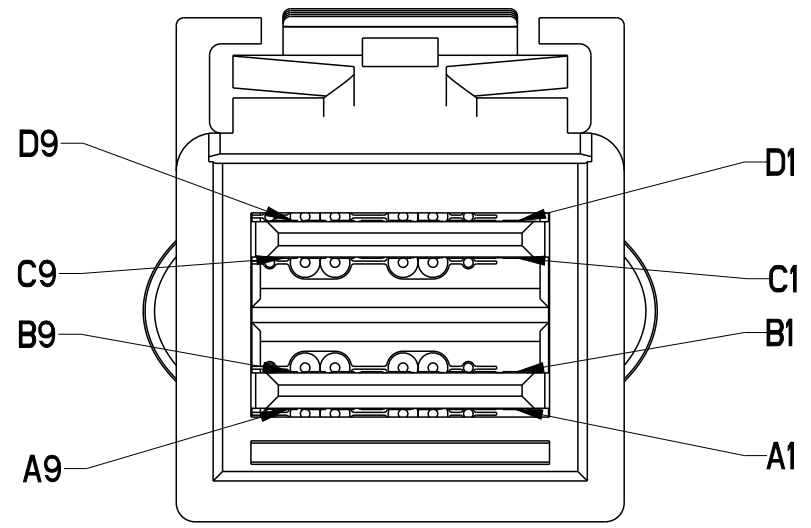

SCALE 5:1

LEGEND	
	HIGH-SPEED SERIAL DIFFERENTIAL PAIRS
	SIGNAL RETURN
	SIDEBAND SIGNAL

WIRING LIST (CONTROLLER TO BACKPLANE)				
END P1 (CONTROLLER)			END P2 (BACKPLANE)	
POSITION	SYMBOL		POSITION	SYMBOL
D9	GROUND	-----	B9	GROUND
D8	Tx2-		B8	Rx2-
D7	Tx2+		B7	Rx2+
D6	GROUND	-----	B6	GROUND
D5	Tx0-		B5	Rx0-
D4	Tx0+		B4	Rx0+
D3	GROUND	-----	B3	GROUND
D2	SIDEBAND 6		D1	SIDEBAND 6
D1	SIDEBAND 5		D2	SIDEBAND 5
C1	SIDEBAND 4		C2	SIDEBAND 4
C2	SIDEBAND 2		C1	SIDEBAND 2
C3	GROUND	-----	A3	GROUND
C4	Tx1+		A4	Rx1+
C5	Tx1-		A5	Rx1-
C6	GROUND	-----	A6	GROUND
C7	Tx3+		A7	Rx3+
C8	Tx3-		A8	Rx3-
C9	GROUND	-----	A9	GROUND
B9	GROUND	-----	D9	GROUND
B8	Rx2-		D8	Tx2-
B7	Rx2+		D7	Tx2+
B6	GROUND	-----	D6	GROUND
B5	Rx0-		D5	Tx0-
B4	Rx0+		D4	Tx0+
B3	GROUND	-----	D3	GROUND
B2	SIDEBAND 1		B1	SIDEBAND 1
B1	SIDEBAND 3		B2	SIDEBAND 3
A1	SIDEBAND 7		A2	SIDEBAND 7
A2	SIDEBAND 0		A1	SIDEBAND 0
A3	GROUND	-----	C3	GROUND
A4	Rx1+		C4	Tx1+
A5	Rx1-		C5	Tx1-
A6	GROUND	-----	C6	GROUND
A7	Rx3+		C7	Tx3+
A8	Rx3-		C8	Tx3-
A9	GROUND	-----	C9	GROUND

spec ref	-	dr	David Lord	2011/12/15	projection	mm	size	A3	scale	2:1
tolerance std	ISO 406 ISO 1101	eng	Ya LI	2018/01/16		← →	ecn no	ELX-N-29059-1		
TOLERANCES UNLESS OTHERWISE SPECIFIED		chr	-	-				rel level	Released	
surface	linear	0.X	±0.3	appr	Caspar Lin	2018/01/24	product family	-	dwg no	10119217
		0.XX	±0.10	Amphenol FCI		mSAS HD INTERNAL (4i)		rev	F	
		0.XXX	±0.005	www.fci.com		CABLE ASSEMBLY- 12 Gb/s		sheet 3 of 4		
	angular	0°	±2°	cat. no.		-		Product - Customer Drw		

Amphenol FCI

© 2016 AFCI

FCI PART NUMBER	DESCRIPTION	NOTES
10119217-XXXXLF	CONTROLLER TO BACKPLANE CONFIGURATION	SEE TABLE 1

NOTES:

- MATERIAL:
HOUSINGS: MODIFIED POLYPHENYLENE ETHER
PADDLE CARD: PRINTED CIRCUIT SUBSTRATE
HEAT SHRINK TUBE: POLYOLEFIN
EPOXY LOCTITE
- THIS PRODUCT MEETS THE RESTRICTION OF HAZARDOUS SUBSTANCES IN ELECTRICAL AND ELECTRONIC EQUIPMENT (RoHS) DIRECTIVE (2002/95/EC)
- THIS DIMENSION IS A FINISHED PRODUCT LENGTH.
- UNLESS OTHERWISE SPECIFIED ASSEMBLED LENGTH TOLERANCE IS TO BE:
"DIM L" < 1 METER = ±25mm
"DIM L" 1 METER TO 10 METERS = ± 2% OF "DIM L"
- UNLESS OTHERWISE SPECIFIED LABEL POSITION IS TO BE 95mm FROM REAR OF PI CONNECTOR.
LABEL DETAILS:
MANUFACTURER CODE OR NAME COUNTRY OF ORIGIN
CUSTOMER P/N OR FCI P/N
REVISION
DATE CODE (YYYY/MM/DD FORMAT) - SERIAL NUMBER

FONT SHALL BE CLEARLY VISIBLE AND BLACK IN COLOR.
- ALL CABLE ASSEMBLIES SHALL BE 100% TESTED FOR CONTINUITY AS DEFINED IN WIRING LIST.
- ALL CABLE ASSEMBLIES SHALL BE 100% HI-POT TESTED BY APPLYING 300V DC FOR A MINIMUM OF 10ms.
- IMPEDANCE: 100Ω DIFFERENTIAL.
- OTHER TESTING PERFORMED AS REQUIRED BY PRODUCT SPECIFICATION: GS-12-650.
- PACKAGE AND LABEL CABLE ASSEMBLIES PER GS-14-1272.
- A "△" SYMBOL WILL BE NEXT TO ANY DIMENSION, VIEW, OR NOTE WHICH HAS BEEN MODIFIED WITH THE CURRENT DRAWING REVISION. THE CURRENT REVISION WILL BE SHOWN IN THE SYMBOL.
- "HLF" PRODUCT NUMBERS DESIGNATE THE USE OF HALOGEN FREE RAW CABLE.
- HALOGEN FREE RAW CABLE CAN BE USED AS A SUBSTITUTE ON NON-HF PRODUCT NUMBERS.
- PART NUMBER/SUPPLIER SUBSTITUTION IS NOT ALLOWED.
- THIS PRODUCT CONFORMS TO THE MECHANICAL DIMENSIONING AND ELECTRICAL REQUIREMENTS OF THE SFF-8643 SPECIFICATION.

Amphenol FCI
© 2016 AFCI

spec ref	-	dr	David Lord	2011/12/15	projection	mm	size	A3	scale	2:1	
tolerance std	ISO 406 ISO 1101	eng	Ya LI	2018/01/16		← →	ecn no	ELX-N-29059-1			
TOLERANCES UNLESS OTHERWISE SPECIFIED		chr	-	-			rel level	Released			
surface	linear	appr	Caspar Lin	2018/01/24	product family	-	rel level	Released			
	0.X ±0.3	Amphenol FCI		mSAS HD INTERNAL (4i) CABLE ASSEMBLY- 12 Gb/s		dwg no		10119217		rev	
	0.XX ±0.10										
	0.XXX ±0.005										
ISO 1302	angular	0° ±2°	www.fci.com	cat. no.	-	Product - Customer Drw		sheet 4 of 4			

X-ON Electronics

Largest Supplier of Electrical and Electronic Components

Click to view similar products for [Computer Cables](#) category:

Click to view products by [Amphenol](#) manufacturer:

Other Similar products are found below :

[68809-0004](#) [8F36-AAA105-1.00](#) [IB63](#) [CB-716EB-RS](#) [CB-716P8P9-RS](#) [CBK-11-290K-00](#) [ACL-10550](#) [ACL-10568-2](#) [ACL-10568-5](#)
[427522400-3](#) [32102-021500-200-RS](#) [426091300-3](#) [48000023](#) [10114976-P015002LF](#) [88761-6101](#) [NT631C-CN321-EU](#) [ACL-10568NF-1](#)
[MIKROE-2092](#) [PCL-101100R-2E](#) [1700009405](#) [PS/2 Cable](#) [NT31C-CN323-EU](#) [FWAX-PK1-51](#) [PCL-10168H-1E](#) [68801-1905](#) [111068-1015](#)
[100436-1107](#) [68801-0630](#) [68801-3612](#) [68801-3618](#) [205058-1002](#) [PS2NK](#) [SATA cable](#) [96021-0000-00-0](#) [FAK-SMZSMZ 5M](#) [FAK-](#)
[SMZSMZ-3M](#) [ACC-500-200-R](#) [iW-C40-PCIe08-C1](#) [1700001531](#) [96048-0000-00-0](#) [SATA III cable 30cm, down/straight](#) [cab-Pico-ITX-](#)
[LVDS](#) [PCL-101100SB-2E](#) [AXXSTCBLQAT](#) [NT31C-KBA05](#) [PCL-101100M-2E](#) [A2U4PSWCXCXK1](#) [2 port SATA to 5 pin,L=200mm](#)
[ACL-10568NF-2](#) [C-PS2WG/5](#)