

REVISIONS			
LTR	DESCRIPTION	DATE	APPVD
A	INITIAL RELEASE NUM: 70097-412		
B	(CL 11) REMOVE Z PLATING DATA, ADDED X PLATING DATA ECN: 89224	J BORDEAU 3/1/01	

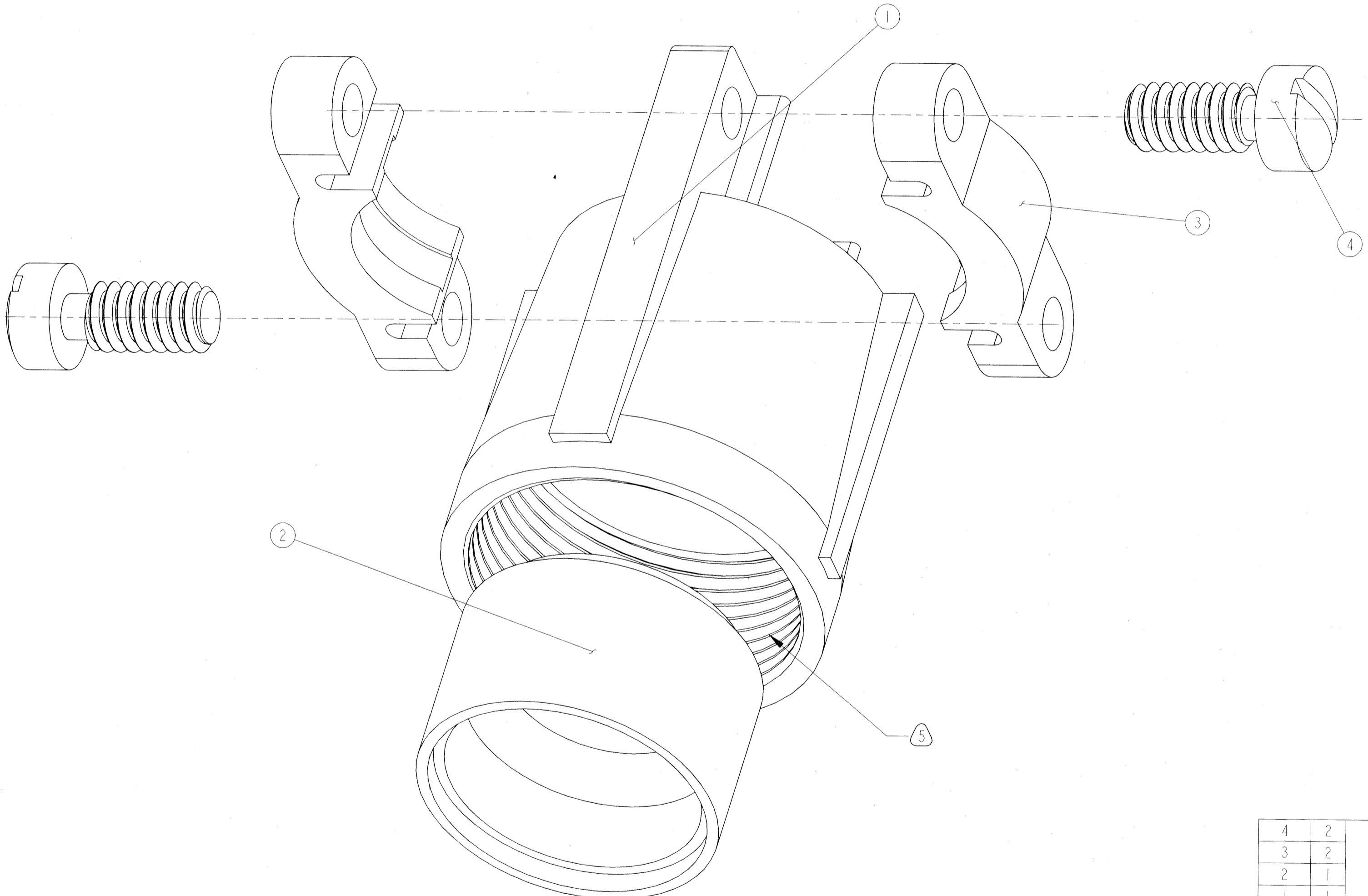

SEE SHEET 2.

NOTES:

THE USE OF THIS DOCUMENT IS UNLIMITED. HOWEVER, DOCUMENTS REFERENCED HEREON MAY CONTAIN LIMITED RIGHTS DATA.

COMPANY ID: 9	CODED/MS/CUST: N	MS3100F()
INTERNAL: Y	LOT NO: N	& OTHERS
DATE CODE: 9-3895	SEE DRAW: N	
STAMPING DATA		NEXT ASSEMBLY

UNLESS OTHERWISE SPECIFIED	SPECIFICATIONS	POS	QTY	PART NUMBER	DESCRIPTION	NOTE
LINEAR DIMENSIONS ARE IN INCHES TOLERANCES: .XXXX = ±.0005 .XXX = ±.010 .XX = ±.03 .X = ±.1 ANGLES = ±2° OTHER STANDARDS PER 9-3800 AND DOD-D-1000 THIRD ANGLE PROJECTION	MATERIAL SPEC.	4	2	SEE NOTE 1	SCREW	
	N/A	3	2		CLAMP BAR	
	PROCESS SPEC.	2	1		SLEEVE, COMPRESSION	
	9-3031, 9-3895	1	1		BACKSHELL	
PARTS LIST AMPHENOL CORPORATION <small>SIDNEY, N.Y. 13838</small> E / F CLASS ADAPTER KIT FOR MIL-C-5015						
APPROVALS PREPARED: OLESIK CHECKED: G. OLESIK MATERIAL: APPROVED: G. OLESIK		DATE 11-Nov-97 11/11/97 11/11/97		DOCUMENT NO. 10-584180/199		
APPROVED: 10-584180_199.ASSEM 10-584180_199		SIZE C	FSCM NO. 77820	REF: N/A	REV. B	SHEET 1 OF 2
SCALE: none						

AMPHENOL PART NUMBER	SIZE
10-584180-08()	8S
10-584181-10()	10S
10-584182-11()	10SL, 12S, 12
10-584185-14()	14S, 14
10-584187-16()	16S
10-584188-17()	16
10-584189-18()	18
10-584190-20()	20
10-584191-22()	22
10-584192-24()	24
10-584193-28()	28
10-584194-32()	32
10-584195-36()	36
10-584196-40()	40
10-584197/199-()	44/52

4

6. IDENTIFY PACKAGING WITH AMPHENOL PART NUMBER AND DATE CODE (PER 9-3895).

EXAMPLE:
10-584189-183 9747

5. LUBE THREADS WITH 9-3031.

4. TO COMPLETE PART NUMBER, ADD APPLICABLE LAST CHARACTER SUFFIX FOR DESIRED FINISH

FINISH	SUFFIX
CHROMATE TREAT PER 9-3350	-XX0
BRIGHT CADMIUM PLATE PER 9-2158	-XX1
BLACK ANODIZE PER 9-3487	-XX2
OLIVE DRAB CADMIUM PLATE PER 9-3047	-XX3
GREY ANODIZE PER 9-3487	-XX4
ANODIC COATING PER 9-3290	-XX5
CADMIUM PLATE, NICKEL BASE PLATE PER 9-4332	-XX7
BRIGHT NICKEL PLATE PER 9-3435	-XX8
O. D. CADMIUM PLATE, NICKEL BASE PLATE PER 9-4960	-XX9
NICKEL ALLOY PLATE PER 9-6914	-XXG
GREEN ZINC ALLOY PLATE PER 9-9263	-XXU
BLACK ZINC CONDUCTIVE ALLOY PLATE PER 9-9181-1	-XXX
BLACK ZINC ALLOY PLATE PER 9-9181	-XXY

3. PACKAGE PER PRODUCTION PROCESS SHEET.

2. SEE WORK ORDER FOR PERMISSIBLE ADDITIONAL OR ALTERNATE STAMPING.

1. SEE SEPARATE PARTS LIST FOR COMPONENT PART NUMBERS AND QUANTITIES.

NOTES:

THE USE OF THIS DOCUMENT IS UNLIMITED. HOWEVER, DOCUMENTS REFERENCED HEREON MAY CONTAIN LIMITED RIGHTS DATA.

SIZE C	FSCM NO. 77820	DOCUMENT NO. 10-584180/199	REV. B
SCALE: NONE	REF: N/A	SHEET 2 OF 2	

2 OF 2

10-584180/199

DOC NO

A

TAB.

X-ON Electronics

Largest Supplier of Electrical and Electronic Components

Click to view similar products for [Circular MIL Spec Tools, Hardware & Accessories](#) *category:*

Click to view products by [Amphenol](#) *manufacturer:*

Other Similar products are found below :

[0113-201-2025](#) [600-079-06](#) [600-146-06](#) [M10-101982-143](#) [M10-101982-163](#) [M10-101983-183](#) [M10-150912-083](#) [M10-454396-008](#)
[602GB18808](#) [CS3102A-22-14PW](#) [M2887615-CD](#) [627-009](#) [M38999/9-19B](#) [630A007NF083A](#) [630B007M051A](#) [630BJ003NF032H](#) [637-](#)
[149NF04B](#) [M39029/29-215](#) [6408-203V-09273](#) [6426-201-11343](#) [650FS002NF16](#) [660-008NF14S7-01](#) [660-009M22H8-03](#) [660-013NF19U6-](#)
[210](#) [660-015M10S6-17](#) [660-015NF10S5-01](#) [660-015NF14R3.5-01](#) [660-023NF19H6-19](#) [660-024NF11S12-01](#) [660-024NF11S3-01](#) [660-](#)
[024NF17S4-109](#) [660-050XM17F4-01](#) [660-068NF25R6-30G](#) [660-070M23S8-04](#) [660-073MTCH9-20](#) [M83723/61-18W](#) [M83723/61-218R](#)
[M83723/61-224W](#) [667-084-23C](#) [667-084-35C](#) [667-224NF16](#) [687-697NF-1](#) [M85049/94-10-A](#) [M85049/96-7-A](#) [M855282-10A01A](#)
[M85528/2-10B](#) [M855282-18A01A](#) [M85528/2-22A01A](#) [M85528/2-22AA](#) [710HS460NF2508](#)