

PRODUCT NUMBER
20020303-XXXXXXLF

20020303-□ □ □ □ B 0 □ L F

PITCH

D: 3.81 mm
G: 5.00 mm
H: 5.08 mm

POLES

02: 2 POLES
03: 3 POLES
.....
24: 24 POLES

LF : DENOTED RoHS COMPATIBLE

1 : STANDARD PRODUCT
W/ BOX PACKING

HOUSING CODE

CODE	COLOR	AVAILABILITY
1	GREEN(RAL 6018/T)	STANDARD
2	BLACK	ON REQUEST ONLY
3	GREY(RAL 7004/P)	ON REQUEST ONLY
4	BLUE(RAL 5015/A)	ON REQUEST ONLY

PROPERTY TABLE				
FCI SERIES NAME		09-381	09-500	09-508
PITCH (mm)		3.81	5.00	5.08
VOLTAGE RATING (VAC)		300	300	300
CURRENT RATING (A)		6	10	10
APPLICABLE WIRE RANGE (AWG)	1-WIRE	16~26	14~24	14~24
	2-WIRE	NA	NA	NA
WIRE CROSS SECTION (mm ²)	SOLID	1-WIRE	1.0	1.5
		2-WIRE	NA	NA
	STRANDED	1-WIRE	1.0	1.5
		2-WIRE	NA	NA
OPENING CONTACT HOUSING(mm ²)		1.7x1.7	2.4x2.4	2.4x2.4
WIRE STRIP LENGTH(mm)		9~10	9~10	9~10
WITHSTANDING VOLTAGE (kV)		1.6	1.6	1.6
OPERATING TEMP. (°C)		-40~+115	-40~+115	-40~+115
SOLDERING TEMP. (°C)		250±10 (5 sec.)	250±10 (5 sec.)	250±10 (5 sec.)
POLES AVAILABLE		02~24	02~24	02~24
SAFETY CERTIFICATE				

NOTES:

- MATERIALS
 - 1-1 TERMINAL BODY: THERMALPLASTIC RESIN, UL 94V-0 RATED.
 - 1-2 TERMINAL COVER: THERMALPLASTIC RESIN, UL 94V-0 RATED.
 - 1-3 TERMINAL LEVER: THERMALPLASTIC RESIN, UL 94V-0 RATED.
 - 1-5 TERMINAL: COPPER ALLOY, TIN PLATED.
 - 1-6 SPRING CLAMP: STAINLESS STEEL.
- PRODUCT SPECIFICATION REFER TO FCI GS-12-625.
- PRODUCT PACKING SPECIFICATION REFER TO FCI GS-14-1394.
- FCI, SAFETY CERTIFICATE LOGO AND SERIES NAME TO BE SHOWN ON PRODUCT SURFACE.
- THE PRODUCTS WHERE THE PART NUMBER END IN "LF" MEET THE EUROPEAN UNION DIRECTIVE AND OTHER COUNTRY REGULATIONS AS DESCRIBED IN GS-22-008.
- RECOMENDED SOLDERING PROCESS BY WAVE SOLDER.

mat'l. code		surface ASME Y14.5 ✓		tolerance ASME Y14.5		projection		product family	
ltr		ecn no	dr	date		tolerances unless otherwise specified		TERMINAL BLOCK	
A	T10-0191	WL		122010		X.±0.5		title	
B	T11-0012	WL		021711		X.X±0.3		TERMINAL BLOCK	
C	T-005281	WL		082311		X'±1"		FIXED SIGNAL PLUG, RIGHT ANGLE WIRE INLET	
				dr		WENDY CHEN		110910	
				enr		JASON HSU		110910	
				chr		JASON HSU		110910	
				appd		JASON HSU		110910	
sheet index		revision	C	C	C	C	C	FCI	
		sheet	1	2	3	4		dwg no	
								sheet 1 of 4 size	
								20020303	
								A4	
								type	
								CUSTOMER Drawing	



PRODUCT NUMBER	SERIES NAME	PITCH
20020303-DXXXXXL	09-381	3.81 mm

N = Number of poles
 Dim L = $N \times 3.81 [.150] + 2.5 [.098]$
 Dim P = $(N - 1) \times 3.81 [.150]$

POLES	Dim L	Dim P
2-6P	$\pm 0.15 [.006]$	$\pm 0.10 [.004]$
7-12P	$\pm 0.20 [.008]$	$\pm 0.20 [.008]$
13-18P	$\pm 0.30 [.012]$	$\pm 0.25 [.010]$
19-24P	$\pm 0.40 [.016]$	$\pm 0.30 [.012]$

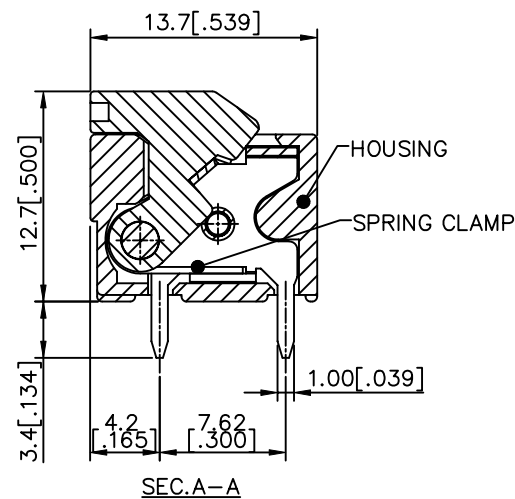
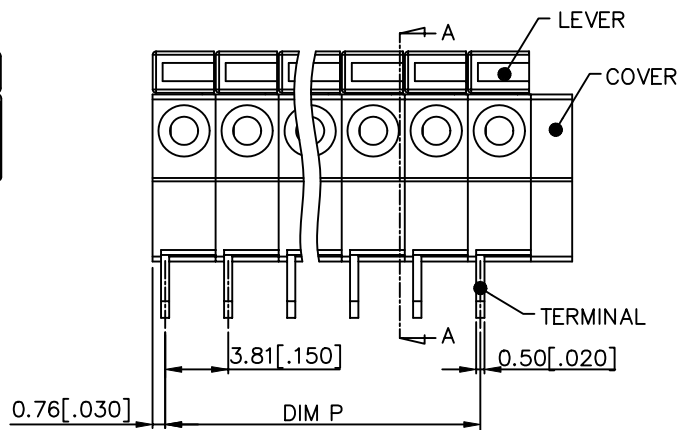
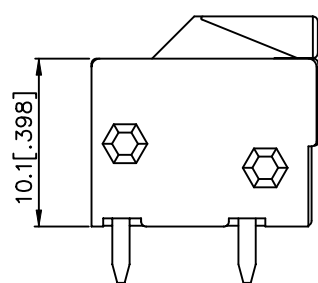
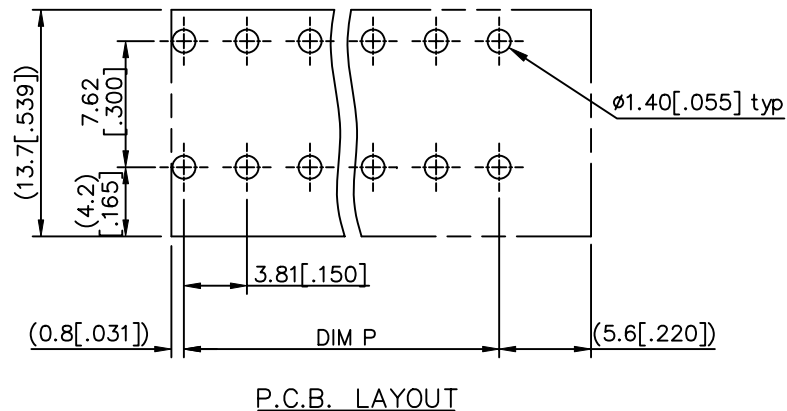
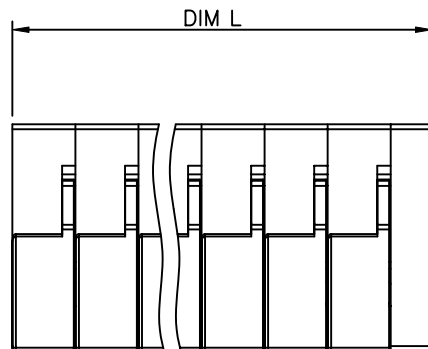

mat'l. code	surface ASME Y14.5	tolerance ASME Y14.5	projection	product family
ltr	ecn no	dr	date	TERMINAL BLOCK
tolerances unless otherwise specified				title
angles				TERMINAL BLOCK
X°±1'				FIXED SIGNAL PLUG, RIGHT ANGLE WIRE INLET
scale				dwg no
dr WENDY CHEN 110910				sheet 2 of 4 size
enr JASON HSU 110910				20020303
chr JASON HSU 110910				A4
appd JASON HSU 110910				type
				CUSTOMER Drawing
sheet index	revision sheet			



PRODUCT NUMBER	SERIES NAME	PITCH
20020303-GXXXXXXLF	09-500	5.00 mm

N = Number of poles
 Dim L = $N \times 5.0[.197] + 2.54[.100]$
 Dim P = $(N-1) \times 5.0[.197]$

POLES	Dim L	Dim P
2-6p	$\pm 0.15[.006]$	$\pm 0.10[.004]$
7-12p	$\pm 0.20[.008]$	$\pm 0.20[.008]$
13-18p	$\pm 0.30[.012]$	$\pm 0.25[.010]$
19-24p	$\pm 0.40[.016]$	$\pm 0.30[.012]$

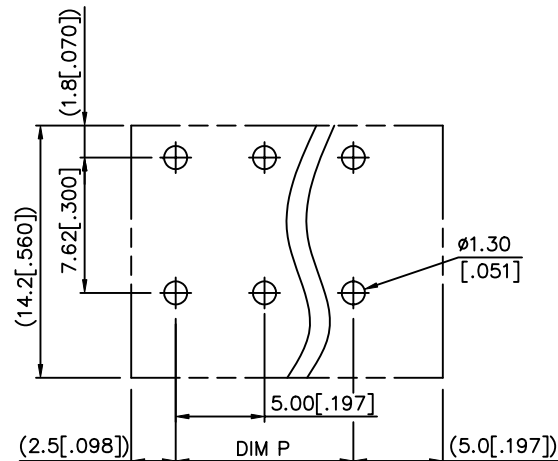
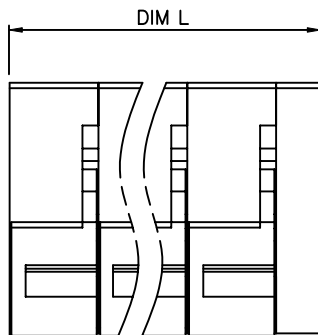

P.C.B. LAYOUT

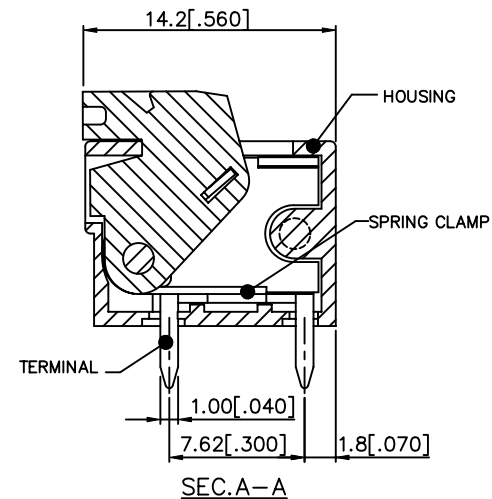
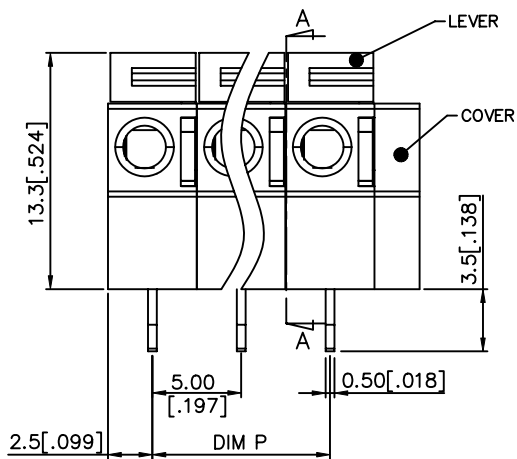
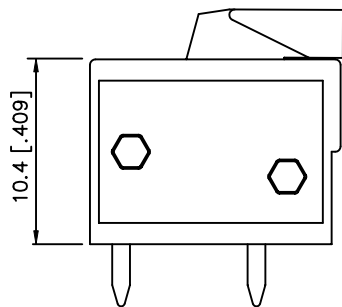

SEC. A-A

mat'l. code		surface ASME Y14.5	tolerance ASME Y14.5	projection 	product family TERMINAL BLOCK
ltr	ecn no	dr	date	title TERMINAL BLOCK FIXED SIGNAL PLUG, RIGHT ANGLE WIRE INLET	
C		angles	$X \pm 0.5$	MM [INCH]	dwg no 20020303 sheet 3 of 4 size A4
		$X \pm 1^\circ$	$X.X \pm 0.3$	scale	
		dr	WENDY CHEN 110910		type CUSTOMER Drawing
		enr	JASON HSU 110910		
		chr	JASON HSU 110910		
		appd	JASON HSU 110910		
sheet index	revision sheet				

PRODUCT NUMBER	SERIES NAME	PITCH
20020303-HXXXXXLf	09-508	5.08 mm

N = Number of poles
 Dim L = $N \times 5.08 [.200] + 2.54 [.100]$
 Dim P = $(N - 1) \times 5.08 [.200]$

POLES	Dim L	Dim P
2-6p	$\pm 0.15 [.006]$	$\pm 0.10 [.004]$
7-12p	$\pm 0.20 [.008]$	$\pm 0.20 [.008]$
13-18p	$\pm 0.30 [.012]$	$\pm 0.25 [.010]$
19-24p	$\pm 0.40 [.016]$	$\pm 0.30 [.012]$

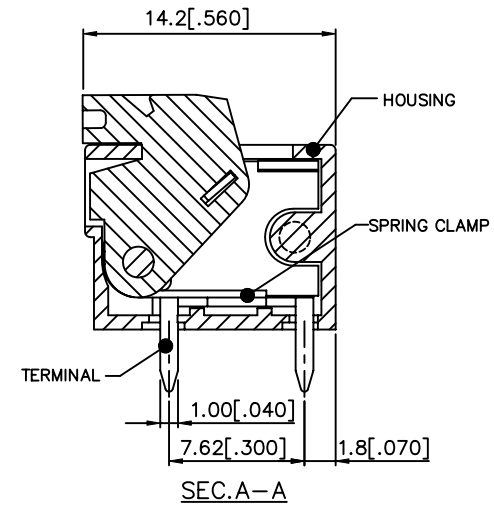
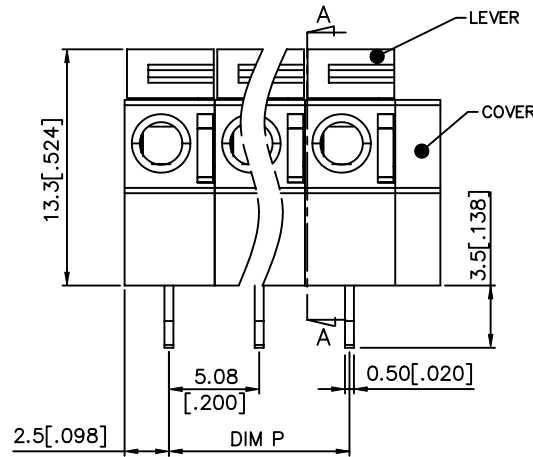
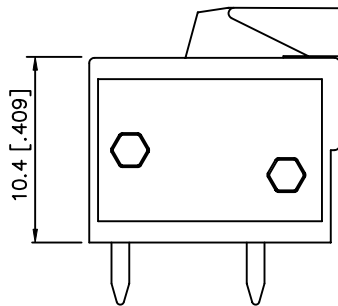
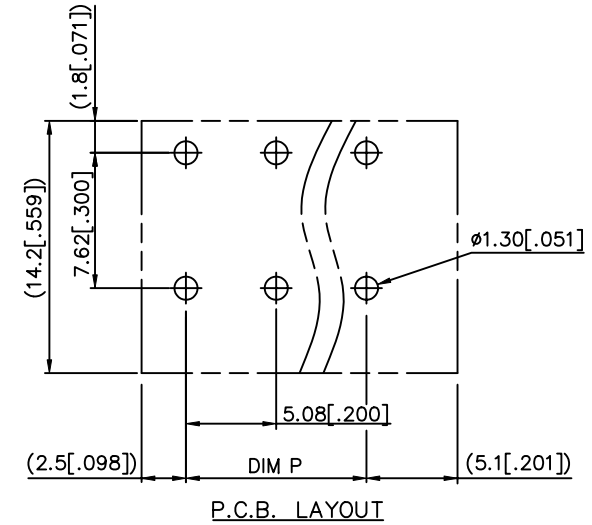
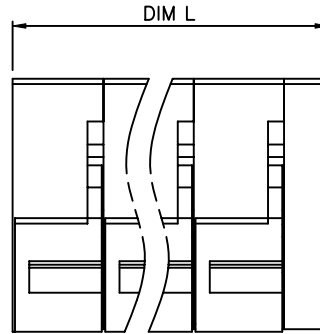

mat'l. code	surface ASME Y14.5	tolerance ASME Y14.5	projection 	product family TERMINAL BLOCK
ltr	ecn no	dr	date	title
tolerances unless otherwise specified				TERMINAL BLOCK FIXED SIGNAL PLUG, RIGHT ANGLE WIRE INLET
angles		$X \pm 0.5$	MM	
X°±1'		$X.X \pm 0.3$	[INCH]	
		$X.XX \pm 0.1$	scale	dwg no
dr		WENDY CHEN	110910	sheet 4 of 4 size
enr		JASON HSU	110910	20020303
chr		JASON HSU	110910	
appd		JASON HSU	110910	A4
sheet index		revision sheet	type CUSTOMER Drawing	

X-ON Electronics

Largest Supplier of Electrical and Electronic Components

Click to view similar products for [Fixed Terminal Blocks](#) category:

Click to view products by [Amphenol](#) manufacturer:

Other Similar products are found below :

[00175550202](#) [MBE-1512](#) [MBE-1520](#) [MBE-154](#) [MBE-156](#) [MBES-1510](#) [MBES-153](#) [MBES-156](#) [MH-2512](#) [MHE-132](#) [MHE-133](#) [MHE-163](#)
[MI-254 \(35\)](#) [MI-272](#) [8739](#) [880507](#) [880508](#) [MPT-275](#) [1546551-6](#) [ELM023100](#) [ELM10110G](#) [ELVD12100](#) [BA311TU](#) [BA411SU](#) [MV-152](#)
[MV-253/NCNOC](#) [MV-254-D](#) [MV-255](#) [MV-462](#) [MV-472](#) [MV-493](#) [MVE-252](#) [MVE-253](#) [MVE-258](#) [MVE-273](#) [MVEB-153](#) [1700096](#)
[1702246](#) [1705142](#) [1712417](#) [1713020](#) [1713088](#) [1776118-2](#) [1790852](#) [1-796689-8](#) [1-796692-6](#) [1800001](#) [1800114](#) [1823215](#) [1838462](#)