

PRODUCT NUMBER
20020327-XXXXXXLF

20020327-□ □ □ □ □ 0 □ L F

PITCH
C: 3.50 mm
D: 3.81 mm

POLES
02: 2 POLES
03: 3 POLES
04: 4 POLES
24: 24 POLES

LF : DENOTED RoHS COMPATIBLE
1 : STANDARD PRODUCT
W/ BOX PACKING

SCREW CODE

CODE	SCREW TYPE	AVAILABILITY
A	-/+	ON REQUEST ONLY
B	-	STANDARD

PROPERTY TABLE			
FCI SERIES NAME		26-350	26-381
PITCH (mm)		3.50	3.81
VOLTAGE RATING (VAC)		300	300
CURRENT RATING (A)		10	10
APPLICABLE WIRE RANGE (AWG)	1-WIRE	16~24	16~24
	2-WIRE	20	20
WIRE CROSS SECTION (mm ²)	SOLID	1-WIRE	1.5
		2-WIRE	0.5
	STRANDED	1-WIRE	1.0
		2-WIRE	0.2
OPENING CONTACT HOUSING(mm ²)		1.6x1.6	1.6x1.6
WIRE STRIP LENGTH(mm)		5~6	5~6
TORQUE +/-10% (N-m/Lb-in)		0.19/1.7	0.19/1.7
SCREW		M2x0.4	M2x0.4
WITHSTANDING VOLTAGE (kV)		1.6	1.6
OPERATING TEMP. (°C)		-40~+115	-40~+115
SOLDERING TEMP. (°C)		250±10 (5 sec.)	250±10 (5 sec.)
POLES AVAILABLE		02~24	02~24
SAFETY CERTIFICATE			

HOUSING CODE

CODE	COLOR	AVAILABILITY
1	GREEN(RAL 6018/T)	STANDARD
2	BLACK	ON REQUEST ONLY
3	GREY(RAL 7004/P)	ON REQUEST ONLY
4	BLUE(RAL 5015/A)	ON REQUEST ONLY

NOTES:

- MATERIALS**
 1-1 HOUSING: THERMALPLASTIC RESIN, UL 94V-0 RATED.
 1-2 SCREW: STEEL, ZINC PLATED.
 1-3 CLAMP: COPPER ALLOY, NICKEL PLATED.
 1-4 TERMINAL: COPPER ALLOY, TIN PLATED.
 2. PRODUCTION SPECIFICATION REFER TO FCI GS-12-625.
 3. BOXED PACKAGING.
 DETAILED PRODUCT PACKING SPECIFICATION REFER TO FCI GS-14-1394.
 4. FCI, SAFETY CERTIFICATE LOGO AND SERIES NAME TO BE SHOWN ON PRODUCT SURFACE.
 5. THE PRODUCTS WHERE THE PART NUMBER END IN "LF" MEET THE EUROPEAN UNION DIRECTIVE AND OTHER COUNTRY REGULATIONS AS DESCRIBED IN GS-22-008.
 6. RECOMENDED SOLDERING PROCESS BY WAVE SOLDER.

mat'l. code				surface ASME Y14.5	tolerance ASME Y14.5	projection	product family	
tolerances unless otherwise specified				tolerances unless otherwise specified			TERMINAL BLOCK	
ltr	ecn no	dr	date	angles	tolerance	MM [INCH]	title	
A	0609-0203	BF	062509	X±0.5	X.X±0.3	scale	TERMINAL BLOCK FIXED HORIZONTAL WIRE INLET	
B	T09-1148	BF	111709	X*±1*	X.XX±0.1			
C	T09-1152	BF	112609					
D	T10-0042	WL	030310	dr	BEER FU	062509	dwg no	
E	T10-0109	WL	070710	enr	BEER FU	062509	sheet 1 of 3	
F	T10-0159	WL	100410	chr	GARY HSIEH	062509	20020327	
G	T10-0187	WL	121410	appd	JOSEPH HSIA	062509	A4	
sheet		revision	G	G	type			CUSTOMER Drawing
index	sheet	1	2	3				



PRODUCT NUMBER	SERIES NAME	PITCH
20020327-CXXXXXLf	26-350	3.50 mm

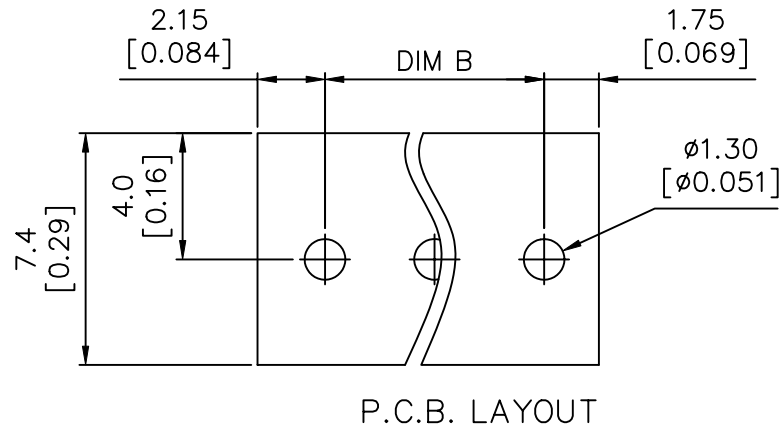
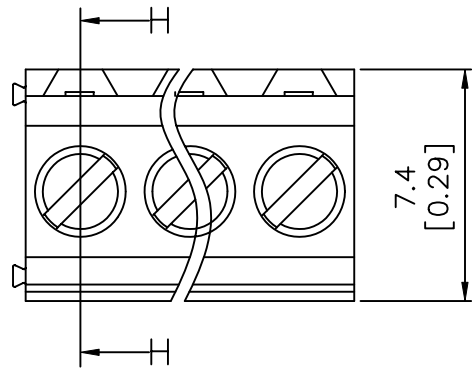

P.C.B. LAYOUT

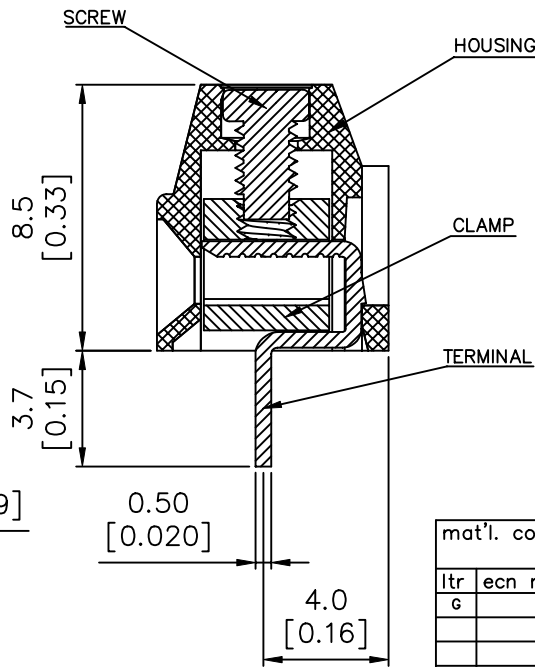
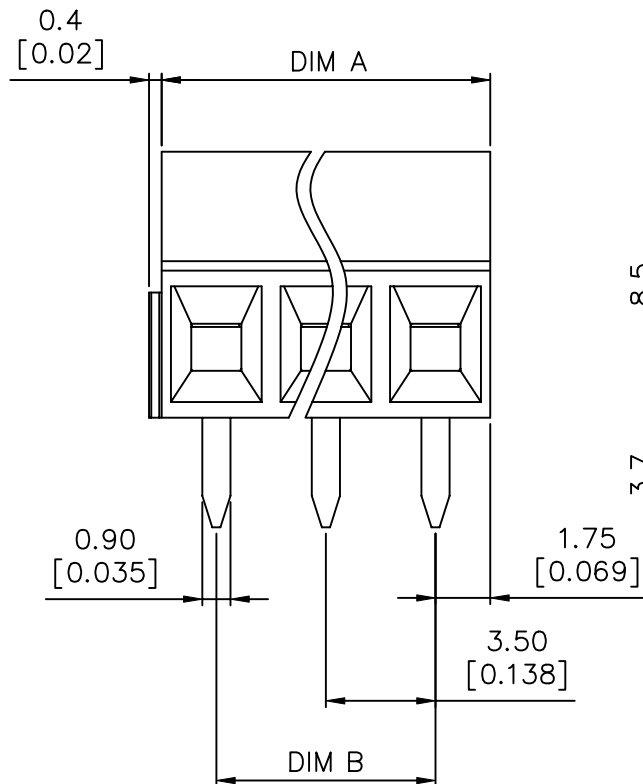

SECTION H-H

N = Number of poles
 Dim A = $N \times 3.5 [0.138]$
 Dim B = $(N-1) \times 3.5 [0.138]$

TOL.	Dim A	Dim B
2-6p	$\pm 0.15 [0.006]$	
7-12p	$\pm 0.20 [0.008]$	
13-16p	$\pm 0.25 [0.010]$	
17-24p	$\pm 0.30 [0.012]$	

mat'l. code		surface ASME Y14.5	tolerance ASME Y14.5	projection 	product family TERMINAL BLOCK
ltr	ecn no	dr	date	title TERMINAL BLOCK FIXED HORIZONTAL WIRE INLET	
g				 MM [INCH]	dwg no 20020327
				scale	sheet 2 of 3 size A4
		dr	BEER FU	062509	 type CUSTOMER Drawing
		enr	BEER FU	062509	
		chr	GARY HSIEH	062509	
		appd	JOSEPH HSIA	062509	
sheet index	revision sheet				



PRODUCT NUMBER	SERIES NAME	PITCH
20020327-DXXXXXL	26-381	3.81 mm

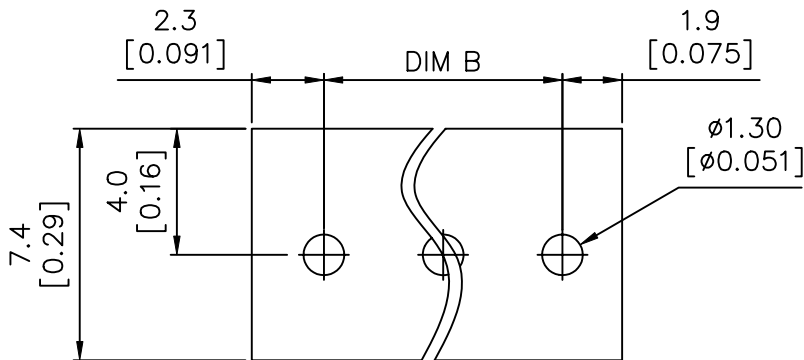
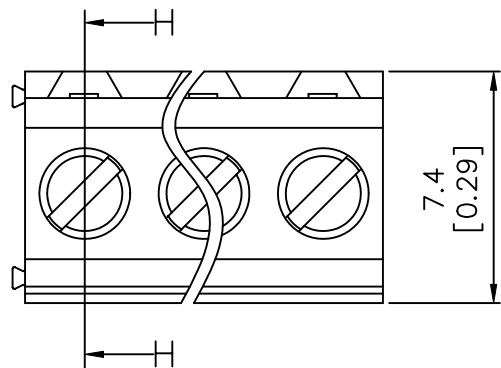

P.C.B. LAYOUT

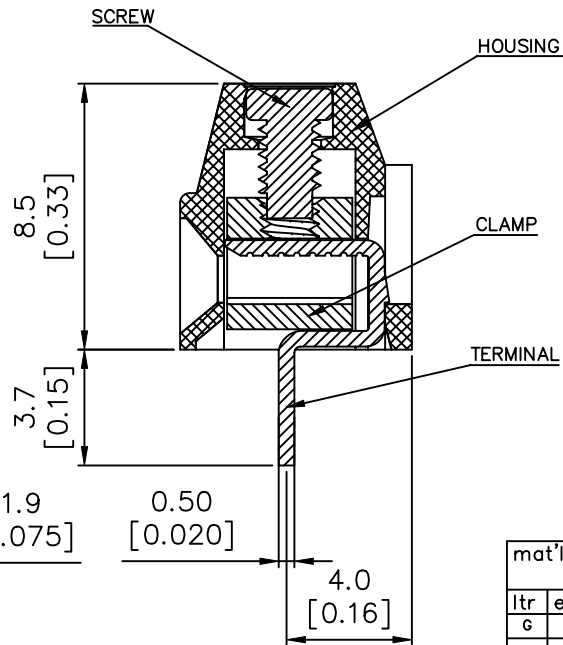
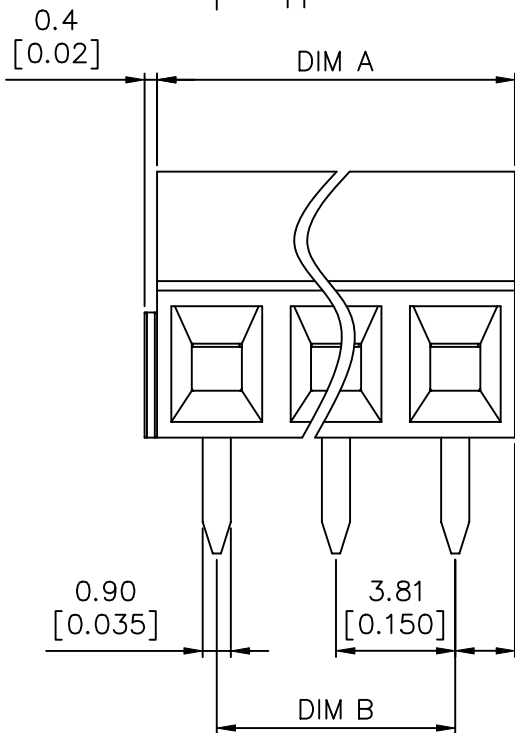

SEC H-H

N = Number of poles
 Dim A = $N \times 3.81 [0.150]$
 Dim B = $(N - 1) \times 3.81 [0.150]$

TOL.	Dim A	Dim B
2-6p	$\pm 0.15 [0.006]$	
7-12p	$\pm 0.20 [0.008]$	
13-16p	$\pm 0.25 [0.010]$	
17-24p	$\pm 0.30 [0.012]$	

mat'l. code		surface ASME Y14.5	tolerance ASME Y14.5	projection 	product family TERMINAL BLOCK
ltr	ecn no	dr	date	tolerances unless otherwise specified	title
g				angles X \pm 1°	TERMINAL BLOCK FIXED HORIZONTAL WIRE INLET
				line X.XX \pm 0.1	scale MM [INCH]
		dr	BEER FU 062509		dwg no
		enr	BEER FU 062509		20020327
		chr	GARY HSIEH 062509		sheet 3 of 3 size A4
		appd	JOSEPH HSIA 062509		type CUSTOMER Drawing
sheet index	revision sheet				



X-ON Electronics

Largest Supplier of Electrical and Electronic Components

Click to view similar products for [Fixed Terminal Blocks](#) category:

Click to view products by [Amphenol](#) manufacturer:

Other Similar products are found below :

[MBE-1512](#) [MBE-154](#) [MBE-156](#) [MBES-153](#) [MBES-156](#) [MH-2512](#) [MHE-132](#) [MHE-163](#) [MI-254 \(35\)](#) [MI-272](#) [880507](#) [MPT-275](#)
[15602-04-08-21](#) [BA311TU](#) [BA411SU](#) [MV-152](#) [MV-252-D](#) [MV-253/NCNOC](#) [MV-254-D](#) [MV-255](#) [MV-462](#) [MV-493](#) [MVE-252](#) [MVE-253](#)
[MVE-273](#) [MVEB-153](#) [1700096](#) [1705142](#) [1745195](#) [1760594](#) [1776118-2](#) [1-796689-8](#) [1-796692-6](#) [20020314-C121B01LF](#) [CB2-12](#)
[KP03215000J0G](#) [KP04215000J0G](#) [S451](#) [282802-2](#) [29.007](#) [29.116](#) [30.103](#) [30.106](#) [30.252](#) [30.503](#) [30.608](#) [30.753](#) [30.755](#) [30.756](#) [30.853](#)