

NOTES:

1. MATERIALS AND FINISHES:  
 HEX NUT - BRASS, WHITE BRONZE PLATING  
 LOCK WASHER - BRASS, WHITE BRONZE PLATING  
 BODY - BRASS, WHITE BRONZE PLATING  
 OUTER CONTACT - PHOSPHOR BRONZE, WHITE BRONZE PLATING  
 CONTACT - BERYLLIUM COPPER, SILVER PLATING  
 GASKET - SILICONE RUBBER, RED  
 INSULATOR - PTFE, NATURAL  
 INSULATOR DISC - ULTEM, NATURAL
2. ELECTRICAL:  
 A. IMPEDANCE: 50 OHM  
 B. FREQUENCY RANGE: DC - 6 GHz  
 C. VSWR(RETURN LOSS): 30 dB @ DC - 6 GHz  
 D. DIELECTRIC WITHSTANDING VOLTAGE: 1500 VRMS, MIN.  
 E. INSULATION RESISTANCE: 3000MΩ MIN.  
 F. INTERMODULATION 3rd ORDER: -166dBc @2X20W
3. MECHANICAL:  
 A. DURABILITY: 100 CYCLES MIN.  
 B. TEMPERATURE RANGE: -65° C TO +165° C  
 C. BULKHEAD - IP-68  
 INTERFACE - IP-68 IN THREADED MATED CONDITION
4. SHOWS CABLE ENTRY DIMENSIONS
5. PACKAGING:  
 A. QUANTITY: SINGLE PACK  
 B. MARKING: PACKAGING TO BE MARKED  
 "AMPHENOL RF, 225-108J-52S & DATE CODE"
6. ASSEMBLY INSTRUCTIONS  
 A. FOR SEMI-RIGID CABLE, THERMALLY CYCLE ACCORDING TO MANUFACTURERS SPECIFICATIONS  
 B. STRIP CABLE AND INSERT THROUGH SHRINK TUBE AND BODY ASSEMBLY  
 C. INSERT INSULATOR DISC OVER CENTER CONDUCTOR AND SOLDER CONTACT ASSEMBLY. ALL COMPONENTS SHOULD BE FLUSH.  
 D. PRESS CONTACT ASSEMBLY INTO BODY ASSEMBLY UNTIL CONTACT ASSEMBLY BOTTOMS.  
 E. SOLDER BODY ONTO CABLE. 250 WATT SOLDERING IRON RECOMMENDED. USE OF FLUX RECOMMENDED.

THIRD ANGLE PROJ.

REVISIONS

REV	DESCRIPTION	DATE	ECN	APPR
A	RELEASE TO MANUFACTURING	07-Aug-19	12482	CJV

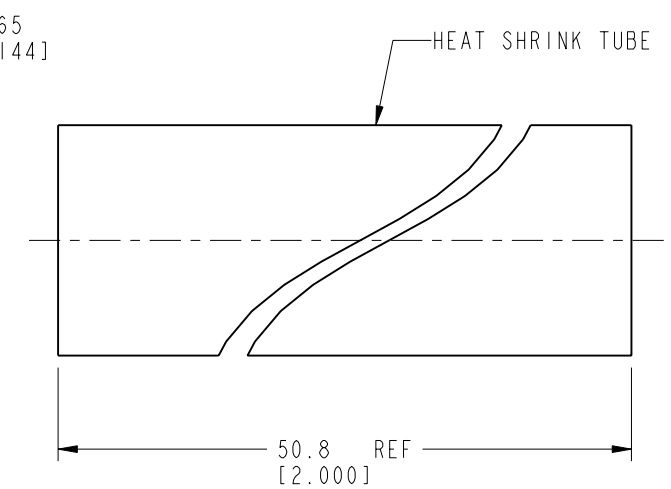
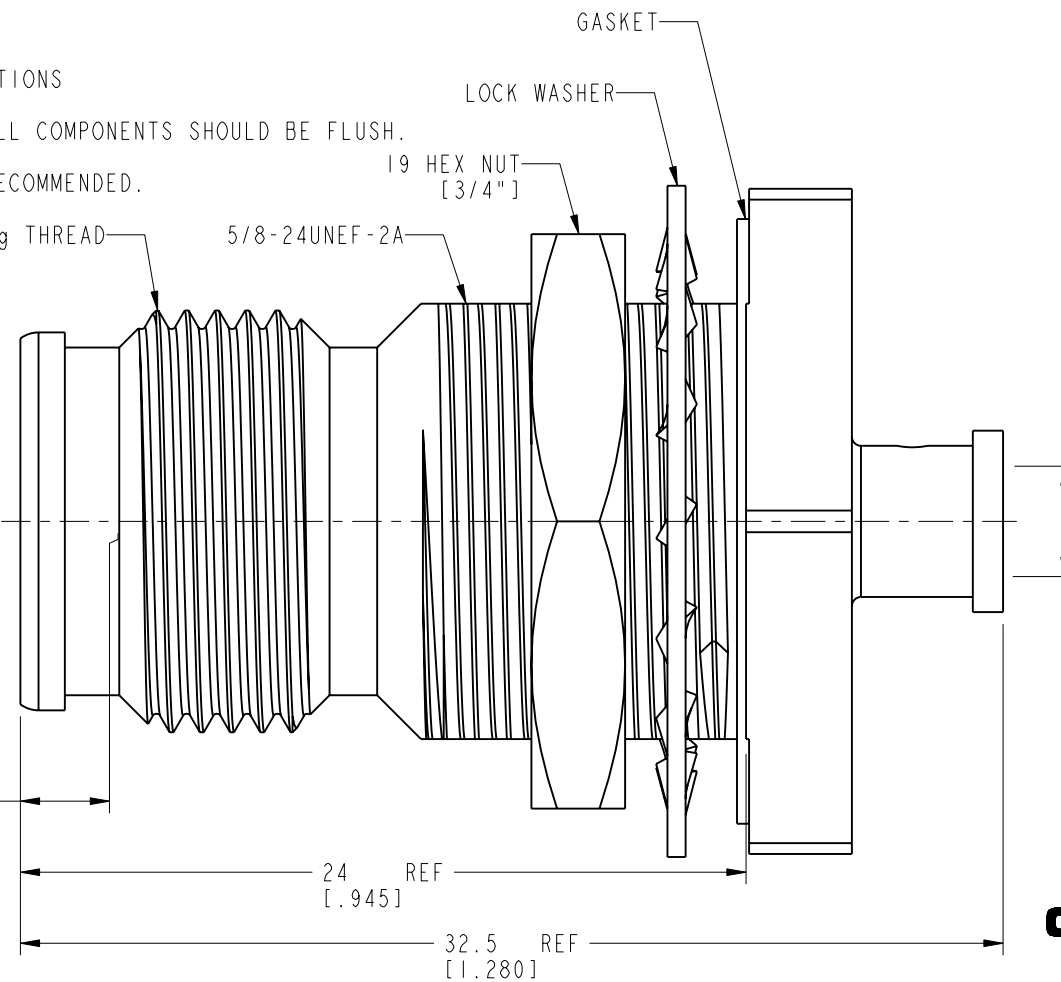
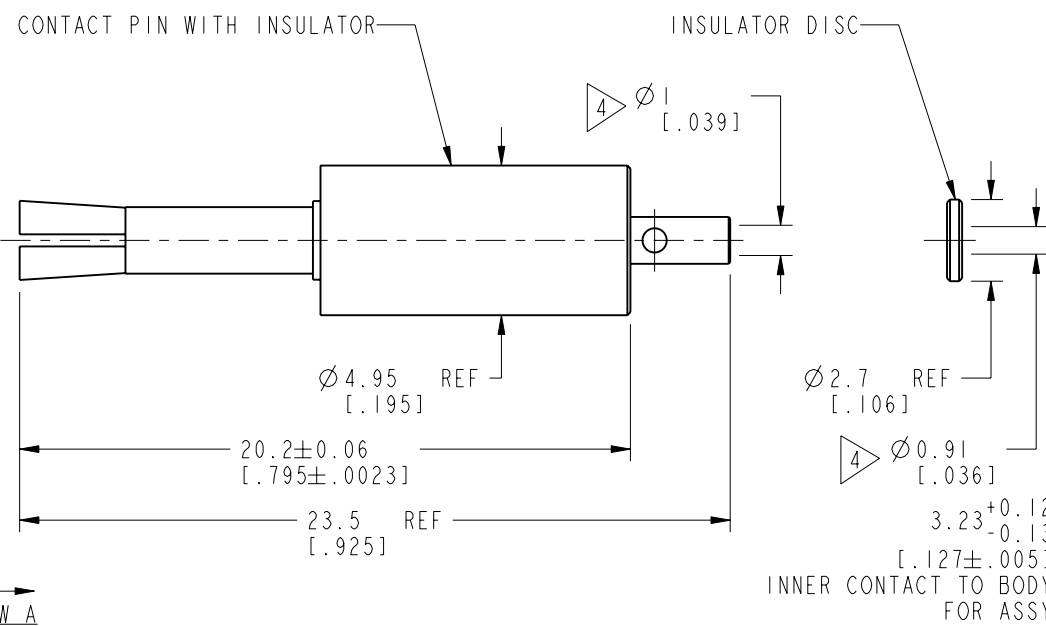
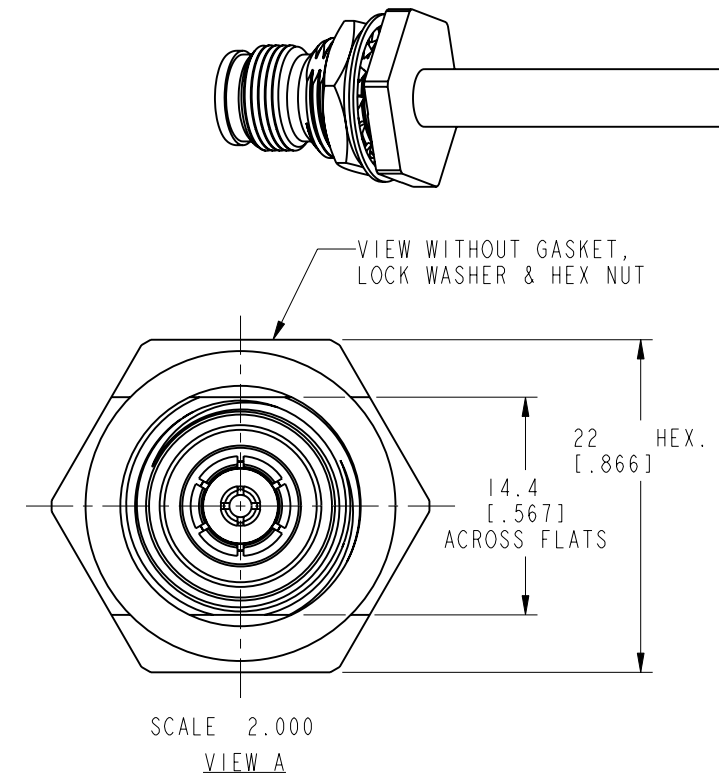
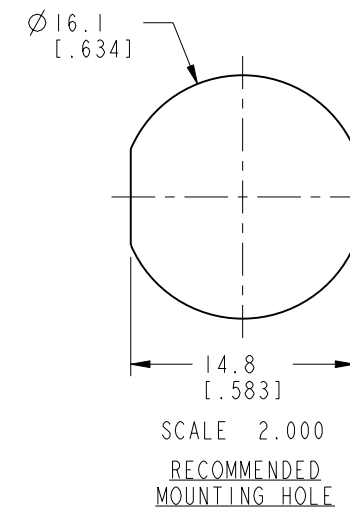
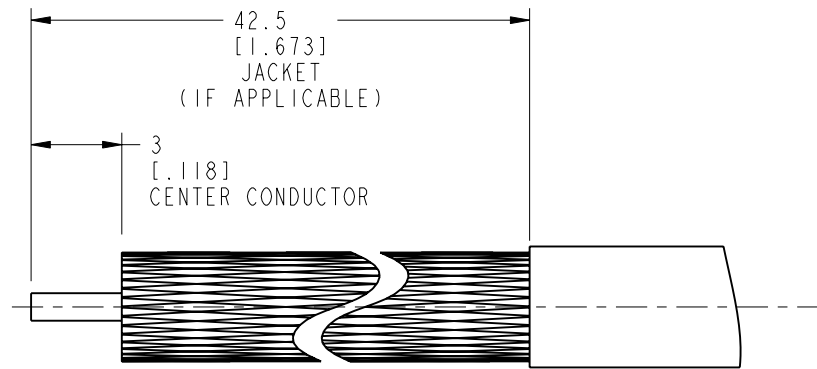

**CUSTOMER OUTLINE DRAWING**  
 ALL OTHER SHEETS ARE FOR INTERNAL USE ONLY

UNLESS OTHERWISE SPECIFIED, DIMENSIONS ARE IN METRIC AND TOLERANCES ARE:  
 <0.5mm ±0.05mm    0.5 - 6mm ±0.1mm    6 - 30mm ±0.2mm    30 - 120mm ±0.3mm    ANGLES ±1°

NOTICE - These drawings, specifications, or other data (1) are, and remain the property of Amphenol corp. (2) must be returned upon request; and (3) are confidential and not to be disclosed to any person other than those to whom they are given by Amphenol Corp. the furnishing of these drawings, specifications, or other data by Amphenol Corp., or to any other person to anyone for any purpose is not to be regarded by implication or otherwise in any manner licensing, granting rights to permitting such holder or any other person to manufacture, use or sell any product, process or design, patented or otherwise, that may in any way be related to or disclosed by said drawings, specifications, or other data.

MATERIAL	SEE NOTES
REFERENCE	EAR# 8104
REF:	---
CONFIGURATION LEVEL:	In Work
FINISH	

DRAWN	M. ZHANG	DATE	07-Aug-19
ENGINEER	C. VIGORITO	DATE	27-Sep-18
APPROVED	S. HSIEH	DATE	13-Aug-19
CAD FILE			

TITLE	
2.2-5 BULKHEAD JACK FOR .141" SEMI-RIGID & CONFORMABLE	
SCALE: 4.0:1.0	SHEET 2 OF 2
DWG SIZE	REV
B	A

Amphenol RF	
www.amphenolrf.com	
DRAWING NO. 225-108J-52S	
ITEM NO. 225-108J-52S	
PART NO. 225-108J-52S	

## X-ON Electronics

Largest Supplier of Electrical and Electronic Components

*Click to view similar products for [RF Connectors / Coaxial Connectors](#) category:*

*Click to view products by [Amphenol](#) manufacturer:*

Other Similar products are found below :

[8915-1511-000](#) [89674-0827](#) [6001-7071-019](#) [6002-7051-003](#) [6002-7551-202](#) [6059674-1](#) [619550-1](#) [630059-000](#) [M39030/3-01N](#) [M3933/25-36N](#) [6500-7071-046](#) [6769](#) [CX050L2AQ](#) [7002-1542-011](#) [7004-1512-000](#) [7009-1511-004](#) [7010-1511-000](#) [7029-1511-060](#) [7101-1541-010](#) [7101-1571-002](#) [7105-1521-002](#) [7145-1521-002](#) [7203-1571-003](#) [7209-1511-011](#) [7210-1511-015](#) [7210-1511-019](#) [73137-5015](#) [73216-2241](#) [7325-1512-000](#) [73404-2300](#) [7405-1521-005](#) [7405-1521-802](#) [7406-1521-005](#) [8527](#) [8547](#) [FS11V](#) [8808-1511-001](#) [9049-9513-000](#) [9074-9513-000](#) [9101-9573-002](#) [910A205F](#) [9130-9573-002](#) [PL11SC-026](#) [PL375-33](#) [PL40-5](#) [PL71-9](#) [PL74C-221](#) [PL75MC-217](#) [PL803-7](#) [980-8666-005](#)