

NOTES:

1. MATERIALS AND FINISHES:
 BODY - BRASS, SILVER PLATING.
 CONTACT - BRASS, GOLD PLATING.
 INSULATOR - PTFE
2. MECHANICAL:
 A. DURABILITY: 500 CYCLES MIN.
 B. TEMPERATURE RANGE: -65° C TO +165° C
3. PACKAGING:
 A. QUANTITY: SINGLE PACK
 B. MARKING: BAG TO BE MARKED
 "AMPHENOLRF, 31-4326 AND DATE CODE"
4. HEAT SHRINK TUBING SUPPLIED ON REQUEST. (68180-1)
5. ASTERISK (*) SHOWS CABLE ENTRY DIMENSIONS.
6. CUSTOMER NOTE: SOLDER CONTACT TO CABLE.
 WHEN CRIMPING CONTACT TO CABLE, CRIMP WITH AMPHENOL TOOL 227-944 (M22520/5-01) AND DIE SET 227-1221-11, CAVITY 'B' (M22520/5-11, CLOSURE 'B').
7. CRIMP WITH AMPHENOL TOOL 227-944 (M22520/5-01) AND DIE SET 227-1221-11, CAVITY 'A' (M22520/5-11, CLOSURE 'A').

31-4326		REVISIONS			
DRAWING NO.	REV	DESCRIPTION	DATE	ECO	APPR
THIRD ANGLE PROJ.	--	RELEASE TO MFG.	-----	-----	-----
	N	REDRAWN IN PROE, ADD COD	1/14/13	48616	PNE
	P	SEE SHEET 1	3/6/13	49452	CPM

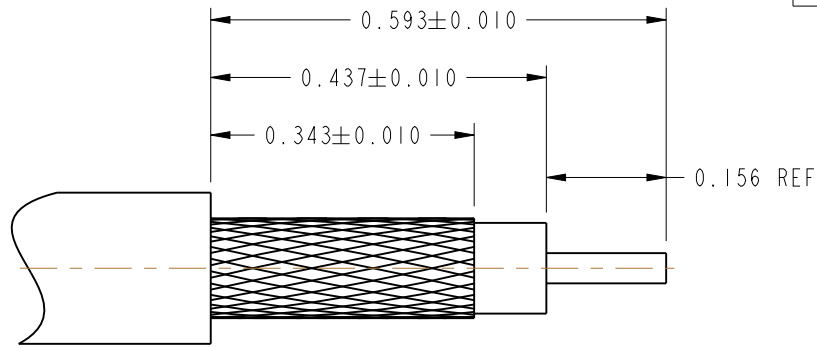

RECOMMENDED CABLE STRIPPING DIMENSIONS

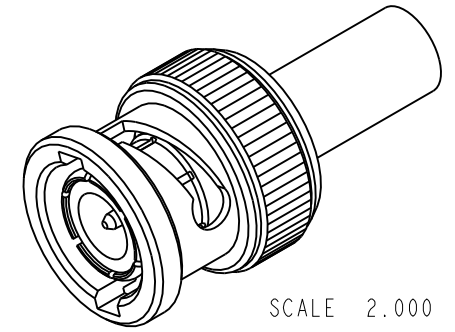

SCALE 2.000

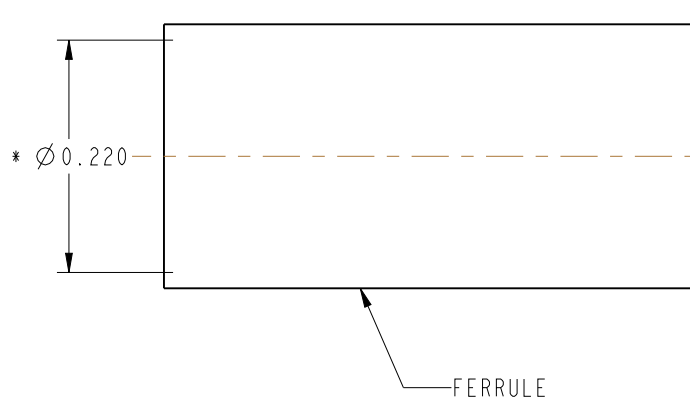

FERRULE

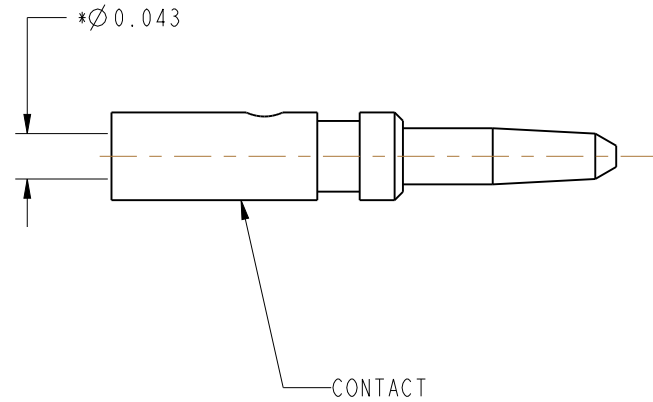

CONTACT

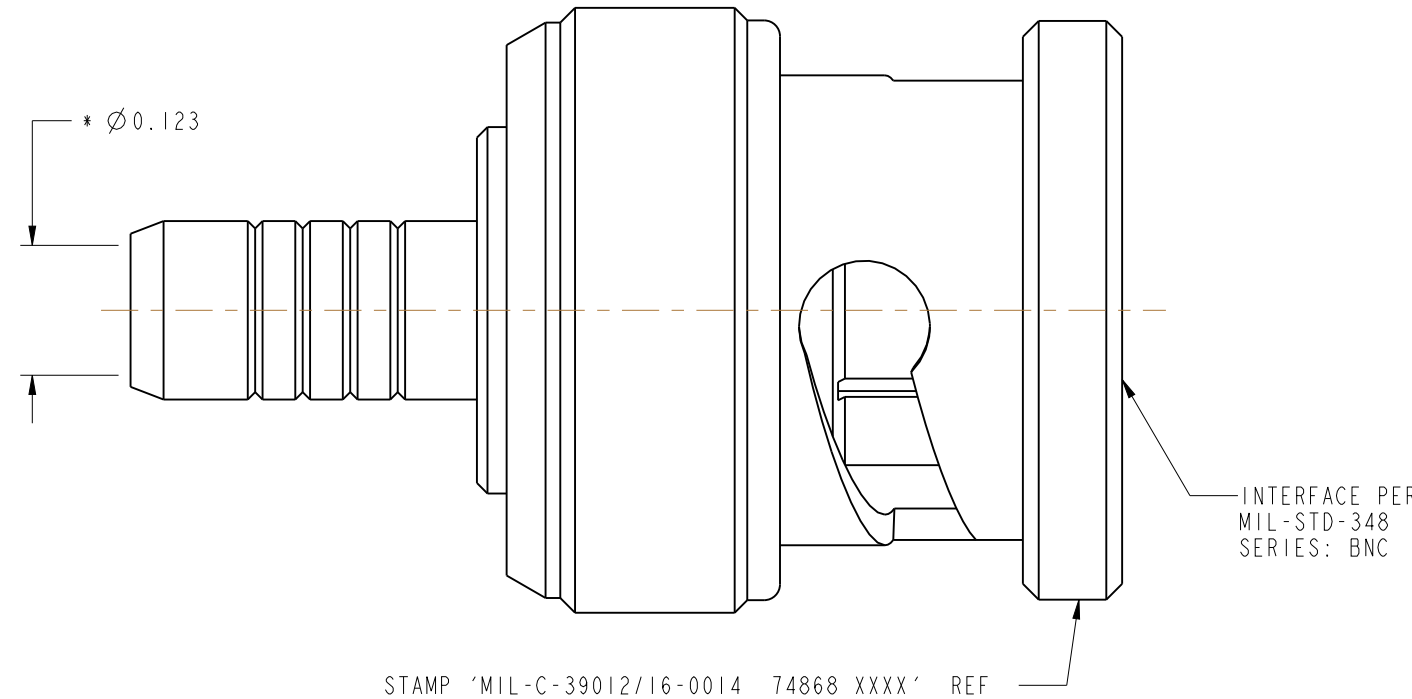

MIL-C-39012 INSPECTION

CUSTOMER OUTLINE DRAWING
 ALL OTHER SHEETS ARE FOR INTERNAL USE ONLY

THIS CONNECTOR IS COVERED BY U.S. PATENT 3,336,563

UNLESS OTHERWISE SPECIFIED, DIMENSIONS ARE IN INCHES AND TOLERANCES ARE: 2 PLACE DECIMAL 3 PLACE DECIMAL ANGLES $\pm .015$ (0,381 mm) $\pm .005$ (0,127 mm) $\pm 1^\circ$	MATERIAL	DRAWN	DATE	TITLE	Amphenol RF Danbury, CT, USA Tainan, Taiwan Shenzhen, China www.amphenolrf.com
	SEE NOTES	KARTHIK R	01-Jun-11	BNC PLUG	
NOTICE - These drawings, specifications, or other data (1) are, and remain the property of Amphenol Corp. (2) must be returned upon request; and (3) are confidential and not to be disclosed to any person other than those to whom they are given by Amphenol Corp. The furnishing of these drawings, specifications, or other data by Amphenol Corp., or to any other person to anyone for any purpose is not to be regarded by implication or otherwise in any manner licensing, granting rights or permitting such holder or any other person to manufacture, use or sell any product, process or design, patented or otherwise, that may in any way be related to or disclosed by said drawings, specifications, or other data.	REFERENCE	ENGINEER	DATE	MIL-CRIMP (CATEGORY C),	SCALE: 5.5:1 SHEET 2 OF 2
	MIL-C-39012/16-0014	KARTHIK R	01-Jun-11	FOR RG 55, 142 & 223 CABLE	
		APPROVED	DATE		
	K. CAPOZZI	1/14/13			
	CAD FILE	CODE ID	DWG SIZE	DRAWING NO.	REV
	Root Folder/BNC/31-4326	74868	B	31-4326	P

X-ON Electronics

Largest Supplier of Electrical and Electronic Components

Click to view similar products for [RF Connectors / Coaxial Connectors](#) category:

Click to view products by [Amphenol](#) manufacturer:

Other Similar products are found below :

[8915-1511-000](#) [89674-0827](#) [6001-7071-019](#) [6002-7051-003](#) [6002-7551-202](#) [6059674-1](#) [619550-1](#) [630059-000](#) [M39030/3-01N](#) [M3933/25-36N](#) [6500-7071-046](#) [6769](#) [CX050L2AQ](#) [7002-1542-011](#) [7004-1512-000](#) [7009-1511-004](#) [7010-1511-000](#) [7029-1511-060](#) [7101-1541-010](#) [7101-1571-002](#) [7105-1521-002](#) [7145-1521-002](#) [7203-1571-003](#) [7209-1511-011](#) [7210-1511-015](#) [7210-1511-019](#) [73137-5015](#) [73216-2241](#) [7325-1512-000](#) [73404-2300](#) [7405-1521-005](#) [7405-1521-802](#) [7406-1521-005](#) [8527](#) [8547](#) [FS11V](#) [8808-1511-001](#) [9049-9513-000](#) [9074-9513-000](#) [9101-9573-002](#) [910A205F](#) [9130-9573-002](#) [PL11SC-026](#) [PL375-33](#) [PL40-5](#) [PL71-9](#) [PL74C-221](#) [PL75MC-217](#) [PL803-7](#) [980-8666-005](#)