

NOTES:

1. MATERIALS AND FINISHES:
 BODY - BRASS, GOLD PLATING.
 CONTACT - BeCu, GOLD PLATING.
 INSULATOR - PTFE, NATURAL
2. ELECTRICAL:
 A. IMPEDANCE: 75 OHM
 B. FREQUENCY RANGE: DC - 4 GHz
 C. RETURN LOSS: -30 dB MIN AT 3 GHz
 D. DIELECTRIC WITHSTANDING VOLTAGE: 1000 VRMS, MIN.
 E. INSULATION RESISTANCE: 10,000 MEGOHMS MIN
3. MECHANICAL:
 A. DURABILITY: 500 CYCLES MIN.
 B. TEMPERATURE RANGE: -65° C TO +165° C
4. ENVIRONMENTAL:
 A. THERMAL SHOCK PER MIL-STD-202 METHOD 107
 TEST CONDITION B (EXCEPT HIGH TEMP @200°C)
 B. VIBRATION: MIL-STD-202 METHOD 204 TEST CONDITION B
 C. SHOCK: MIL-STD-202 METHOD 213 TEST CONDITION B
 D. CORROSION: MIL-STD-202 METHOD 101
 TEST CONDITION B 5% SALT SOLUTION
5. PACKAGING:
 A. QUANTITY: SINGLE PACK
 B. MARKING: BAG TO BE MARKED:
 "AMPHENOL RF, 34-1028 DATE CODE"

THIRD ANGLE PROJ.

REVISIONS

REV	DESCRIPTION	DATE	ECO	APPR
A	RELEASED TO MFG.	25-May-11	48270	TD
B	CHANGE THE BODY AND INSULATOR\RD-DM1101401R3	20-Oct-11	48820	SH

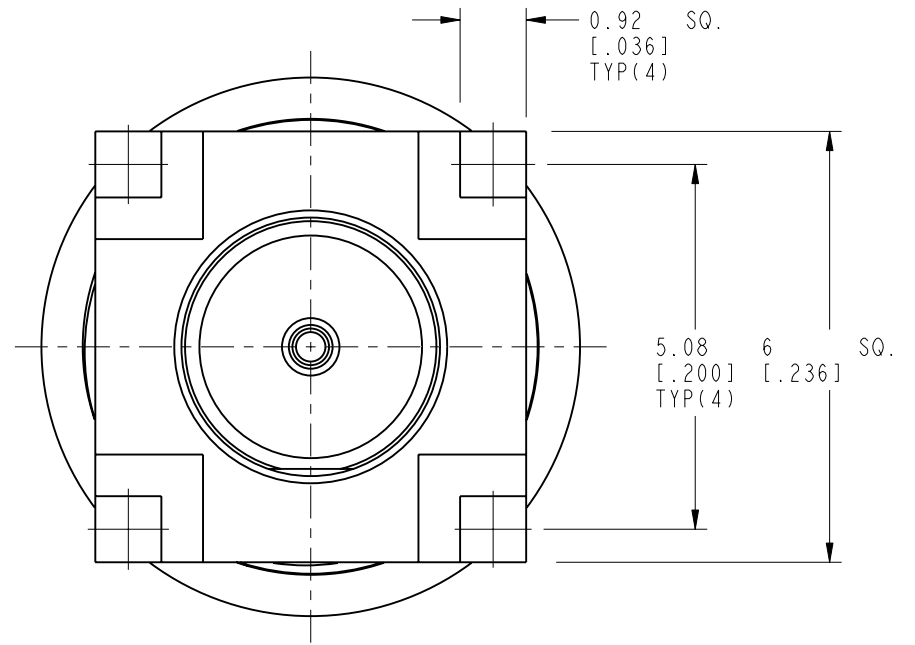
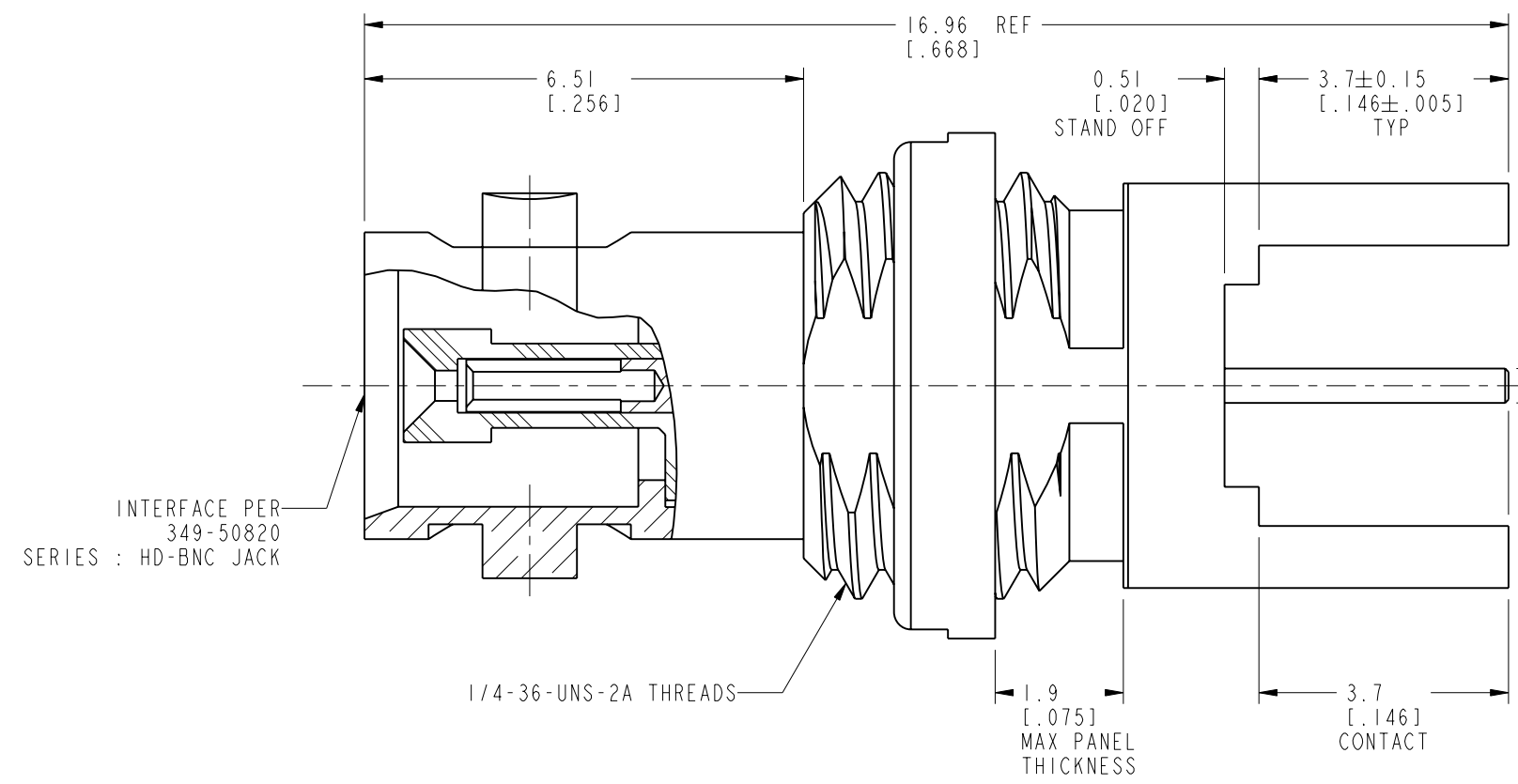
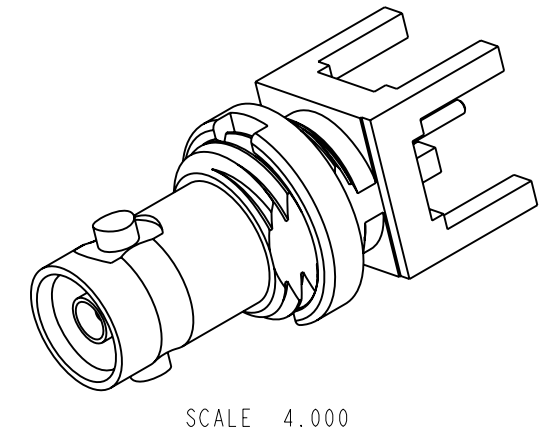
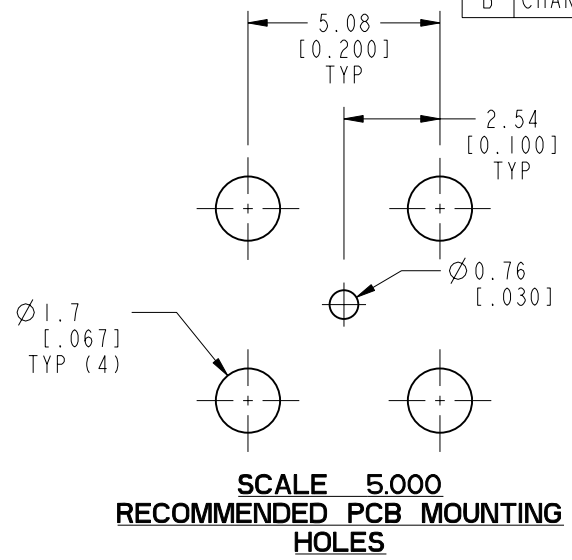
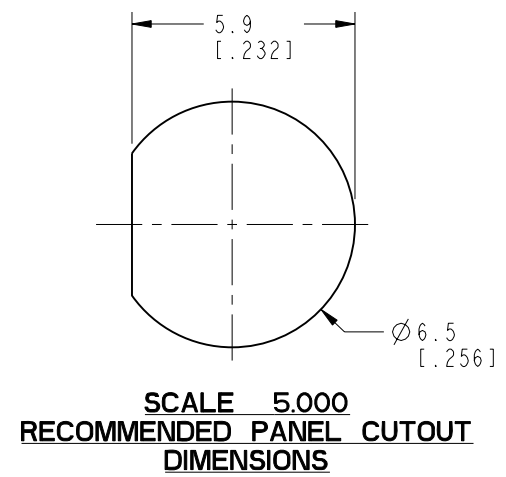

CUSTOMER OUTLINE DRAWING
 ALL OTHER SHEETS ARE FOR INTERNAL USE ONLY

UNLESS OTHERWISE SPECIFIED, DIMENSIONS ARE IN METRIC AND TOLERANCES ARE: <0.5mm ±0.05mm 0.5 - 6mm ±0.1mm 6 - 30mm ±0.2mm 30 - 120mm ±0.3mm ANGLES ±1°	MATERIAL	DRAWN	DATE	TITLE HD BNC STR JACK BHD PCB THRU HOLE RECEPTACLE	Amphenol RF Danbury CT USA, Tainan, Taiwan, Shenzhen, China www.amphenolrf.com
	SEE NOTES	R. MAO	20-Oct-11		
NOTICE - These drawings, specifications, or other data (1) are, and remain the property of Amphenol corp. (2) must be returned upon request; and (3) are confidential and not to be disclosed to any person other than those to whom they are given by Amphenol Corp. the furnishing of these drawings, specifications, or other data by Amphenol Corp., or to any other person for any purpose is not to be regarded by implication or otherwise in any manner licensing, granting rights to permitting such holder or any other person to manufacture, use or sell any product, process or design, patented or otherwise, that may in any way be related to or disclosed by said drawings, specifications, or other data.	REFERENCE	ENGINEER	DATE	SCALE: 9.5:1.0 SHEET 2 OF 4	DRAWING NO. 34-1028 ITEM NO. 34-1028 PART NO. 34-1028
	EAR # 3989	A. ARUN PRABU	19-Mar-10		
	CONFIGURATION LEVEL:	APPROVED	DATE		DWG SIZE
FINISH	S. HSIEH	20-Oct-11		B	B

THIRD ANGLE PROJ.

REVISIONS

REV	DESCRIPTION	DATE	ECO	APPR
A	RELEASED TO MFG.	25-May-11	48270	TD
B	CHANGE THE BODY AND INSULATOR\RD-DM11101401R3	20-Oct-11	48820	SH

RECOMMENDED PCB LAUNCH FOR OPTIMAL RF PERFORMANCE

VARIATIONS IN BOARD SUBSTRATE AND TRACE MAY REQUIRE DIFFERENT GEOMETRY

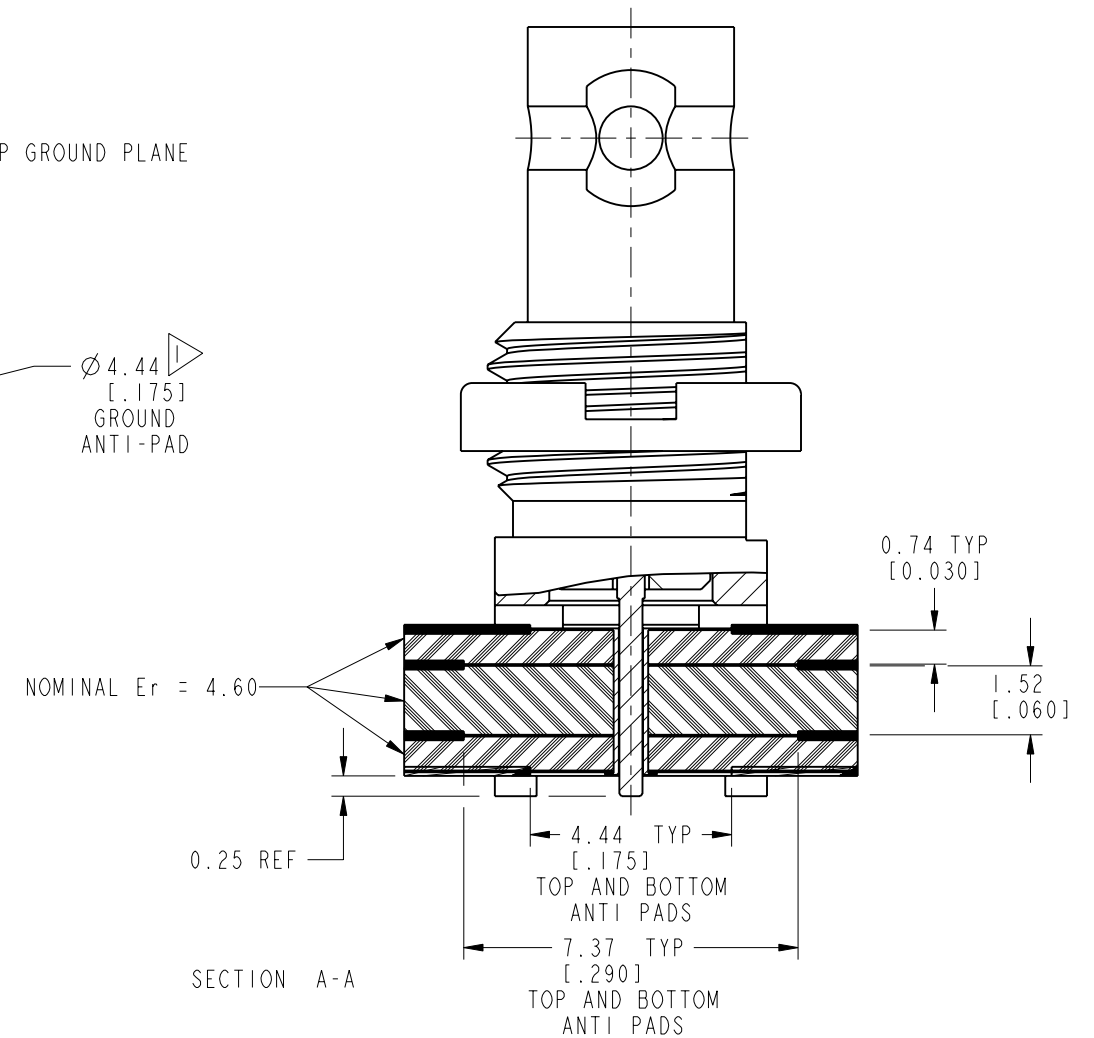
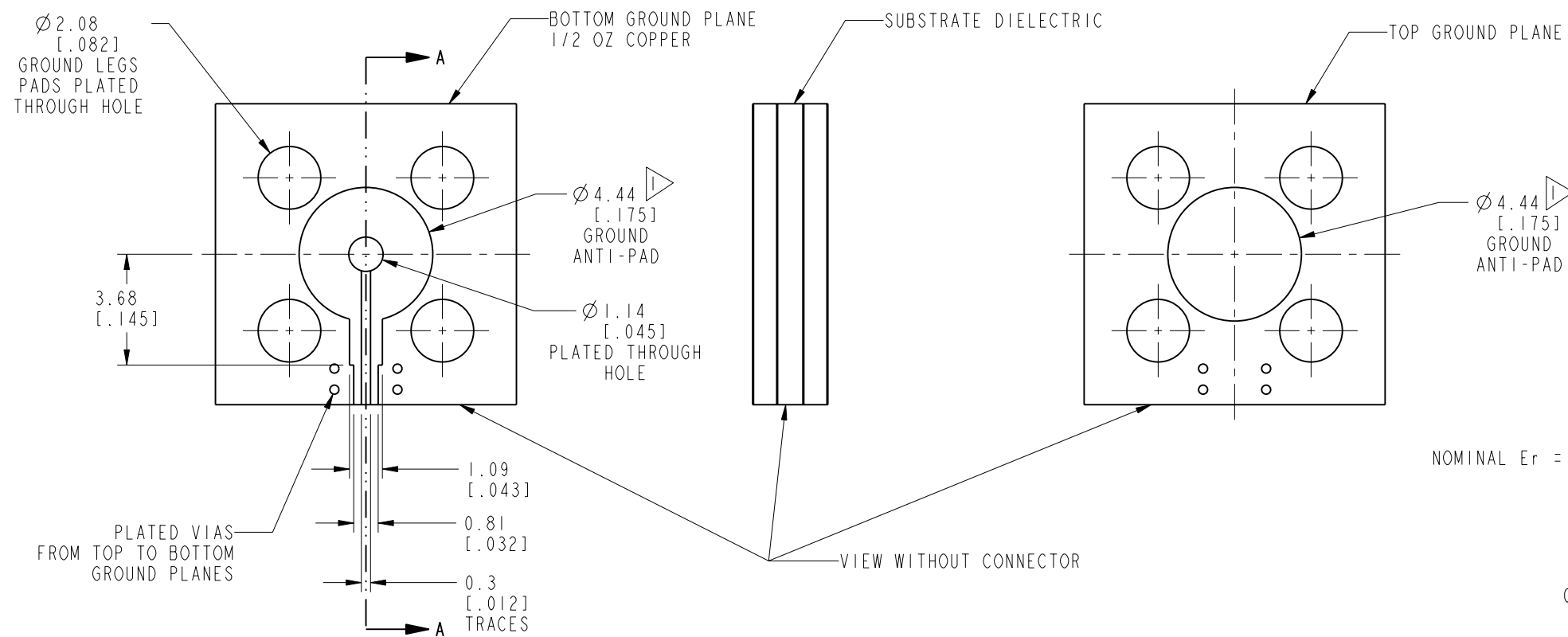

NOTES:

INTERNAL GROUND LAYERS SHALL HAVE ANTI PAD OD $\varnothing 7.37$ MM [.290 INCH] MIN.

CUSTOMER OUTLINE DRAWING

ALL OTHER SHEETS ARE FOR INTERNAL USE ONLY

<p>UNLESS OTHERWISE SPECIFIED, DIMENSIONS ARE IN METRIC AND TOLERANCES ARE: <0.5mm ±0.05mm 0.5 - 6mm ±0.1mm 6 - 30mm ±0.2mm 30 - 120mm ±0.3mm ANGLES ±1°</p> <p>NOTICE - These drawings, specifications, or other data (1) are, and remain the property of Amphenol corp. (2) must be returned upon request; and (3) are confidential and not to be disclosed to any person other than those to whom they are given by Amphenol Corp. the finishing of these drawings, specifications, or other data by Amphenol Corp., or to any other person to anyone for any purpose is not to be regarded by implication or otherwise in any manner licensing, granting rights to permitting such holder or any other person to manufacture, use or sell any product, process or design, patented or otherwise, that may in any way be related to or disclosed by said drawings, specifications, or other data.</p>	MATERIAL	DRAWN R. MAO	DATE 20-Oct-11	<p>TITLE HD BNC STR JACK BHD PCB THRU HOLE RECEPTACLE</p> <p>SCALE: 1.0:1.0 SHEET 3 OF 4</p> <p>DWG SIZE B REV B</p>	<p>Amphenol RF Danbury CT USA, Tainan, Taiwan, Shenzhen, China www.amphenolrf.com</p>
	REFERENCE EAR # 3989	ENGINEER A ARUN PRABU	DATE 19-Mar-10		
CONFIGURATION LEVEL:	APPROVED S. HSIEH	DATE 20-Oct-11		ITEM NO. 34-1028	
FINISH				PART NO. 34-1028	

THIRD ANGLE PROJ.

REVISIONS

REV	DESCRIPTION	DATE	ECO	APPR
A	RELEASED TO MFG.	25-May-11	48270	TD
B	CHANGE THE BODY AND INSULATOR\RD-DM11101401R3	20-Oct-11	48820	SH

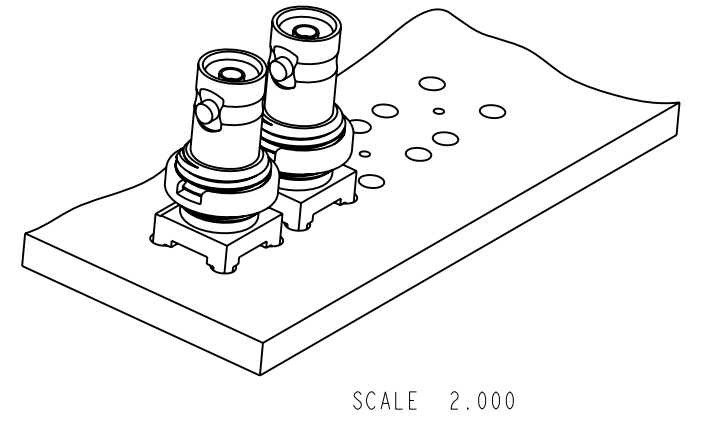
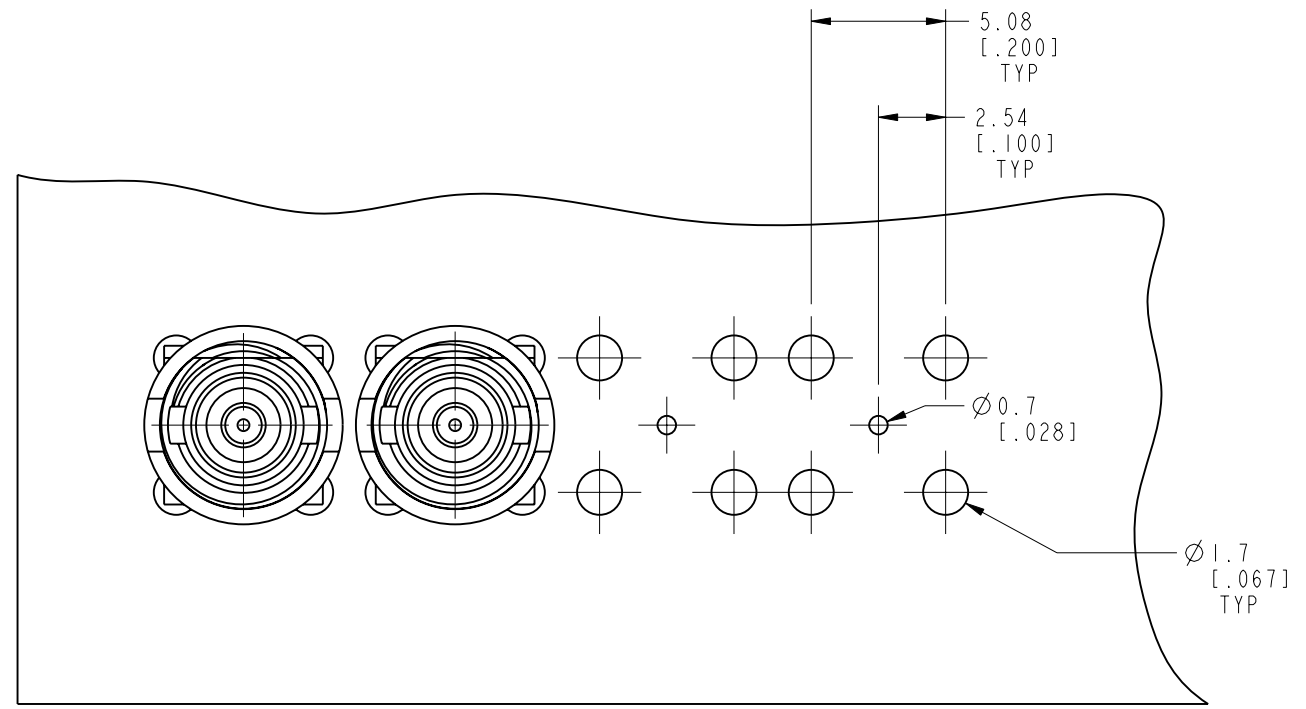

RECOMMENDED PCB MOUNTING HOLES

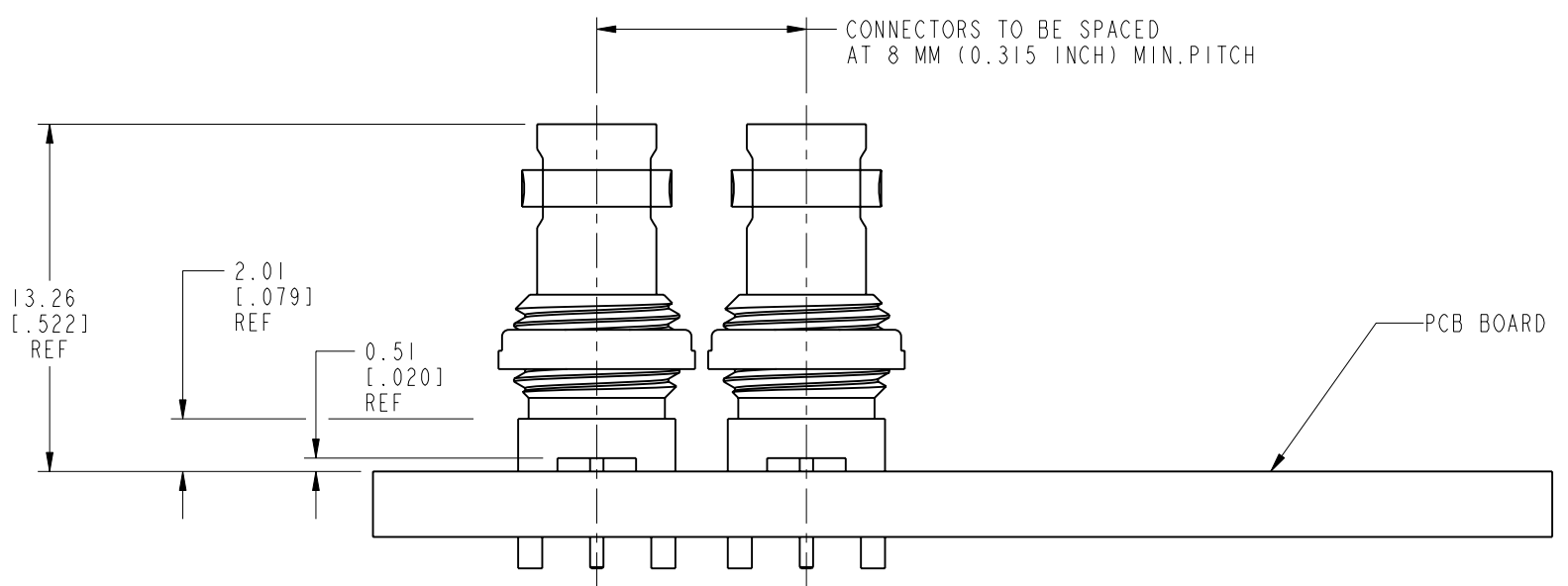

CUSTOMER OUTLINE DRAWING

ALL OTHER SHEETS ARE FOR INTERNAL USE ONLY

<p>UNLESS OTHERWISE SPECIFIED, DIMENSIONS ARE IN METRIC AND TOLERANCES ARE: <0.5mm ±0.05mm 0.5 - 6mm ±0.1mm 6 - 30mm ±0.2mm 30 - 120mm ±0.3mm ANGLES ±1°</p> <p>NOTICE - These drawings, specifications, or other data (1) are, and remain the property of Amphenol corp. (2) must be returned upon request; and (3) are confidential and not to be disclosed to any person other than those to whom they are given by Amphenol Corp. the finishing of these drawings, specifications, or other data by Amphenol Corp., or to any other person to anyone for any purpose is not to be regarded by implication or otherwise in any manner licensing, granting rights to permitting such holder or any other person to manufacture, use or sell any product, process or design, patented or otherwise, that may in any way be related to or disclosed by said drawings, specifications, or other data.</p>	MATERIAL	DRAWN R. MAO	DATE 20-Oct-11	<p>TITLE HD BNC STR JACK BHD PCB THRU HOLE RECEPTACLE</p> <p>SCALE: 12.0:1.0 SHEET 4 OF 4</p>	<p>Amphenol RF Danbury CT USA, Tainan, Taiwan, Shenzhen, China www.amphenolrf.com</p>
	REFERENCE EAR # 3989	ENGINEER A ARUN PRABU	DATE 19-Mar-10		
CONFIGURATION LEVEL:	APPROVED S. HSIEH	DATE 20-Oct-11		ITEM NO. 34-1028	
FINISH		CAD FILE		DWG SIZE B	REV B
					PART NO. 34-1028

X-ON Electronics

Largest Supplier of Electrical and Electronic Components

Click to view similar products for [RF Connectors / Coaxial Connectors](#) category:

Click to view products by [Amphenol](#) manufacturer:

Other Similar products are found below :

[8915-1511-000](#) [89674-0827](#) [6001-7071-019](#) [6002-7051-003](#) [6002-7551-202](#) [6059674-1](#) [619550-1](#) [630059-000](#) [M39030/3-01N](#) [M3933/25-36N](#) [6500-7071-046](#) [6769](#) [CX050L2AQ](#) [7002-1542-011](#) [7004-1512-000](#) [7009-1511-004](#) [7010-1511-000](#) [7029-1511-060](#) [7101-1541-010](#) [7101-1571-002](#) [7105-1521-002](#) [7145-1521-002](#) [7203-1571-003](#) [7209-1511-011](#) [7210-1511-015](#) [7210-1511-019](#) [73137-5015](#) [73216-2241](#) [7325-1512-000](#) [73404-2300](#) [7405-1521-005](#) [7405-1521-802](#) [7406-1521-005](#) [8527](#) [8547](#) [FS11V](#) [8808-1511-001](#) [9049-9513-000](#) [9074-9513-000](#) [9101-9573-002](#) [910A205F](#) [9130-9573-002](#) [PL11SC-026](#) [PL375-33](#) [PL40-5](#) [PL71-9](#) [PL74C-221](#) [PL75MC-217](#) [PL803-7](#) [980-8666-005](#)