

NOTES:

- MATERIALS AND FINISHES:
 BODY, CAP & NUT - BRASS, NICKEL PLATING
 REAR BODY - BRASS, GOLD PLATING
 CONTACT - BeCu, GOLD PLATING
 INSULATORS - PTFE, NATURAL
 INSULATOR - ULTEM 1000, NATURAL
- ELECTRICAL:
 A. IMPEDANCE: 75 OHMS
 B. FREQUENCY RANGE: DC - 18 GHz
 C. RETURN LOSS: 25 dB MIN @ DC - 6 GHz
 10 dB MIN @ 6 - 12 GHz
 D. DIELECTRIC WITHSTANDING VOLTAGE: 1000 VRMS, MIN.
 E. INSULATION RESISTANCE: 10,000 MEGAOHMS MIN
- MECHANICAL:
 A. DURABILITY: 500 CYCLES MIN.
- PACKAGING:
 A. QUANTITY: SINGLE PACK
 B. MARKING: BAG TO BE MARKED
 "AMPHENOL RF, 34-1030-12G & DATE CODE
 FREQUENCY RANGE: DC - 18 GHz"

THIRD ANGLE PROJ.

REVISIONS

REV	DESCRIPTION	DATE	ECN	APPR
A	RELEASE TO MFG.	03-Mar-16	51040	MJD
B	ADJUST THE BODY & HOUSING WALL THICKNESS RD-DMI6042901S2	06-May-16	--	HHE
C	NO CHANGE TO THIS SHEET	07-Jan-19	10141	SH
D	"Ø1.55" WAS "Ø1.70"	02-Jul-19	12062	SH

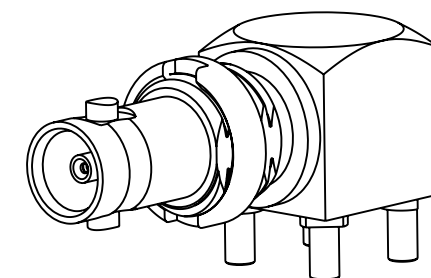

SCALE 3.000

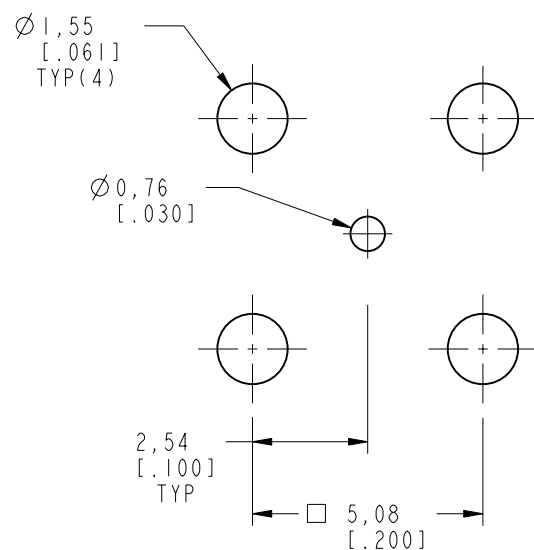
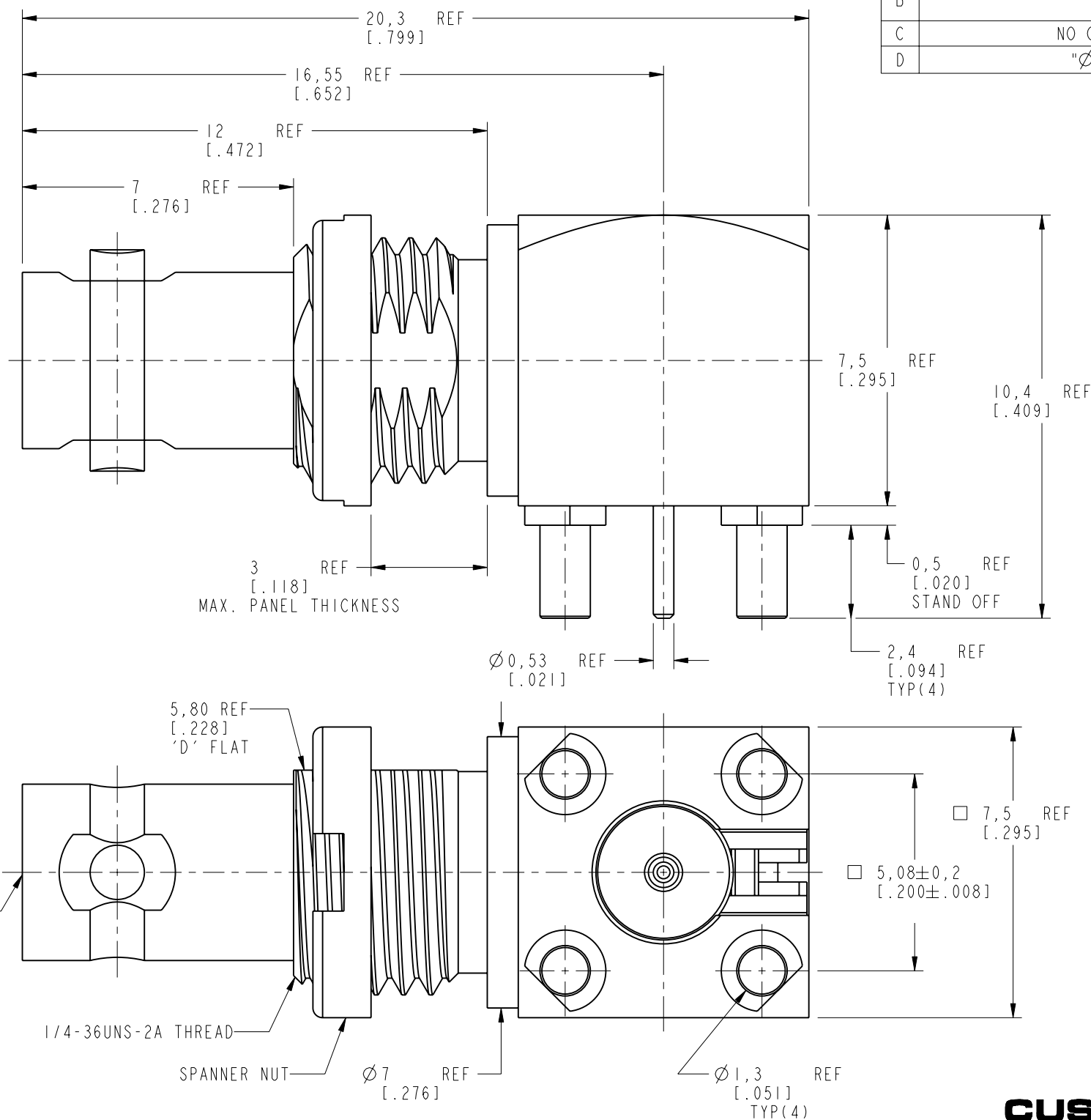

RECOMMENDED PCB LAYOUT

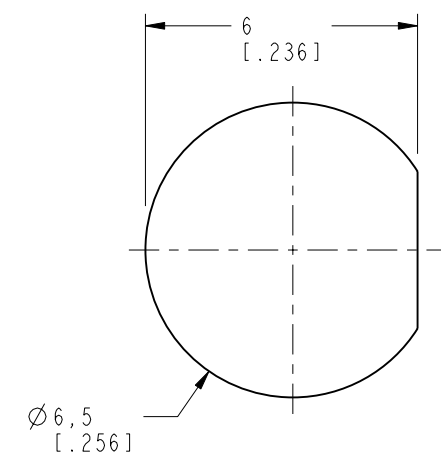

RECOMMENDED MOUNTING HOLE DIMENSIONS

CUSTOMER OUTLINE DRAWING

ALL OTHER SHEETS ARE FOR INTERNAL USE ONLY

UNLESS OTHERWISE SPECIFIED, DIMENSIONS ARE IN METRIC AND TOLERANCES ARE: <0.5mm ±0.05mm 0.5 - 6mm ±0.1mm 6 - 30mm ±0.2mm 30 - 120mm ±0.3mm ANGLES ±1°	MATERIAL	DRAWN	DATE	TITLE HD BNC RA BHD JACK PCB MOUNT		Amphenol RF www.amphenolrf.com	
	SEE NOTES	M. ZHANG	02-Jul-19				
NOTICE - These drawings, specifications, or other data (1) are, and remain the property of Amphenol corp. (2) must be returned upon request; and (3) are confidential and not to be disclosed to any person other than those to whom they are given by Amphenol Corp. the furnishing of these drawings, specifications, or other data by Amphenol Corp., or to any other person to anyone for any purpose is not to be regarded by implication or otherwise in any manner licensing, granting rights to permitting such holder or any other person to manufacture, use or sell any product, process or design, patented or otherwise, that may in any way be related to or disclosed by said drawings, specifications, or other data.	REFERENCE	ENGINEER	DATE	SCALE: 7.0:1.0 SHEET 2 OF 6		DRAWING NO. 34-1030-12G ITEM NO. 34-1030-12G PART NO. 34-1030-12G	
	EAR# 4028	KARTHIK R	19-Feb-16				
	REF:	APPROVED	S. HSIEH	DATE	DWG SIZE B	REV D	
	CONFIGURATION LEVEL: In Work	CAD FILE		02-Jul-19			
FINISH							

CONFIGURATION-O

REV	DESCRIPTION	DATE	ECN	APPR
A	RELEASE TO MFG.	03-Mar-16	51040	MJD
C	NO CHANGE TO THIS SHEET	07-Jan-19	10141	SH
D	NO CHANGE TO THIS SHEET	02-Jul-19	12062	SH

RECOMMENDED PCB LAUNCH FOR OPTIMAL RF PERFORMANCE

VARIATIONS IN BOARD MATERIAL AND TRACE MAY REQUIRE DIFFERENT GEOMETRY
PLEASE CONTACT AMPHENOL RF FOR LAUNCH OPTIMIZATION

BOTTOM LAYER

TOP LAYER

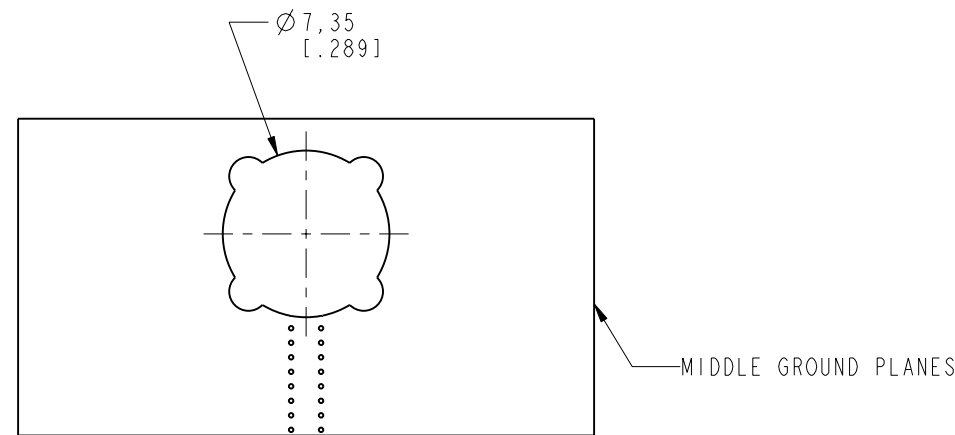
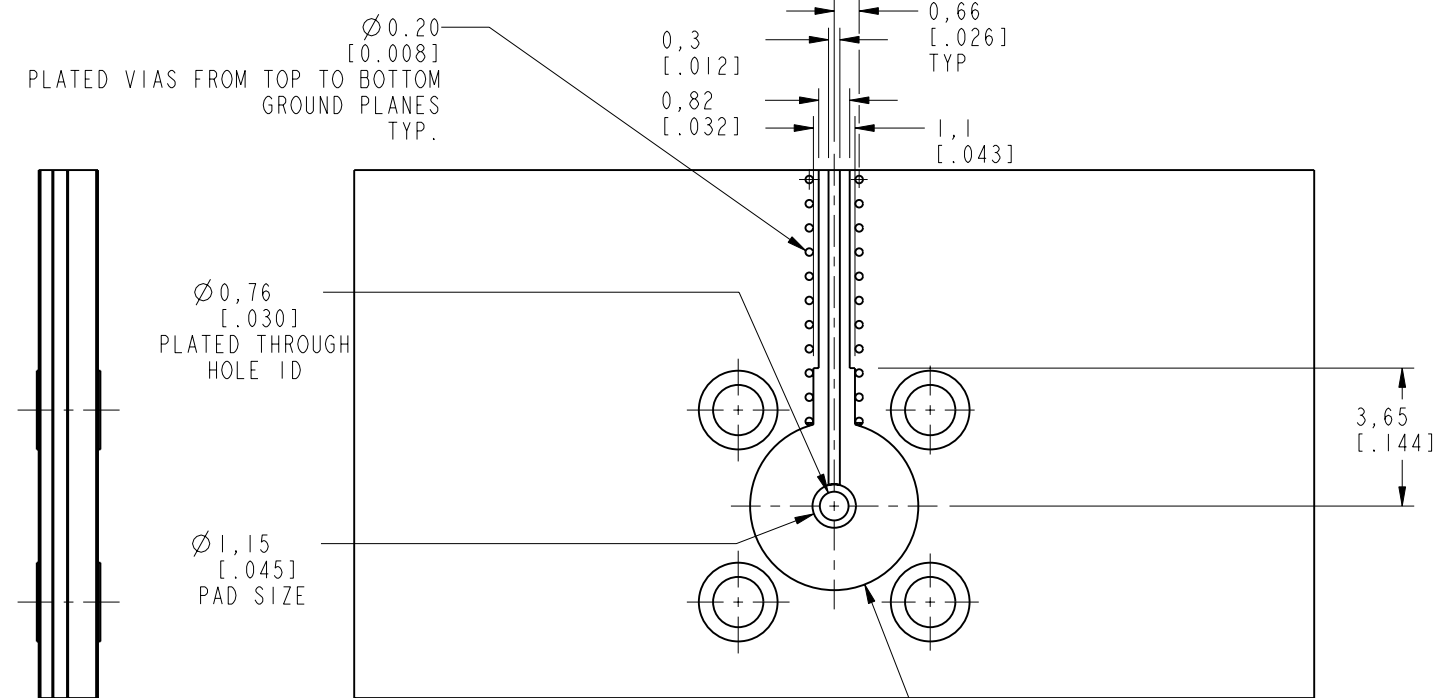
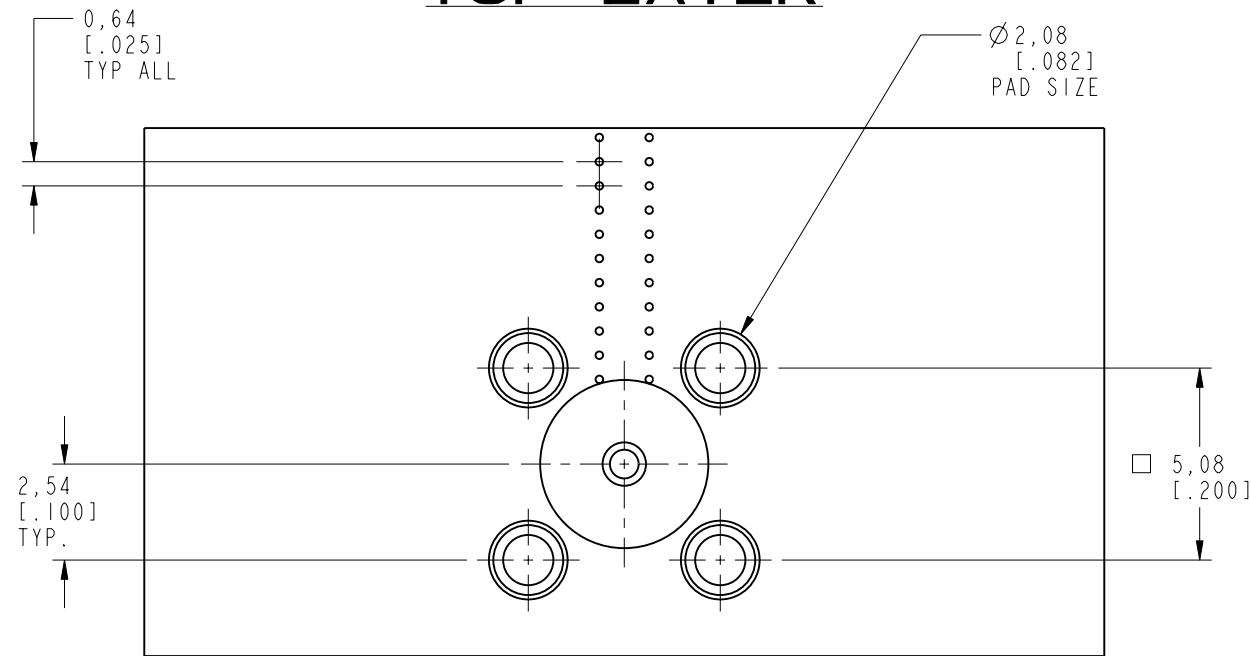

SCALE 3.000

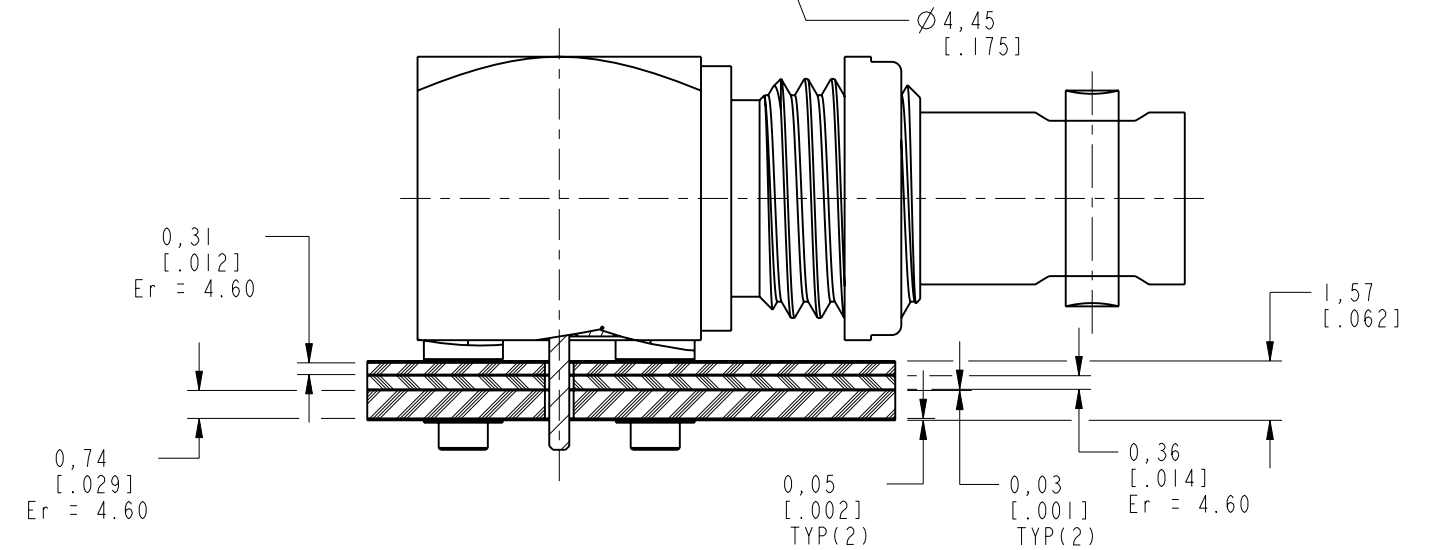

UNLESS OTHERWISE SPECIFIED, DIMENSIONS ARE IN METRIC AND TOLERANCES ARE:
 <0.5mm ±0.05mm 0.5 - 6mm ±0.1mm 6 - 30mm ±0.2mm 30 - 120mm ±0.3mm ANGLES ±1°

MATERIAL	DRAWN M. ZHANG	DATE 02-Jul-19
REFERENCE EAR# 4028	ENGINEER KARTHIK R	DATE 19-Feb-16
REF: CONFIGURATION LEVEL: In Work	APPROVED S. HSIEH	DATE 02-Jul-19
FINISH	CAD FILE	

TITLE HD BNC RA BHD JACK PCB MOUNT
SCALE: 5.0:1.0 SHEET 3 OF 6
DWG SIZE B
REV D

Amphenol RF	
www.amphenolrf.com	
DRAWING NO.	34-1030-12G
ITEM NO.	34-1030-12G
PART NO.	34-1030-12G

NOTICE - These drawings, specifications, or other data (1) are, and remain the property of Amphenol corp. (2) must be returned upon request; and (3) are confidential and not to be disclosed to any person other than those to whom they are given by Amphenol Corp. the furnishing of these drawings, specifications, or other data by Amphenol Corp., or to any other person to anyone for any purpose is not to be regarded by implication or otherwise in any manner licensing, granting rights to permitting such holder or any other person to manufacture, use or sell any product, process or design, patented or otherwise, that may in any way be related to or disclosed by said drawings, specifications, or other data.

REV	DESCRIPTION	DATE	ECN	APPR
A	RELEASE TO MFG.	03-Mar-16	51040	MJD
B	ADJUST THE BODY & HOUSING WALL THICKNESS \\RD-DMI6042901S2	06-May-16	--	HHE
C	NO CHANGE TO THIS SHEET	07-Jan-19	10141	SH
D	NO CHANGE TO THIS SHEET	02-Jul-19	12062	SH

CONFIGURATION-1

RECOMMENDED PCB LAUNCH FOR OPTIMAL RF PERFORMANCE

VARIATIONS IN BOARD MATERIAL AND TRACE MAY REQUIRE DIFFERENT GEOMETRY
PLEASE CONTACT AMPHENOL RF FOR LAUNCH OPTIMIZATION

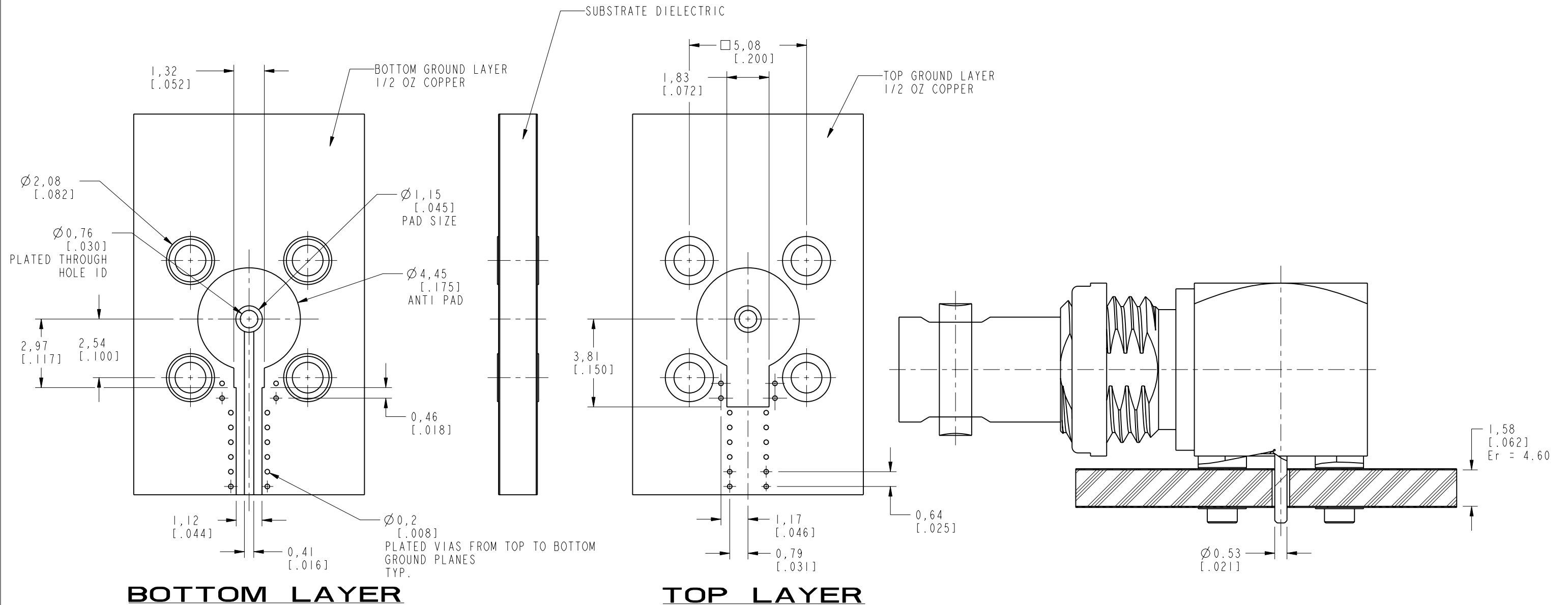

UNLESS OTHERWISE SPECIFIED, DIMENSIONS ARE IN METRIC AND TOLERANCES ARE:
 <0.5mm ±0.05mm 0.5 - 6mm ±0.1mm 6 - 30mm ±0.2mm 30 - 120mm ±0.3mm ANGLES ±1°

NOTICE - These drawings, specifications, or other data (1) are, and remain the property of Amphenol corp. (2) must be returned upon request; and (3) are confidential and not to be disclosed to any person other than those to whom they are given by Amphenol Corp. the furnishing of these drawings, specifications, or other data by Amphenol Corp., or to any other person to anyone for any purpose is not to be regarded by implication or otherwise in any manner licensing, granting rights to permitting such holder or any other person to manufacture, use or sell any product, process or design, patented or otherwise, that may in any way be related to or disclosed by said drawings, specifications, or other data.

MATERIAL	
REFERENCE	
EAR# 4028	
REF:	
CONFIGURATION LEVEL: In Work	
FINISH	

DRAWN	M. ZHANG	DATE	02-Jul-19
ENGINEER	KARTHIK R	DATE	19-Feb-16
APPROVED	S. HSIEH	DATE	02-Jul-19
CAD FILE			

TITLE	
HD BNC RA BHD JACK PCB MOUNT	
SCALE: 6.0:1.0	SHEET 4 OF 6
DWG SIZE	REV
B	D

Amphenol RF	
www.amphenolrf.com	
DRAWING NO.	34-1030-12G
ITEM NO.	34-1030-12G
PART NO.	34-1030-12G

REV	DESCRIPTION	DATE	ECN	APPR
A	RELEASE TO MFG.	03-Mar-16	51040	MJD
B	ADJUST THE BODY & HOUSING WALL THICKNESS ARD-DMI6042901S2	06-May-16	--	HHE
C	NO CHANGE TO THIS SHEET	07-Jan-19	10141	SH
D	NO CHANGE TO THIS SHEET	02-Jul-19	12062	SH

CONFIGURATION-2

RECOMMENDED PCB LAUNCH FOR OPTIMAL RF PERFORMANCE

VARIATIONS IN BOARD MATERIAL AND TRACE MAY REQUIRE DIFFERENT GEOMETRY
PLEASE CONTACT AMPHENOL RF FOR LAUNCH OPTIMIZATION

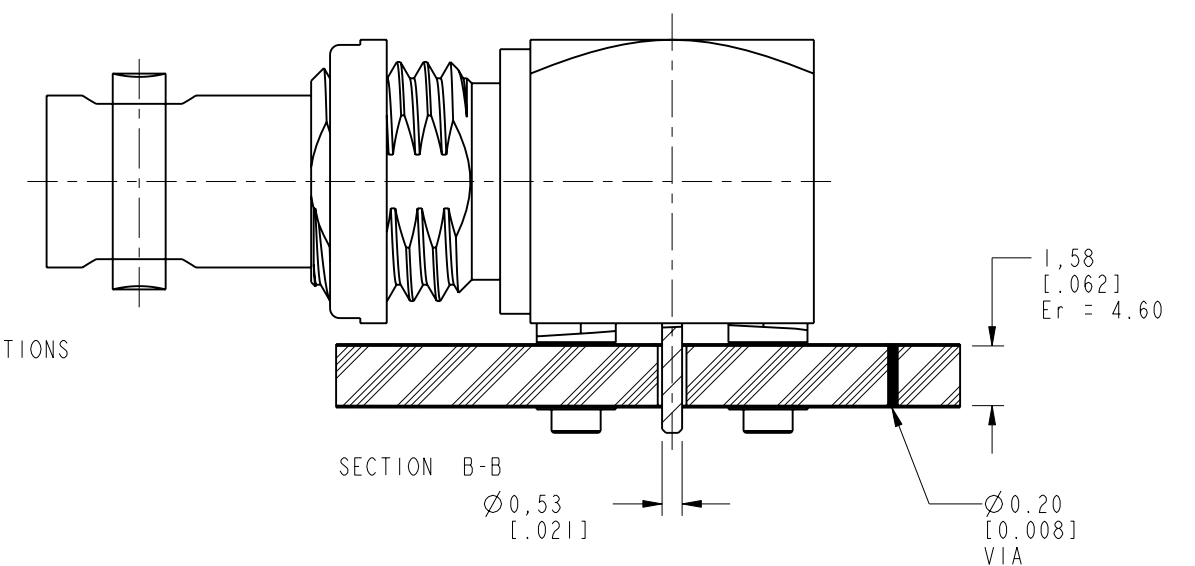
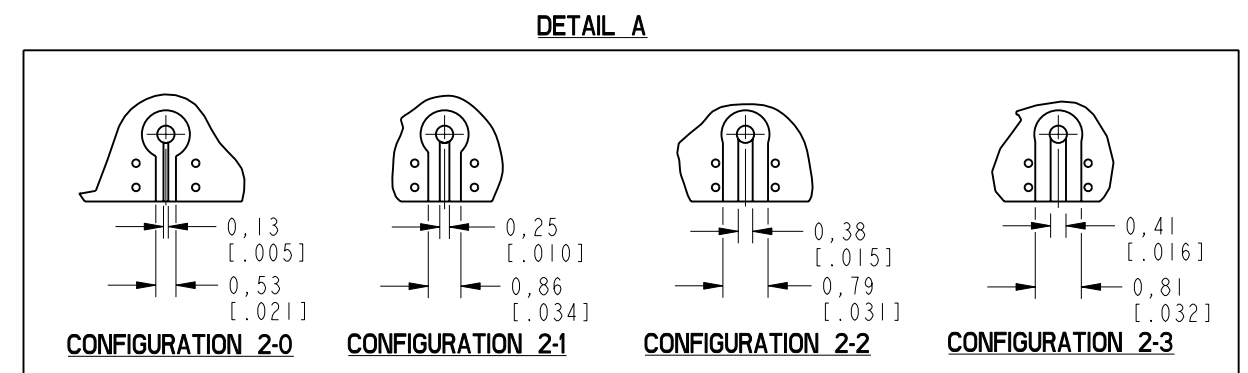
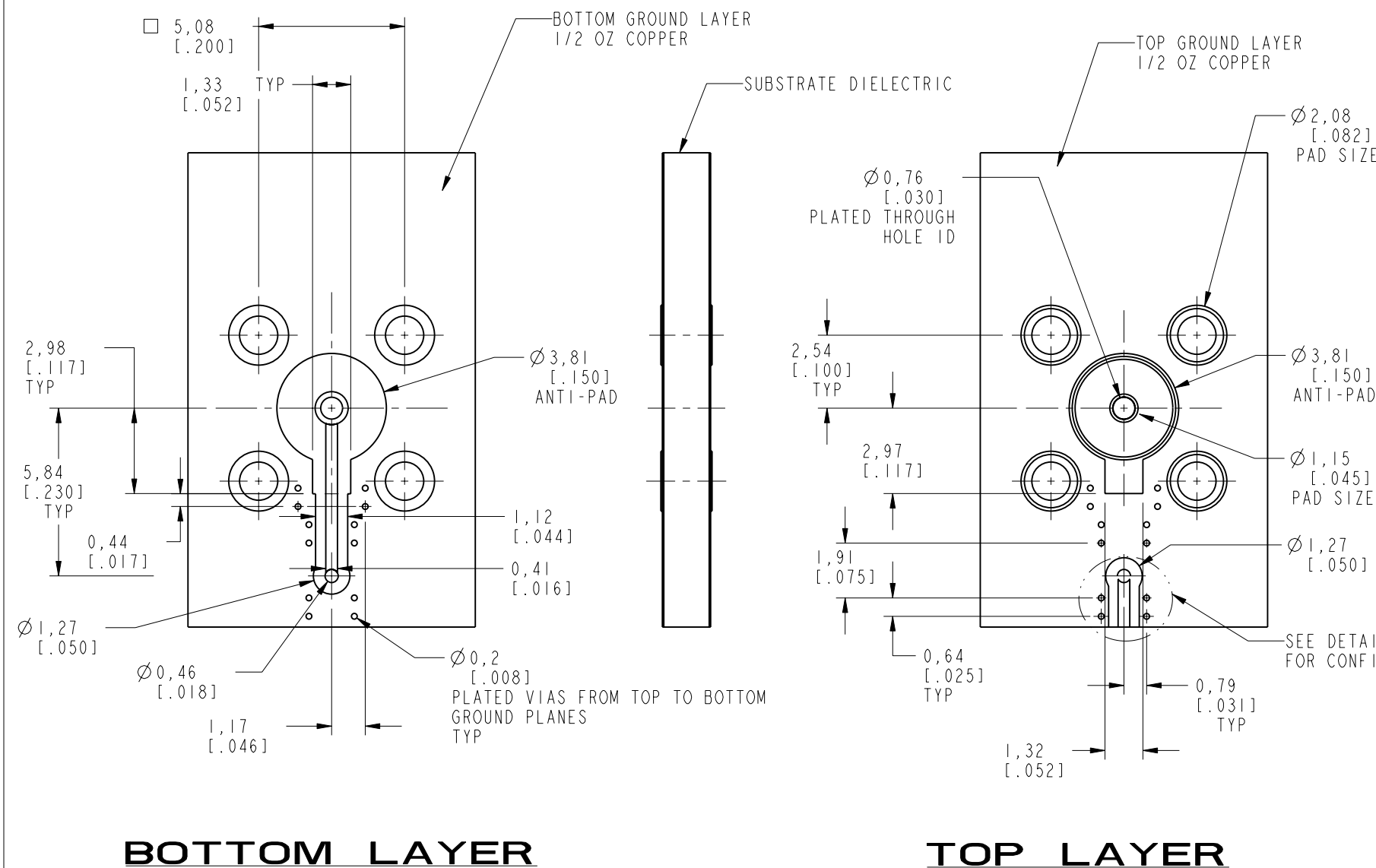

UNLESS OTHERWISE SPECIFIED, DIMENSIONS ARE IN METRIC AND TOLERANCES ARE:
 <0.5mm ±0.05mm 0.5 - 6mm ±0.1mm 6 - 30mm ±0.2mm 30 - 120mm ±0.3mm ANGLES ±1°

NOTICE - These drawings, specifications, or other data (1) are, and remain the property of Amphenol corp. (2) must be returned upon request; and (3) are confidential and not to be disclosed to any person other than those to whom they are given by Amphenol Corp. the furnishing of these drawings, specifications, or other data by Amphenol Corp., or to any other person to anyone for any purpose is not to be regarded by implication or otherwise in any manner licensing, granting rights to permitting such holder or any other person to manufacture, use or sell any product, process or design, patented or otherwise, that may in any way be related to or disclosed by said drawings, specifications, or other data.

MATERIAL	DRAWN	DATE
REFERENCE	M. ZHANG	02-Jul-19
EAR# 4028	ENGINEER	DATE
REF:	KARTHIK R	19-Feb-16
CONFIGURATION LEVEL: In Work	APPROVED	DATE
FINISH	S.HSIEH	02-Jul-19
	CAD FILE	

TITLE	SCALE: 5.0:1.0	SHEET 5 OF 6
HD BNC RA BHD JACK PCB MOUNT	DWG SIZE	REV
	B	D

Amphenol RF	
www.amphenolrf.com	
DRAWING NO.	34-1030-12G
ITEM NO.	34-1030-12G
PART NO.	34-1030-12G

THIRD ANGLE PROJ.

REVISIONS

REV	DESCRIPTION	DATE	ECN	APPR
A	RELEASE TO MFG.	03-Mar-16	51040	MJD
B	ADJUST THE BODY & HOUSING WALL THICKNESS \\RD-DMI6042901S2	06-May-16	--	HHE
C	NO CHANGE TO THIS SHEET	07-Jan-19	10141	SH
D	Ø1.55 WAS Ø1.70 & Ø0.76 WAS Ø0.70	02-Jul-19	12062	SH

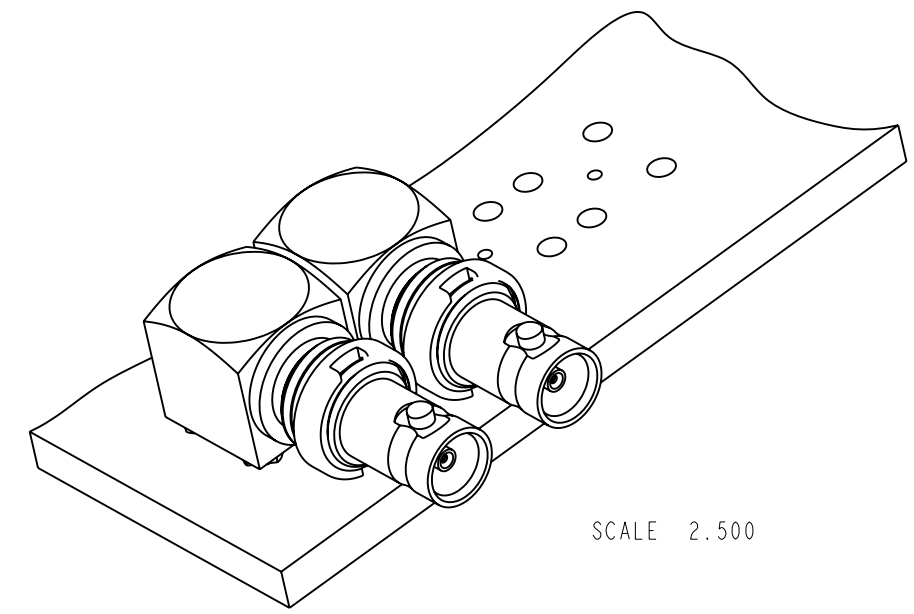
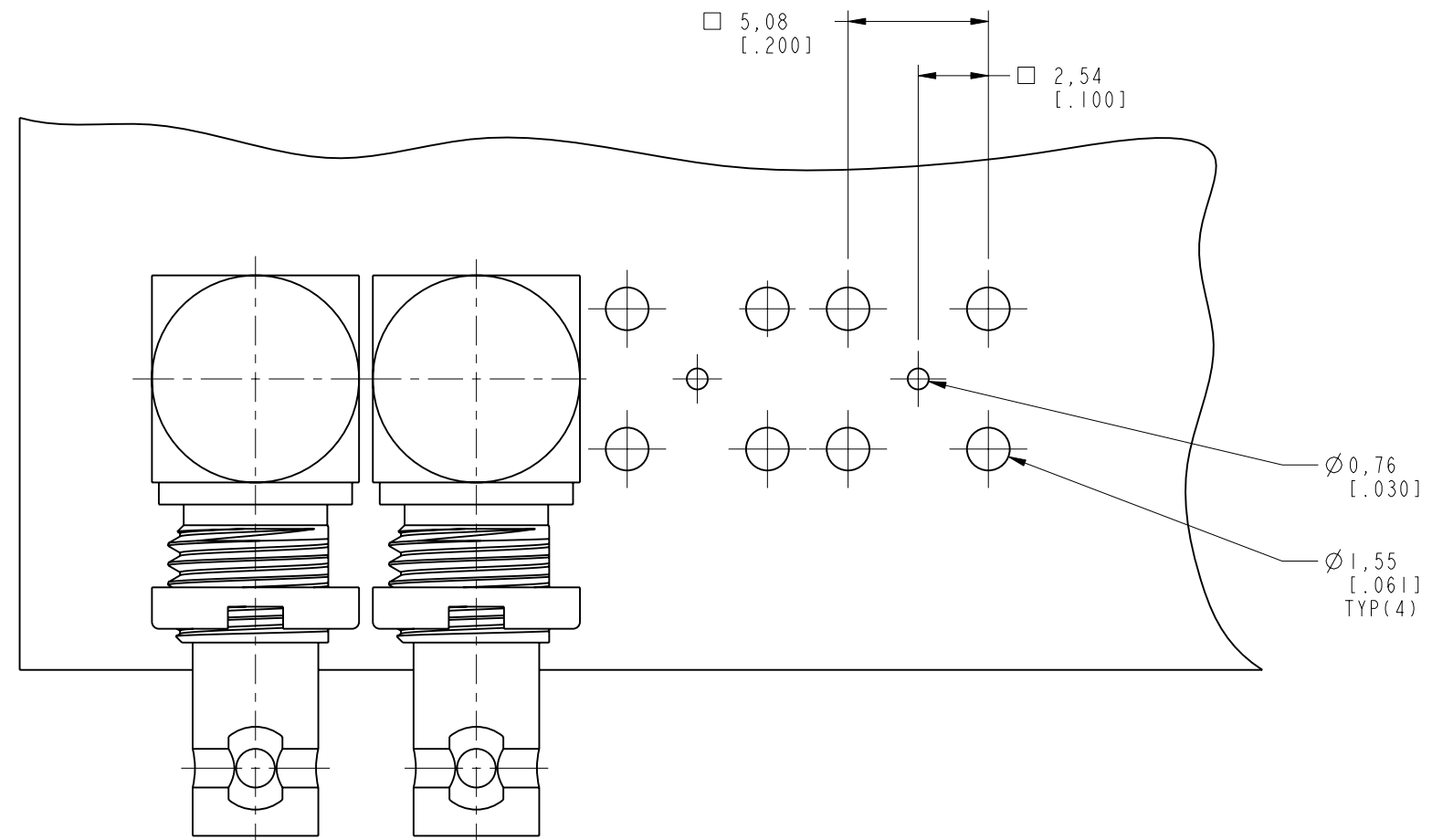

CONNECTORS TO BE SPACED AT 8.00 MM [0.315] MIN. PITCH.

RECOMMENDED PCB MOUNTING HOLES

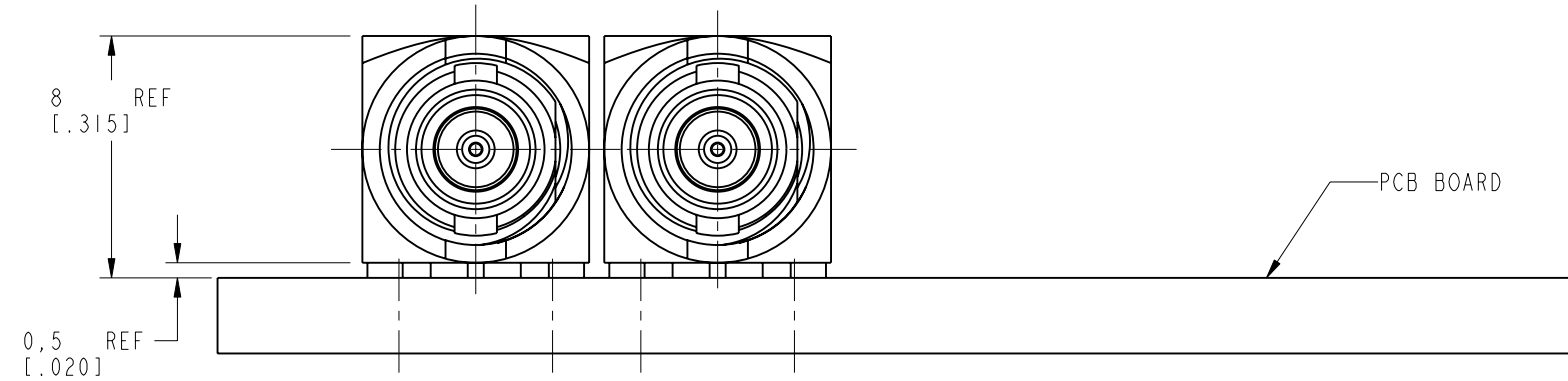

CUSTOMER OUTLINE DRAWING
ALL OTHER SHEETS ARE FOR INTERNAL USE ONLY

<p>UNLESS OTHERWISE SPECIFIED, DIMENSIONS ARE IN METRIC AND TOLERANCES ARE: <0.5mm ±0.05mm 0.5 - 6mm ±0.1mm 6 - 30mm ±0.2mm 30 - 120mm ±0.3mm ANGLES ±1°</p> <p>NOTICE - These drawings, specifications, or other data (1) are, and remain the property of Amphenol corp. (2) must be returned upon request; and (3) are confidential and not to be disclosed to any person other than those to whom they are given by Amphenol Corp. the furnishing of these drawings, specifications, or other data by Amphenol Corp., or to any other person to anyone for any purpose is not to be regarded by implication or otherwise in any manner licensing, granting rights to permitting such holder or any other person to manufacture, use or sell any product, process or design, patented or otherwise, that may in any way be related to or disclosed by said drawings, specifications, or other data.</p>	<p>MATERIAL</p>	<p>DRAWN M. ZHANG</p>	<p>DATE 02-Jul-19</p>	<p>TITLE HD BNC RA BHD JACK PCB MOUNT</p>	<p>Amphenol RF www.amphenolrf.com</p>
	<p>REFERENCE EAR# 4028</p>	<p>ENGINEER KARTHIK R</p>	<p>DATE 19-Feb-16</p>		
<p>REF: CONFIGURATION LEVEL: In Work</p>	<p>FINISH</p>	<p>APPROVED S.HSIEH</p>	<p>DATE 02-Jul-19</p>	<p>SCALE: 4.0:1.0 SHEET 6 OF 6</p>	<p>ITEM NO. 34-1030-12G</p>
		<p>CAD FILE</p>		<p>DWG SIZE B</p>	<p>REV D</p>
					<p>PART NO. 34-1030-12G</p>

X-ON Electronics

Largest Supplier of Electrical and Electronic Components

Click to view similar products for [RF Connectors / Coaxial Connectors](#) category:

Click to view products by [Amphenol](#) manufacturer:

Other Similar products are found below :

[8915-1511-000](#) [89674-0827](#) [6001-7071-019](#) [6002-7051-003](#) [6002-7551-202](#) [6059674-1](#) [619550-1](#) [630059-000](#) [M39030/3-01N](#) [M3933/25-36N](#) [6500-7071-046](#) [6769](#) [CX050L2AQ](#) [7002-1542-011](#) [7004-1512-000](#) [7009-1511-004](#) [7010-1511-000](#) [7029-1511-060](#) [7101-1541-010](#) [7101-1571-002](#) [7105-1521-002](#) [7145-1521-002](#) [7203-1571-003](#) [7209-1511-011](#) [7210-1511-015](#) [7210-1511-019](#) [73137-5015](#) [73216-2241](#) [7325-1512-000](#) [73404-2300](#) [7405-1521-005](#) [7405-1521-802](#) [7406-1521-005](#) [8527](#) [8547](#) [FS11V](#) [8808-1511-001](#) [9049-9513-000](#) [9074-9513-000](#) [9101-9573-002](#) [910A205F](#) [9130-9573-002](#) [PL11SC-026](#) [PL375-33](#) [PL40-5](#) [PL71-9](#) [PL74C-221](#) [PL75MC-217](#) [PL803-7](#) [980-8666-005](#)