

REVISIONS			
REV	ECN, ERN NO.	DATE	APPRD.
A	PRODUCT DRAWING	DEC01/05	K.L.

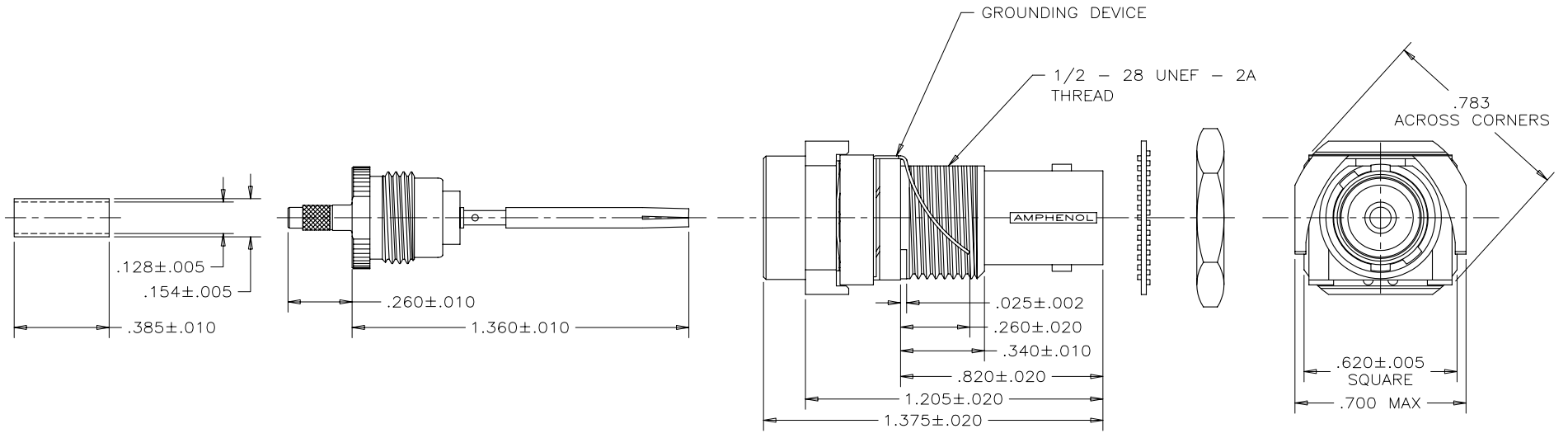

- MECHANICAL:** ALL MATERIALS ARE RoHS COMPLIANT
- THREADED HOUSING:** THERMOPLASTIC (COMPLIES WITH UL FLAMMABILITY REQUIREMENT OF 94V-0 PER UL-STD-94)
- GROUNDING DEVICE:** COPPER ALLOY, NICKEL PLATED
- METAL BODY:** HIGH STRENGTH ZINC DIECAST (NICKEL PLATED)
- CENTER CONTACT:** PHOSPHOR BRONZE, 30 MICROINCH, GOLD PLATED
- MOUNTING NUT:** BRASS, NICKEL PLATED

RECOMMENDED CABLE (RG-179)
STRIPPING DIM'S
CABLE IMPEDANCE: 75 OHM

RECOMMENDED PANEL CUTOUT

CRIMP WITH AMPHENOL TOOL 227-944 (M22520/5-01)
 AND DIE SET 227-1221-03 CAVITY 'A' (M22520/5-03)

ELECTRICAL SPECIFICATION:

AMPHENOL PART NO.	456E-218	456E-218S	456E-218SL*
CAPACITANCE	10000 pF ± 15%	10000 pF ± 15%	
DIELECTRIC WITHSTANDING VOLTAGE	1000 VDC	1050/700 VDC BREAK BY SPARK GAP DEVICE	
	500 V RMS		
WORKING VOLTAGE	200 VDC	200 VDC	
IMPEDANCE	75 OHM NOMINAL	75 OHM NOMINAL	
OPERATING TEMPERATURE	-20°C TO +85°C	-20°C TO +85°C	

* SEE SHEET 2 FOR PART NO. 456E-218SL.

DRAWN	S.BUENAVIDES	DATE	DEC01/05
CHECKED	K.LAMBIE	DATE	DEC02/05
DESIGNED			
APPROVED			
INDUSTRIAL ENG. APPRD.			
ENGINEERING RELEASE NO.			
REF.			
DIMENSIONS ARE IN	NO.	CODE IDENT.	
INCHES		03554	

Amphenol Canada Corp.		
TITLE 456E SERIES B.N.C. REAR MOUNT CAPACITIVELY DECOUPLED CONNECTOR, 10,000 pF, 75 OHM, CRIMP, RoHS COMPLIANT		
DWG	DRAWING NO.	REV.
C	P-456E-218XX	A
SCALE	3/1	WT. SURF. SHEET 1 OF 3

THIS DOCUMENT CONTAINS PROPRIETARY INFORMATION AND SUCH INFORMATION MAY NOT BE DISCLOSED TO OTHERS FOR ANY PURPOSE OR USED FOR MANUFACTURING PURPOSES WITHOUT WRITTEN PERMISSION FROM AMPHENOL CANADA CORP.

REVISIONS			
REV	ECN, ERN NO.	DATE	APPRD.
A	PRODUCT DRAWING	DEC01/05	K.L.

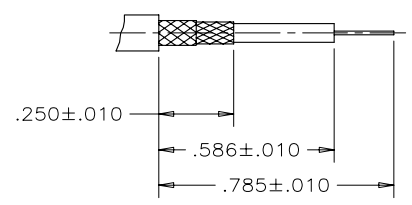
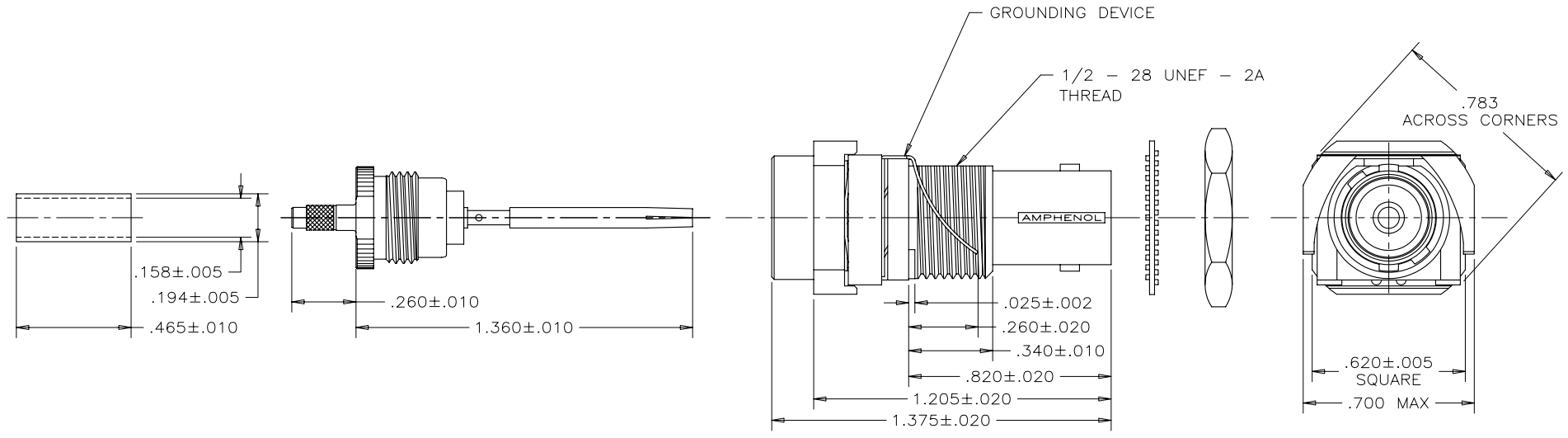

RECOMMENDED CABLE (RD-179)
STRIPPING DIM'S
CABLE IMPEDANCE: 75 OHM

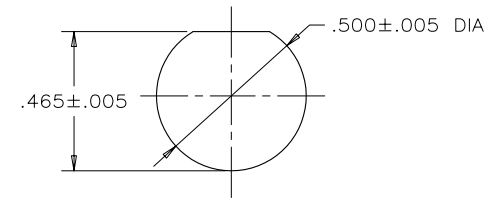

RECOMMENDED PANEL CUTOUT

CRIMP WITH AMPHENOL TOOL 227-944 (M22520/5-01)
AND DIE SET 227-980-2 CAVITY 'A'

AMPHENOL PART NO.: 456E-218SL
SEE SHEET 1 FOR MECHANICAL AND ELECTRICAL SPECIFICATIONS.

DRAWN <i>S.BUENAVIDES</i>	DATE <i>DEC01/05</i>	Amphenol Canada Corp.	
CHECKED <i>K.LAMBIE</i>	DATE <i>DEC02/05</i>		
DESIGNED		TITLE 456E SERIES B.N.C. REAR MOUNT CAPACITIVELY DECOUPLED CONNECTOR, 10,000 pF, 75 OHM, CRIMP, RoHS COMPLIANT	
APPROVED		DWG	REV.
INDUSTRIAL ENG. APPRD.		C	A
ENGINEERING RELEASE NO.		DRAWING NO. P-456E-218XX	
REF.		SCALE 3/1	WT. _____
DIMENSIONS ARE IN INCHES	CODE IDENT. NO. 03554	SURF. _____	SHEET 2 OF 3

THIS DOCUMENT CONTAINS PROPRIETARY INFORMATION AND SUCH INFORMATION MAY NOT BE DISCLOSED TO OTHERS FOR ANY PURPOSE OR USED FOR MANUFACTURING PURPOSES WITHOUT WRITTEN PERMISSION FROM AMPHENOL CANADA CORP.

ASSEMBLY INSTRUCTIONS FOR P/N 456E-218 & 456E-218S

REVISIONS			
REV	ECN, ERN NO.	DATE	APPRD.
A	PRODUCT DRAWING	DEC01/05	K.L.

OUTER FERRULE

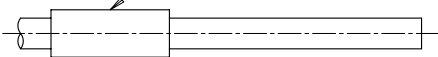

STEP 1
SLIDE OUTER FERRULE ONTO CABLE AS SHOWN PRIOR TO STRIPPING CABLE.



STEP 2
STRIP CABLE JACKET, BRAID AND DIELECTRIC TO DIMENSIONS SHOWN ON SHEET 1. ALL CUTS ARE TO BE SHARP AND SQUARE. IMPORTANT: DO NOT NICK BRAID, DIELECTRIC AND CENTRE CONDUCTOR WHEN CUTTING. TIN CENTRE CONDUCTOR USING SOFT SOLDER PER QQ-S-571 COMP Sn 60. AVOID EXCESSIVE HEAT WHILE TINNING TO PREVENT SWELLING OF CABLE DIELECTRIC.



STEP 3
SLIGHTLY FLARE OUT END OF CABLE BRAID AS SHOWN SO AS TO FACILITATE INSERTION ONTO CENTRE CONTACT SUB-ASSEMBLY. IMPORTANT: DO NOT COMB OUT BRAID.

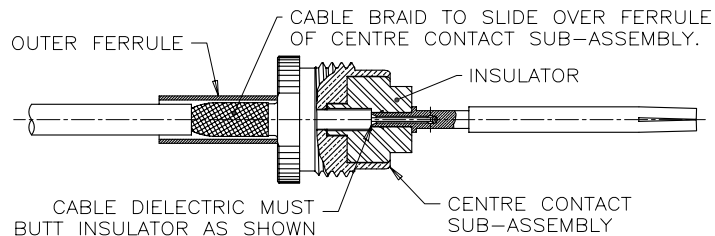

STEP 4
INSTALL CENTRE CONTACT SUB-ASSEMBLY ONTO CABLE SO THAT FERRULE PORTION SLIDES UNDER BRAID AND INSULATOR BUTTS FLUSH AGAINST CABLE DIELECTRIC. SLIDE OUTER FERRULE OVER BRAID AND UP AGAINST SHOULDER OF CENTRE CONTACT SUB-ASSEMBLY. MAKE SURE NO SLACK EXISTS IN BRAID. CRIMP OUTER FERRULE WITH TOOL SPECIFIED ON SHEET 1, KEEPING CABLE DIELECTRIC BOTTOMED AGAINST INSULATOR.

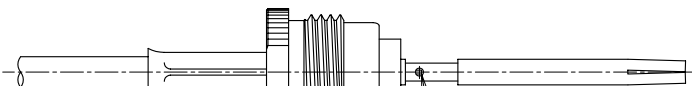

OUTER FERRULE MUST CLAMP CENTRE CONTACT SUB-ASSEMBLY AS SHOWN.
NOTE: CENTRE CONDUCTOR MUST BE VISIBLE THROUGH CONTACT SOLDER HOLE PRIOR TO SOLDERING.

STEP 5
SOFT SOLDER CENTRE CONDUCTOR TO CONTACT USING ROSIN CORE PER QQ-S-571 COMP Sn 60. DO NOT GET ANY SOLDER ON OUTSIDE SURFACES OF CONTACT.

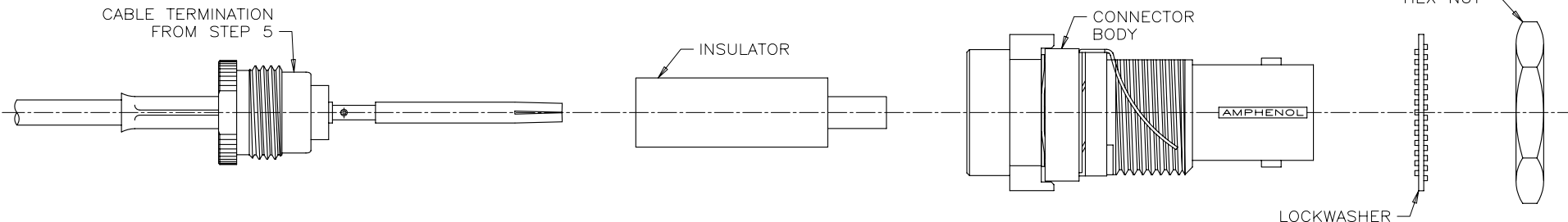

STEP 6
SLIDE INSULATOR INTO CONNECTOR BODY AND SCREW THE ASSEMBLY ONTO THE PREPARED CABLE TERMINATION. WRENCH TIGHTEN BY HOLDING THE CENTRE CONTACT SUB-ASSEMBLY STATIONARY WHILE ROTATING THE CONNECTOR BODY. SLIDE CONNECTOR INTO THE PANEL OPENING AND INSTALL LOCKWASHER AND HEX NUT TO HOLD IT IN PLACE.

MATERIAL	DRAWN S.BUENAVIDES	DATE DEC01/05
	CHECKED K.LAMBIE	DATE DEC02/05
	DESIGNED	
	APPROVED	
	INDUSTRIAL ENG. APPRD.	
	ENGINEERING RELEASE NO.	
FINISH	REF.	DIMENSIONS ARE IN CODE IDENT. NO.
		INCHES 0.3554

Amphenol Canada Corp.		
TITLE 456E SERIES B.N.C. REAR MOUNT CAPACITIVELY DECOUPLED CONNECTOR, 10,000 pF, 75 OHM, CRIMP, RoHS COMPLIANT		
DWG C	DRAWING NO. P-456E-218XX	REV. A
SCALE 3/1	WT. -----	SURF. -----
SHEET 3 OF 3		

THIS DOCUMENT CONTAINS PROPRIETARY INFORMATION AND SUCH INFORMATION MAY NOT BE DISCLOSED TO OTHERS FOR ANY PURPOSE OR USED FOR MANUFACTURING PURPOSES WITHOUT WRITTEN PERMISSION FROM AMPHENOL CANADA CORP.

X-ON Electronics

Largest Supplier of Electrical and Electronic Components

Click to view similar products for [RF Connectors / Coaxial Connectors](#) category:

Click to view products by [Amphenol](#) manufacturer:

Other Similar products are found below :

[8915-1511-000](#) [89674-0827](#) [6001-7071-019](#) [6002-7051-003](#) [6002-7551-202](#) [6059674-1](#) [619550-1](#) [630059-000](#) [M39030/3-01N](#) [M3933/25-36N](#) [6500-7071-046](#) [6769](#) [CX050L2AQ](#) [7002-1542-011](#) [7004-1512-000](#) [7009-1511-004](#) [7010-1511-000](#) [7029-1511-060](#) [7101-1541-010](#) [7101-1571-002](#) [7105-1521-002](#) [7145-1521-002](#) [7203-1571-003](#) [7209-1511-011](#) [7210-1511-015](#) [7210-1511-019](#) [73137-5015](#) [73216-2241](#) [7325-1512-000](#) [73404-2300](#) [7405-1521-005](#) [7405-1521-802](#) [7406-1521-005](#) [8527](#) [8547](#) [FS11V](#) [8808-1511-001](#) [9049-9513-000](#) [9074-9513-000](#) [9101-9573-002](#) [910A205F](#) [9130-9573-002](#) [PL11SC-026](#) [PL375-33](#) [PL40-5](#) [PL71-9](#) [PL74C-221](#) [PL75MC-217](#) [PL803-7](#) [980-8666-005](#)