

PRODUCT NO.  
SEE SHT.2

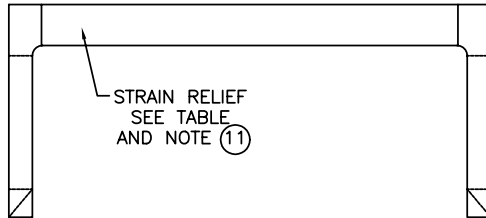

SLOT DIM S

1.27 [0.050] TYP.

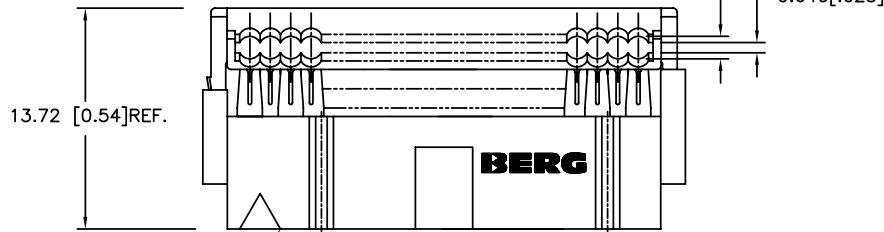

TRIANGLE INDICATES POSITION ONE

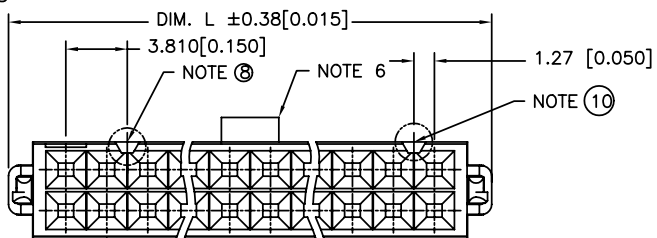

2.54 [0.100] TYP.

SIDE VIEW OF ASS'Y.  
AFTER TERMINATION

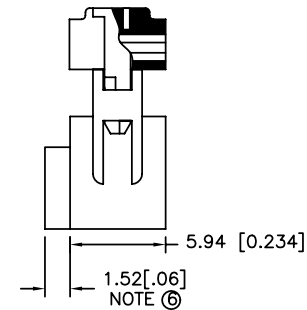
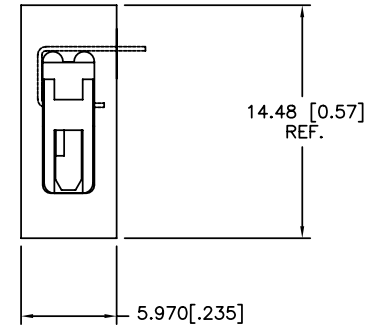

Copyright FCI.

| mat'l. code |          |      |            | tolerances unless otherwise specified |                       |                | CUSTOMER COPY                      | FCI<br>www.fciconnect.com |        |
|-------------|----------|------|------------|---------------------------------------|-----------------------|----------------|------------------------------------|---------------------------|--------|
| ltr         | ecr no   | dr   | date       | linear                                | .xx ±.01/.x±.3        | projection<br> | title                              |                           |        |
| G           | 5003     | BLI  | 1983-08-02 | angles                                | .xxx ±.005/.xxx±.13   |                | QUICKIE L.P ASS'Y<br>STRAIN RELIEF |                           |        |
| H           | N10816   | CN   | 1988-10-05 |                                       | .xxx ±.0020/.xxx±.051 |                | product family QUICKIE             |                           |        |
| J           | V81770   | RGD  | 1998-10-02 |                                       | 0° ±2°                | INCH/MM<br>↔   | code                               |                           |        |
| K           | V90536   | RGD  | 1999-03-02 | R.G. DRAGG00                          | 10/2/98               |                | NT                                 |                           |        |
| L           | N05-0060 | MHT  | 2005-03-04 | engr                                  | M.SYMK                | 10/2/98        | sheet                              |                           |        |
| M           | N09-0400 | A.ZH | 2010-01-18 | chr                                   | M.SYMK                | 10/2/98        | 1 of 2                             |                           |        |
| sheet index |          |      |            | revision                              | M                     |                | scale                              | size                      | dwg no |
| 1-2         |          |      |            |                                       |                       |                | 1:1                                | A4                        | 66564  |

| PRODUCT NO. | SIZE | DIM "L"       | DIM "S"        | LEAD FREE OPTION |
|-------------|------|---------------|----------------|------------------|
| 66564-X06   | 2x3  | 12.19/[.480]  | 8.128/[.320]   | NOTE<br>13, 14   |
| 66564-X08   | 2x4  | 14.73/[.580]  | 10.668/[.420]  |                  |
| 66564-X10   | 2x5  | 17.27/[.680]  | 13.210/[.520]  |                  |
| -X14        | 2x7  | 22.35/[.880]  | 18.290/[.720]  |                  |
| -X16        | 2x8  | 24.89/[.980]  | 20.830/[.820]  |                  |
| -X20        | 2x10 | 29.97/[1.180] | 25.910/[1.020] |                  |
| -X26        | 2x13 | 37.59/[1.480] | 33.530/[1.320] |                  |
| -X34        | 2x17 | 47.75/[1.880] | 43.690/[1.720] |                  |
| -X40        | 2x20 | 55.37/[2.180] | 51.310/[2.020] |                  |
| -X50        | 2x25 | 68.07/[2.680] | 64.010/[2.520] |                  |
| 66564-X60   | 2x30 | 80.77/[3.180] | 76.710/[3.020] |                  |

| KEY | X    | COVER |       | POL. KEY | STR REL. | SEE NOTE 12 |
|-----|------|-------|-------|----------|----------|-------------|
|     |      | STYLE | ENTRY |          |          |             |
| 5   | THRU | DUAL  | NO    | NO       | NO       | SEE NOTE 11 |
| 6   | THRU | DUAL  | NO    | NO       | NO       | SEE NOTE 11 |
| 7   | THRU | DUAL  | YES   | NO       | NO       | SEE NOTE 11 |
| 8   | THRU | DUAL  | YES   | YES      |          |             |
| 9   | THRU | DUAL  | NO    | YES      |          |             |

**NOTES:**

1. TERMINAL MAT'L: PHOS BRONZE, FULL HARD, ALLOY UNS-C51000.
2. TERMINAL PLATING: 50u"/1.27um MIN Ni UNDERPLATE OVER ENTIRE TERMINAL AND 30u"/0.76um MIN Au OR GXT IN CONTACT AREA ONLY;
3. MOLDING MAT'L: BASE AND COVER-GLASS FILLED POLYESTER, FLAME RETARDANT PER UL 94V-0: COLOR- BLUE.
4. CONNECTOR ASS'YS PACKAGED IN TUBESTHEN BOXED IN LOTS OF 100.
5. THE FIRST TWO CAVITY POSITIONS AND THE LAST TWO ARE IDENTIFIED BY NUMBER.
6. POLARIZING FEATURE OPTIONAL , SEE TABLE.
7. MOLDING MAT'L: STRAIN RELIEF-UNFILLED THERMOPLASTIC, FLAME-RETARDANT:UL 94 V-0: COLOR-BLUE.
8. THE POLARIZING FEATURE ON THIS END IS NON EXISTENT ON 6,8,10, AND 14 POS. CONNECTORS.
9. 10 POSITION CONNECTOR NOT AVAILABLE WITH BOTH POL. SLOTS AND KEY.
10. THE POLARIZING FEATURE ON THIS END IS NON EXISTENT ON 6 AND 8 POS. CONNECTORS.
11. THE PRODUCT NUMBERS 66564-6XX AND 66564-7XX ONLY COUNT FOR 2x3 AND 2x4 POS. CONNECTORS FOR ALL OTHER VERSIONS WITHOUT STRAIN RELIEF (2x5---2x30) REFER TO P/N 66900
12. PRODUCT NUMBER 66564-506 ONLY WITHOUT BERG LOGO.
13. ADD "LF" SUFFIX AT THE END OF PART NUMBER FOR LEAD FREE OPTION.
14. THESE PRODUCTS MEET EUROPEAN UNION DIRECTIVES AND OTHER COUNTRY REGULATION AS DESCRIBED IN GS-22-008.
15. THE PRODUCT IS NOT INTENDED TO BE EXPOSED TO A MANUFACTURING SOLDER PROCESS.
16. PRODUCT SPEC. BUS-12-082
17. PLATING OPTIONS: MAY BE EITHER GOLD OR GXT PLATED AT MANUFACTURER'S OPTION.

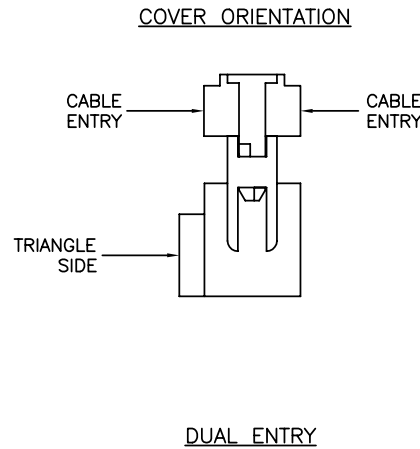

Copyright FCI.

|                                       |                            |                   |  |                |
|---------------------------------------|----------------------------|-------------------|--|----------------|
| tolerances unless otherwise specified |                            | CUSTOMER COPY     | FCI<br>www.fciconnect.com                    |                |
| linear                                | . XX ± .01/. Xt. 3         | projection<br>⊕ ← | title<br>QUICKIE L. P ASS'Y<br>STRAIN RELIEF |                |
|                                       | . XXX ± .005/. XX±. 13     |                   | product family QUICKIE                       | code<br>NT     |
|                                       | . XXXX ± .0020/. XXX±. 051 |                   |  | size<br>dwg no |
| angles                                | 0° ±2°                     | INCH/MM           | scale<br>1: 1                                | A4             |
| dr                                    | R.G. DRAGGOO               | 10/2/98           | 66564  |                |
| engr                                  | M.SYMK                     | 10/2/98           | sheet<br>2 of 2                              |                |
| chr                                   | M.SYMK                     | 10/2/98           |  |                |
| appd                                  | M.SYMK                     | 10/2/98           |  |                |

## X-ON Electronics

Largest Supplier of Electrical and Electronic Components

*Click to view similar products for [Headers & Wire Housings](#) category:*

*Click to view products by [Amphenol](#) manufacturer:*

Other Similar products are found below :

[892-18-020-10-001101](#) [58102-G61-06LF](#) [582553-1](#) [0009485154](#) [009176003701906](#) [0050291907](#) [LY20-4P-DT1-P1E-BR](#) [02.125.8002.8](#)  
[609-3404](#) [61062-3](#) [622-0430](#) [622-3653LF](#) [63453-116](#) [636-1030](#) [636-1427](#) [636-3427](#) [636-4007](#) [641938-9](#) [641991-4](#) [644827-2](#) [65817-010LF](#)  
[65817-015LF](#) [65863-015LF](#) [66207-023LF](#) [67095-007LF](#) [67601157](#) [68648-049](#) [70.362.1628.0](#) [70-4210](#) [70-4226B](#) [70-4853B](#) [707-5020](#) [707-](#)  
[5028](#) [71.350.2428.0](#) [71918-208LF](#) [71961-016LF](#) [733-134](#) [733-162](#) [754199-000](#) [760-3052](#) [787-8014-00](#) [79531-3000](#) [FCN-360C032-B](#) [FCN-](#)  
[367T-T012/H](#) [FCN-723D010/2](#) [80.063.4001.1](#) [800-90-001-10-001000](#) [800-90-010-10-002000](#) [801-43-002-10-013000](#) [801-43-006-10-002000](#)