

PRODUCT NUMBER
SEE TABLE

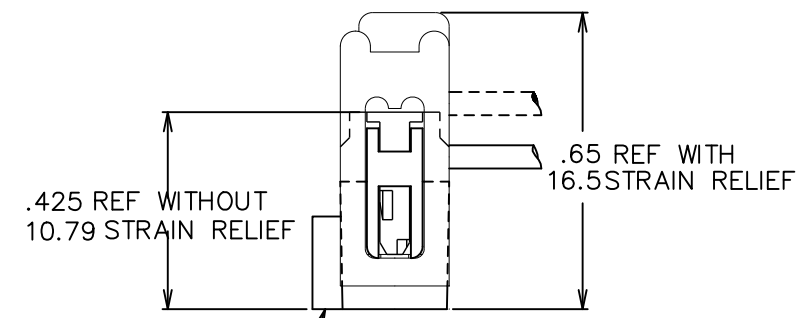

TRIANGLE INDICATES POSITION #1

"FCI" LOGO POSITION AREA, THICKNESS 0.03 ± 0.02 mm
(THE TEXT CAN BE HORIZONTAL OR VERTICAL, NEED VISUAL CLEAR)

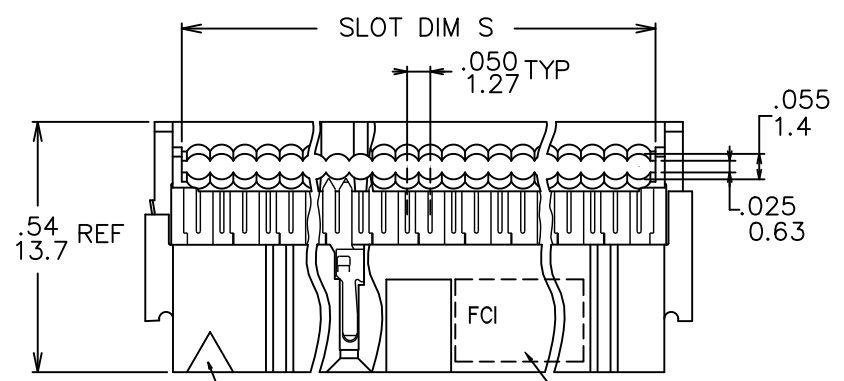
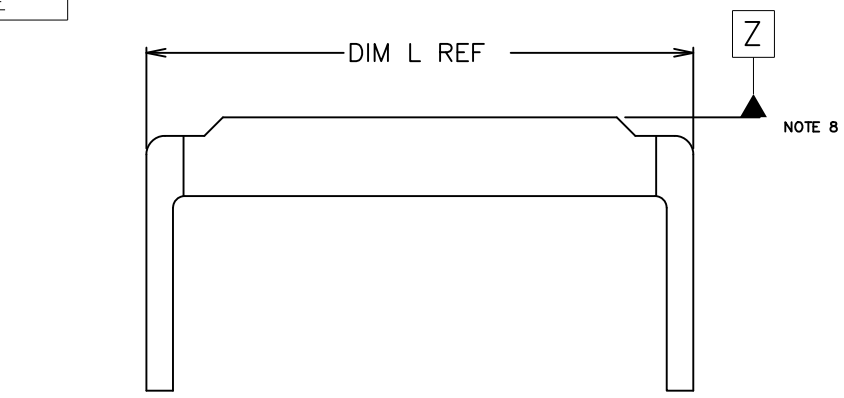
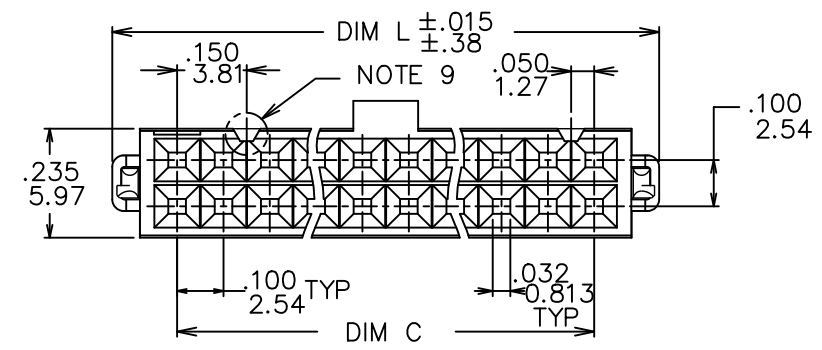

mat'l. code		surface ISO 1302 ✓		tolerance ISO 406 ISO 1101		projection MM		product family QUICKIE	
ltr	ecn no	dr	date	tolerances unless otherwise specified		title		title	
T	N09-0400	A.ZH	2010-01-18	angles	linear	MM		DUAL POLARIZED QUICKIE II ASSEMBLY	
U	ELX-N-011958	JZ	2012-06-15	0°±2'		scale 1:1		dwg no	
V	ELX-N-13342	DCS	2012-11-01			Amphenol FCI		sheet 1 of 2	
W	ELX-N-32562	MZ	2019-01-28	dr	MIKE ZHOU	2018/07/20	66900		size A3
				enr	MIKE ZHOU	2018/07/20	type		Product Customer
				chr	TIM YAO	2018/07/20	Drawing		
				appd	TIM YAO	2018/07/20			
sheet	revision	W	W						
index	sheet	1	2						

Amphenol
FCI

© 2016 AFCI

PRODUCT No. NOTE 12	SIZE	DIM L	DIM S	DIM C
66900-X10	2X5	.680/17.27	.520/13.21	.400/10.16
-X14	2X7	.880/22.35	.720/18.29	.600/15.24
-X16	2X8	.980/24.89	.820/20.83	.700/17.78
-X20	2X10	1.180/29.97	1.020/25.91	.900/22.86
-X24	2X12	1.380/35.05	1.220/30.99	1.100/27.94
-X26	2X13	1.480/37.59	1.320/33.53	1.200/30.48
-X30	2X15	1.680/42.67	1.520/38.61	1.400/35.56
-X34	2X17	1.880/47.75	1.720/43.69	1.600/40.64
-X40	2X20	2.180/55.37	2.020/51.31	1.900/48.26
-X44	2X22	2.380/60.45	2.220/56.39	2.100/53.34
-X50	2X25	2.680/68.07	2.520/64.01	2.400/60.96
66900-X60	2X30	3.180/80.77	3.020/76.71	2.900/73.66

DASH NO	COVER		POLARIZATION	STRAIN RELIEF
	STYLE	ORIENTATION		
-0XX	THRU	DUAL ENTRY	DUAL POL.	YES
-1XX	THRU	DUAL ENTRY	DUAL POL.	NO
-2XX	THRU	DUAL ENTRY	CENTER KEY & DUAL POL.	YES
-3XX	THRU	DUAL ENTRY	CENTER KEY & DUAL POL.	NO
-4XX	BLIND	RIGHT	DUAL POL.	YES
-5XX	BLIND	RIGHT	DUAL POL.	NO
-6XX	BLIND	LEFT	DUAL POL.	YES
-7XX	BLIND	LEFT	DUAL POL.	NO
-8XX	BLIND	RIGHT	CENTER KEY & DUAL POL.	YES
-9XX	BLIND	LEFT	CENTER KEY & DUAL POL.	YES

DASH NO	COVER		POLARIZATION	STRAIN RELIEF	NOTE
	STYLE	ORIENTATION			
-AXX	BLIND	LEFT	DUAL POL.	NO	NOTE 17
-BXX	THRU	DUAL ENTRY	DUAL POL.	YES	
-CXX	THRU	DUAL ENTRY	DUAL POL.	NO	
-DXX	THRU	DUAL ENTRY	CENTER KEY & DUAL POL.	NO	
-EXX	BLIND	RIGHT	DUAL POL.	YES	
-FXX	BLIND	RIGHT	DUAL POL.	NO	

COVER ORIENTATION

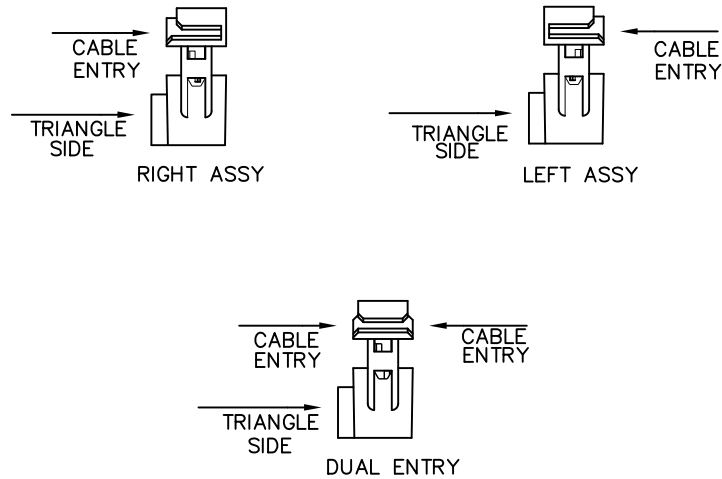

NOTES:

1. TERMINAL MATERIAL: FULL HARD PHOS. BRONZE ALLOY, UNS-C51000.
2. TERMINAL PLATING: 50u"/27u MIN NI UNDERPLATE OVER ENTIRE TERMINAL AND 30u"/.76u MIN Au OR GXT IN CONTACT AREA ONLY.
3. MOLDING MATERIAL: BASE & COVER- GLASS FILLED POLYESTER, FLAME RETARDANT PER UL94V-0, COLOR- BLUE.
4. CONNECTOR ASSEMBLIES PACKAGED IN TUBES.
5. THE FIRST TWO CAVITY POSITIONS AND THE LAST TWO, ARE IDENTIFIED BY NUMBER.
6. POLARIZING FEATURES ARE DESCRIBED IN TABLE.
7. MOLDING MATERIAL: STRAIN RELIEF- NYLON, FLAME RETARDANT PER UL94V-0, COLOR- BLUE.
8. STRAIN RELIEF DIM APPLIES WHEN DATUM -Z- IS HELD IN A RESTRAINED CONDITION.
9. THE POLARIZING FEATURE ON THIS END IS NON-EXISTANT ON 2X5 AND 2X7 POSITION CONNECTORS.
10. 2x5 POSITION NOT AVAILABLE WITH POLARIZATION SLOT ON CENTER KEY STYLE.
11. TO ORDER PARTS THAT DO NOT HAVE "MARKED INFO", (DATE, P/N, ETC), ADD A "U" AFTER THE PART NUMBER. EXAMPLE 66900-010 U.
12. ADD "LF" SUFFIX AT THE END OF PART NUMBER FOR LEAD FREE OPTION.
13. IF "LF" P/N THE PRODUCT MEETS EUROPEAN UNION DIRECTIVES AND OTHER COUNTRY REGULATION AS DESCRIBED IN GS-22-008.
14. THE PRODUCT IS NOT INTENDED TO BE EXPOSED TO A MANUFACTURING SOLDER PROCESS.
15. PRODUCT SPEC. BUS-12-082
16. PLATING OPTIONS: MAY BE EITHER GOLD OR GXT PLATED AT MANUFACTURER'S OPTION.
17. FOR CUSTOMER SPECIAL REQUIREMENT. TERMINAL PLATING: 50u"/27u MIN NI UNDERPLATE OVER ENTIRE TERMINAL AND 30u"/.76u MIN Au IN CONTACT AREA ONLY.

mat'l. code		surface ISO 1302 ✓	tolerance ISO 406 ISO 1101	projection MM scale 1:1	product family QUICKIE
ltr	ecn no	dr	date	tolerances unless otherwise specified	title DUAL POLARIZED QUICKIE II ASSEMBLY
W				angles linear 0°±2'	dwg no 66900
				dr MIKE ZHOU 2018/07/20	sheet 2 of 2
				engr MIKE ZHOU 2018/07/20	size A3
				chr TIM YAO 2018/07/20	type Product Customer Drawing
				appd TIM YAO 2018/07/20	
sheet	revision				
index	sheet				

X-ON Electronics

Largest Supplier of Electrical and Electronic Components

Click to view similar products for [Headers & Wire Housings](#) category:

Click to view products by [Amphenol](#) manufacturer:

Other Similar products are found below :

[892-18-020-10-001101](#) [58102-G61-06LF](#) [582553-1](#) [0009485154](#) [009176003701906](#) [0050291907](#) [LY20-4P-DT1-P1E-BR](#) [02.125.8002.8](#)
[609-3404](#) [61062-3](#) [622-0430](#) [622-3653LF](#) [63453-116](#) [636-1030](#) [636-1427](#) [636-3427](#) [636-4007](#) [641938-9](#) [641991-4](#) [644827-2](#) [65817-010LF](#)
[65817-015LF](#) [65863-015LF](#) [66207-023LF](#) [67095-007LF](#) [67601157](#) [68648-049](#) [70.362.1628.0](#) [70-4210](#) [70-4226B](#) [70-4853B](#) [707-5020](#) [707-](#)
[5028](#) [71.350.2428.0](#) [71918-208LF](#) [71961-016LF](#) [733-134](#) [733-162](#) [754199-000](#) [760-3052](#) [787-8014-00](#) [79531-3000](#) [FCN-360C032-B](#) [FCN-](#)
[367T-T012/H](#) [FCN-723D010/2](#) [80.063.4001.1](#) [800-90-001-10-001000](#) [800-90-010-10-002000](#) [801-43-002-10-013000](#) [801-43-006-10-002000](#)