

PRODUCT NUMBER
SEE TABLE

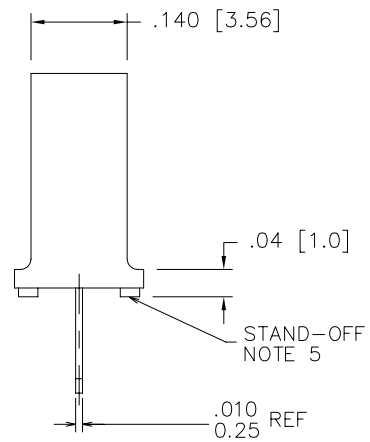
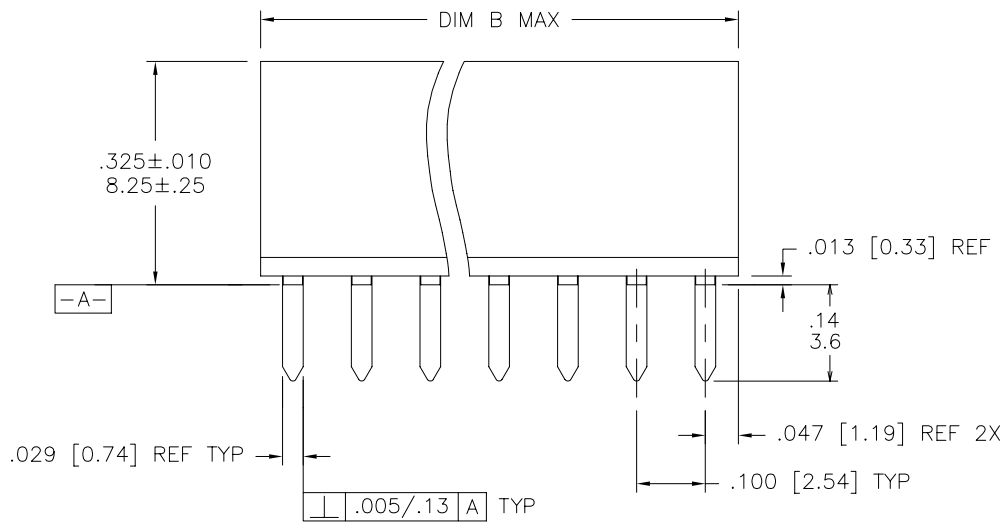
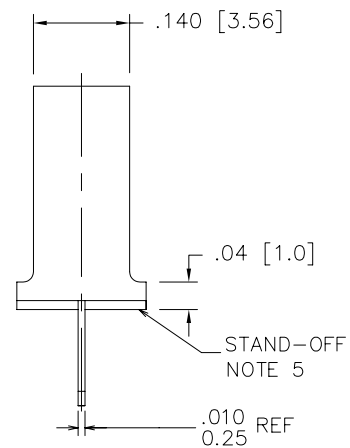
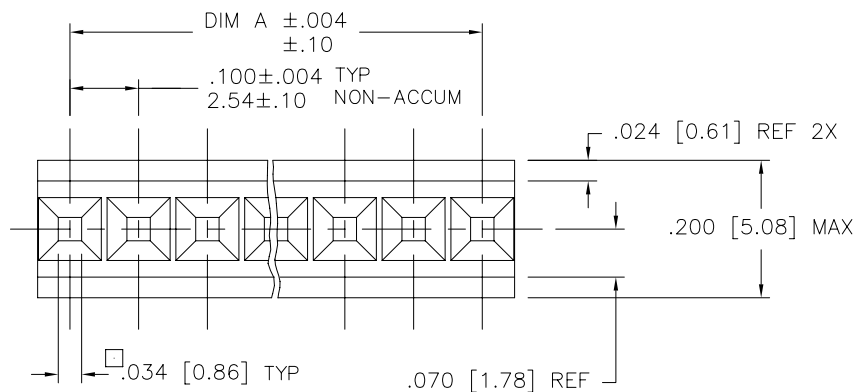

Copyright FCI

mat'l. code		surface		tolerance		projection		product family	
NOTES 1 & 2		ISO 1302 ✓		ISO 406 ISO 1101		⊕		CARD CONN	
ltr	ecn	no	dr	date	tolerances unless otherwise specified			title	
F	V11848	JGS		7/2/91	angles	linear	.XX±.01/.X±.3	VERTICAL CARD CONNECTOR	
G	V23245	MRC		10/13/92			.XXX±.0.005/.XX±.13	.100/2.54 CTR. SINGLE. ROW	
H	V70789	MDF		8/14/97	0°±2'		.XXXX±.0020/.XXX±.051	scale 4:1	
J	V94468	MDF		1/7/00	dr	J.SHREINER	12/11/90	dwg no	
K	M05-0216	ERE		10/11/05	engr	M.HAHN	12/11/90	sheet 1 of 4 size	
L	M06-0210	MHT		6/03/06	chr	M.HAHN	12/11/90	66951 A3	
M	M07-0143	ERE		03/03/07	appd	M.HAHN	12/11/90	type Product Customer Drawing	
sheet	revision	M	M	M	M	M			
index	sheet	1	2	3	4				

form: A3

PRODUCT NUMBER
SEE TABLE

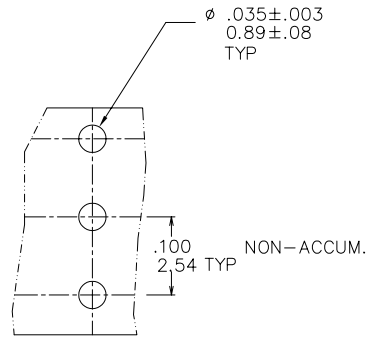

FIG.1
SCALE 5/1

NOTES:

- ① HOUSING MATERIAL: FILLED POLYESTER, FLAME RETARDANT PER UL 94V-0.
COLOR: BLACK.
- ② TERMINAL MATERIAL:
BODY: BRASS
SPRING: BeCu. HEAT TREATED
BODY PLATING: 30u"/.76u Au OVER 50u" /1.27u Ni IN CONTACT AREA.
100u"/2.54u Sn (NOTE 9) OVER 50u" /1.27u Ni ON SOLDERTAIL.
SPRING PLATING: GOLD FLASH
3. MARKED FCI PART NUMBER & DATE CODE LEGIBLE ON TUBE LABEL.
4. APPLICATION INFORMATION.
A. RECOMMENDED MOUNTING HOLE PATTERN IS SHOWN IN FIG. #1.
B. ALL MATING PINS TO BE .025/.64 SQUARE ON TRUE CENTER OF GIVEN TERMINAL SPACINGS, WITHIN .015/.38 DIAMETER.
C. SUGGESTED MATING PIN LENGTH, .210 ± .020/5.33 ± .51.
- ⑤ STAND-OFF CONFIGURATION:
BUMP OR RIB AT MANUFACTURERS' OPTION.
- ⑥ ADD "LF" SUFFIX AT THE END OF PART NUMBER FOR LEAD FREE OPTION.
- ⑦ THESE PRODUCTS MEET EUROPEAN UNION DIRECTIVES AND OTHER COUNTRY REGULATIONS AS DESCRIBED IN GS-22-008.
8. THIS PART WILL WITHSTAND EXPOSURE TO 260°C PEAK TEMPERATURE FOR 20 SECONDS IN WAVE SOLDER, INFRA-RED OR VAPOR PHASE SOLDER PROCESS.
- ⑨ "THIS PRODUCT HAS 100% TIN PLATING IN THE INTERFACE AND HAS NOT BEEN TESTED FOR WHISKER GROWTH IN ALL INTERCONNECT ENVIRONMENTS."

FCI
FCIconnect.com

Copyright FCI

mat'l. code		surface ISO 1302 ✓		tolerance ISO 406 ISO 1101		projection 		product family CARD CONN	
ltr		ecn no dr		date		tolerances unless otherwise specified		title	
M						.XX ± .01 / .X ± .3		VERTICAL CARD CONNECTOR	
				angles		linear		INCH/MM	
				0° ± 2'		.XXX ± 0.005 / .XX ± .13		.100/2.54 CTR. SINGLE. ROW	
						.XXXX ± .0020 / .XXX ± .051		scale 4:1	
				dr		J.SHREINER 12/11/90		dwg no	
				enr		M.HAHN 12/11/90		sheet 2 of 4 size	
				chr		M.HAHN 12/11/90		66951 A3	
				appd		M.HAHN 12/11/90		type Product Customer Drawing	
sheet index		revision sheet							

PRODUCT NO	NO. OF POS	DIM A	DIM B	DESC P/N ON -8XX SERIES ONLY	LEAD FREE OPTION
66951-Y01	U N A S S I G N E D				
-Y02	1X2	.100/2.54	.200/5.08	WWWWW-02	OBS NOTE 6,7 NOTE 6,7
-Y03	1X3	.200/5.08	.300/7.62	WWWWW-03	
-Y04	1X4	.300/7.62	.400/10.16	WWWWW-04	
-Y05	1X5	.400/10.16	.500/12.70	WWWWW-05	
-Y06	1X6	.500/12.70	.600/15.24	WWWWW-06	
-Y07	1X7	.600/15.24	.700/17.78	WWWWW-07	
-Y08	1X8	.700/17.78	.800/20.32	WWWWW-08	
-Y09	1X9	.800/20.32	.900/22.86	WWWWW-09	
-Y10	1X10	.900/22.86	1.000/25.40	WWWWW-10	
-Y11	1X11	1.000/25.40	1.100/27.94	WWWWW-11	
-Y12	1X12	1.100/27.94	1.200/30.48	WWWWW-12	
-Y13	1X13	1.200/30.48	1.300/33.02	WWWWW-13	
-Y14	1X14	1.300/33.02	1.400/35.56	WWWWW-14	
-Y15	1X15	1.400/35.56	1.500/38.10	WWWWW-15	
-Y16	1X16	1.500/38.10	1.600/40.64	WWWWW-16	
-Y17	1X17	1.600/40.64	1.700/43.18	WWWWW-17	
-Y18	1X18	1.700/43.18	1.800/45.72	WWWWW-18	
-Y19	1X19	1.800/45.72	1.900/48.26	WWWWW-19	
-Y20	1X20	1.900/48.26	2.000/50.80	WWWWW-20	
-Y21	1X21	2.000/50.80	2.100/53.34	WWWWW-21	
-Y22	1X22	2.100/53.34	2.200/55.88	WWWWW-22	
-Y23	1X23	2.200/55.88	2.300/58.42	WWWWW-23	
-Y24	1X24	2.300/58.42	2.400/60.96	WWWWW-24	
66951-Y25	1X25	2.400/60.96	2.500/63.50	WWWWW-25	



FCIconnect.com

Copyright FCI

mat'l. code		surface ISO 1302 <input checked="" type="checkbox"/>		tolerance ISO 406 ISO 1101		projection 		product family CARD CONN		
ltr	ecn	no	dr	date		tolerances unless otherwise specified		title		
M						angles	linear	INCH/MM		
						0'±2'	.XX±.01/.X±.3 .XXX±.0.005/.XX±.13 XXXX±.0020/.XXX±.051	scale 4:1		
				dr	J.SHREINER	12/11/90			sheet 3 of 4 size	
				enr	M.HAHN	12/11/90			dwg no	66951
				chr	M.HAHN	12/11/90			type	Product Customer Drawing
				appd	M.HAHN	12/11/90				A3
sheet index	revision sheet									

PRODUCT NO	NO. OF POS	DIM A	DIM B	DESC P/N ON -8XX SERIES ONLY	LEAD FREE OPTION
66951-Y26	1X26	2.500/63.50	2.600/66.04	WWWWW-26	NOTE 6,7
-Y27	1X27	2.600/66.04	2.700/68.58	WWWWW-27	
-Y28	1X28	2.700/68.58	2.800/71.12	WWWWW-28	
-Y29	1X29	2.800/71.12	2.900/73.66	WWWWW-29	
-Y30	1X30	2.900/73.66	3.000/76.20	WWWWW-30	
-Y31	1X31	3.000/76.20	3.100/78.74	WWWWW-31	
-Y32	1X32	3.100/78.74	3.200/81.28	WWWWW-32	
-Y33	1X33	3.200/81.28	3.300/83.82	WWWWW-33	
-Y34	1X34	3.300/83.82	3.400/86.36	WWWWW-34	
-Y35	1X35	3.400/86.36	3.500/88.90	WWWWW-35	
66951-Y36	1X36	3.500/88.90	3.600/91.44	WWWWW-36	



FCJconnect.com

Copyright FCJ

mat'l. code		surface ISO 1302	tolerance ISO 406 ISO 1101	projection 	product family CARD CONN
ltr	ecn no	dr	date	tolerances unless otherwise specified	title
M				angles linear 0°±2'	VERTICAL CARD CONNECTOR 100/2.54 CTR. SINGLE. ROW
				dr J.SHREINER 12/11/90 enr M.HAHN 12/11/90 chr M.HAHN 12/11/90 appd M.HAHN 12/11/90	dwg no 66951 sheet 4 of 4 size A3
sheet index	revision sheet				type Product Customer Drawing



form: A3

X-ON Electronics

Largest Supplier of Electrical and Electronic Components

Click to view similar products for [Headers & Wire Housings](#) category:

Click to view products by [Amphenol](#) manufacturer:

Other Similar products are found below :

[892-18-020-10-001101](#) [58102-G61-06LF](#) [582553-1](#) [0009485154](#) [009176003701906](#) [0050291907](#) [LY20-4P-DT1-P1E-BR](#) [02.125.8002.8](#)
[609-3404](#) [61062-3](#) [622-0430](#) [622-3653LF](#) [63453-116](#) [636-1030](#) [636-1427](#) [636-3427](#) [636-4007](#) [641938-9](#) [641991-4](#) [644827-2](#) [65817-010LF](#)
[65817-015LF](#) [65863-015LF](#) [66207-023LF](#) [67095-007LF](#) [67601157](#) [68648-049](#) [70.362.1628.0](#) [70-4210](#) [70-4226B](#) [70-4853B](#) [707-5020](#) [707-](#)
[5028](#) [71.350.2428.0](#) [71918-208LF](#) [71961-016LF](#) [733-134](#) [733-162](#) [754199-000](#) [760-3052](#) [787-8014-00](#) [79531-3000](#) [FCN-360C032-B](#) [FCN-](#)
[367T-T012/H](#) [FCN-723D010/2](#) [80.063.4001.1](#) [800-90-001-10-001000](#) [800-90-010-10-002000](#) [801-43-002-10-013000](#) [801-43-006-10-002000](#)