

PRODUCT NUMBER

XXXXX-YYYHXLFX

ADDITIONAL CODE
(SEE NOTES 1)

LEAD FREE OPTION
(SEE NOTES 1)

PACKAGING OPTIONS
(SEE NOTE 1)

HIGH TEMPERATURE PLASTIC
(SEE NOTE 1)

NO OF POSITIONS
(SEE NOTE 1)

PIN PLATING
(SEE SHEET 2)

BASE PART NO.

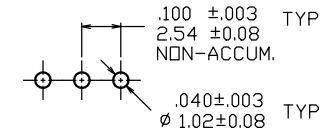
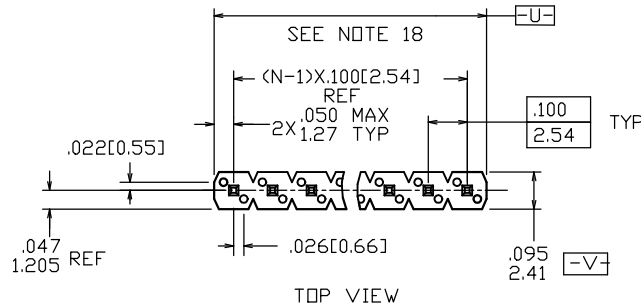

68000-X XX-XXX XXX LF

TAIL LENGTH (EXAMPLE BELOW)
3.0mm=030 12.8mm=128 (SEE NOTE 15 & 16)

MATING LENGTH (EXAMPLE BELOW)
5.0mm=050 25.5mm=255 (SEE NOTE 15 & 16)

TOTAL NUMBER OF POSITION
FROM 1 THRU 36 POS. (SEE NOTE 3)

PIN PLATING (SEE NOTE 13)
1=0.76µm Au
4= PURE TIN
8=0.36µm Au

BASE PART NO.

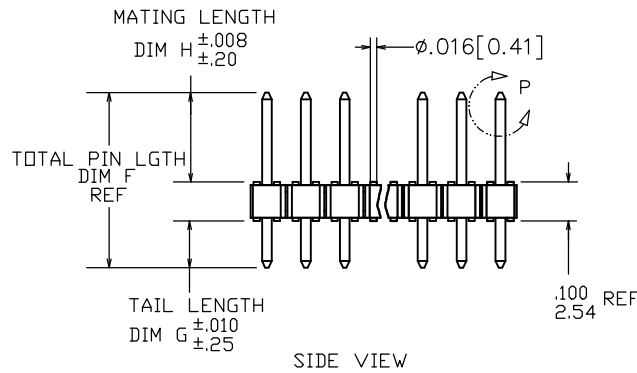

NOTE 6

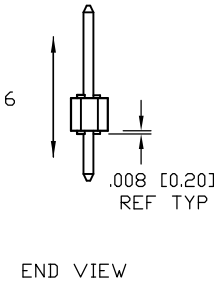

$\phi .020 / .51$ (M) (U) (M) (V) (S)

NOTE 4

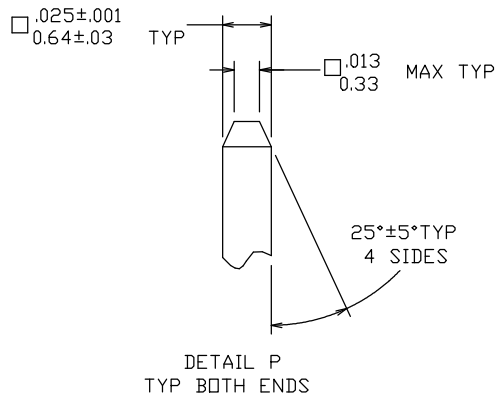

USER DIRECTION

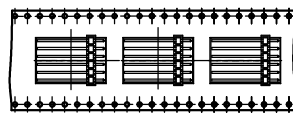

PACKAGE:

ONLY FOR 68000-406160035ALF

mat'l. code NOTES 2 & 3		surface ISO 1302 ✓		tolerance ISO 406 ISO 1101		projection 		product family BERGSTIK	
ltr	ec'n no	dr	date	tolerances unless otherwise specified		INCH/MM		title BERGSTIK® II HEADER	
CY	ELX-N-01895	JZ	2012-06-12	angles	.XX±01/.X±.3	scale 1:1		.100/2.54cc SR STRAIGHT	
DA	ELX-N-16105	ZK	2013-10-22	linear	.XXX±0.006/.XX±.15			dwg no	
DB	ELX-N-17329	ZK	2014-03-27	0°±2'	.XXX±0.0002/.XXX±.005			sheet 1 of 8	
DC	ELX-N-28578	MZ	2017-11-23	dr	T.BREWBAKER	01/05/95		size A3	
DD	ELX-N-35840	MZ	2020-01-08	engr	T.HANNA	01/05/95		68000	
DE	ELX-N-38872	MX	2020-11-04	chr	J.MURPHY	01/05/95		type Product Customer Drawing	
DF	ELX-N-39694	MX	2020-12-17	appd	T.HANNA	01/05/95			
sheet	revision	DF	DF	DF	DF	DF	DF	DF	DF
index	sheet	1	2	3	4	5	6	7	8

Amphenol FCI

© 2016 AFCI

PIN PLATING CODES:

XXXX-1YY	30u"/0.76u MIN (SEE NOTE 13) OVER 50u"/1.27u MIN Ni
XXXX-2YY	15u"/0.38u MIN (SEE NOTE 13) OVER 50u"/1.27u MIN Ni
XXXX-3YY	50u"/1.27u MIN (SEE NOTE 13) OVER 50u"/1.27u MIN Ni
XXXX-4YY	100u"/2.54u MIN Sn OVER 50u"/1.27u MIN Ni (SEE NOTE 14)
XXXX-4YYHLF	
XXXX-5YY	15u"/0.38u MIN (SEE NOTE 13) OVER 50u"/1.27u MIN Ni
XXXX-6YY	30u"/0.76u MIN (SEE NOTE 13) OVER 50u"/1.27u MIN Ni
XXXX-7YY	30u"/0.76u MIN (SEE NOTE 13) OVER 50u"/1.27u MIN Ni
XXXX-8YY	15u"/0.38u MIN (SEE NOTE 13) OVER 50u"/1.27u MIN Ni
XXXX-9YY	15u"/0.38u MIN (SEE NOTE 13) OVER 50u"/1.27u MIN Ni
XXXX-0YY	30u"/0.76u MIN (SEE NOTE 13) OVER 50u"/1.27u MIN Ni

NOTES

1. PART NUMBER OPTIONS:

PIN PLATING CODES (SEE ABOVE)

HIGH TEMP. MATERIAL:

PART NUMBERS WITH AND WITHOUT "H" WILL BE SUPPLIED WITH HIGH TEMPERATURE PLASTIC

NUMBER OF POSITIONS :

ANY NUMBER OF POSITIONS FROM 1 THRU 36. -X00H INDICATES BERGSTRIIP PRODUCT. SEE PAGE 3 FOR SPECIAL GEOMETRY OF THIS CONTINUOUS STRIP PRODUCT. AUTOMATED REELS WILL CONTAIN 36,000 PINS. SEE SPECIFIC PART NUMBERS FOR AVAILABILITY.

PACKAGING :

- NONE =POLY BAGS WITHOUT PICK UP CAP
 - T =PACKAGED IN TUBES
 - C =PACKAGED IN TUBE WITH PICK UP CAP
 - A =PACKAGED IN TAPE AND REEL WITH PICK UP CAP
 - D =PACKAGED IN TAPE AND REEL WITHOUT PICK UP CAP
 - E =PACKAGED IN TAPE AND REEL WITH NARROW PICK UP CAP
- BERGSTRIIP™ PART NUMBERS FOLLOWED BY A "B" ARE BULK PRICED.

LEAD FREE :

ADD "LF" SUFFIX AT THE END OF PART NUMBER FOR LEAD FREE

ADDITIONAL CODE :

- NONE = GENERAL TAIL LENGTH AND MATING LENGTH
- R = REVERSE THE TAIL LENGTH AND MATING LENGTH

2. BODY MATERIAL :

BERGSTIK: MANUFACTURER'S OPTION OF NYLON, PCT GLASS FIBER REINFORCED, OR LCP MINERAL FILLED FLAME RETARDANT PER UL-94V-0.

COLOR : BLACK

BERGSTRIIP™ PRODUCED WITH HIGH TEMPERATURE LCP THERMOPLASTIC, FLAME RETARDANT PER UL-94V-0. COLOR : BLACK

PART NUMBERS WITH AND WITHOUT "H" SUFFIX WILL WITHSTAND EXPOSURE TO 260°C PEAK TEMPERATURE FOR 20 SECONDS IN WAVE SOLDER, INFRA-RED DR VAPOR PHASE SOLDER PROCESS.

3. PIN MATERIAL : PHOS-BRONZE.

4. MEASURED WITH PART IN RESTRAINED CONDITION.

5. TWO SIDES OF PIN TIPS NOT PLATED. TYPICAL BOTH ENDS.

6. 2LBS/0.9KG MIN PIN RETENTION IN EITHER DIRECTION.

7. PIN CANNOT PROTRUDE PAST EDGE OF HOUSING. MUST BE .005±.005/.13±.13 FROM END OF HOUSING HOLE.

8. MILITARY BERGSTIK HEADER
P/N XXXXX-YYY-MIL.
NOT AVAILABLE.

9. ±.010/0.25 TOL APPLIES TO ALL "G" TAILS EXCEPT INDICATED PARTS ON TABLE WHERE +.010/0.25 -.000/0.00 APPLIES.

10. INDICATED PART NUMBERS ARE PRODUCED AND SOLD IN THE TAIWAN/SINGAPORE AREAS. THESE ARE NOT AVAILABLE IN BERGSTRIIP™ CONTINUOUS STRIP.

11. NOTCH CONFIGURATION WILL VARY PER VENDOR'S DISCRETION.

12. THESE PRODUCTS MEETS EUROPEAN UNION DIRECTIVES AND OTHER COUNTRY REGULATION AS DESCRIBED IN GS-22-008.

13. PLATING OPTIONS:
PERFORMANCE PLATING WILL BE EITHER GOLD OR GXT ON POST OR TAIL, OPTIONALLY (78~295u"/2~7.5u) TIN ON TAIL.

14. *THIS PRODUCT HAS 100% TIN PLATING IN THE INTERFACE AND HAS NOT BEEN TESTED FOR WHISKER GROWTH IN ALL INTERCONNECT ENVIRONMENTS.*

15. THE TOTAL PIN LGTH DON'T EXCEED 34.5mm

16. INCREMENTS BY 0.1mm IN LENGTHS ONLY

17. THE TOTAL PIN LGTH <10mm DR >37mm PRODUCT HAS TIN PLATING DR GOLD PLATING OVER ALL. THE OTHERS HAS GOLD DR TIN PLATING ON CONTACT AREA AND TIN PLATING ON TAIL.

18. FOR SPECIAL PACKAGING REQUEST PLEASE CONTACT PRODUCT MANAGER FOR AVAILABILITY

19. TO DETERMINE DIMENSIONS:
N=NUMBER OF POSITION PER ROW
EXAMPLE: 10 PDS. N X .100/2.54, REFERENCE DIMENSION

20. 68000-406160035ALF IS SPECIAL PART NUMBER, IT IS 6PIN, MATING LENGTH IS 16mm. TAIL LENGTH IS 3.5mm. AND PACKAGE IS TAPE AND REEL AND NO CAP.

mat'l. code		surface	tolerance	projection	product family			
NOTES 2 & 3		ISD 1302 ✓	ISD 406 ISD 1101		BERGSTIK			
ltr	ecn no	dr	date	tolerances unless otherwise specified		title		
DF				angles	.XX±01/.X±3	BERGSTIK® II HEADER		
				linear	.XXX±0.006/.XX±.15	.100/2.54cc SR STRAIGHT		
				0±2'	.XXX±0.0002/.XXX±.005	scale 1:1		
		dr	T.BREWBAKER	01/05/95		dwg no	sheet 2 of 8	size
		enr	T.HANNA	01/05/95		68000	A3	
		chr	J.MURPHY	01/05/95		type Product Customer Drawing		
		appd	T.HANNA	01/05/95				
sheet index	revision sheet							

Amphenol FCI

© 2016 AFCI

BERGSTRIPTM HEADER

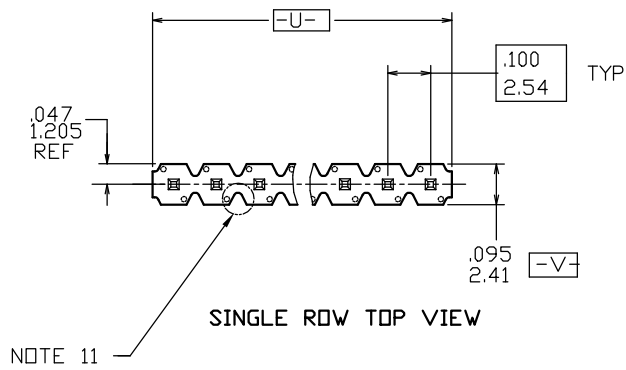

REEL PACKING DIMENSIONS

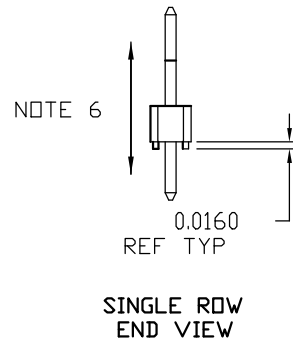
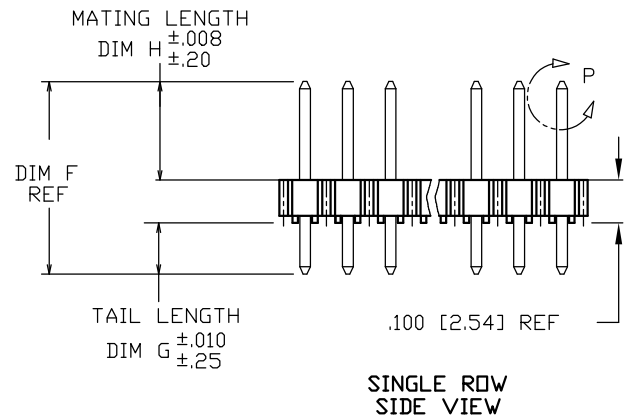
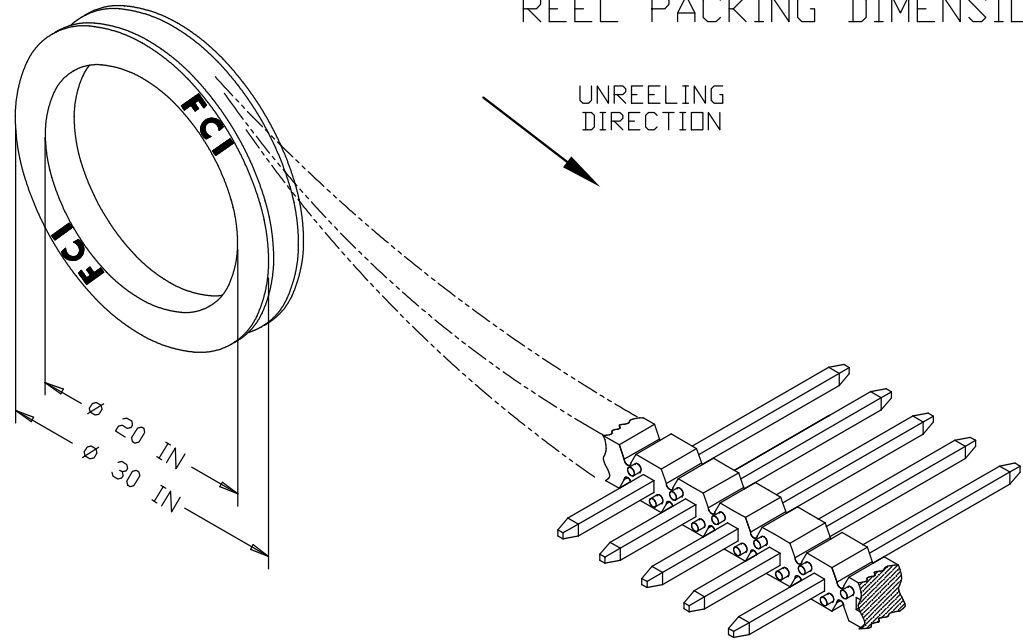

mat'l. code NOTES 2 & 3		surface ISO 1302 ✓	tolerance ISO 406 ISO 1101	projection 	product family BERGSTIK
ltr	ecn no	dr	date	tolerances unless otherwise specified	title BERGSTIK® II HEADER .100/2.54cc SR STRAIGHT
DF				angles linear 0°±2'	INCH/MM scale 1:1
		dr	T.BREWBAKER	01/05/95	dwg no 68000
		enr	T.HANNA	01/05/95	sheet 3 of 8 A3
		chr	J.MURPHY	01/05/95	Amphenol FCI
		appd	T.HANNA	01/05/95	type Product Customer Drawing
sheet index	revision sheet				

Amphenol FCI
© 2016 AFCI

PRODUCT NUMBER	TOTAL PIN LGTH		TAIL LENGTH		MATING LENGTH		PACKAGING	NOTES	BERGSTIP™ AVAILABLE	LF OPTION
	DIM F	DIM F	DIM G	DIM G	DIM H	DIM H				
	ENGLISH	METRIC	ENGLISH	METRIC	ENGLISH	METRIC				
55492-XYH	0.315	8.00	0.095	2.41	0.120	3.05	POLY BAGS	-	NO	QB
60017-XYH	0.620	15.75	0.210	5.33	0.310	7.87	POLY BAGS	-	NO	QB
60018-XYH	0.660	16.76	0.250	6.35	0.310	7.87	POLY BAGS	-	NO	QB
63334-XYH	0.435	11.05	0.095	2.41	0.240	6.10	POLY BAGS	-	NO	QB
68000-XY	0.425	10.80	0.095	2.41	0.230	5.84	POLY BAGS	-	YES	NOTE 1,12
68001-XY	0.450	11.43	0.120	3.05	0.230	5.84	POLY BAGS/TUBES	-	YES	
68002-XY	0.480	12.19	0.150	3.81	0.230	5.84	POLY BAGS	-	YES	
68003-XY	0.525	13.34	0.195	4.95	0.230	5.84	POLY BAGS	-	NO	QB
68004-XY	0.525	13.34	0.107	2.72	0.318	8.08	POLY BAGS	-	YES	
68024-XY	0.568	14.43	0.150	3.81	0.318	8.08	POLY BAGS	-	YES	
68031-XY	0.513	13.03	0.183	4.65	0.230	5.84	POLY BAGS	-	NO	
68032-XY	0.543	13.79	0.213	5.41	0.230	5.84	POLY BAGS	-	NO	QB
68033-XY	0.708	17.98	0.473	12.01	0.135	3.43	POLY BAGS	-	NO	
68415-XY	0.615	15.62	0.115	2.92	0.400	10.16	POLY BAGS	-	NO	
68416-XY	0.813	20.65	0.483	12.27	0.230	5.84	POLY BAGS	-	NO	
68418-XY	0.730	18.54	0.400	10.16	0.230	5.84	POLY BAGS	-	NO	
68422-XY	0.631	16.03	0.213	5.41	0.318	8.08	POLY BAGS	-	NO	
68443-XY	0.755	19.18	0.425	10.80	0.230	5.84	POLY BAGS	-	NO	QB
68456-XY	0.825	20.96	0.115	2.92	0.610	15.49	POLY BAGS	-	NO	QB
68457-XY	0.548	13.92	0.130	3.30	0.318	8.08	POLY BAGS	-	NO	
68465-XY	0.925	23.50	0.595	15.11	0.230	5.84	POLY BAGS	-	NO	QB
68466-XY	0.925	23.50	0.128	3.25	0.697	17.70	POLY BAGS	-	NO	
68472-XY	0.913	23.19	0.413	10.49	0.400	10.16	POLY BAGS	-	NO	QB
68479-XY	0.718	18.24	0.388	9.86	0.230	5.84	POLY BAGS	-	NO	QB
68483-XY	0.835	21.21	0.417	10.59	0.318	8.08	POLY BAGS	-	NO	QB
68487-XY	0.705	17.91	0.110	2.79	0.495	12.57	POLY BAGS	-	NO	QB
68489-XY	1.095	27.81	0.765	19.43	0.230	5.84	POLY BAGS	-	NO	QB
68490-XY	1.025	26.04	0.695	17.65	0.230	5.84	POLY BAGS	-	NO	QB
68497-XY	0.612	15.54	0.085	2.16	0.427	10.85	POLY BAGS	-	NO	
68603-XY	0.555	14.10	0.120	3.05	0.335	8.51	POLY BAGS	-	NO	
68604-XY	0.600	15.24	0.120	3.05	0.380	9.65	POLY BAGS	-	NO	NOTE 1,12

A

B

C

Amphenol FCI

© 2016 AFCI

mat'l. code NOTES 2 & 3		surface ISD 1302 ✓	tolerance ISB 406 ISD 1101	projection 	product family BERGSTIK
ltr	ecn no	dr	date	tolerances unless otherwise specified	title BERGSTIK® II HEADER .100/2.54cc SR STRAIGHT
DF				angles linear .XX±01/.X±.3 .XXX±0.006/.XX±.15 .XXX±0.0002/.XXX±.005	
				0±2'	scale 1:1
		dr	T.BREWBAKER	01/05/95	Amphenol FCI dwg no 68000 sheet 4 of 8 size A3
		enr	T.HANNA	01/05/95	
		chr	J.MURPHY	01/05/95	
		appd	T.HANNA	01/05/95	type Product Customer Drawing
sheet index	revision sheet				

PRODUCT NUMBER	TOTAL PIN LGTH		TAIL LENGTH		MATING LENGTH		BERGSTRIPTM		LF OPTION	
	DIM F	DIM F	DIM G	DIM G	DIM H	DIM H	AVAILABLE			
	ENGLISH	METRIC	ENGLISH	METRIC	ENGLISH	METRIC	PACKAGING	NOTES		
68629 -XXX	0.621	15.77	0.203	5.16	0.318	8.08	POLY BAGS	-	NO	OB
68630 -XXX	0.603	15.32	0.273	6.93	0.230	5.84	POLY BAGS	-	NO	OB
68631 -XXX	0.703	17.86	0.203	5.16	0.400	10.16	POLY BAGS	-	NO	OB
68632 -XXX	0.743	18.87	0.413	10.49	0.230	5.84	POLY BAGS	-	NO	OB
68633-XXX	0.643	16.33	0.225	5.72	0.318	8.08	POLY BAGS	-	NO	NOTE 1,12
68634 -XXX	1.013	25.73	0.683	17.35	0.230	5.84	POLY BAGS	-	NO	OB
68642 -XXX	0.913	23.19	0.583	14.81	0.230	5.84	POLY BAGS	-	NO	OB
68652 -XXX	1.470	37.34	0.670	17.02	0.700	17.78	POLY BAGS	-	NO	OB
68653-XXX	0.735	18.67	0.095	2.41	0.540	13.72	POLY BAGS	-	NO	
68654 -XXX	1.050	26.67	0.670	17.02	0.280	7.11	POLY BAGS	-	NO	OB
68655-XXX	0.708	17.98	0.290	7.37	0.318	8.08	POLY BAGS	-	NO	
68656 -XXX	1.113	28.27	0.613	15.57	0.400	10.16	POLY BAGS	-	NO	OB
68657 -XXX	0.588	14.94	0.368	9.35	0.120	3.05	POLY BAGS	-	NO	
68658 -XXX	0.820	20.83	0.130	3.30	0.590	14.99	POLY BAGS	-	NO	OB
68659 -XXX	0.608	15.44	0.398	10.11	0.110	2.79	POLY BAGS	-	NO	OB
68686 -XXX	1.016	25.81	0.458	11.63	0.458	11.63	POLY BAGS	-	NO	OB
68689 -XXX	0.913	23.19	0.213	5.41	0.600	15.24	POLY BAGS	-	NO	OB
68705-XXX	0.395	10.03	0.095	2.41	0.200	5.08	POLY BAGS	-	NO	
68717-XXX	0.615	15.62	0.285	7.24	0.230	5.84	POLY BAGS	-	NO	
68730 -XXX	0.555	14.10	0.225	5.72	0.230	5.84	POLY BAGS	-	NO	OB
68731 -XXX	0.880	22.35	0.440	11.18	0.340	8.64	POLY BAGS	-	NO	OB
68735 -XXX	1.016	25.81	0.520	13.21	0.396	10.06	POLY BAGS	-	NO	OB
68755 -XXX	1.166	29.62	0.533	13.54	0.533	13.54	POLY BAGS	-	NO	OB
68760 -XXX	0.803	20.40	0.353	8.97	0.350	8.89	POLY BAGS	-	NO	OB
68762 -XXX	0.588	14.94	0.213	5.41	0.275	6.99	POLY BAGS	-	NO	OB
68771-XXX	0.470	11.94	0.100	2.54	0.270	6.86	POLY BAGS	-	NO	NOTE 1,12
68781 -XXX	0.691	17.55	0.273	6.93	0.318	8.08	POLY BAGS	-	NO	OB

Amphenol FCI

© 2016 AFCl

mat'l. code NOTES 2 & 3		surface ISD 1302 ✓	tolerance ISD 406 ISD 1101	projection 	product family BERGSTIK
ltr	ecn no	dr	date	tolerances unless otherwise specified	title BERGSTIK® II HEADER .100/2.54cc SR STRAIGHT
DF				angles linear .XX±01/.X±.3 .XXX±0.006/.XX±.15 .XXX±0.0002/.XXX±.005	
				0±2'	
		dr	T.BREWBAKER	01/05/95	dwg no 68000 sheet 5 of 8 size A3
		enr	T.HANNA	01/05/95	
		chr	J.MURPHY	01/05/95	
		appd	T.HANNA	01/05/95	type Product Customer Drawing
sheet index	revision sheet				

PRODUCT NUMBER	TOTAL PIN LGTH		TAIL LENGTH		MATING LENGTH		BERGSTRIPTM		LF OPTION	
	DIM F	DIM F	DIM G	DIM G	DIM H	DIM H	AVAILABLE			
	ENGLISH	METRIC	ENGLISH	METRIC	ENGLISH	METRIC	PACKAGING	NOTES		
68795-XXX	0.500	12.70	0.062	1.57	0.338	8.59	POLY BAGS	-	NO	OB
68796-XXX	0.633	16.08	0.423	10.74	0.110	2.79	POLY BAGS	-	NO	OB
68797-XXX	0.413	10.49	0.213	5.41	0.100	2.54	PE BAG/TAPE&REEL	-	NO	NOTE 1,12
68797-XXYR	0.413	10.49	0.100	2.54	0.213	5.41	PE BAG/TAPE&REEL	-	NO	NOTE 1,12
69148-XXX	0.442	11.43	0.000	0.00	0.350	8.89	POLY BAGS	-	NO	OB
69152-XXX	0.720	18.29	0.120	3.05	0.500	12.70	POLY BAGS/TUBES	-	NO	OB
69173-XXX	0.530	13.46	0.135	3.43	0.295	7.49	POLY BAGS	-	NO	
69188-XXX	0.751	19.08	0.333	8.46	0.318	8.08	POLY BAGS	-	NO	
69751-XXX	0.440	11.18	0.170	4.32	0.170	4.32	POLY BAGS	NOTE 10	NO	OB
71417-XXX	0.664	16.87	0.115	2.92	0.449	11.40	POLY BAGS	NOTE 10	NO	OB
72260-XYXH	0.930	23.62	0.090	2.29	0.740	18.80	POLY BAGS	-	NO	OB
72323-XYXH	1.200	30.48	0.100	2.54	1.000	25.40	POLY BAGS	-	NO	OB
72457-XYXH	1.100	27.94	0.090	2.29	0.910	23.11	POLY BAGS	-	NO	OB
73698-XYXH	1.100	27.94	0.120	3.05	0.880	22.35	POLY BAGS	-	NO	
74464-XYXH	1.028	26.11	0.610	15.49	0.318	8.08	POLY BAGS	-	NO	OB
78240-XXX	0.663	16.84	0.333	8.46	0.230	5.84	POLY BAGS	-	NO	OB
78287-XXX	0.678	17.22	0.120	3.05	0.458	11.63	POLY BAGS	-	NO	OB
78290-XXX	1.250	31.75	0.500	12.70	0.650	16.51	POLY BAGS	-	NO	
78511-XXX	0.538	13.67	0.120	3.05	0.318	8.08	POLY BAGS/TUBES	-	YES	
78595-XXX			NOT AVAILABLE					-	-	
78931-XXX			NOT AVAILABLE					-	-	
78958-XXX			NOT AVAILABLE					-	-	
78959-XXX			NOT AVAILABLE					-	-	
78977-XXX			NOT AVAILABLE					-	-	
78998-XXX	0.430	10.92	0.155	3.94	0.175	4.45	POLY BAGS	-	NO	
78999-XXX			NOT AVAILABLE					-	-	NOTE 1,12
79428-XXX	0.695	17.65	0.120	3.05	0.475	12.07	POLY BAGS	-	NO	OB
79849-XXX	0.620	15.75	0.120	3.05	0.400	10.16	POLY BAGS	-	NO	OB

Amphenol FCI
© 2016 AFCI

mat'l. code NOTES 2 & 3		surface ISO 1302 ✓	tolerance ISO 406 ISO 1101	projection 	product family BERGSTIK
ltr	ecn no	dr	date	tolerances unless otherwise specified	title BERGSTIK® II HEADER .100/2.54cc SR STRAIGHT
DF				angles linear .XX±01/.X±3 .XXX±0.006/.XX±.15 .XXX±0.0002/.XXX±.005	
				0±2'	INCH/MM scale 1:1
		dr	T.BREWBAKER	01/05/95	Amphenol FCI dwg no 68000 sheet 6 of 8 size A3
		enr	T.HANNA	01/05/95	
		chr	J.MURPHY	01/05/95	
		appd	T.HANNA	01/05/95	type Product Customer Drawing
sheet index	revision sheet				

PRODUCT NUMBER	TOTAL PIN LGTH		TAIL LENGTH		MATING LENGTH		BERGSTRIPTM		LF OPTION	
	DIM F	DIM F	DIM G	DIM G	DIM H	DIM H	AVAILABLE			
	ENGLISH	METRIC	ENGLISH	METRIC	ENGLISH	METRIC	PACKAGING	NOTES		
84918-XYH	0.340	8.64	0.120	3.05	0.120	3.05	POLY BAGS	-	YES	OB
84921-XYH	0.370	9.40	0.150	3.81	0.120	3.05	POLY BAGS	-	YES	OB
86506-XY	0.440	11.18	0.120	3.05	0.220	5.59	POLY BAGS	-	YES	OB
86579-XY	0.450	11.43	0.120	3.05	0.230	5.84	POLY BAGS	NOTE 9	NO	OB
86634-XY		NOT AVAILABLE						-	-	NOTE 1,12
86635-XY		NOT AVAILABLE						-	-	
86636-XY		NOT AVAILABLE						-	-	
86637-XY		NOT AVAILABLE						-	-	
86638-XY		NOT AVAILABLE						-	-	
86793-XY	0.900	22.86	0.100	2.54	0.700	17.78	POLY BAGS	NOTE 10	NO	OB
86899-XY	1.020	25.91	0.120	3.05	0.800	20.32	POLY BAGS	-	NO	OB
87185-XY	1.238	31.45	0.095	2.41	1.043	26.49	POLY BAGS	NOTE 10	NO	
87204-XY	0.895	22.73	0.120	3.05	0.675	17.15	POLY BAGS	-	NO	OB
87241-XY	1.000	25.40	0.120	3.05	0.780	19.81	POLY BAGS	-	NO	OB
87502-XYH	1.130	28.70	0.110	2.79	0.920	23.37	POLY BAGS	-	NO	OB
87827-XY	0.380	9.65	0.120	3.05	0.160	4.06	POLY BAGS	-	NO	
87916-XY	1.058	26.87	0.128	3.25	0.830	21.08	POLY BAGS	-	NO	NOTE 1,12
88005-XY	0.536	13.61	0.095	2.41	0.341	8.66	POLY BAGS	NOTE 10	NO	OB
88706-XY	0.900	22.86	0.100	2.54	0.700	17.78	POLY BAGS	-	NO	OB
89232-XY	0.325	8.26	0.000	0.00	0.230	5.84	POLY BAGS	NOTE 7	NO	OB

A
 B
 C
 D



© 2016 AFCI

mat'l. code NOTES 2 & 3		surface ISO 1302 ✓	tolerance ISO 406 ISO 1101	projection 	product family BERGSTIK
ltr	ecn no	dr	date	tolerances unless otherwise specified	title BERGSTIK® II HEADER .100/2.54cc SR STRAIGHT
DF				angles linear .XX±01/.X±3 .XXX±0.006/.XX±15 .XXX±0.0002/.XXX±.005	
				0±2'	scale 1:1
		dr	T.BREWBAKER	01/05/95	Amphenol FCI dwg no 68000 sheet 7 of 8 size A3
		enr	T.HANNA	01/05/95	
		chr	J.MURPHY	01/05/95	
		appd	T.HANNA	01/05/95	type Product Customer Drawing
sheet index	revision sheet				

D

PRODUCT NUMBER	TOTAL PIN LGTH		TAIL LENGTH		MATING LENGTH		PACKAGING	NOTES	BERGSTRIIP AVAILABLE	LF OPTION
	DIM F	DIM F	DIM G	DIM G	DIM H	DIM H				
	ENGLISH	METRIC	ENGLISH	METRIC	ENGLISH	METRIC				
90522-XXX	0.668	16.97	0.135	3.43	0.433	11.00	POLY BAGS	NOTE 10	NO	OB
90547-XXX	0.508	12.90	0.095	2.41	0.313	7.95	POLY BAGS	NOTE 10	NO	OB
90719-XXX	0.384	9.75	0.106	2.69	0.178	4.52	POLY BAGS	-	NO	
90726-XXX	0.440	11.18	0.110	2.79	0.230	5.84	POLY BAGS	-	YES	OB
91276-XXX	1.225	31.12	0.225	5.72	0.900	22.86	POLY BAGS	-	NO	NOTE 1,12
92020-XXX	0.372	9.45	0.094	2.39	0.178	4.52	POLY BAGS	-	NO	OB
A 92418-XXX	0.572	14.53	0.118	3.00	0.354	8.99	POLY BAGS	-	NO	OB
93167-XXX	0.394	10.01	0.059	1.50	0.235	5.97	POLY BAGS	-	NO	OB
93287-XXYH	0.585	14.86	0.085	2.16	0.400	10.16	POLY BAGS	-	NO	
93944-XXX	0.941	23.90	0.130	3.30	0.711	18.06	POLY BAGS	-	NO	
93992-XXYH	0.415	10.54	0.085	2.16	0.230	5.84	POLY BAGS	-	NO	
94063-XXX	0.376	9.55	0.138	3.51	0.138	3.51	POLY BAGS	NOTE 10	NO	
94094-XXX	0.592	15.04	0.314	7.98	0.178	4.52	POLY BAGS	-	NO	OB
94544-XXX	0.550	13.97	0.130	3.30	0.330	8.38	POLY BAGS	NOTE 10	NO	OB
94611-XXYH	0.320	8.13	0.095	2.41	0.125	3.18	POLY BAGS	-	NO	
95017-XXYH	0.560	14.22	0.060	1.52	0.400	10.16	POLY BAGS	-	NO	OB
B 95103-XXX	1.064	27.03	0.433	11.00	0.531	13.49	POLY BAGS	NOTE 10	NO	OB
95104-XXX	0.370	9.40	0.126	3.20	0.144	3.66	POLY BAGS	NOTE 10	NO	OB
95648-XXYH	0.655	16.64	0.155	3.94	0.400	10.16	POLY BAGS	-	NO	OB
95655-XXX	1.164	29.57	0.095	2.41	0.969	24.61	POLY BAGS	NOTE 10	NO	OB
98001-XXYH	0.610	15.49	0.420	10.67	0.090	2.29	POLY BAGS	-	NO	OB
98136-XXYH	0.475	12.07	0.095	2.41	0.280	7.11	POLY BAGS	-	NO	OB
10004394-XXYH	0.290	7.37	0.095	2.41	0.095	2.41	POLY BAGS	-	NO	OB
10076764-XXYH	0.479	12.19	0.114	2.9	0.265	6.75	POLY BAGS	-	YES	OB
10103017-XXX	0.335	8.51	0.130	3.30	0.105	2.67	POLY BAGS	-	NO	OB
C 10121349-XXX	0.626	15.9	0.120	3.05	0.406	10.3	POLY BAGS/TAPE REEL	-	NO	NOTE 1,12

Amphenol FCI

© 2016 AFCI

mat'l. code NOTES 2 & 3		surface ISD 1302 ✓	tolerance ISD 406 ISD 1101	projection 	product family BERGSTIK
ltr	ecn no	dr	date	tolerances unless otherwise specified	title BERGSTIK® II HEADER
DF				angles linear .XX±01/.X±3 .XXX±0.006/.XX±15 .XXX±0.0002/.XXX±.005	.100/2.54cc SR STRAIGHT
				0±2'	scale 1:1
		dr	T.BREWBAKER	01/05/95	dwg no 68000
		enr	T.HANNA	01/05/95	sheet 8 of 8
		chr	J.MURPHY	01/05/95	size A3
		appd	T.HANNA	01/05/95	type Product Customer Drawing
sheet index	revision sheet				

X-ON Electronics

Largest Supplier of Electrical and Electronic Components

Click to view similar products for [Headers & Wire Housings](#) category:

Click to view products by [Amphenol](#) manufacturer:

Other Similar products are found below :

[892-18-020-10-001101](#) [58102-G61-06LF](#) [582553-1](#) [0009485154](#) [009176003701906](#) [0050291907](#) [LY20-4P-DT1-P1E-BR](#) [02.125.8002.8](#)
[609-3404](#) [61062-3](#) [622-0430](#) [622-3653LF](#) [63453-116](#) [636-1030](#) [636-1427](#) [636-3427](#) [636-4007](#) [641938-9](#) [641991-4](#) [644827-2](#) [65817-010LF](#)
[65817-015LF](#) [65863-015LF](#) [66207-023LF](#) [67095-007LF](#) [67601157](#) [68648-049](#) [70.362.1628.0](#) [70-4210](#) [70-4226B](#) [70-4853B](#) [707-5020](#) [707-](#)
[5028](#) [71.350.2428.0](#) [71918-208LF](#) [71961-016LF](#) [733-134](#) [733-162](#) [754199-000](#) [760-3052](#) [787-8014-00](#) [79531-3000](#) [FCN-360C032-B](#) [FCN-](#)
[367T-T012/H](#) [FCN-723D010/2](#) [80.063.4001.1](#) [800-90-001-10-001000](#) [800-90-010-10-002000](#) [801-43-002-10-013000](#) [801-43-006-10-002000](#)