

# D-SUBMINIATURE CONNECTORS

AMPHENOL® DIN 41612 TWO-PIECE  
PRINTED CIRCUIT BOARD CONNECTORS  
SHORT FORM CATALOG

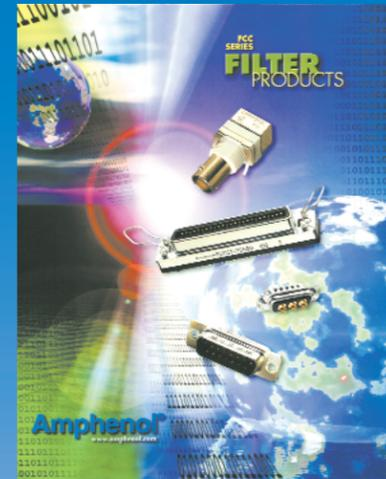

**DIN 41612  
Circuit Board Connectors**



**FCC Filtered  
Connectors**



**RJ Modular  
Jacks**

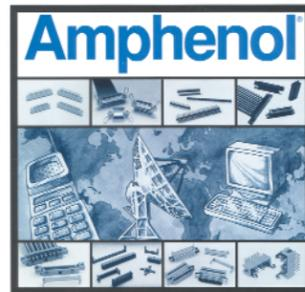

HEADERS & SOCKETS  
AND  
MASS-TERMINATED  
IDC CONNECTORS

**IDC  
Connectors**

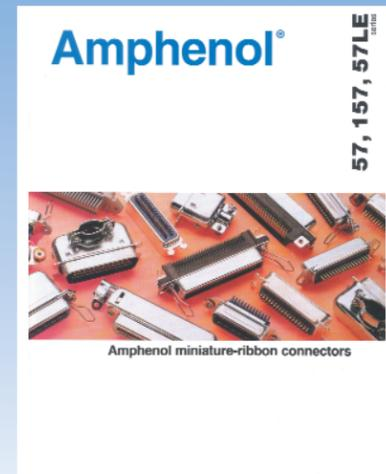

**Miniature  
Ribbon Connectors**

# Amphenol®

*Data / Telecom Products*

20 Melford Drive  
Scarborough, Ontario  
Canada M1B 2X6

Telephone: (416) 754-5656  
Facsimile: (416) 754-8668  
Email: sales@amphenolcanada.com  
Website: www.amphenolcanada.com

© Amphenol Canada Corp.  
Specifications subject to change without notice.  
Designed by K Jasper Marketing Communications Inc.

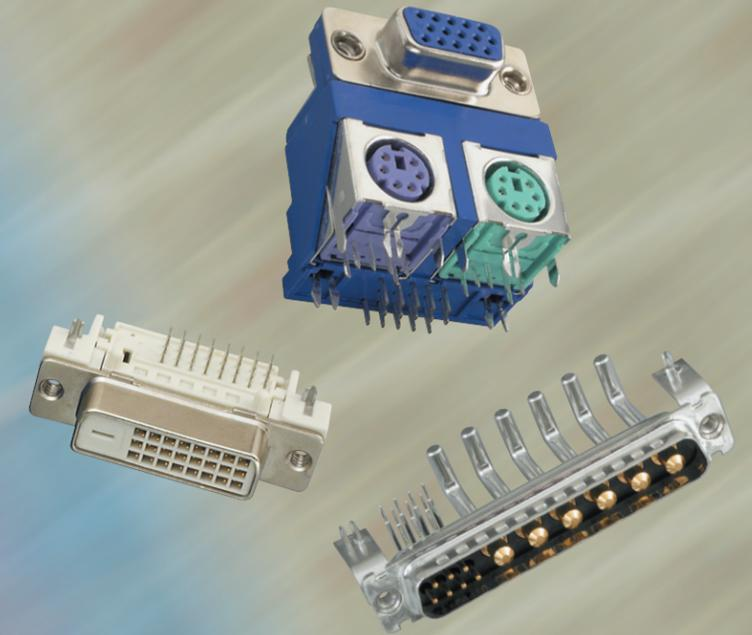

# Amphenol®

ACCESSORIES

STANDARD DENSITY

SURFACE MOUNT RECEPTACLES

HIGH DENSITY

#### GENERAL DESCRIPTION:

---

Amphenol's line of D-Subminiature rack and panel connectors is part of an industry standard for applications requiring reliable, rugged, connectors. These connectors are designed to accommodate rack and panel, cable to panel and cable to cable applications. D-Subminiature connectors are pin and socket devices that employ contacts encased in a molded dielectric insert surrounded by a "D" shaped shell for polarization.

#### MARKETS:

---

Amphenol D-Subminiature connectors can be used in commercial, industrial or military markets. We offer a broad selection of dielectric materials and contact styles and configurations to meet all of your design requirements.

#### APPLICATIONS INCLUDE:

---

- Business equipment
- Electronic office systems
- Data communications
- Medical equipment
- Mobile communications
- Consumer electronics

#### AMPHENOL D-SUB FEATURES:

---

- Industry standard interfacing RS232 and RS449 mating configurations per EIA standards.
- UL Component Recognition File number E64911 (617, 841, 17, 17D, 17HD, ED, 17RR, 17SD, 117DF, 17BH, 17TW)
- Variations available:
  - Solder cup
  - Straight pc mount solder
  - Right angle pc mount solder
  - Solderless wire wrap
  - Crimp
  - High Density Right Angle
  - High Density Straight
  - Stacked Right Angle PC mount
  - Surface mount
- Five shell sizes offer widest choice of contact positions: 9, 15, 25, 37 and 50 in standard density and 15, 26, 44, 62 and 78 positions in high-density.
- Inserts are flame-retardant thermoplastic.
- Accessories for all applications are available including strain reliefs, cable clamps, shielded backshells, mating hardware and connector to pc board mounting hardware.
- Automatic and manual tooling is available for both crimp and IDC versions.
- Contact Amphenol for lease information.

High Density

SPECIFICATIONS:

MATERIALS AND PLATINGS

Shells	Steel, tin plated, grounding indents on plug.
Contact Material	Copper alloy
Contact Plating	Engagement area: gold (see ordering information).
Termination End	150µ" (3.81µm) tin/lead
Nickel Underplate	50µ" (1.27µm) entire contact

ELECTRICAL DATA

Current Rating	3 Amps maximum per contact
Voltage Rating	125 VAC
Dielectric Withstanding Voltage	1000 VAC (minimum)
Dielectric	Glass filled thermoplastic, black, UL 94 VO
Insulation Resistance	5,000 Megaohms (minimum)
Contact Resistance	15 Milliohms (maximum)

CLIMATIC DATA

Operating Temperature	-67°F (-55°C) to 221°F (105°C)
-----------------------	--------------------------------

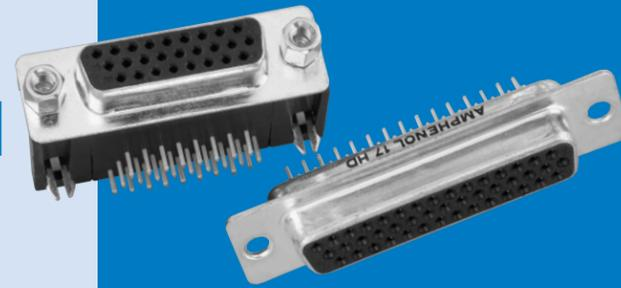

17E BH/HD SERIES

Amphenol's High Density D-Subminiature connectors complement Amphenol's extensive D-Subminiature connector line. This line of connectors offers many superior features, high performance level and low installation cost.

The connector configurations are available in 15, 26, 44, 62 and 78 positions.

The product offering includes PCB mount connectors in both straight or right angle termination styles. Straight PCB mount are available in both Fixed Screw Machine and Stamped and Formed contacts, while Right Angle PCB mount are only available with Stamped and Formed contacts.

A cable mount version with solder terminations is also available, which can be combined with Amphenol's standard line of shielded or unshielded backshells.

- Industrial
- Telecom
- Any industry standard I / O connections

INCHES (MM)

DIMENSIONS FOR 15 - 62 POSITION (3 ROW)(SHOWN WITH FIXED FEMALE SCREWLOCKS) DIMENSIONS FOR THE 78 POSITION (4 ROW)

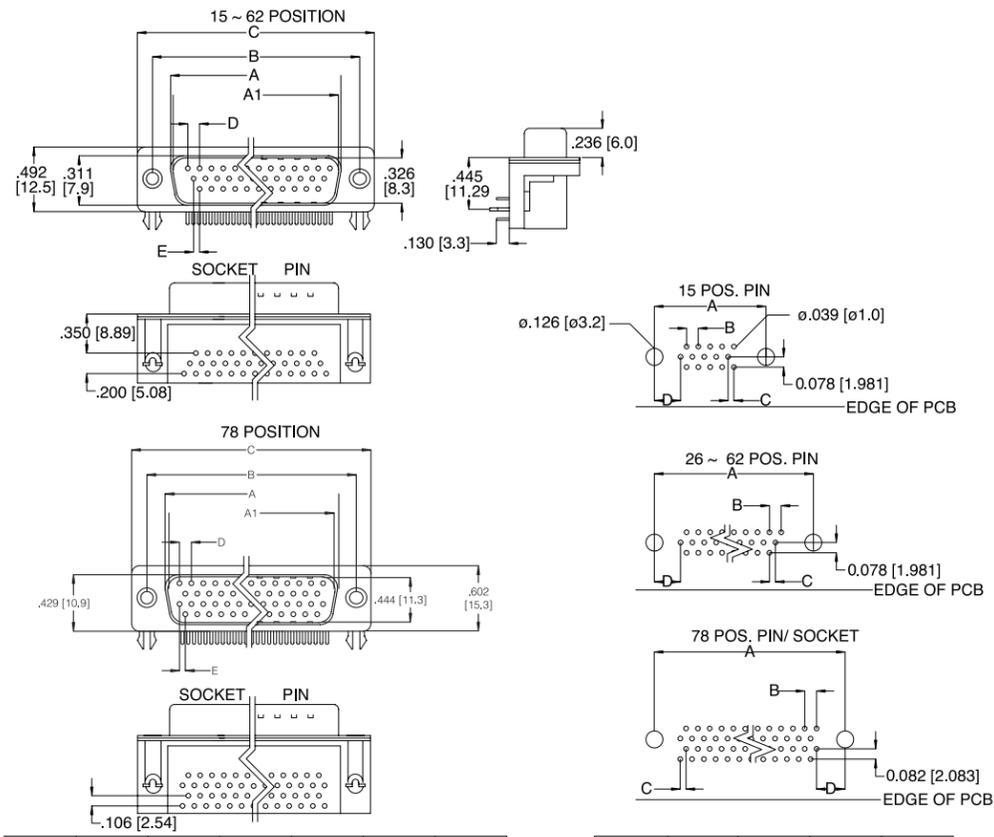

CONTACTS	A SOCKET	A1 PIN	B	C	D	E
15	.642 [16.30]	.666 [16.92]	.984 [25.0]	1.213 [30.8]	.090 [2.29]	.045 [1.145]
26	.969 [24.6]	.994 [25.25]	1.311 [33.3]	1.543 [39.2]	.090 [2.29]	.045 [1.145]
44	1.508 [38.3]	1.534 [38.96]	1.854 [47.1]	2.091 [53.1]	.090 [2.29]	.045 [1.145]
62	2.157 [54.8]	2.182 [55.42]	2.50 [63.5]	2.732 [69.4]	.095 [2.41]	.047 [1.205]
78	2.05 [52.20]	2.079 [52.81]	2.40 [61.0]	2.638 [67.0]	.095 [2.41]	.047 [1.205]

CONTACTS	A	B	C	D
15	.984 [25.0]	.090 [2.29]	.045 [1.145]	.277 [7.04]
26	1.311 [33.3]	.090 [2.29]	.045 [1.145]	.271 [6.88]
44	1.854 [47.1]	.090 [2.29]	.045 [1.145]	.271 [6.88]
62	2.50 [63.5]	.095 [2.41]	.047 [1.205]	.275 [7.00]
78	2.402 [61.0]	.095 [2.41]	.047 [1.205]	.300 [7.63]

ORDERING INFORMATION

17EBH Series High Density D-Sub

Front Metal Shell, Right-Angle PC Mount

17EBH 0XX X XX X XX

Series  
Number Of Positions  
15, 26, 44, 62, 78  
Type  
P Pin (male)  
S Socket (female)

PCB Mount Options  
00 Clear hole  
10 Arrowhead Board  
Panel Mounting Options  
0 .120 (3.05) Clear Hole  
1 #4-40 Threaded Hole  
2 #4-40 Fixed Female Screw  
Plating Code  
AA Gold Flash over Nickel  
AM 30µ\* (.76µm) Gold over Nickel

**DIMENSIONS**

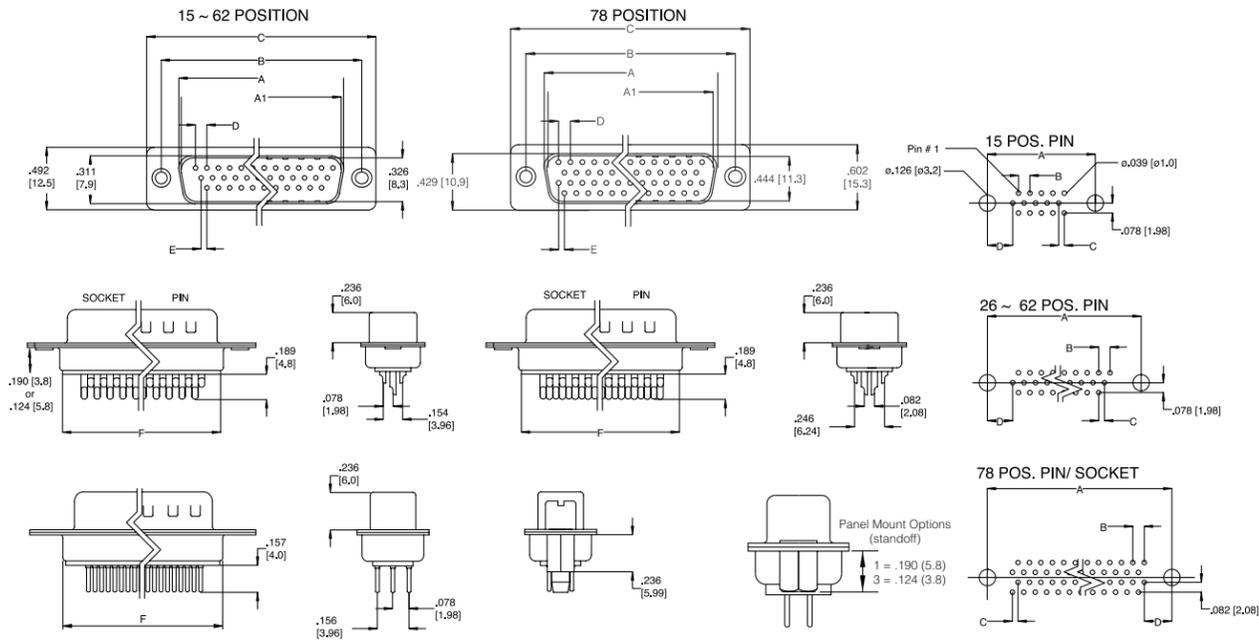

CONTACTS	A SOCKET	A1 PIN	B	C	D	E	F
15	.642 [16.30]	.666 [16.92]	.984 [25.0]	1.213 [30.8]	.090 [2.29]	.045 [1.145]	.756 [19.2]
26	.969 [24.6]	.994 [25.25]	1.311 [33.3]	1.543 [39.2]	.090 [2.29]	.045 [1.145]	1.071 [27.2]
44	1.508 [38.3]	1.534 [38.96]	1.854 [47.1]	2.091 [53.1]	.090 [2.29]	.045 [1.145]	1.618 [41.1]
62	2.157 [54.8]	2.182 [55.42]	2.50 [63.5]	2.732 [69.4]	.095 [2.41]	.047 [1.205]	2.256 [57.3]
78	2.05 [52.20]	2.079 [52.81]	2.40 [61.0]	2.638 [67.0]	.095 [2.41]	.047 [1.205]	2.169 [55.1]

CONTACTS	A	B	C	D
15	.984 [25.0]	.090 [2.29]	.045 [1.145]	.277 [7.04]
26	1.311 [33.3]	.090 [2.29]	.045 [1.145]	.277 [7.04]
44	1.854 [47.1]	.090 [2.29]	.045 [1.145]	.277 [7.04]
62	2.50 [63.5]	.095 [2.41]	.047 [0.120]	0.699
78	2.402 [61.0]	.095 [2.41]	.047 [0.120]	0.699

**ORDERING INFORMATION**

**17E HD Series High Density D-Sub**

*Solder Cup & Straight P.C. Mount, Front Metal Shell Fixed Contact*

**17EHD 0XX X XX X XX**

Series  
 Number Of Positions  
 15, 26, 44, 62, 78  
 Type  
 P Pin (male)  
 S Socket (female)

**Termination Types:**  
 00 Solder Cup  
 30 Board-mount, Vertical  
 32 Board-mount, Vertical with Boardlocks  
 33 Board-mount, Vertical with standoff,  
 no boardlock

**Panel Mounting Options:**  
 0 .120 (3.05) Clear Hole  
 1 #4-40 Threaded Hole .190 (5.8)  
 2 #4-40 Fixed Female Screwlock  
 3 #4-40 Threaded Hole .124 (3.8)

**Plating Code:**  
 AA Gold Flash over Nickel  
 AM 30µ\* (.76µm) Gold over Nickel

INCHES (MM)

**Right-Angle Board Mount Connectors  
Front Metal Shell**

**SPECIFICATIONS:**

**MATERIALS AND PLATINGS**

Shells	Steel, tin plated
Contacts	Precision formed copper alloy
Contact Plating	Gold over nickel
Contact Forces	Engagement: 12 oz. max. (340.2 g) Separation: .75 oz. min. (21.26 g)

**ELECTRICAL DATA**

Current Rating	5 amps
Dielectric Withstanding Voltage	1000 VAC/60 sec.
Dielectric	Glass filled thermoplastic, black, UL 94 VO
Contact Resistance	15 milliohms max.

**CLIMATIC DATA**

Temperature Range	-67°F (-55°C) to 221°F (105°C)
-------------------	--------------------------------

**6E17 SERIES**

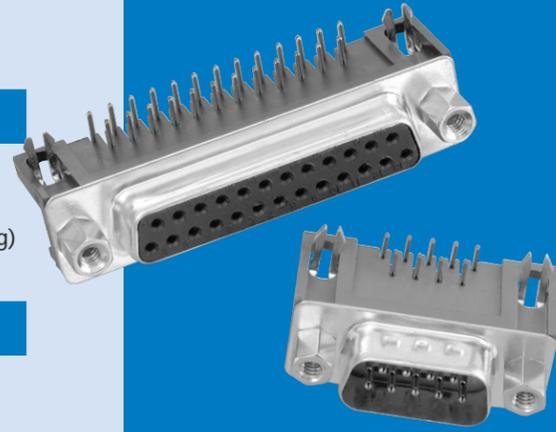

Amphenol's 6E17 series of right angle commercial connectors provide high performance at competitive prices.

The front metal shell helps to provide reduced EMI/ RFI emissions, and the contacts are selectively plated to provide additional high performance. The 6E17 series are available in a variety of board mounting and grounding options including arrowhead boardlocks and #4-40 threaded inserts.

Front mounting holes are also available threaded, un-threaded and with installed female hex screwlocks.

- Industrial
- Telecom
- Any industry standard I / O connections

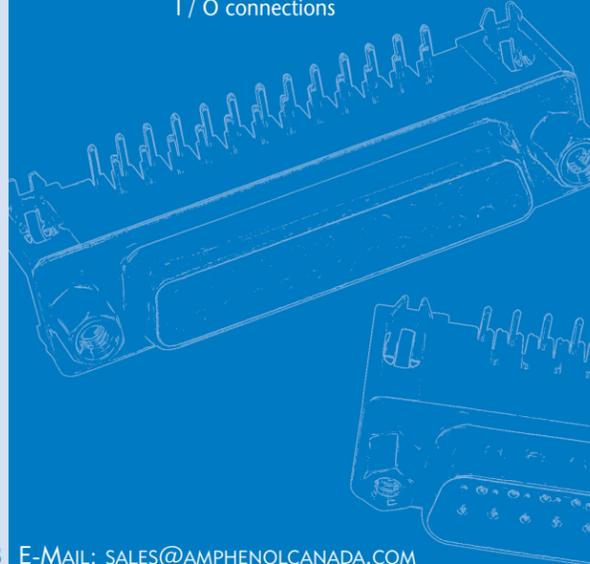

DIMENSIONS

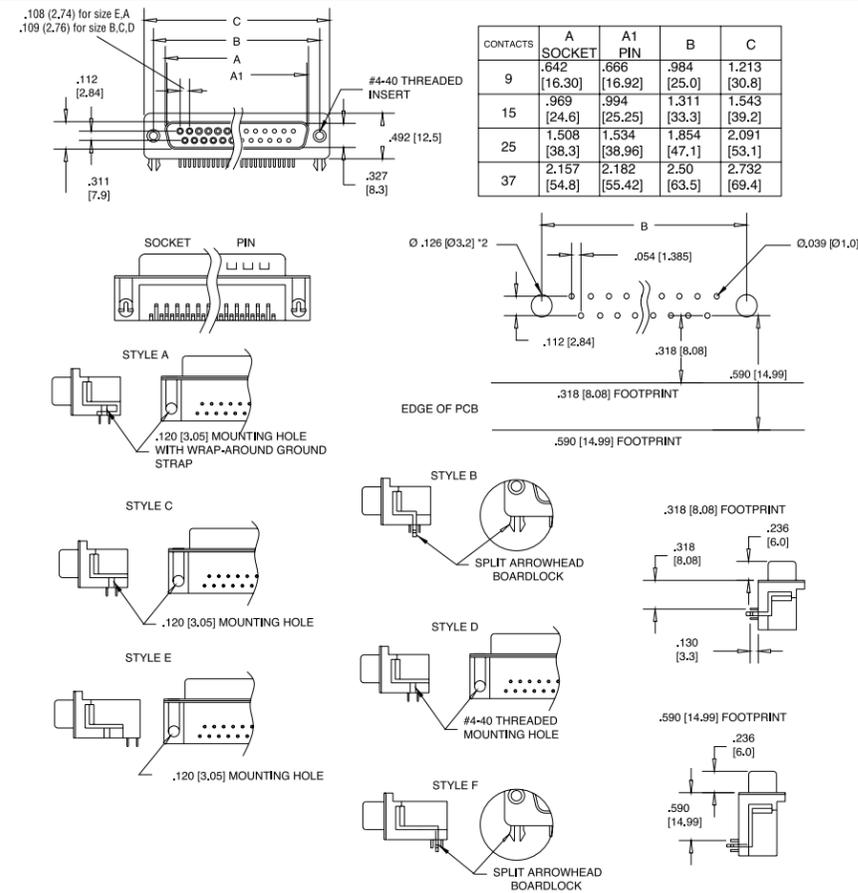

ORDERING INFORMATION

Series: **6E17 X**    **0XX**    **X**    **XX**    **X**    **XX**    **X**

Number of Contacts: 09, 15, 25, 37

.318 (8.08) Footprint	.590 (14.99) Footprint	Description of PC Board Mounting Characteristics	Style
A		.120 (3.05) diameter mtg hole with wrap-around ground strap	A
C		split arrowhead boardlock	B
D	U	.120 (3.05) diameter mtg hole	C&E
J		#4-40 threaded mtg hole	D
	Y	split arrowhead boardlock	F

**Code**  
P Pin (male)  
S Socket (female)

**Contact Type**  
Pin (male)  
Socket (female)

**Contact**  
20 Tin plated receptacle  
21 Tin plated plug with grounding indents

**Code**  
0 .120 (3.05) clear hole  
1 #4-40 threaded hole  
2 #4-40 threaded hole with female screwlock  
4 Fixed female round screwlock

**Code**  
BF **Contact Plating**  
Engagement area 3µ" (.076µm) gold flash, terminal end area 100µ"/200µ" (2.54µm/5.08µm) tin/lead underplate of 50µ" (1.27µm) nickel  
CF Engagement area 15µ" (.381µm) gold flash, terminal end area 100µ"/200µ" (2.54µm/5.08µm) tin/lead underplate of 50µ" (1.27µm) nickel  
AJ Engagement area 30µ" (.76µm) gold, terminal end area 100µ"/200µ" (2.54µm/5.08µm) tin/lead underplate of 50µ" (1.27µm) nickel

Variation Code: E for U & Y Footprint

**Panel Mounting Options**  
0 .120 (3.05) clear hole  
1 #4-40 threaded hole  
2 #4-40 threaded hole with female screwlock  
4 Fixed female round screwlock

**Contact Plating**  
BF Engagement area 3µ" (.076µm) gold flash, terminal end area 100µ"/200µ" (2.54µm/5.08µm) tin/lead underplate of 50µ" (1.27µm) nickel  
CF Engagement area 15µ" (.381µm) gold flash, terminal end area 100µ"/200µ" (2.54µm/5.08µm) tin/lead underplate of 50µ" (1.27µm) nickel  
AJ Engagement area 30µ" (.76µm) gold, terminal end area 100µ"/200µ" (2.54µm/5.08µm) tin/lead underplate of 50µ" (1.27µm) nickel

For filtered version, see page 56.

Dual Port Connectors

SPECIFICATIONS:

MATERIALS AND PLATINGS

Shells	Steel, tin plated
Contacts	Precision formed copper alloy
Contact Plating	Gold over nickel
Contact Forces	Engagement: 12 oz. max. (340.2 g) Separation: .75 oz. min. (21.26 g)

ELECTRICAL DATA

Current Rating	5 amps
Dielectric Withstanding Voltage	1000 VAC/60 sec.
Dielectric	Glass filled thermoplastic, black, UL 94 VO
Contact Resistance	15 milliohms max.

CLIMATIC DATA

Temperature Range	-67°F (-55°C) to 221°F (105°C)
-------------------	--------------------------------



6E17 H SERIES

Amphenol's 61E7 series dual port connectors are a state of the art design. The front metal shell helps reduce EMI/RFI emissions.

Contacts are selectively plated for high performance at a low cost.

Designed to save PC board space, Amphenol's dual port "D" provides two input output connectors in a minimal amount of board space.

These connectors are available with various stacking options: same gender, mixed gender and multiple pin counts.

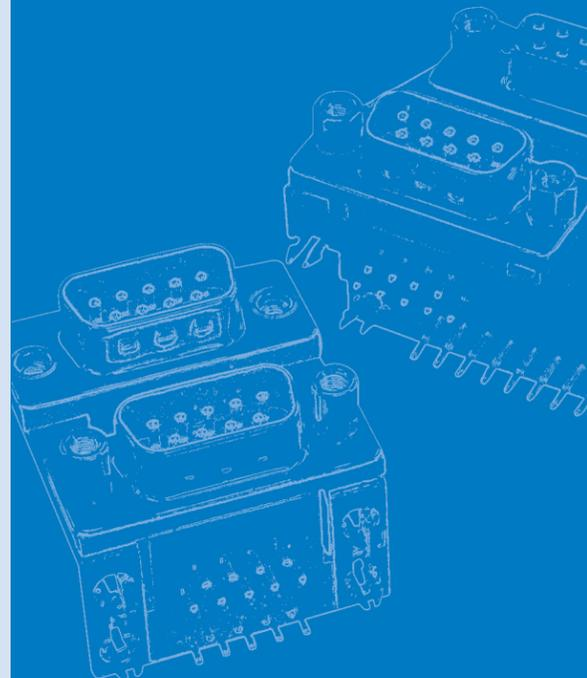

INCHES (MM)



**DIMENSIONS**

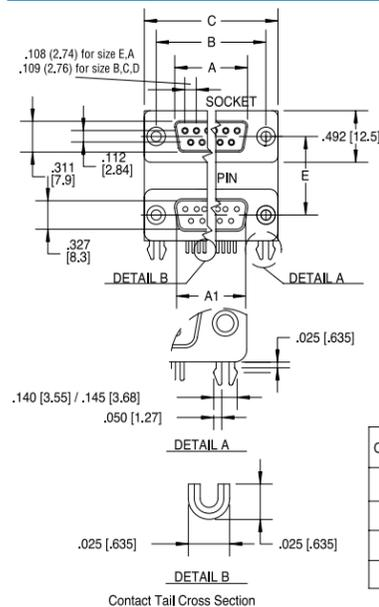

CONTACTS	A SOCKET	A1 PIN	B	C
9	.642 [16.30]	.666 [16.92]	.984 [25.0]	1.213 [30.8]
15	.969 [24.6]	.994 [25.25]	1.311 [33.3]	1.543 [39.2]
25	1.508 [38.3]	1.534 [38.96]	1.854 [47.1]	2.091 [53.1]
37	2.157 [54.8]	2.182 [55.42]	2.50 [63.5]	2.732 [69.4]

Code Letter	Product Description		Dimensions	
	Top Connector	Bottom Connector	E	F
A	Pin	Pin	0.900 ± 0.010 (22.86 ± 0.25)	1.415 (35.94)
B	Socket	Socket		
C	Pin	Socket		
D	Socket	Pin	0.750 ± 0.010 (19.05 ± 0.25)	1.265 (32.13)
E	Pin	Pin		
F	Socket	Socket		
G	Pin	Socket	0.625 ± 0.010 (15.88 ± 0.25)	1.140 (28.96)
H	Socket	Pin		
J	Pin	Pin		
K	Socket	Socket		
L	Pin	Socket		
M	Socket	Pin		

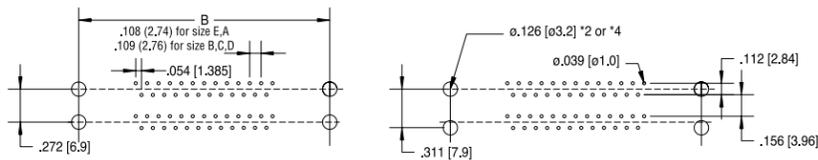

PCB EDGE

**ORDERING INFORMATION**

**6E17H X XX X XX X XX X**

**Series**  
6E17H Dual port;  
right angle solder tail

**Code Boardlock**  
C Boardlock option  
O No PC boardlock

**Code Number of Contacts**  
18 2 x 9      15 15 over blank  
30 2 x 15      34 9 / 25  
50 2 x 25      43 25 / 9+9  
74 2 x 37      H15A VGA / Triple Audio  
40 15 / 25

**Variation Code**  
L for .311 (7.89) Footprint

**Code Housing Characteristics**  
00 Steel shell, tin plated receptacles without  
grounding dimples (options B, F, K)  
01 Steel shells, tin plated plugs with grounding  
dimples (options A, E, J)  
03 Steel shells, tin plated, plug shell with grounding  
dimples and receptacle shell without dimples (options C,G,L,D,H,M)

**Code Panel Mounting Options**  
0 120° clear hole  
1 #4-40 threaded hole  
2 #4-40 threaded hole with female screwlock

**Code Contact Plating**  
BF Engagement area 3µ (.076µm) gold flash,  
terminal end area 100µ/200µ tin/lead, (2.54µm/5.08µm)  
tin/lead underplate of 50µ (1.27µm) nickel  
CF Engagement area 15µ (.381µm) gold flash,  
terminal end area 100µ/200µ (2.54µm/5.08µm)  
tin/lead underplate of 50µ (1.27µm) nickel  
AJ Engagement area 30µ (.76µm) gold, terminal end area  
100µ/200µ (2.54µm/5.08µm) tin/lead underplate  
of 50µ (1.27µm) nickel

*Consult factory for other available configurations*

58.064 (22.86) Spacing	48.388 (19.05) Spacing	40.31 (15.87) Spacing	Product Description	
			Top Connector	Bottom Connector
A	E	J	Pin	Pin
B	F	K	Socket	Socket
C	G	L	Pin	Socket
D	H	M	Socket	Pin

For filtered version, see page 55.

**High Temperature  
Straight Board Mount Connectors**

**SPECIFICATIONS:**

**MATERIALS AND PLATINGS**

Shells	Steel/nickel plated
Contacts	Precision formed copper alloy
Contact Plating	Gold over nickel

**ELECTRICAL DATA**

Current Rating	5 amps
Voltage Rating	600 V
Dielectric	Glass filled thermoplastic, black, UL 94 VO
Contact Resistance	10 milliohms (max.)

**CLIMATIC DATA**

Temperature Range	Environmental: -67°F (-55°C) to 302°F (150°C)
Process Compatibility	IR-Air Convection 500°F (260°C) for 20 seconds

**6E17S SERIES**

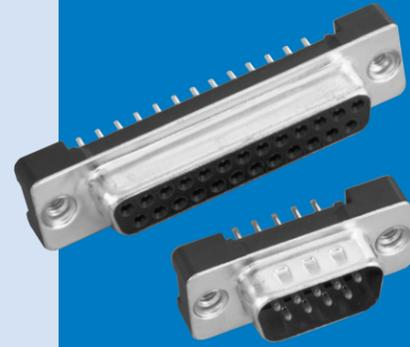

Amphenol's high temperature, low profile D-Sub connector gives you a high quality, reliable commercial connector to meet today's market demands.

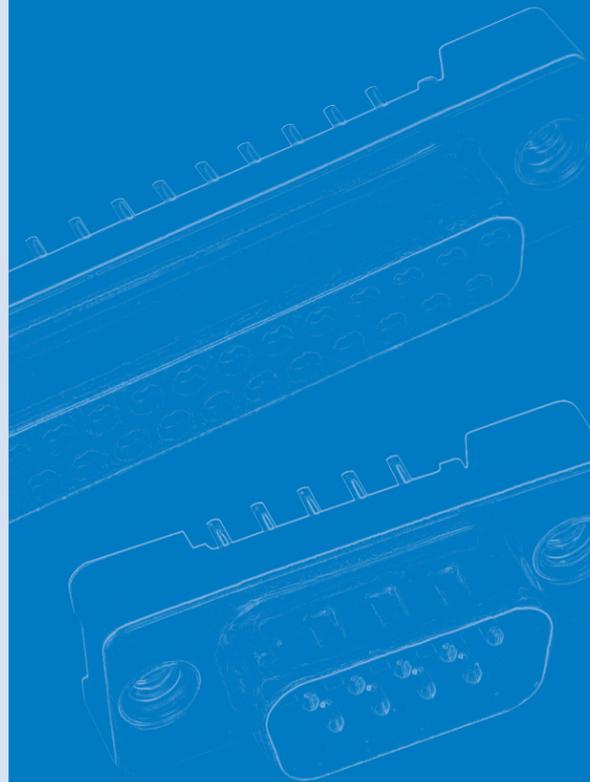

**DIMENSIONS**

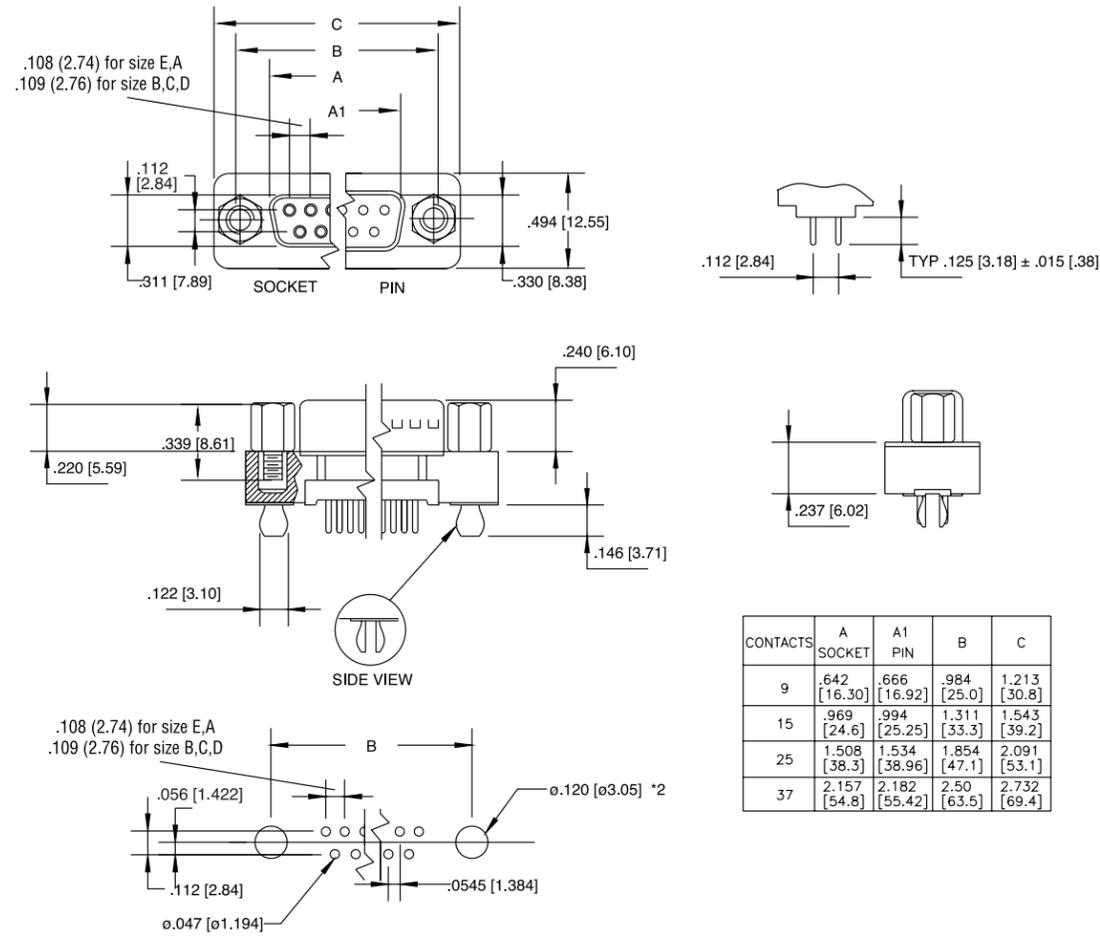

**ORDERING INFORMATION**

**6E17S C OXX X XX X XX**

**Series** —————

**Code Boardlock** —————

C Split arrowhead boardlock  
O No boardlock

**Number of contacts** —————

9, 15, 25 or 37

**Code Gender** —————

P Pin (male)  
S Socket (female)

**Code Contact Plating** —————

BJ Engagement area 10µ" (2.54µ) gold,  
terminal end area 100µ"200µ" (2.54µ/5.08µ)  
-tin/lead, underplate of 50µ" (1.27µ) nickel

AJ Engagement area 30µ" (.76µ) gold,  
terminal end area 100µ"200µ" (2.54µ/5.08µ)  
-tin/lead, underplate of 50µ" (1.27µ) nickel

**Code Housing Characteristics**

20 Tin plated receptacle  
21 Tin plated

**Code Panel Mounting Options**

1 #4-40 threaded hole  
2 #4-40 threaded hole with female screwlock  
3 M-3 threaded hole

# ED-EHD

D-Sub connectors - Screw-machined contacts

## STANDARD AND HIGH DENSITY WATERPROOF CONNECTORS



CHARACTERISTICS

Materials and Platings	
<b>Shells</b>	Steel 2.5µm(100µ") min tin over 1.25µm(50µ") min nickel
<b>Body</b>	Glass-filled thermoplastic Flame retardant to UL94 V-0 Color Black
<b>Contacts</b>	Copper alloy(Brass for plug, Phosphor bronze for socket) gold over 1.25µm(50µ") min nickel
<b>Boardlock</b>	Copper alloy, 100µ" min. sn over 50µ" min. nickel.
<b>Standoff</b>	Copper alloy, 100µ" min. sn over 50µ" min. nickel.

Electrical Data	
<b>Current rating</b>	5.0A
<b>Voltage rating</b>	300V rms at 50Hz
<b>Insulation resistance</b>	>5000MΩ
<b>Contact resistance</b>	20mΩ Max.

Climatic Data	
<b>Operating temperature</b>	-55°C to +85°C
<b>Salt spray</b>	48 hours
<b>Waterproof rating</b>	IP 67 minimum

Mechanical Data					
<b>Mating and unmating force</b>					
Unit: kg (lb)					
No. of Cts		ED		EHD	
ED	EHD	Mate (max)	Unmate (min)	Mate (max)	Unmate (min)
9	15	3.05 (6.74)	0.36 (0.79)	3.81 (8.42)	0.52 (1.14)
15	26	5.09 (11.24)	0.46 (1.01)	5.95 (13.16)	1.05 (2.32)
25	44	8.44 (18.66)	0.81 (1.80)	9.26 (20.46)	1.37 (3.02)
<b>Mating cycles</b>		Gold flash : 100 cycles 0.76µm (30µ") : 500 cycles			

DESCRIPTION

The 17ED and 17EHD series are suitable for waterproof applications.

The machined contacts provide robustness and reliability.

This series offers:

- Panel mount connectors with solder cup, straight and right angle PCB terminations.

Connectors are waterproof unmated.

*Harsh environment connectors*

APPLICATIONS

- Marine electronic devices
- Industrial electrical
- Security Monitoring
- Robotics
- Lighting systems

ED-EHD

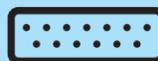

Amphenol

Solder cup (blank) :

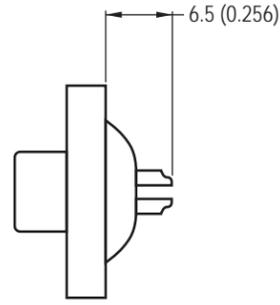

Standard density

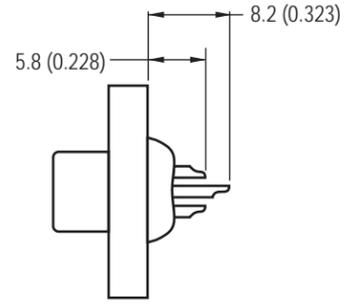

High density

Straight PCB with standoff and boardlocks:

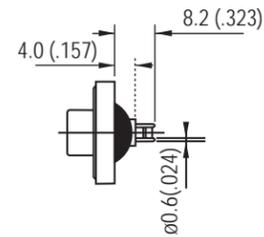

Standard density

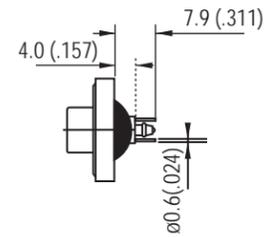

High density

Right angle PCB with brackets and boardlocks:

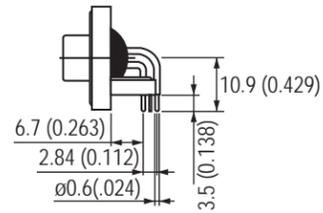

Standard density

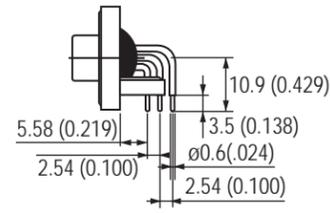

High density

Right angle PCB without brackets and boardlocks:

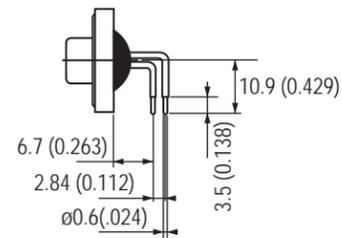

Standard density

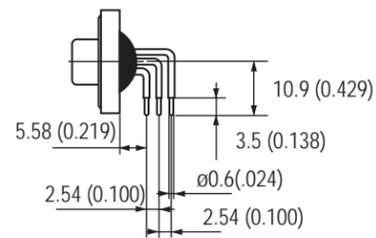

High density



Shell Size Dimensions

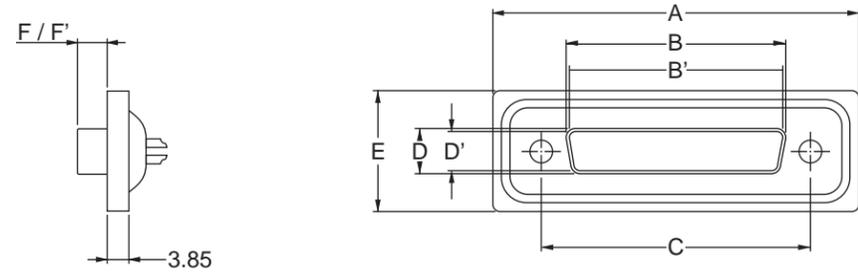

SHELL SIZE	Contact P: pin S: socket	A	B	B'	C	D	D'	E	F	F'
		±0.25 (±.010)	0 / -0.20 (0 / -.008)	+0.20 / 0 (+.008 / 0)	±0.10 (±.004)	0 / -0.25 (0 / -.010)	+0.25 / 0 (+.010 / 0)	±0.25 (±.010)	+0.10 / -0.20 (+.004 / -.008)	±0.10 (±.004)
E	P	39.4		16.8(0.661)	25.0		8.2(0.325)	21.0		5.9(0.232)
	S	(1.551)	16.4(0.646)		(0.984)	8.0(0.315)		(0.827)	6.2(0.244)	
A	P	47.7		25.1(0.988)	33.3		8.2(0.325)	21.0		5.9(0.232)
	S	(1.878)	24.8(0.976)		(1.311)	8.0(0.315)		(0.827)	6.2(0.244)	
B	P	64.5		28.8(1.528)	47.0		8.2(0.325)	21.0		5.9(0.232)
	S	(2.539)	38.5(1.513)		(1.850)	8.0(0.315)		(0.827)	6.2(0.244)	

Panel cutouts

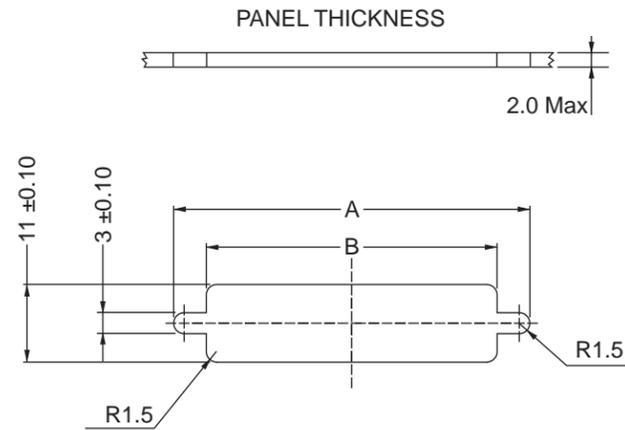

SHELL SIZE	A	B
	±0.10(±.004)	0 / -0.10(0 / -.004)
E	28.8 (1.111)	20.0 (0.788)
A	36.5 (1.438)	28.0 (1.103)
B	51.0 (2.009)	41.5 (1.635)

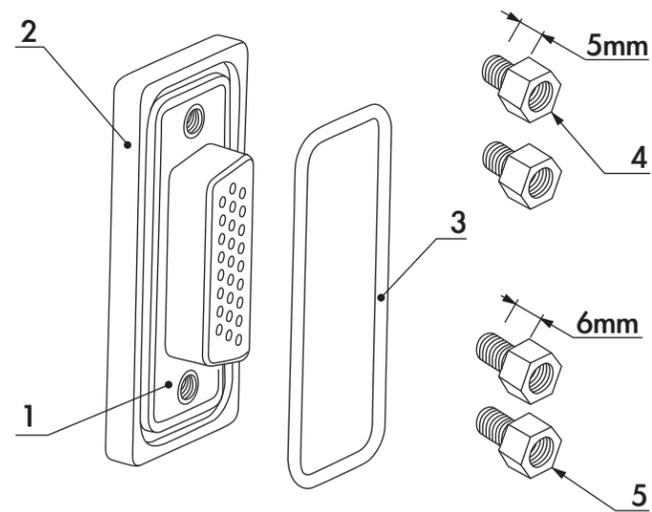

NO	Description	Material	Qty
2	Housing	Black thermoplastic UL 94-VO	1
1	Front shell	Steel tin plated	1
3	Ring	Silicone	1
4	#4-40 Front screw lock	Brass tin plated	2
5	#4-40 Front screw lock	Brass tin plated	2

### How to order

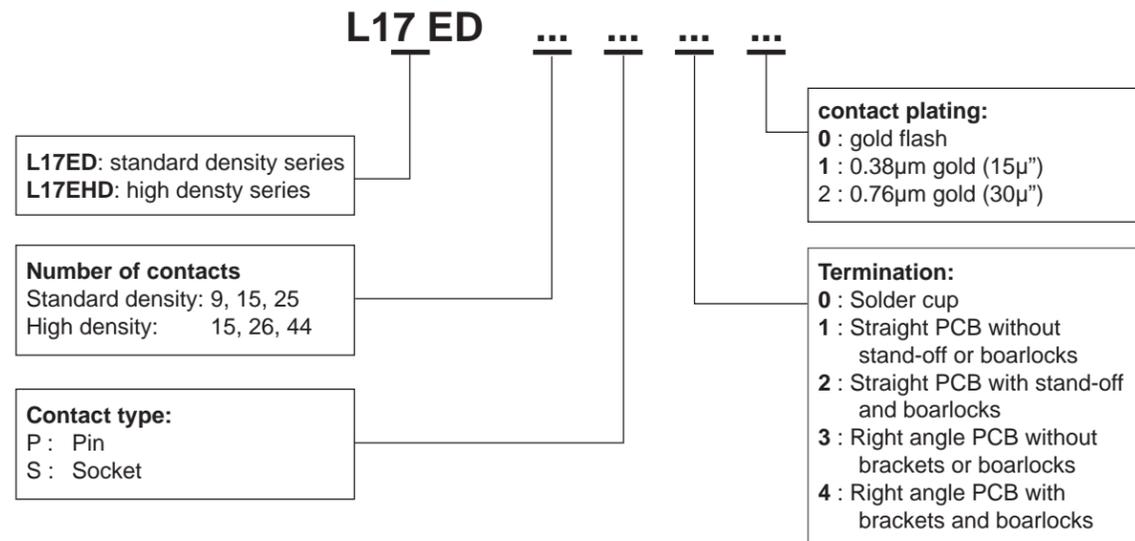

*For special request, please consult factory*

Do not hesitate to contact us for further information

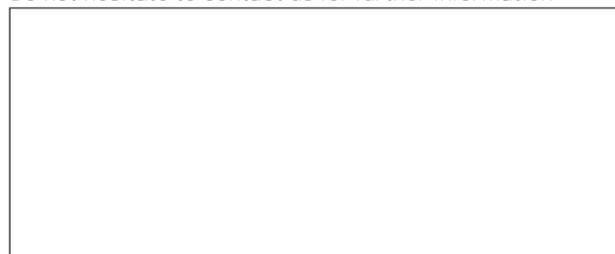

## Amphenol

### Amphenol IT & Communication Products

Block A3/A4, The 4th Industrial District of  
Industrial Headquarters, Dong Keng Road  
Gong Ming Town, Shen Zhen China  
Fax: +86(0)755 2754 9955

#### Technical Support

Tel: +86(0)755 2717 7945  
Info-dsub@amphenol.com.cn  
<http://www.dsubconnector.com>



# TW

## Hybrid D'Sub series



CONTENT

### Specifications

- Connectors according to: MIL C24308 - NFC93425 - HE507

Materials and platings		Electrical Data	
Shells	Steel-Tin plating	Current rating	
Insulators	High temperature black thermoplastic	Signal contacts	7.5 A. with 10 A. peaks
Signal contacts	Female: machined bronze	Power contacts	
Material	Male: machined brass	PCB terminations	10 to 40 A.
Plating finish	16µ "Au over 79µ" Ni min.	Solder cup terminations	10 to 40 A.
Or	30µ "Au over 79µ" Ni min.	Crimp terminations	10 to 40 A.
Shielded contacts	Female: machined bronze	Shielded contacts	0.5 A.
Material	Male: machined brass	Voltage rating	
Plating		Signal and power contacts	300 V.R.M.S. at 50 Hz
Inner conductor	16µ "Au or 30µm Au over 79µ" Ni	Shielded contacts	150 V.R.M.S. at 50 Hz
Outer ring	10µ "Au over 79µ" Ni	Shielded contacts	
Terminations	Tinned	Frequency range	0-1 GHz
Except solder cup and crimp terminations	gold flash	Attenuation	0.2dB
Power contacts	Female: machined bronze	V. S. W. R.	1.4(+0.04/GHz)
Material	Male: machined brass	Characteristic impedance	50 Ohms
Plating		Dielectric withstanding	
Contacts	16µ "Au or 30µ" Au over 79µ" Ni	voltage	≥ 1000 V.R.M.S. at 50Hz
Terminations	Tinned	Insulation resistance	≥ 5000 M Ohms at 500 VDC
Except solder cup and crimp terminations	gold flash	Contact resistance	≤ 5m Ohms
Brackets	Steel-Tin plating	Shell resistance	≤ 1m Ohm
Front jackscrews	Brass-Tin plating	(electrical grounding)	
Rear clinch nuts	Brass-Tin plating		
Boardlocks	Bronze-Tin plating		
Stand-off	Brass-Tin plating		

Climatic Data		Mechanical data	
Operating temperature	-55°C + 155°C (with peaks up to 180°C)	Shells	With or without dimples
Damp heat	56 days (40°C - 95% HR)	Contact retention force in dielectric material	> 40N
Salt spray	48 hours	Maximum mating and unmating force	
		With dimples	E size = 70 N A size = 80 N B size = 100 N C size = 150 N D size = 180 N
		Without dimples	E size = 30 N A size = 50 N B size = 80 N C size = 120 N D size = 160 N
		Compatible with process	
		IR - Air convectioned	260° for 20 s.
		Resistance to solder iron heat	260°C for 30 s.
		Mating cycles	≥ 200 (classe II) or 500 (classe I)
		Blind mating system	Available upon request
		Polarization	Available with locking accessories Consult factory



DESCRIPTION

Amphenol D'Sub TW Hybrid Series permits a mix of contacts including signal, power, shielded, high voltage and fiber optics in the same housing with 18 different contacts arrangements.

This economic series was first developed from our military series, and has improved features:

- new contacts
- new high temperature black thermoplastic insert
- PCB configurations come preloaded with fixed contacts and brackets.

These connectors are supplied with screw machined contacts which are fixed in the insulator.

A complete range of housings are also available for cable application.

*A full range of arrangements compatible with reflow process*

APPLICATIONS

- Commercial
- Medical
- Industrial
- Telecom
- Any application requiring optimization of space

TW / E1



**Amphenol**



**CLASS II**

0.4µm (16µ") Au contacts gold plating  
200 mating cycles

Types	Shells and plating
77 TW	Tin plated shell <i>*Male and female</i>
717 TW	Tin plated shell with dimples <i>Male only</i>

**CLASS I**

0.76µm (30µ") Au contacts gold plating  
500 mating cycles

Types	Shells and plating
177 TW	Tin plated shell <i>*Male and female</i>
777 TW	Tin plated shell with dimples <i>Male only</i>

*Housing arrangements*

**Male front view**

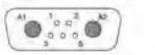
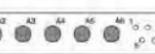
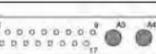
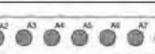
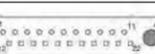
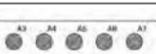
Arrangement ..... Shell size .....	 5W1 E	 7W2 A	 11W1 A
Arrangement ..... Shell size .....	 3W3 A	 5W5 B	 9W4 B
Arrangement ..... Shell size .....	 13W3 B	 17W2 B	 21W1 B
Arrangement ..... Shell size .....	 27W2 C	 13W6 C	 17W5 C
Arrangement ..... Shell size .....	 21W4 C	 8W8 C	 25W3 C
Arrangement ..... Shell size .....	 24W7 D	 36W4 D	 43W2 D

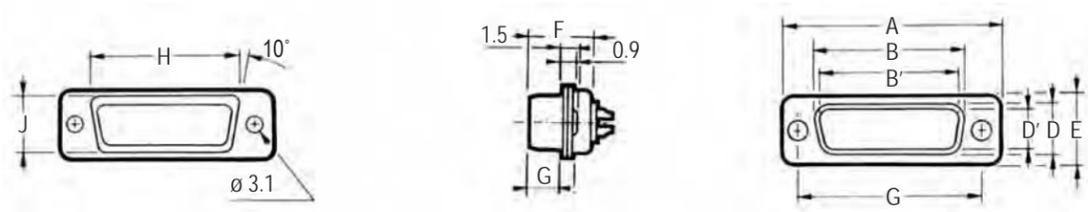

Shell size	Contact P: Pin S: Socket	A ±0.25 (±.010)	B 0/-0.20 (0/-0.008)	B' +0.20/0 (+.008/0)	C ±0.10 (±.004)	D 0/-0.25 (0/-0.010)	D' +0.25/0 (+.010/0)	E ±0.20 (±.008)	F +0.05/-0.20 (+.002/-0.008)	F' +0.10/-0.20 (+.004/-0.008)	G +0.10/-0.20 (±.004)	G' ±0.10 (±.004)	H +0.10/-0.40 (+.004/-0.016)	J 0/-0.50 (0/-0.020)
E	P	30.7 (1.209")		16.8 (.661")	25.0 (.984")		8.2 (.323")	12.4 (.488")		10.9 (.429")		5.9 (.232")	19.4 (.764")	11.0 (.433")
	S		16.4 (.646")			8.0 (.315")			11.1 (.437")		6.2 (.244")			
A	P	39.0 (1.535")		25.1 (.988")	33.3 (1.311")		8.2 (.323")	12.4 (.488")		10.9 (.429")		5.9 (.232")	27.7 (1.091")	11.0 (.433")
	S		24.8 (.976")			8.0 (.315")			11.1 (.437")		6.2 (.244")			
B	P	52.9 (2.083")		38.8 (1.528")	47.0 (1.850")		8.2 (.323")	12.4 (.488")		11.0 (.433")		5.8 (.228")	41.4 (1.630")	11.0 (.433")
	S		38.5 (1.513")			8.0 (.315")			11.1 (.437")		6.2 (.244")			
C	P	69.2 (2.724")		55.3 (2.177")	63.5 (2.500")		8.2 (.323")	12.4 (.488")		11.0 (.433")		5.8 (.228")	57.9 (2.280")	11.0 (.433")
	S		54.9 (2.161")			8.0 (.315")			11.1 (.437")		6.2 (.244")			
D	P	66.8 (2.630")		52.7 (2.075")	61.1 (2.406")		11.0 (.433")	15.2 (.598")		11.0 (.433")		5.8 (.228")	55.5 (2.185")	13.8 (.543")
	S		52.5 (2.067")			10.9 (.429")			11.1 (.437")		6.2 (.244")			

Panel cutouts

Optimal cutout for rear mounting

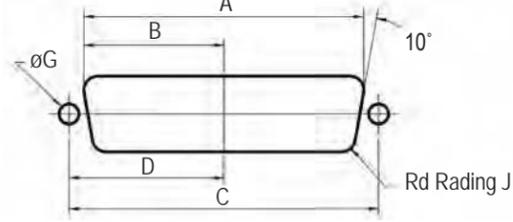

Standard cutout

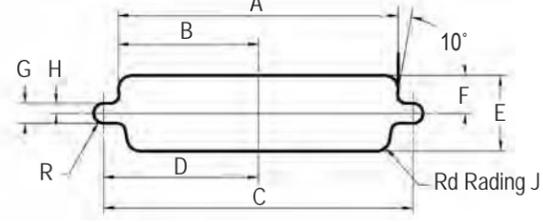

Shell size	Mounting method	A ±0.20 (±.008)	B ±0.20 (±.008)	C ±0.20 (±.008)	D ±0.20 (±.008)	E ±0.20 (±.008)	F ±0.20 (±.008)	G ±0.20 (±.008)	H ±0.20 (±.008)	J ±0.20 (±.008)
E	Front	22.2 (.874")	11.1 (.437")	25.0 (.984")	12.5 (.492")	13.0 (.512")	6.5 (.256")	3.0 (.118")	1.5 (.059")	2.1 (.083")
	Rear	20.5 (.807")	10.2 (.402")			11.4 (.449")	5.7 (.224")			3.4 (.134")
A	Front	30.5 (1.201")	15.3 (.602")	33.3 (1.311")	16.7 (.657")	13.0 (.512")	6.5 (.256")	3.0 (.118")	1.5 (.059")	2.1 (.083")
	Rear	28.8 (1.134")	14.4 (.567")			11.4 (.449")	5.7 (.224")			3.4 (.134")
B	Front	44.3 (1.744")	22.1 (.870")	47.0 (1.850")	23.5 (.925")	13.0 (.512")	6.5 (.256")	3.0 (.118")	1.5 (.059")	2.1 (.083")
	Rear	42.5 (1.673")	21.3 (.839")			11.4 (.449")	5.7 (.224")			3.4 (.134")
C	Front	60.7 (2.390")	30.4 (1.197")	63.5 (2.500")	31.7 (1.248")	13.0 (.512")	6.5 (.256")	3.0 (.118")	1.5 (.059")	2.1 (.083")
	Rear	59.1 (2.327")	29.5 (1.161")			11.4 (.449")	5.7 (.224")			3.4 (.134")
D	Front	58.3 (2.295")	29.2 (1.150")	61.1 (2.406")	30.6 (1.205")	15.8 (.622")	7.9 (.311")	3.0 (.118")	1.5 (.059")	2.1 (.083")
	Rear	56.3 (2.217")	28.2 (1.110")			14.1 (.555")	7.1 (.280")			3.4 (.134")

Straight connector footprint

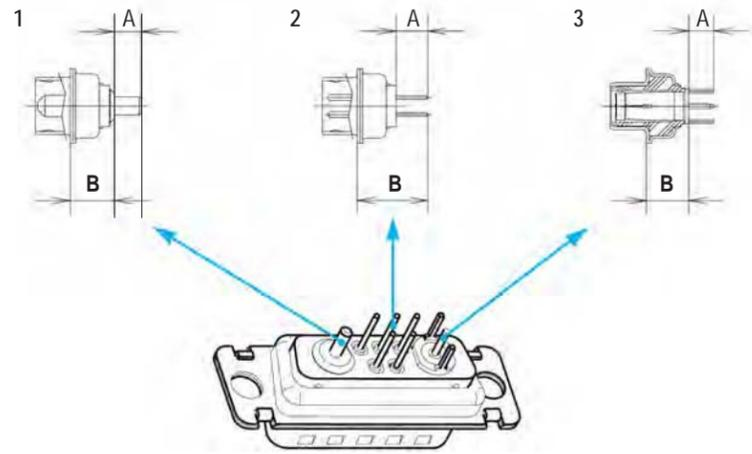

Signal tail 0.6 mm Dia. (.0236")  
 1.6 mm (.063")PCB  
 For other PCB thickness: consult factory.

Description		Dimensions	
		a	b
Power (.126" tail dia.)	1	4.80 mm (.198")	7.2 mm (.283")
Power (.0787" tail dia.)	1	4.80 mm (.198")	7.2 mm (.283")
Shielded	3	4.00 mm (.157")	7.2 mm (.283")
Signal	2	5.00 mm (.196")	11.50 mm (.453")

Straight contact combinations

Arrangement with signal contacts

Arrangement without signal contacts  
 3W3 - 5W5 - 8W8

See above dimensions	Size 8 and 20 Contacts	See above dimensions	Size 8 Contacts
P 3SY	Power 3.2 mm DIA. (.126") (20 to 40 A) and signal	P 3Y	Power only 3.2 mm DIA. (.126") (20 to 40 A)
P 2SY	Power 2 mm DIA. (.0787") (10 to 20 A) and signal	P 2Y	Power only 2 mm DIA. (.0787") (10 to 20 A)
CSY	Shielded and signal	CY	Shielded only
SY	Signal only		
No reference	Signal (Size 20) with solder cup terminations Housing preloaded with contacts		

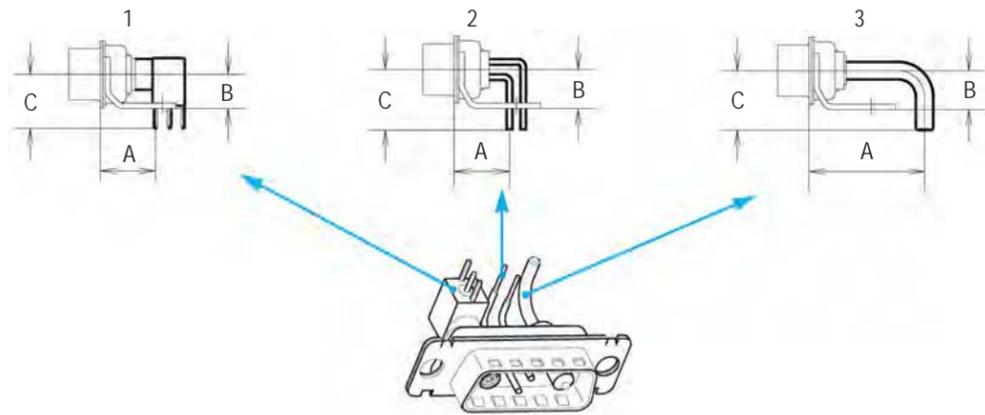

Signal tail 0.6 mm Dia. (.0236")  
 1.6 mm (.063") PCB  
 For other PCB thickness: consult factory.

	Europe			Mix			MIL		
	<b>HE 5 pattern =</b> - Europ. height - Europ. footprint pitch between 2 rows: .100"			<b>Mixed pattern =</b> - MIL height - Europ. footprint pitch between 2 rows: .100"			<b>MIL pattern =</b> - MIL height - MIL footprint pitch between 2 rows: .112"		
Description	a	b	c	a	b	c	a	b	c
Shielded 1	-	-	-	10.30mm (.406")	6.30mm (.248")	10.00mm (.394")	10.30mm (.406")	6.30mm (.248")	10.00mm (.394")
Signal 2	10.30mm (.406")	7.20mm (.283")	11.20mm (.441")	10.30mm (.406")	6.30mm (.248")	9.50mm (.374")	8.10mm (.319")	6.30mm (.248")	9.50mm (.374")
Power (.0787" tail dia.) 3	11.57mm (.456")	7.20mm (.283")	10.50mm (.413")	11.57mm (.456")	6.30mm (.248")	9.50mm (.374")	9.52mm (.375")	6.30mm (.248")	9.50mm (.374")
Power (.126" tail dia.) 3	21.46mm (.845")	7.20mm (.283")	10.50mm (.413")	21.46mm (.845")	6.30mm (.248")	9.50mm (.374")	21.46mm (.845")	6.30mm (.248")	9.50mm (.374")

Note: above dimensions correspond to sizes E to C. Consult factory for D sizes.  
 Connector comes equipped with contacts and brackets.

### Right angle contacts combinations

Arrangement with signal contacts

Arrangement without signal contacts  
 3W3 - 5W5 - 8W8

European footprint	Mixed footprint	MIL (U.S.) footprint	Size 8 and 20 Contacts	European footprint	Mixed footprint	MIL (U.S.) footprint	Size 8 contacts only
↓	↓	↓		↓	↓	↓	
EP3SV	HP3SV	MP3SV	Power 3.2 mm DIA. (.126") (20 to 40 A) and signal	EP3V	HP3V	MP3V	Power only 3.2 mm DIA. (.126") (20 to 40 A)
EP2SV	HP2SV	MP2SV	Power 2 mm DIA. (.0787") (10 to 20 A) and signal	EP2V	HP2V	MP2V	Power only 2.0 mm DIA. (.0787") (10 to 20 A)
-	HCSV	MCSV	Shielded and signal	-	HCV	MCV	Shielded only
ESV	HSV	MSV	Signal only				

**Right angle version**  
**Connectors come equipped with metal brackets**

**BLANK:** 3.10mm (.122") dia mounting hole

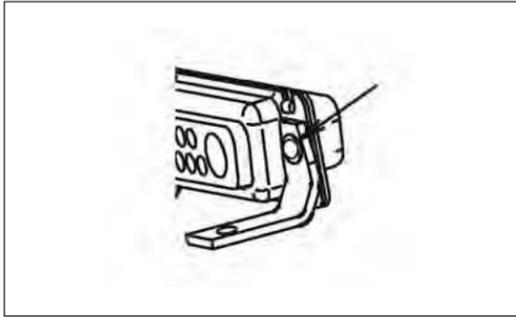

**RM6:** metal brackets + boardlock

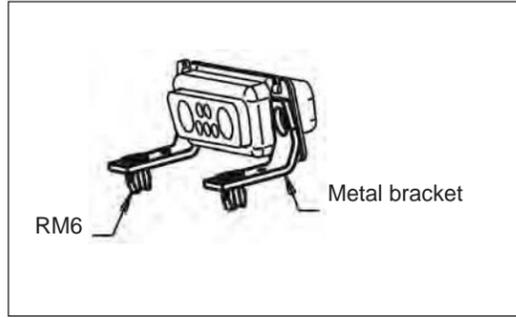

**Straight version**

**BLANK:** 3.10mm (.122") dia mounting hole

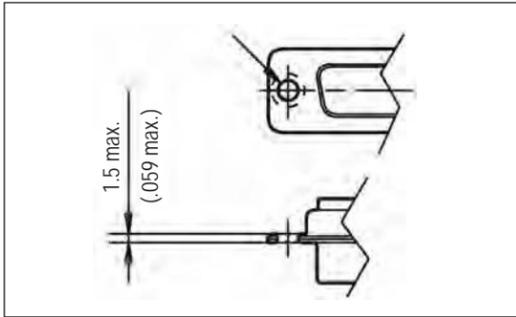

**RM54:** RM5 4.40 threaded  
**RM53:** RM5 M3 threaded

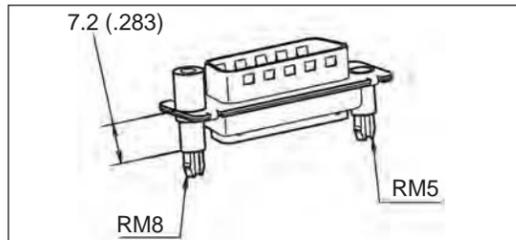

**RM84:** RM8 4.40 threaded  
**RM83:** RM8 M3 threaded

**A514:** blind mating system

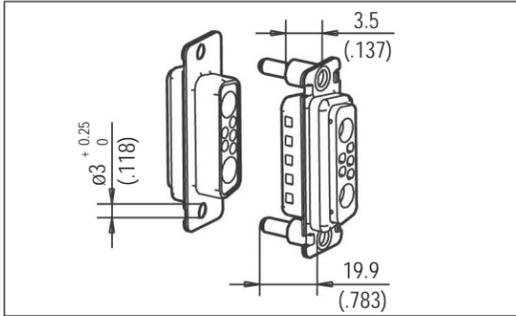

**FM:** float mounting system

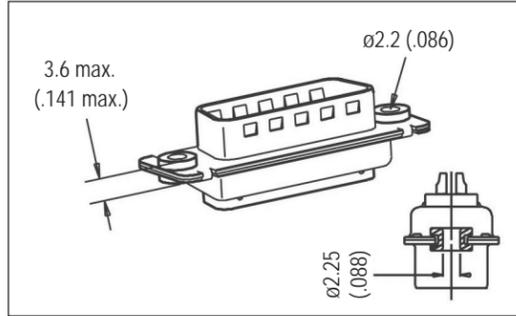

**Straight and right angle version**

**4R:** 4.40 rear nut  
**3R:** M3 rear nut

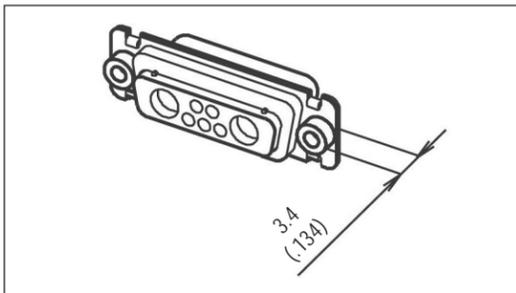

**4F:** 4.40 front female screwlock  
**3F:** M3 front female screwlock

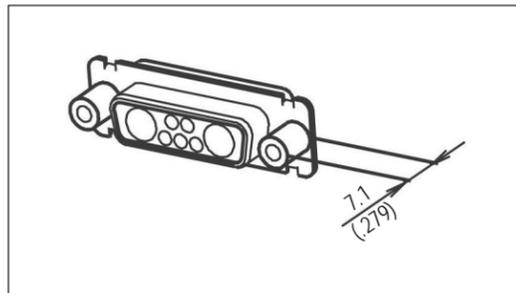

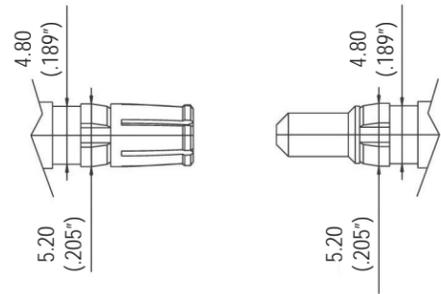

Solder cup version

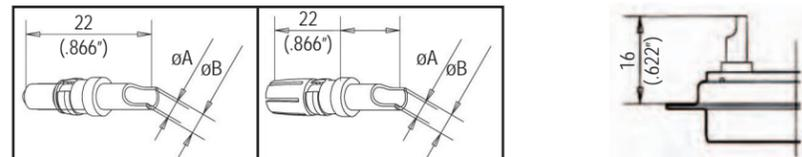

P/N		Current	Dimensions	
Plug	Socket		A mm (inch)	B mm (inch)
L 17DM 53745-8	L 17DM 53744-7	10 to 20 Amp.	1.80 (.071")	2.55 (.100")
L 17DM 53745-7	L 17DM 53744-6	20 to 30 Amp.	2.80 (.110")	3.70 (.145")
L 17DM 53745-1	L 17DM 53744-1	30 to 40 Amp.	4.80 (.189")	5.60 (.220")

Trim dimensions: 7.5 mm (.295")

Crimp version

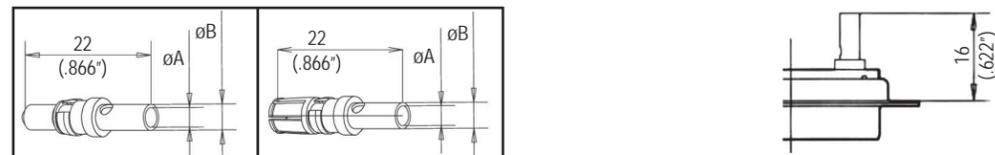

P/N		Current	Dimensions	
Plug	Socket		A mm (inch)	B mm (inch)
L 17DM 53745-208	L 17DM 53744-207	10 to 20 Amp.	1.80 (.071")	2.55 (.100")
L 17DM 53745-207	L 17DM 53744-206	20 to 30 Amp.	2.80 (.110")	3.70 (.145")
L 17DM 53745-201	L 17DM 53744-201	30 to 40 Amp.	4.80 (.189")	5.60 (.220")

Trim dimensions: 7.5 mm (.295")

Crimping tool for all sizes  
L17D479SP



Extraction tool for sizes 8 cts



**Crimp ferrule and inner solder**

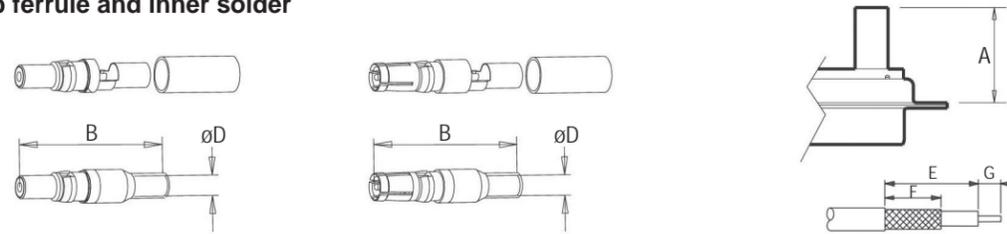

Type	P/N	Dimensions (inch)			Cable - RG	Trim dimensions (inch)		
		A Max	B	D		E	F	G
plug	L17DM 53740	18.8 (740")	23.6 (.929")	1.0 (.039")	178 B/U	7.9 (.311")	6.3 (.248")	2 (.078")
plug	L17DM 53740-1	18.8 (740")	23.6 (.929")	1.7 (.066")	179 B/U 316 B/U	7.9 (.311")	6.3 (.248")	2 (.078")
plug	L17DM 53740-3	21.5 (846")	23.6 (.929")	2.8 (.110")	180 B/U	9.5 (.374")	7.9 (.311")	2 (.078")
plug	L17DM 53740-5	21.5 (846")	23.6 (.929")	3.2 (.126")	58 C/U	9.5 (.374")	7.9 (.311")	2 (.078")
socket	L17DM 53742	18.8 (740")	23.6 (.929")	1.0 (.039")	178 B/U	7.9 (.311")	6.3 (.248")	2 (.078")
socket	L17DM 53742-1	18.8 (740")	23.6 (.929")	1.7 (.066")	179 B/U 316 B/U	7.9 (.311")	6.3 (.248")	2 (.078")
socket	L17DM 53742-3	21.5 (846")	23.6 (.929")	2.8 (.110")	180 B/U	9.5 (.374")	7.9 (.311")	2 (.078")
socket	L17DM 53742-5	21.5 (846")	23.6 (.929")	3.2 (.126")	58 C/U	9.5 (.374")	7.9 (.311")	2 (.078")

**Ferrule and inner solder**

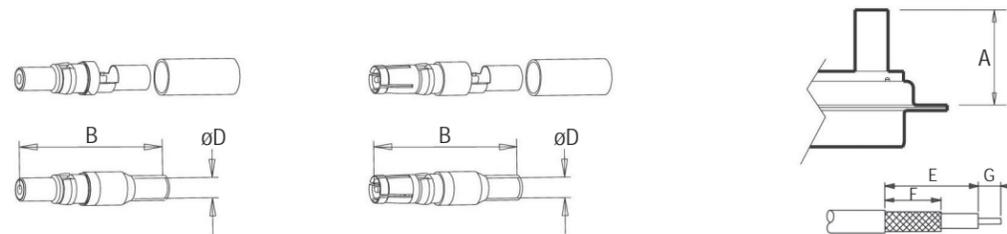

Type	P/N	Dimensions (inch)			Cable - RG	Trim dimensions (inch)		
		A Max	B	D		E	F	G
short plug	L17DM 53740-5000	17.0 (669")	21.8 (.858")	1.0 (.039")	178 B/U	7.9 (.311")	6.3 (.248")	2 (.078")
plug	L17DM 53740-5001	18.8 (740")	23.6 (.929")	1.7 (.066")	179 B/U 316 B/U	7.9 (.311")	6.3 (.248")	2 (.078")
plug	L17DM 53740-5002	21.5 (846")	26.3 (1.035")	2.8 (.110")	180 B/U	9.5 (.374")	7.9 (.311")	2 (.078")
plug	L17DM 53740-5005	21.5 (846")	26.3 (1.035")	3.2 (.126")	58 C/U	9.5 (.374")	7.9 (.311")	2 (.078")
plug	L17DM 53740-5008	18.8 (740")	23.6 (.929")	1.0 (.039")	178 B/U	7.9 (.311")	6.3 (.248")	2 (.078")
short socket	L17DM 53742-5000	17.0 (669")	21.8 (.858")	1.0 (.039")	178 B/U	7.9 (.311")	6.3 (.248")	2 (.078")
socket	L17DM 53742-5001	18.8 (740")	23.6 (.929")	1.7 (.066")	179 B/U 316 B/U	7.9 (.311")	6.3 (.248")	2 (.078")
socket	L17DM 53742-5002	21.5 (846")	26.3 (1.035")	2.8 (.110")	180 B/U	9.5 (.374")	7.9 (.311")	2 (.078")
socket	L17DM 53742-5004	21.5 (846")	26.3 (1.035")	3.2 (.126")	58 C/U	9.5 (.374")	7.9 (.311")	2 (.078")
socket	L17DM 53742-50060	18.8 (740")	23.6 (.929")	1.0 (.039")	178 B/U	7.9 (.311")	6.3 (.248")	2 (.078")

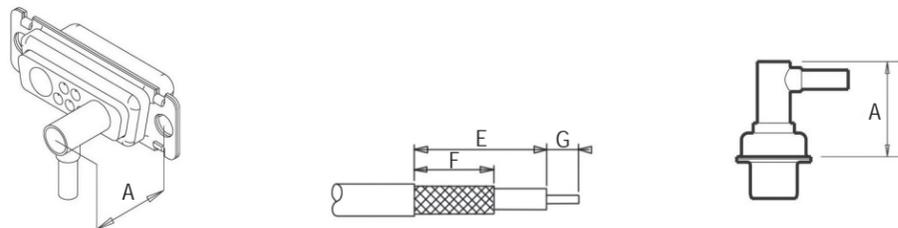
**Crimp ferrule and inner solder**

Type	P/N	Dimensions (inch)			Cable - RG	Trim dimensions (inch)		
		A Max	B	D		E	F	G
plug	L17DM 53741	13.5 (.531")	18.6 (.732")	1.0 (.039")	178 B/U	9.5 (.374")	5.9 (.232")	1.6 (.062")
plug	L17DM 53741-1	13.5 (.531")	18.6 (.732")	1.7 (.066")	179 B/U 316 B/U	9.5 (.374")	5.9 (.232")	1.6 (.062")
plug	L17DM 53741-3	13.5 (.531")	18.6 (.732")	2.8 (.110")	180 B/U	10.7 (.421")	7.9 (.311")	2.4 (.094")
plug	L17DM 53741-4	13.5 (.531")	18.6 (.732")	3.2 (.126")	58 C/U	10.7 (.421")	7.9 (.311")	2.4 (.094")
socket	L17DM 53743-2	13.5 (.531")	18.6 (.732")	1.0 (.039")	178 B/U	9.5 (.374")	5.9 (.232")	1.6 (.062")
socket	L17DM 53743-3	13.5 (.531")	18.6 (.732")	1.7 (.066")	179 B/U 316 B/U	9.5 (.374")	5.9 (.232")	1.6 (.062")
socket	L17DM 53743-5	13.5 (.531")	18.6 (.732")	2.8 (.110")	180 B/U	10.7 (.421")	7.9 (.311")	2.4 (.094")
socket	L17DM 53743-6	13.5 (.531")	18.6 (.732")	3.2 (.126")	58 C/U	10.7 (.421")	7.9 (.311")	2.4 (.094")

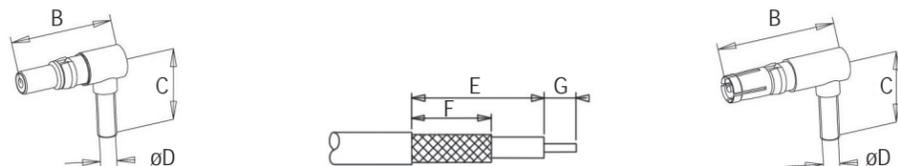
**Ferrule and inner solder**

Type	P/N	Dimensions (inch)			Cable - RG	Trim dimensions (inch)		
		A Max	B	D		E	F	G
plug	L17DM 53741-5000	13.5 (.531")	18.6 (.732")	1.0 (.039")	178 B/U	9.5 (.374")	5.9 (.232")	1.6 (.062")
plug	L17DM 53741-5001	13.5 (.531")	18.6 (.732")	1.7 (.066")	179 B/U 316 B/U	9.5 (.374")	5.9 (.232")	1.6 (.062")
plug	L17DM 53741-5003	13.5 (.531")	18.6 (.732")	2.8 (.110")	180 B/U	10.7 (.421")	7.9 (.311")	2.4 (.094")
plug	L17DM 53741-5004	13.5 (.531")	18.6 (.732")	3.2 (.126")	58 C/U	10.7 (.421")	7.9 (.311")	2.4 (.094")
socket	L17DM 53743-5000	13.5 (.531")	18.6 (.732")	1.0 (.039")	178 B/U	9.5 (.374")	5.9 (.232")	1.6 (.062")
socket	L17DM 53743-5001	13.5 (.531")	18.6 (.732")	1.7 (.066")	179 B/U 316 B/U	9.5 (.374")	5.9 (.232")	1.6 (.062")
socket	L17DM 53743-5003	13.5 (.531")	18.6 (.732")	2.8 (.110")	180 B/U	10.7 (.421")	7.9 (.311")	2.4 (.094")
socket	L17DM 53743-5004	13.5 (.531")	18.6 (.732")	3.2 (.126")	58 C/U	10.7 (.421")	7.9 (.311")	2.4 (.094")

**Crimping tool****Hand crimp tool**

227-0944 (without dies) (M 22 520/5-01)

RG cables	MIL reference	Amphenol P/N	dim. between 2 flat surface	
			cavity A	cavity B
RG 58 C/U	M 22 520/5-05	227 1221-05	5.41	-
RG 178 B/U	M 22 520/5-03	227 1221-03	-	2.67
RG 179 B/U	M 22 520/5-03	227 1221-03	3.25	-
RG 180 B/U	M 22 520/5-05	227 1221-05	-	4.52

**Extraction tool**Extraction tool for sizes 8 cts  
L17D429SP



**Straight crimp shielded contacts:**

*inner solder contact  
outer crimp contact*

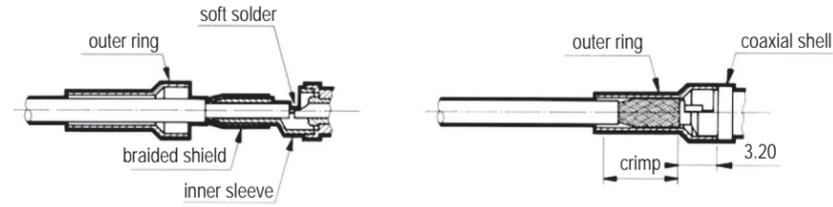

**Right angle crimp shielded contacts:**

*inner solder contact  
outer crimp contact*

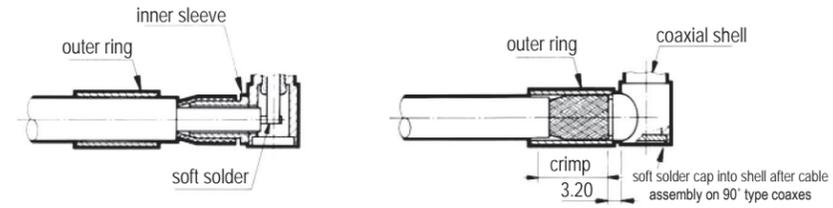

**Assembly method**

- Slide the outer ring over the cable jacket. Trim the cable according to the recommended dimensions.
- Insert the cable dielectric and the center conductor inside the inner sleeve.
- Solder the central conductor to the shielded center contacts.
- Slide the outer ring towards the inner sleeve and recover the braid.
- Using crimp hand tool equipped with the appropriate dies, crimp in the area defined.

**Solder straight shielded contacts:**

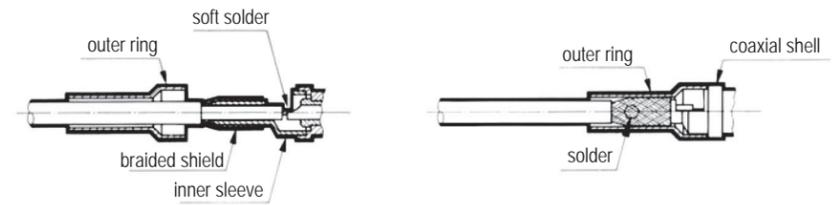

**Solder right angle shielded contacts:**

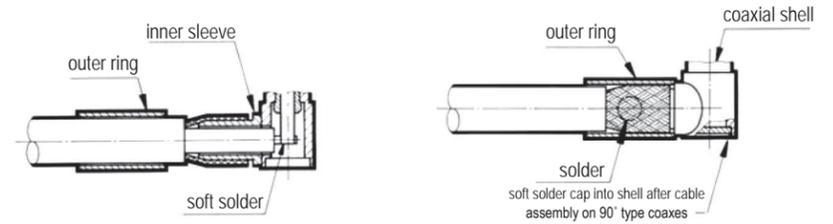

**Assembly method**

- Slide the outer ring over the cable jacket. Trim the cable according to the recommended dimensions.
- Insert the cable dielectric and the center conductor inside the inner sleeve.
- Solder the central conductor to the shielded center contacts.
- Slide the outer ring towards the inner sleeve and recover the braid.
- Solder by introducing metal through the outer ring hole.

**L**

**RoHS Compliant**

**Contacts and Shell**

Contact Plating	Shell	
	Tinned	Tinned & Indents; Plug only
0.4µm(16µ") Au	77	717
0.76µm(30µ") Au	177	777

**Shell size and Configuration:**  
E5W1, A3W3, A7W2, A11W1, B5W5, B9W4, B13W3, B17W2, B21W1, C8W8, C13W6, C17W5, C21WA4, C25W3, C27W2, D24W7, D36W4, D43W2

**Gender:**  
P: Pin  
S: Socket

**Contacts:**

**For straight**

BLANK: Solder-cup signal contacts only  
P3SY: 20-40 Amp power & signal mix  
P2SY: 10-20 Amp power & signal mix  
CSY: Coax & signal mix  
SY: Signal only  
P3Y: 20-40 Amp power only (3W3, 5W5, 8W8)  
P2Y: 10-20 Amp power only (3W3, 5W5, 8W8)  
CY: Coax only (3W3, 5W5, 8W8)

**For right angle**

MP3SV: US Footprint, 20-40 Amp power & signal mix  
MP2SV: US Footprint, 10-20 Amp power & signal mix  
MCSV: US Footprint, Coax & signal mix  
MSV: US Footprint, Signal only  
MP3V: US Footprint, 20-40 Amp power only (3W3, 5W5, 8W8)  
MP2V: US Footprint, 10-20 Amp power only (3W3, 5W5, 8W8)  
MCV: US Footprint, Coax only (3W3, 5W5, 8W8)  
EP3SV: European Footprint, 20-40 Amp power & signal mix  
EP2SV: European Footprint, 10-20 Amp power & signal mix  
ESV: European Footprint, Signal only  
EP3V: European Footprint, 20-40 Amp power only (3W3, 5W5, 8W8)  
EP2V: European Footprint, 10-20 Amp power only (3W3, 5W5, 8W8)  
HP3SV: Mixed Footprint, 20-40 Amp power & signal mix  
HP2SV: Mixed Footprint, 10-20 Amp power & signal mix  
HCSV: Mixed Footprint, Coax & signal mix  
HSV: Mixed Footprint, Signal only  
HP3V: Mixed Footprint, 20-40 Amp power only (3W3, 5W5, 8W8)  
HP2V: Mixed Footprint, 10-20 Amp power only (3W3, 5W5, 8W8)  
HCV: Mixed Footprint, Coax only (3W3, 5W5, 8W8)

**... TW ...**

**Special Deviations**  
Please consult factory

**Board Mounting Options**

**For Straight**  
Blank: .120"(3.05mm) Clear Hole  
RM53: M3 Threaded (panel side)  
standoff with boardlock  
RM54: 4-40UNC Threaded (panel side)  
standoff with boardlock  
RM84: Non-Removable M3 screwlock,  
with standoff and boardlock

**For Right Angle**  
RM6: Metal bracket with boardlocks

**Panel Mounting Options**

**For right angle & cable mount**  
Blank: .120"(3.05mm) Clear Hole  
3F: M3 Front Screwlock  
3R: M3 Rear Threaded Insert  
4F: #4-40 Front Screwlock  
4R: #4-40 Threaded Rear Insert  
FM: Float mount system  
A514: Blind Mate Guide Pin





## SURFACE MOUNT CONNECTORS

CHARACTERISTICS

### Specifications

- Connectors according to MIL C24308 - NFC 93425-HE5

Materials and Platings	
<b>Shells</b>	Steel with tin plating
<b>Insulator</b>	High temperature (peak at 260°C) glass-filled thermoplastic, UL 94V-0
<b>Socket contact</b>	Stamped and formed brass, selected gold in mating area; 2.54µm (100µ") min. tin on termination area, with entire contact under-plated 1.27µm (50µ") min. nickel
<b>Rear insert</b>	Brass, 3µm up to 5µm (118µ" up to 197µ") tinned over nickel 2µm up to 3µm (78µ" to 118µ")
<b>Boardlock</b>	Tin plating 4µm up to 6µm (157µ" up to 236µ") over nickel 2µm up to 3µm (78µ" up to 118µ"), insertion force: Low Insertion Force = LIF (bronze) Zero Insertion Force = ZeFo (bronze)
<b>Screwlock</b>	Brass, 6µm up to 10µm (236µ" up to 394µ") tinned over nickel 2µm up to 3µm (78µ" up to 118µ")
<b>Grounding</b>	Grounding strap: brass, 4µm up to 6µm tin plating over nickel 2µm up to 3µm (78µ" up to 118µ")

Electrical Data	
<b>Current rating</b>	3A
<b>Voltage rating</b>	300V AC/rms 50Hz
<b>Withstanding voltage</b>	1000V AC/rms 50Hz for one minute
<b>Insulation resistance</b>	5000MΩ
<b>Contact resistance</b>	10mΩ max

Climatic Data	
<b>Operating temperature</b>	85°C, peak at 105°C
<b>Damp heat</b>	56 days (40°C - 95% HR)

Mechanical Data	
<b>Single contact insertion force</b>	1.2N < F < 2.5N
<b>Single contact withdrawal force</b>	0.4N min
<b>LIF boardlock</b>	8N max per connector
<b>Coplanarity of contacts</b>	0.2mm (.008") max

**Mating and unmating force**  
Unit: N

No. of Cts	Mate (max)	Unmate (min)
9 (size E)	30	3.5
15 (size A)	50	4.5
25 (size B)	83	8.0

DESCRIPTION

Amphenol SMT D-Sub is offered in right angle, receptacle with brackets, as an industry standard for I / O connections.

Boardlock features:

-LIF (Low Insertion Force) boardlock especially designed to be fully compatible with pick and place machine.

-ZeFo (Zero Force Insertion) boardlock has been designed so that once placed and expanded, secures a safe locking.

*Designed for  
Pick and Place  
SMT process*

APPLICATIONS

- Industrial
- Telecom
- Any industry standard I / O connections

SM2 / E2

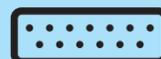

Amphenol

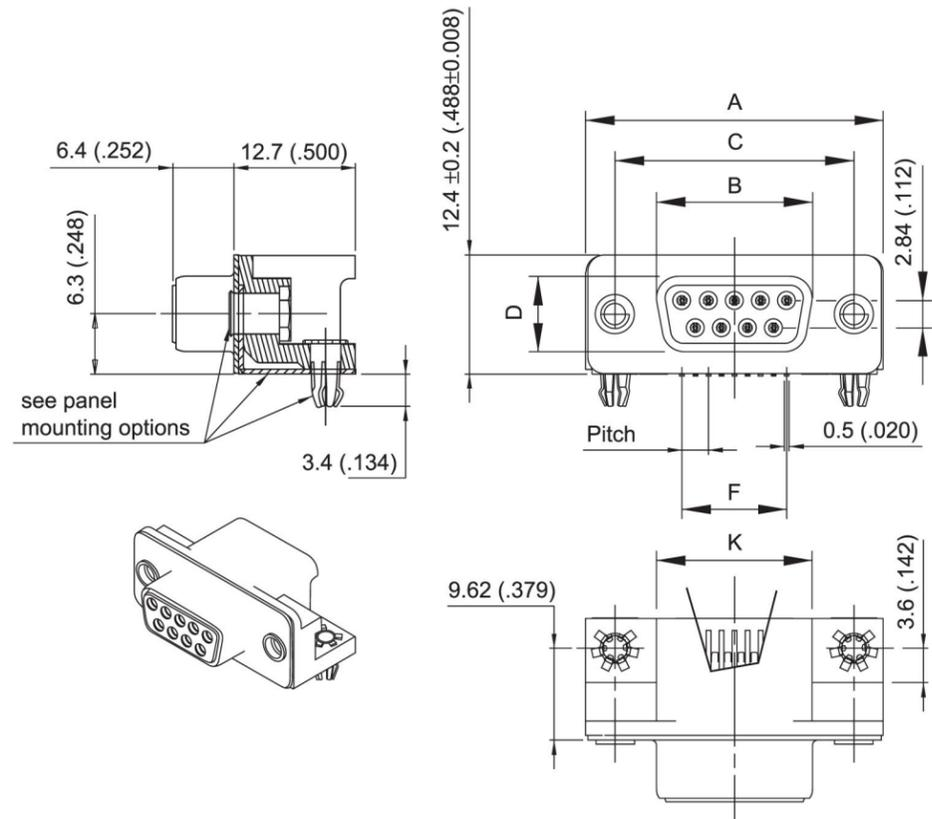

PCB LAYOUT

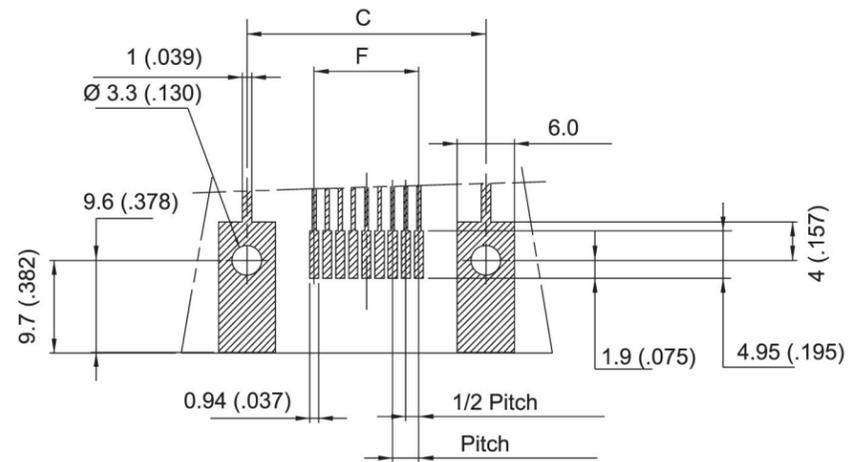

SHELL SIZE	mm (inch)						
	A	B	C	D	PITCH	F	K
	+0.05 (.002) -0.1 (.004)	0 -0.2 (.008)	±0.1 (.004)	0 -0.25 (.01)			
E	31.15 (1.226)	16.4 (.645)	25 (.984)	8.03 (.316)	2.74 (.1078)	10.97 (.432)	16.3 (.642)
A	39.4 (1.551)	24.8 (.976)	33.3 (1.311)	8.03 (.316)	2.74 (.1078)	19.2 (.756)	24.6 (.968)
B	53.3 (2.098)	38.5 (1.515)	47 (1.850)	8.03 (.316)	2.76 (.1086)	33.12 (1.304)	38.3 (1.508)

**GROUNDING TABS:**

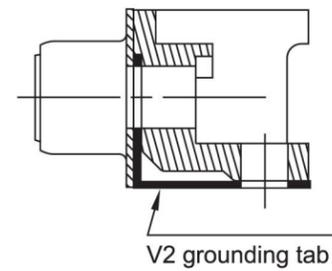
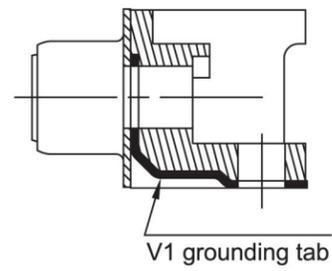

**BOARDLOCKS:**

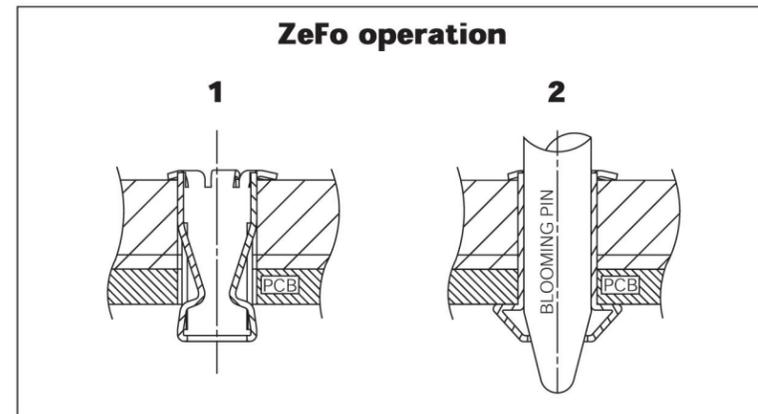
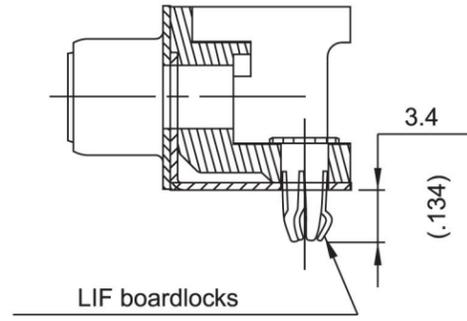
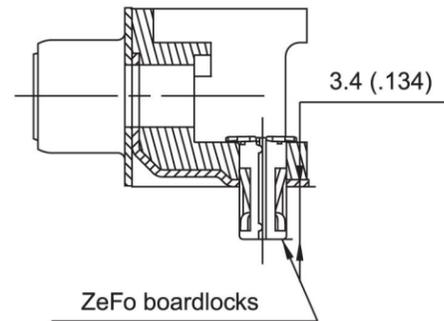

**FLANGES ACCESSORIES:**

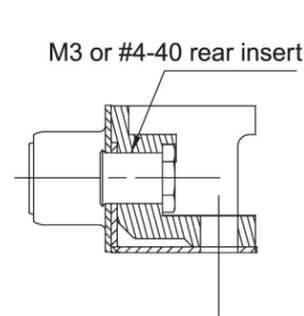

Threaded Rear

**1/2**

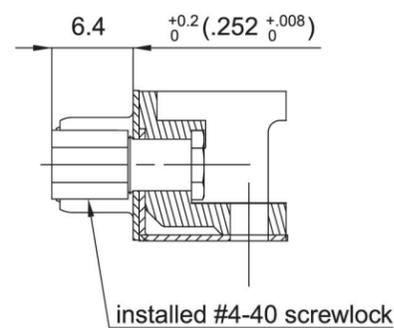

Installed Front Female

**5**

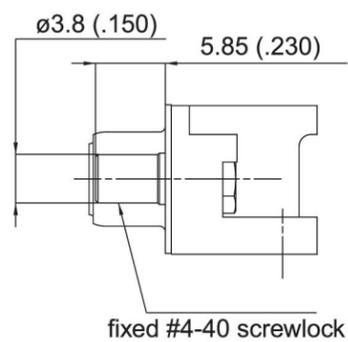

Fixed Front Female

**6**

How to order

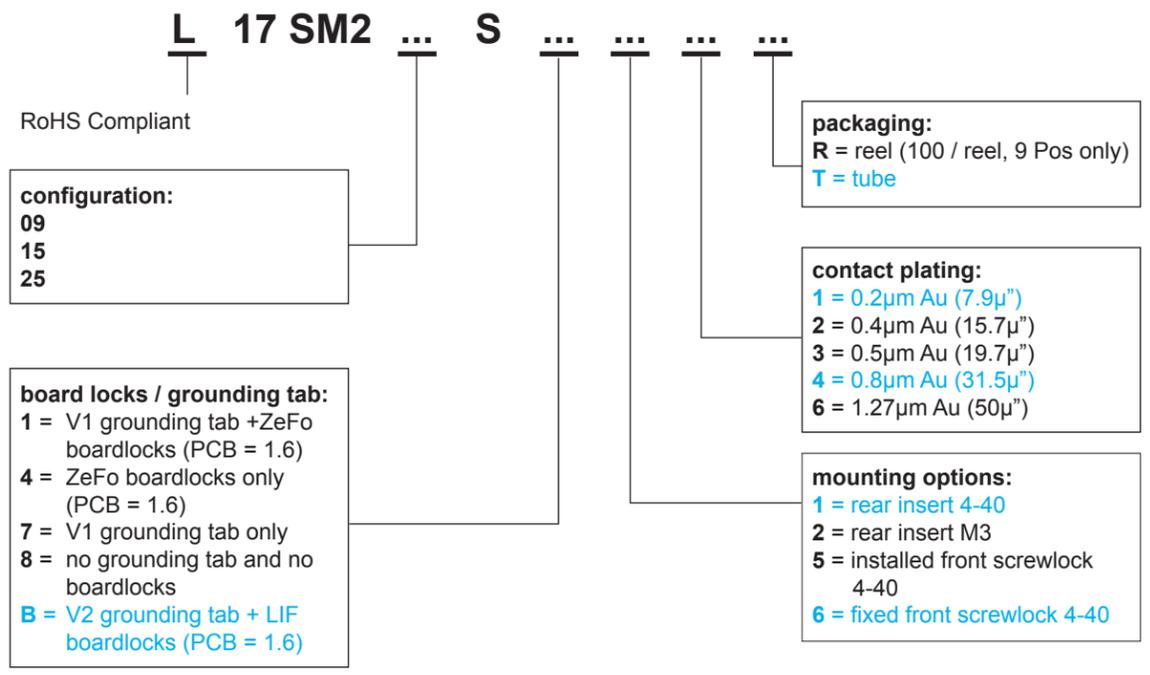

■ : Standard options

*For special request, please consult factory*

**Memo**

---



---



---



---



---



---



---



---



---



---



---



---



---



---



---



---



---



---



---



---



---



---

**Do not hesitate to contact us for further information**

**Amphenol**  
**Amphenol IT & Communication Products**  
 Block A3/A4, The 4th Industrial District of  
 Industrial Headquarters, Dong Keng Road  
 Gong Ming Town, Shen Zhen China  
 Fax:+86(0)755 2754 9955  
**Technical Support**  
 Tel:+86(0)755 2717 7945  
 Info-dsub@amphenol.com.cn  
<http://www.dsubconnector.com>

# D-ST

## Screw Termination D'Sub series



CHARACTERISTICS

- Connectors according to: MIL C24308 - NFC 93425-HE5

Materials and platings	
Shells	Steel, Tin plated
Insulator	Glass filled thermoplastic, UL 94V-0
Contacts	Machined brass for plug full gold Machined bronze for socket, full gold

Electrical Data	
Current rating	7,5 A max
Voltage rating	300 V RMS at 50 Hz
Withstanding voltage	1000 V RMS at 50 Hz
Insulation resistance	> 5000 MΩ at 500 V DC
Contact resistance	< 5 mΩ

Climatic Data	
Operating temperature	- 55°C to + 85°C, peak at 125°C
Damp heat	21 days (40°C - 95% HR)
Salt spray	48 hours

Mechanical Data	
Cable type	Solid or stranded
Cable gage	0.75 mm max ( AWG 18 ) - For bigger wire, please consult factory
Screw torque	0.05 mN max
Mating cycles	100 (class II) or 500 (class I)

DESCRIPTION

The Amphenol Screw Termination D'Sub series is especially designed for field applications.

These new connectors permit easy wiring without any specific tool : Just a standard electrician's screwdriver is required.

Due to their reduced overall dimensions, these connectors are compatible with all standard hoods and accessories

*Simplify  
Your cable  
assemblies!*

APPLICATIONS

- Industry control of speed variators,
- Houses and public buildings control of heating, air conditioning, lighting, shutters, fire safety...
- Infrastructures fluids control, motorway

D-ST / E3



Amphenol

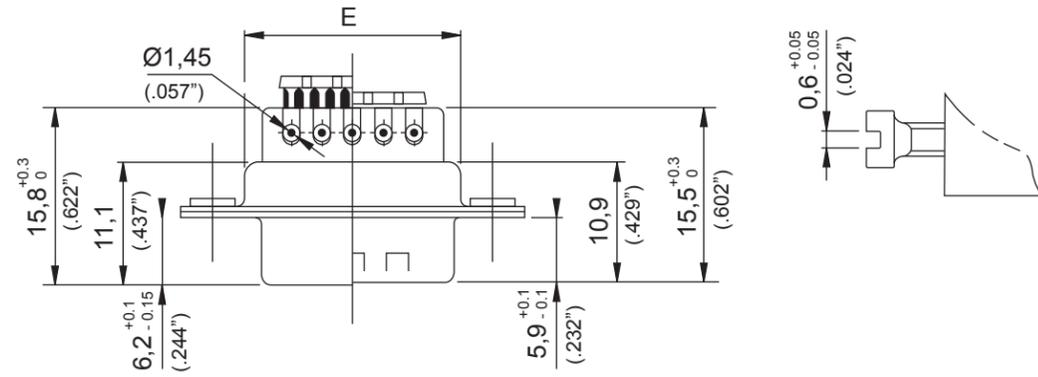
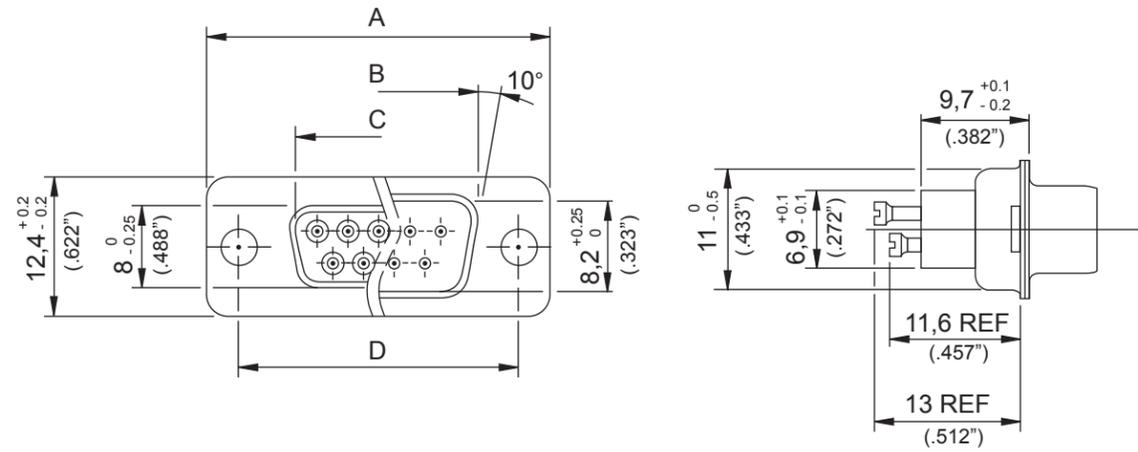

**Cable stripping**

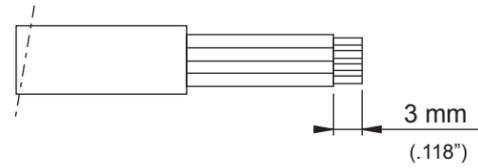

SIZE	A +0,25 (.010") -0,25 (.010")	B 0 -0,2 (.008")	C +0,2 (.008") 0	D +0,1 (.004") -0,1 (.004")	E +0,1 (.004") -0,4 (.016")
<b>9</b>	30.7 (1.209")	16.4 (.646")	16.8 (.661")	25 (.984")	19.4 (.370")
<b>15</b>	39 (1.535")	24.8 (.976")	25.1 (.988")	33.3 (1.311")	27.7 (1.091")
<b>25</b>	52.9 (2.083")	38.5 (1.516")	38.8 (1.528")	47 (1.850")	41.4 (1.630")
<b>37</b>	69.2 (2.724")	54.9 (2.161")	55.3 (2.177")	63.5 (2.500")	57.9 (2.280")



**L 717D E09 P ST 1**

Class II:	77D	Female connector
	717D	Male connector, shells with dimples
Class I:	177D	Female connector
	777D	Male connector, shells with dimples

RoHS Compliant

Size and number of contacts      **E09, A15, B25, C37**

Type of contact:      **P = Male      S = Female**

Contact termination:      **ST = Screw termination**

Kit connector + hood option:  
(See following description)

- 1 = DPPK hood**
- 2 = DSSK hood**
- 3 = DTZK hood**
- 4 = DVZK hood**

**Plastic hoods**



DPPK Straight cable entry

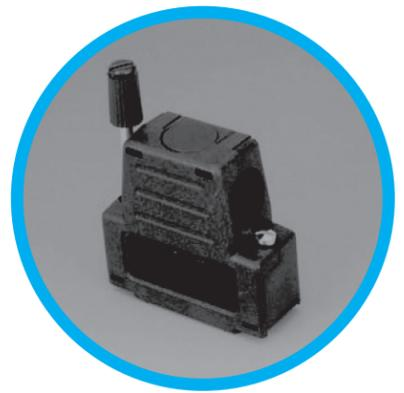

DSSK Angled cable entry

**Metallic hoods**



DTZK Straight cable entry

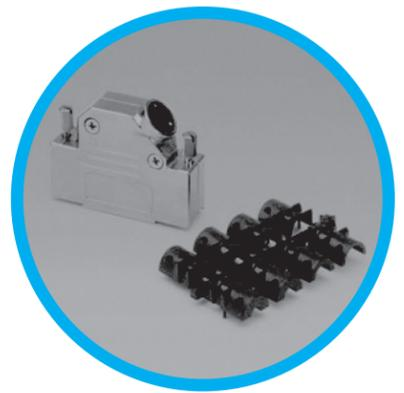

DVZK Angled cable entry

**D-ST / E3**



# TF

D-Sub connectors - Stamped and Formed Contacts

## PRESS FIT STRAIGHT PCB TERMINATION



CHARACTERISTICS

Materials and Platings	
<b>Shells</b>	Steel, tin plated
<b>Insulator</b>	Glass-filled thermoplastic, UL 94V-0
<b>Pin contact</b>	Brass, selected gold in mating area; 2.54µm (100µ") min. tin on termination area over 1.27µm (50µ") min. nickel
<b>Socket contact</b>	Phosphor bronze, selected gold in mating area; 2.54µm (100µ") min. tin on termination area over; 1.27µm(50µ") min. nickel
<b>Rear insert</b>	Brass, 2.54µm (100µ") min. nickel plated
<b>Boardlock</b>	Brass, 2.54µm (100µ") min. nickel plated
<b>Screwlock</b>	Brass, 2.54µm (100µ") min. nickel plated

Electrical Data	
<b>Current rating</b>	3A
<b>Voltage rating</b>	300V AC
<b>Withstanding voltage</b>	1000V AC/rms 60Hz for one minute
<b>Insulation resistance</b>	1000MΩ
<b>Contact resistance</b>	25mΩ max

Climatic Data	
<b>Operating temperature</b>	-55°C to +125°C
<b>Salt spray</b>	24 hours

Mechanical Data	
<b>Single contact insertion force</b>	≤ 3.60 N
<b>Single contact withdrawal force</b>	≥ 0.2 N
<b>Single contact insertion on board</b>	≤ 100 N
<b>Single contact withdrawal from board</b>	≥ 20 N
<b>Standard plating thickness</b>	Gold flash 0.4µm (15µ") gold 0.76µm (30µ") gold

	Terminal Specification	Boardlock Specification
<b>Finished Hole</b>	1 (+0.09 -0.06)	3.1 +/- 0.05 mm
<b>Cu</b>	> 25 µm	Min 25 µm
<b>Sn</b>	< 15 µm	5-15 µm

DESCRIPTION

The Amphenol "TF" series features eye of needle formed contacts, and insulator with closed entry contacts cavities.

This series gives you Amphenol's high standards of quality and reliability to meet all your technical requirements.

*Solderless  
straight PCB  
mount  
connectors*

APPLICATIONS

- Industrial
- Telecom
- Any backplanes connections

TF / E4

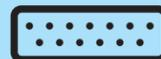

Amphenol

Socket version

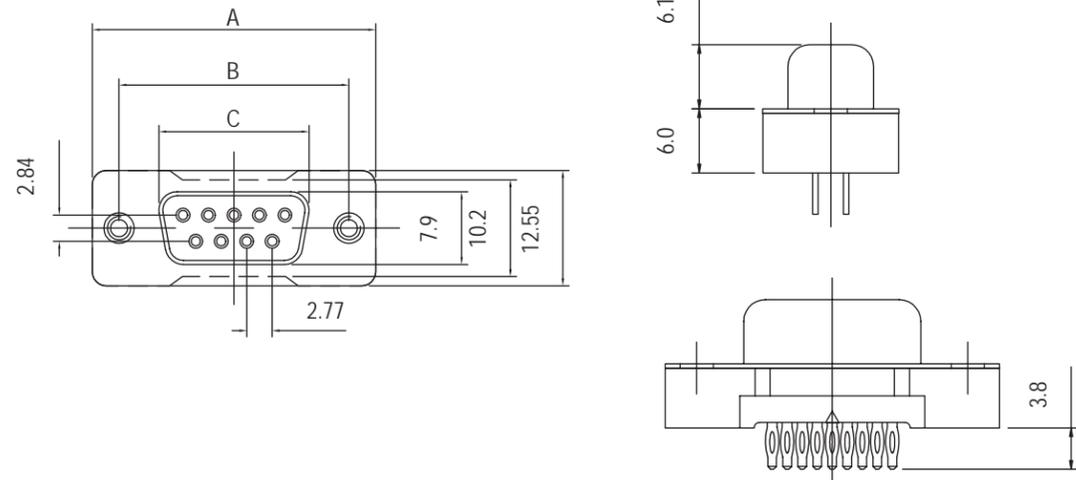

Plug version

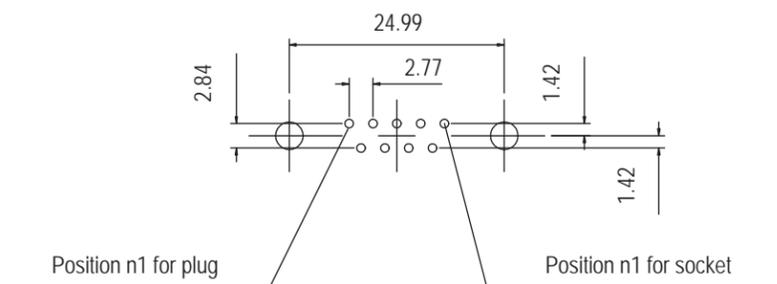
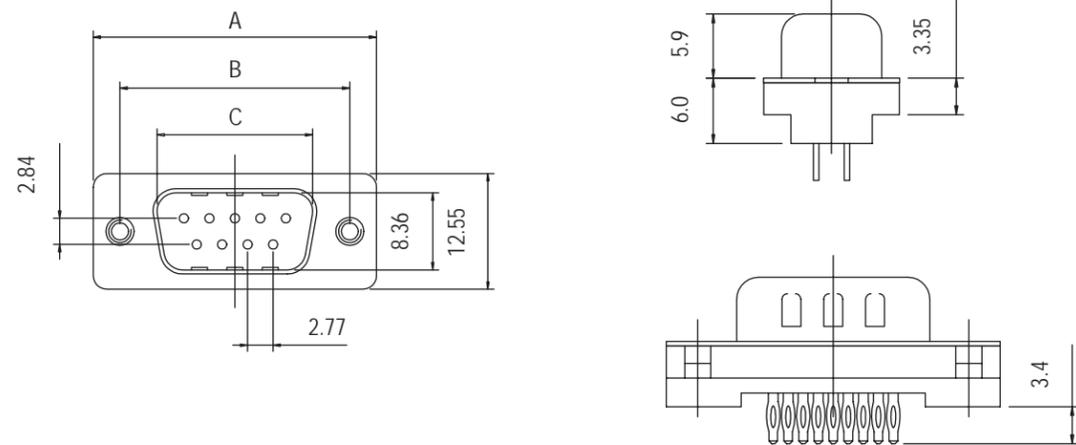

For PCB holes diameters, see on page 1 (finished holes)

Nb OF CONTACTS	DIMENSIONS mm (inch)			
	A	B	C plug	C socket
9	30.81 (1.185)	24.99 (0.984)	16.92 (0.666)	16.33 (0.643)
15	39.14 (1.54)	33.32 (1.312)	25.50 (1.004)	24.66 (0.97)
25	53.04 (2.088)	47.04 (1.852)	28.96 (1.534)	38.38 (1.511)
37	69.32 (2.729)	63.50 (2.5)	55.42 (2.182)	54.84 (2.16)

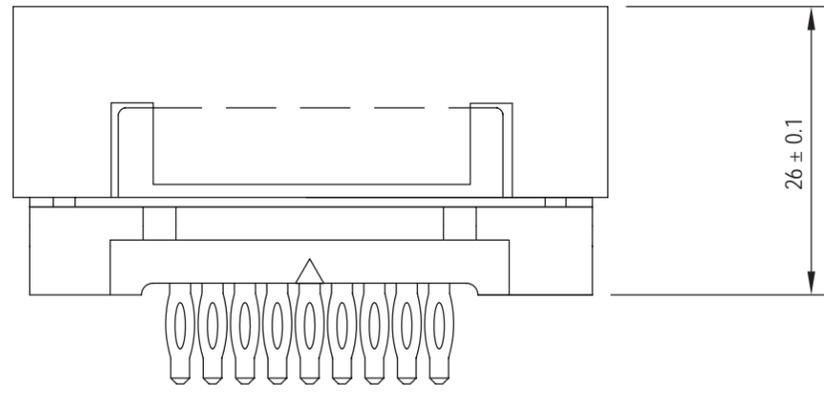

*Female*

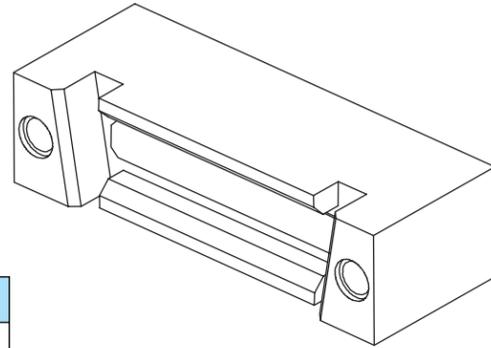

Size of connectors	Tooling PN
9	981 MC
15	982 MC
25	983 MC
37	984 MC

*Male*

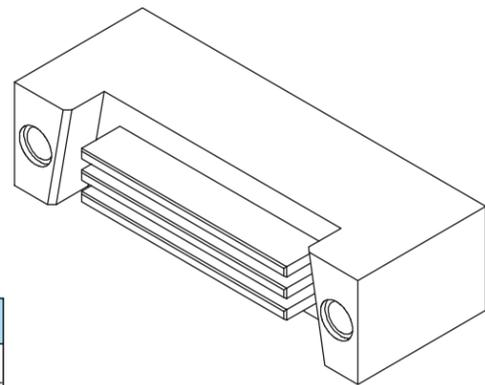

Size of connectors	Tooling PN
9	985 MC
15	986 MC
25	987 MC
37	988 MC

PRESS-FIT TOOLING

TF/E4



## Board mounting option

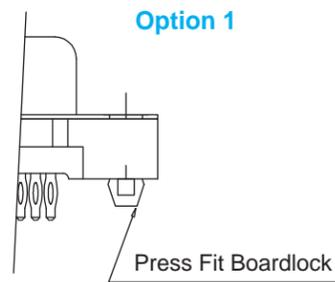
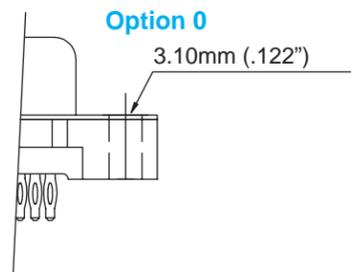

## Flange mounting option

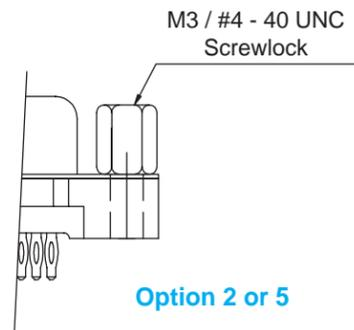
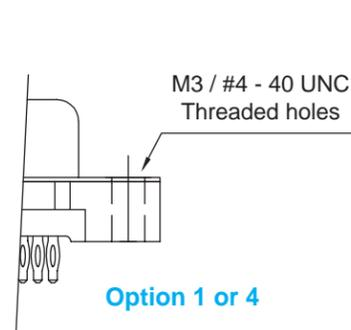

## How to order

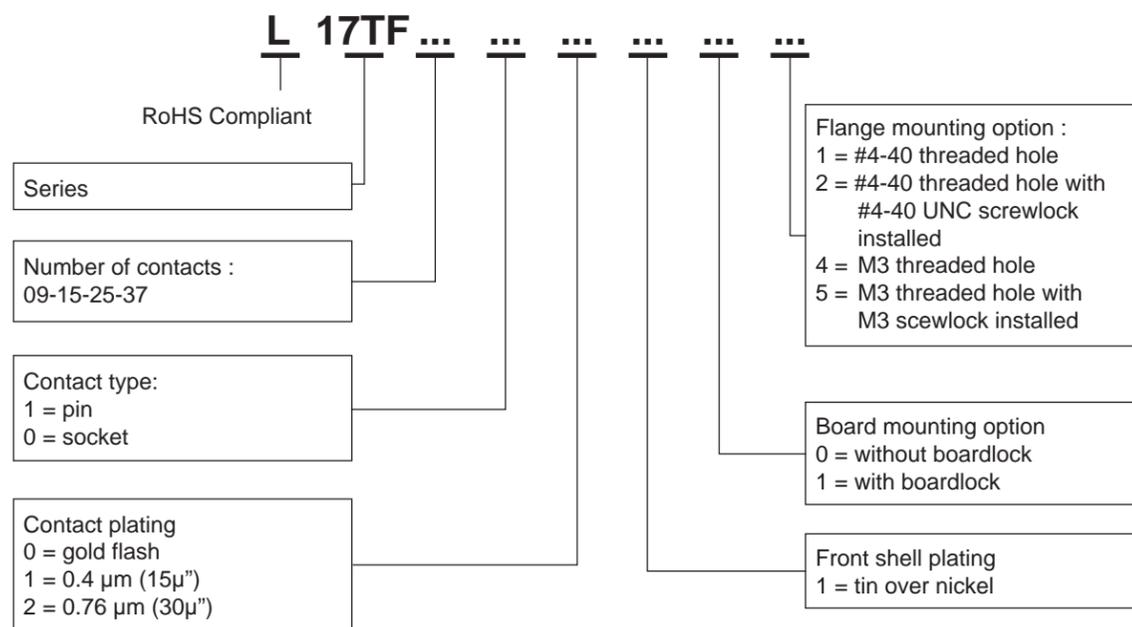

Do not hesitate to contact us for further information

# Amphenol

## Amphenol IT & Communication Products

Block A3/A4, The 4th Industrial District of  
Industrial Headquarters, Dong Keng Road  
Gong Ming Town, Shen Zhen China  
Fax: +86(0)755 2754 9955

### Technical Support

Tel: +86(0)755 2717 7945  
Info-dsub@amphenol.com.cn  
<http://www.dsubconnector.com>

# SD

D'Sub connectors - Stamped and Formed Contacts

## SOLDER-CUP TERMINATION STANDARD and HIGH DENSITY



CHARACTERISTICS

### Specifications

- Connectors according to: MIL C24308 - NFC 93425-HE5

Materials and Platings	
<b>Shells</b>	Steel, tin over nickel plating
<b>Insulator</b>	Glass-filled thermoplastic, UL 94V-0
<b>Pin contacts</b>	Brass, selected gold in mating area; 2.54µm (100µ") min. tin on termination area over 1.27µm (50µ") min. nickel
<b>Socket contact</b>	Phosphor bronze, selected gold in mating area; 2.54µm (100µ") min. tin-on termination area over 1.27µm (50µ") min. nickel
<b>Rear insert</b>	Brass, 2.54µm (100µ") min. nickel plated
<b>Screwlock</b>	Brass, 2.54µm (100µ") min. nickel plated

Electrical Data	
<b>Current rating</b>	Standard Density: 5A High Density: 3A
<b>Voltage rating</b>	250V AC/rms 50Hz
<b>Withstanding voltage</b>	1000V AC/rms 50Hz for one minute
<b>Insulation resistance</b>	1000MΩ at 500V DC
<b>Contact resistance</b>	20mΩ max

Climatic Data	
<b>Operating temperature</b>	-55°C to +125°C
<b>Salt spray</b>	24 hours

Mechanical Data					
<b>Single contact insertion force</b>		0.54kg (1.19lb) max			
<b>Single contact withdrawal force</b>		SD : 0.06kg (0.13lb) min HD : 0.02kg (0.044lb) min			
<b>Mating and unmating force</b>					
Unit: kg ( lb)					
No. of Cts		SD		HD	
SD	HD	Mate (max)	Unmate (min)	Mate (max)	Unmate (min)
9	15	3.05 (6.74)	0.36 (0.79)	3.81 (8.42)	0.52 (1.14)
15	26	5.09 (11.24)	0.46 (1.01)	5.95 (13.16)	1.05 (2.32)
25	44	8.44 (18.66)	0.81 (1.8)	9.26 (20.46)	1.37 (3.02)
37	62	12.51 (27.65)	1.1 (2.47)	13.48 (29.78)	1.76 (3.88)
50	78	14.65 (32.38)	1.6 (3.56)	15.82 (34.96)	2.02 (4.46)
<b>Standard plating thickness</b>		<ul style="list-style-type: none"> <li>gold flash</li> <li>0.4µm (15µ") gold</li> <li>0.76 µm (30µ") gold</li> </ul>			

DESCRIPTION

The Amphenol "SD" series features precision formed contacts, and insulator with closed entry contacts cavities.

This series gives you Amphenol's high standards of quality and reliability to meet all of your commercial requirements.

*Economical  
solder cup  
connectors*

APPLICATIONS

- Industrial
- Telecom
- Any industry standard I/O connections

SD / E5

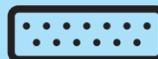

Amphenol

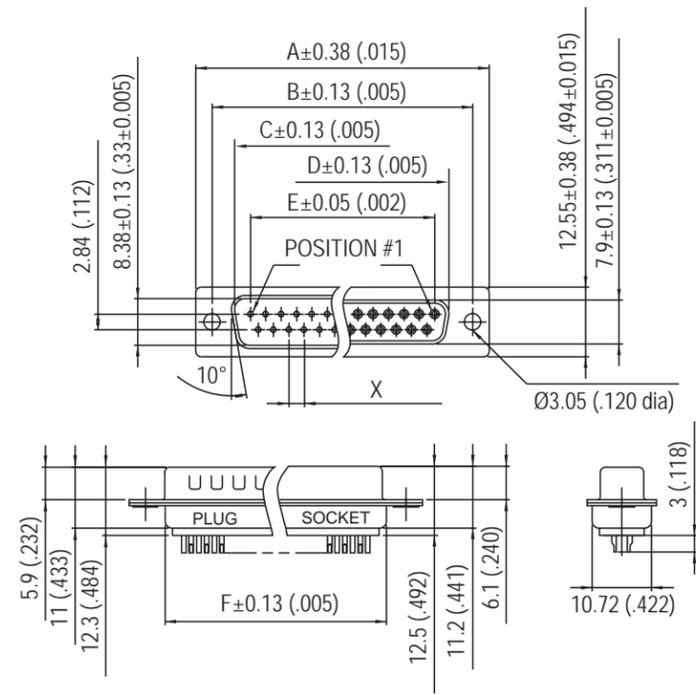

Nb OF CONTACTS	DIMENSIONS mm (inch)						
	A	B	C	D	E	F	X
9	30.84 (1.21)	24.99 (.98)	16.92 (.67)	16.24 (.64)	11.09 (.44)	19.28 (.76)	2.74
15	39.24 (1.54)	33.32 (1.31)	24.7 (.972)	24.56 (.97)	19.39 (.76)	27.51 (1.08)	2.74
25	53.04 (2.09)	47.04 (1.85)	38.96 (1.53)	38.38 (1.51)	33.24 (1.31)	41.30 (1.63)	2.77
37	69.32 (2.73)	63.50 (2.50)	55.42 (2.18)	54.76 (2.16)	49.86 (1.96)	57.71 (2.27)	2.77
50	67 (2.64)	61.11 (2.41)	52.86 (2.08)	52.34 (2.06)	44.32 (1.75)	55.3 (2.18)	2.77

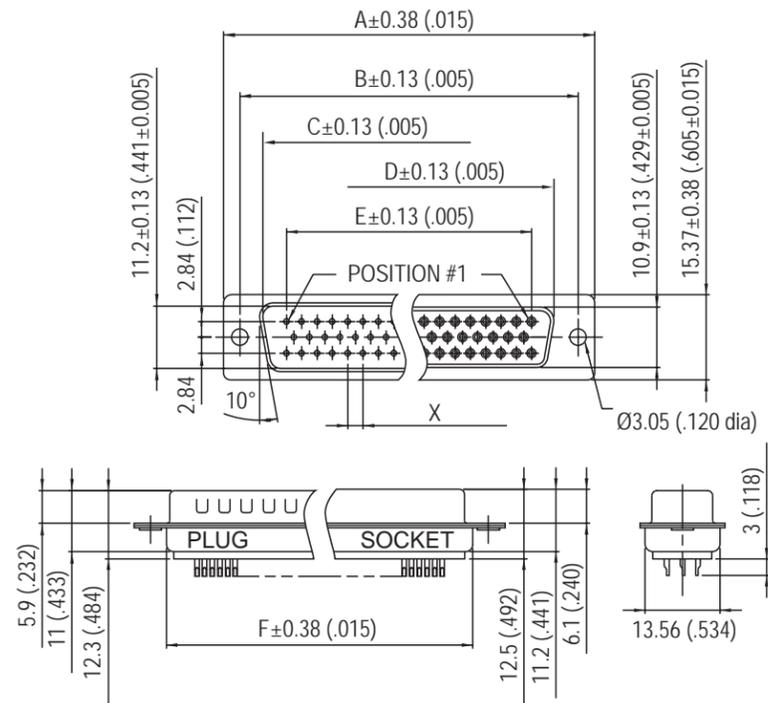

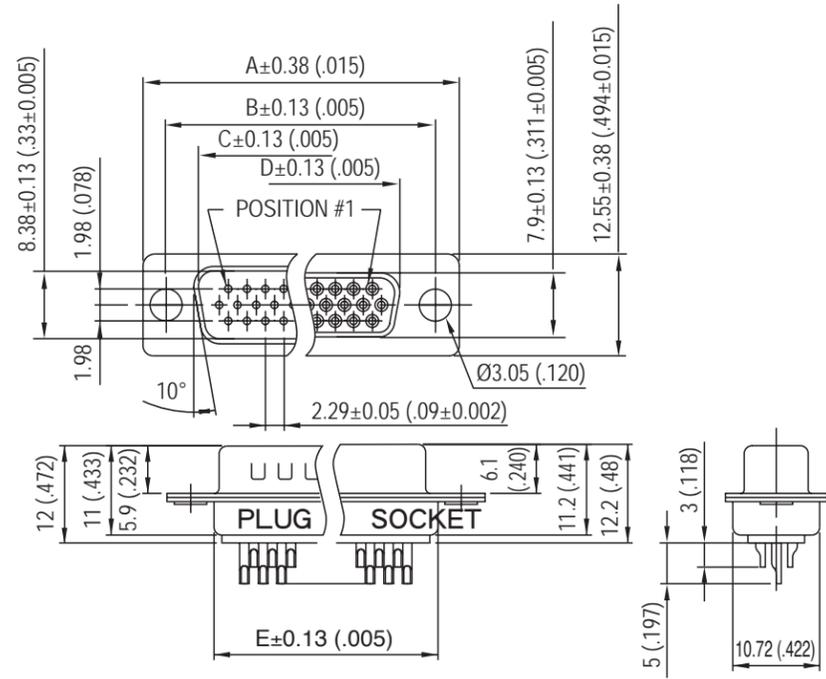

Nb OF CONTACTS	DIMENSIONS mm (inch)				
	A	B	C	D	E
15	30.84 (1.21)	24.99 (.98)	16.92 (.67)	16.24 (.64)	19.28 (.76)
26	39.24 (1.54)	33.32 (1.31)	24.7 (.972)	24.56 (.97)	27.51 (1.08)
44	53.04 (2.09)	47.04 (1.85)	38.96 (1.53)	38.38 (1.51)	41.30 (1.63)
62	69.32 (2.73)	63.50 (2.50)	55.42 (2.18)	54.76 (2.16)	57.71 (2.27)
78	67 (2.64)	61.11 (2.41)	52.86 (2.08)	52.34 (2.06)	55.3 (2.18)

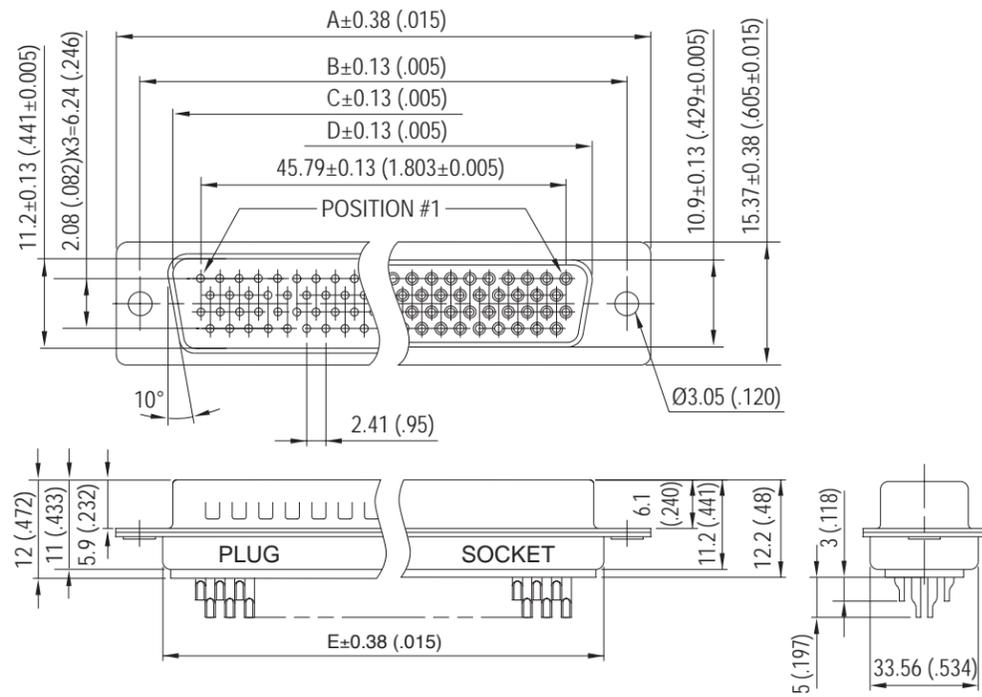

78 CONTACTS

OVERALL DIMENSION

SD / E5



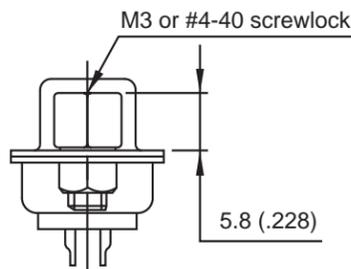

**Front Female Screwlock**  
VF / VFM

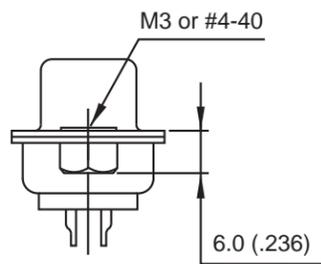

**Threaded Rear Insert**  
H / G

How to order

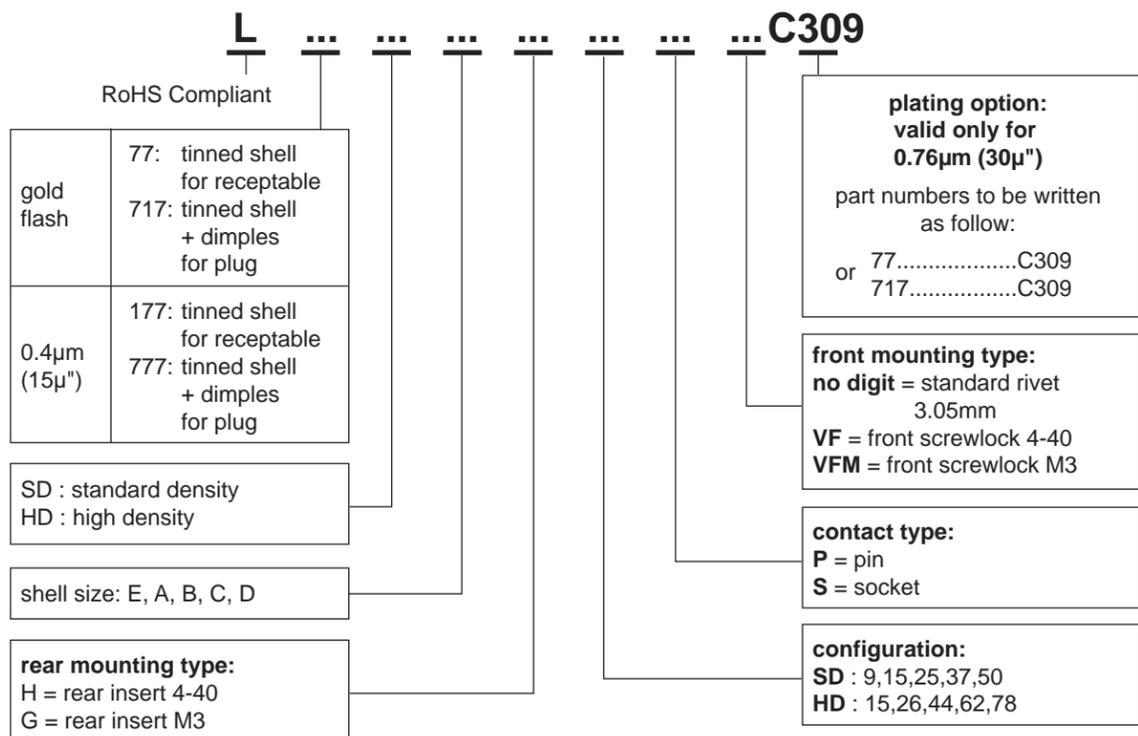

*For special request, please consult factory*

Do not hesitate to contact us for further information



# Amphenol

**Amphenol IT & Communication Products**

Block A3/A4, The 4th Industrial District of Industrial Headquarters, Dong Keng Road Gong Ming Town, Shen Zhen China  
Fax:+86(0)755 2754 9955

**Technical Support**

Tel:+86(0)755 2717 7945  
Info-dsub@amphenol.com.cn  
http://www.dsubconnector.com

# SD

D'Sub connectors - Stamped and Formed Contacts

## STRAIGHT PCB TERMINATION STANDARD and HIGH DENSITY

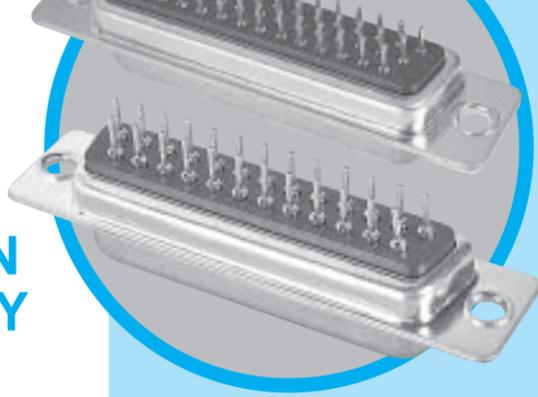

CHARACTERISTICS

### Specifications

- Connectors according to: MIL C24308 - NFC 93425-HE5

Materials and Platings	
<b>Shells</b>	Steel, tin over nickel plating
<b>Insulator</b>	Glass-filled thermoplastic, UL 94V- 0
<b>Pin contacts</b>	Brass, selected gold in mating area; 2.54µm (100 µ") min.tin on termination area over 1.27µm (50µ") min.nickel
<b>Socket contact</b>	Phosphor bronze, selected gold in mating area;2.54µ(100µ") min.tin on termination area over 1.27µm (50µ") min.nickel
<b>Rear insert</b>	Brass, 2.54µm (100µ") min.nickel plated
<b>Boardlock</b>	Brass, 2.54µm (100µ") min.nickel plated
<b>Screwlock</b>	Brass, 2.54µm (100µ") min.nickel plated (removable)

Electrical Data	
<b>Current rating</b>	Standard Density:5A High Density:3A
<b>Voltage rating</b>	250V AC/ rms 50Hz
<b>Withstanding voltage</b>	1000V AC/rms 50Hz for one minute
<b>Insulation resistance</b>	1000MΩ at 500V DC
<b>Contact resistance</b>	20mΩ max

Climatic Data	
<b>Operating temperature</b>	-55°C to +125°C
<b>Salt spray</b>	24 hours

Mechanical Data					
<b>Single contact insertion force</b>		0.54kg (1.19lb) max			
<b>Single contact withdrawal force</b>		SD : 0.06kg (0.13lb) min		HD : 0.02kg (0.044lb) min	
<b>Mating and unmating force</b>					
Unit: kg ( lb)					
No. of Cts		SD		HD	
SD	HD	Mate (max)	Unmate (min)	Mate (max)	Unmate (min)
9	15	3.05 (6.74)	0.36 (0.79)	3.81 (8.42)	0.52 (1.14)
15	26	5.09 (11.24)	0.46 (1.01)	5.95 (13.16)	1.05 (2.32)
25	44	8.44 (18.66)	0.81 (1.8)	9.26 (20.46)	1.37 (3.02)
37	62	12.51 (27.65)	1.1 (2.47)	13.48 (29.78)	1.76 (3.88)
50	78	14.65 (32.38)	1.6 (3.56)	15.82 (34.96)	2.02 (4.46)
<b>Standard plating thickness</b>		<ul style="list-style-type: none"> <li>gold flash</li> <li>0.381µm (15µ") gold</li> <li>0.76 µm (30µ") gold</li> </ul>			

DESCRIPTION

The Amphenol "SD" series features precision formed contacts, and insulator with closed entry contacts cavities. This series gives you Amphenol's high standards of quality and reliability to meet all of your commercial requirements.

*Economical  
straight PCB  
mount connectors*

APPLICATIONS

- Industrial
- Telecom
- Any industry standard I / O connections

SD / E6

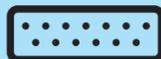

Amphenol

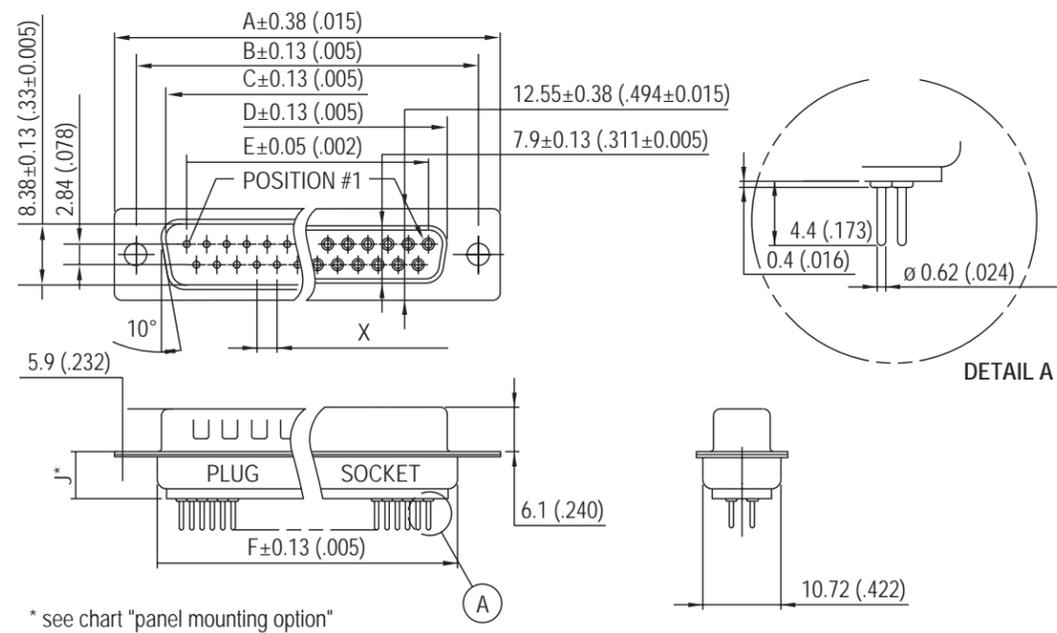

\* see chart "panel mounting option"

Nb OF CONTACTS	DIMENSIONS mm (inch)						
	A	B	C	D	E	F	X
9	30.84 (1.21)	24.99 (.98)	16.92 (.67)	16.24 (.64)	11.09 (.44)	19.28 (.76)	2.74
15	39.24 (1.54)	33.32 (1.31)	24.7 (.972)	24.56 (.97)	19.39 (.76)	27.51 (1.08)	2.74
25	53.04 (2.09)	47.04 (1.85)	38.96 (1.53)	38.38 (1.51)	33.24 (1.31)	41.30 (1.63)	2.77
37	69.32 (2.73)	63.50 (2.50)	55.42 (2.18)	54.76 (2.16)	49.86 (1.96)	57.71 (2.27)	2.77
50	67 (2.64)	61.11 (2.41)	52.86 (2.08)	52.34 (2.06)	44.32 (1.75)	55.3 (2.18)	2.77

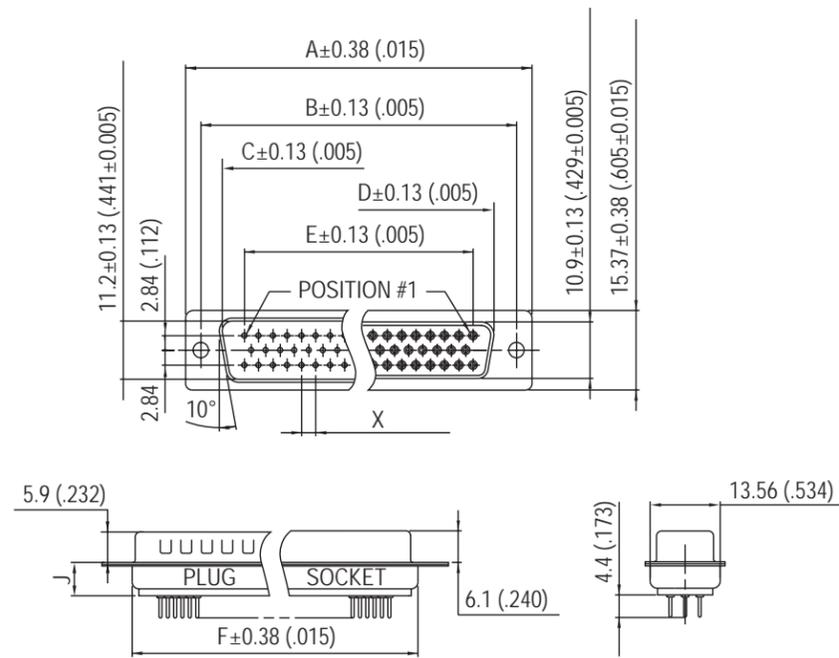

50 CONTACTS

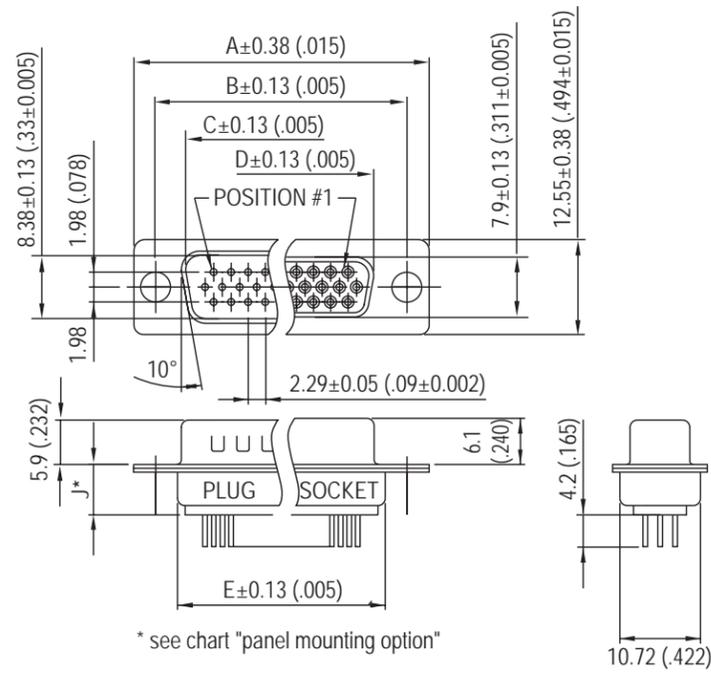

Nb OF CONTACTS	DIMENSIONS mm (inch)				
	A	B	C	D	E
15	30.84 (1.21)	24.99 (.98)	16.92 (.67)	16.24 (.64)	19.28 (.76)
26	39.24 (1.54)	33.32 (1.31)	24.7 (.972)	24.56 (.97)	27.51 (1.08)
44	53.04 (2.09)	47.04 (1.85)	38.96 (1.53)	38.38 (1.51)	41.30 (1.63)
62	69.32 (2.73)	63.50 (2.50)	55.42 (2.18)	54.76 (2.16)	57.71 (2.27)
78	67 (2.64)	61.11 (2.41)	52.86 (2.08)	52.34 (2.06)	55.3 (2.18)

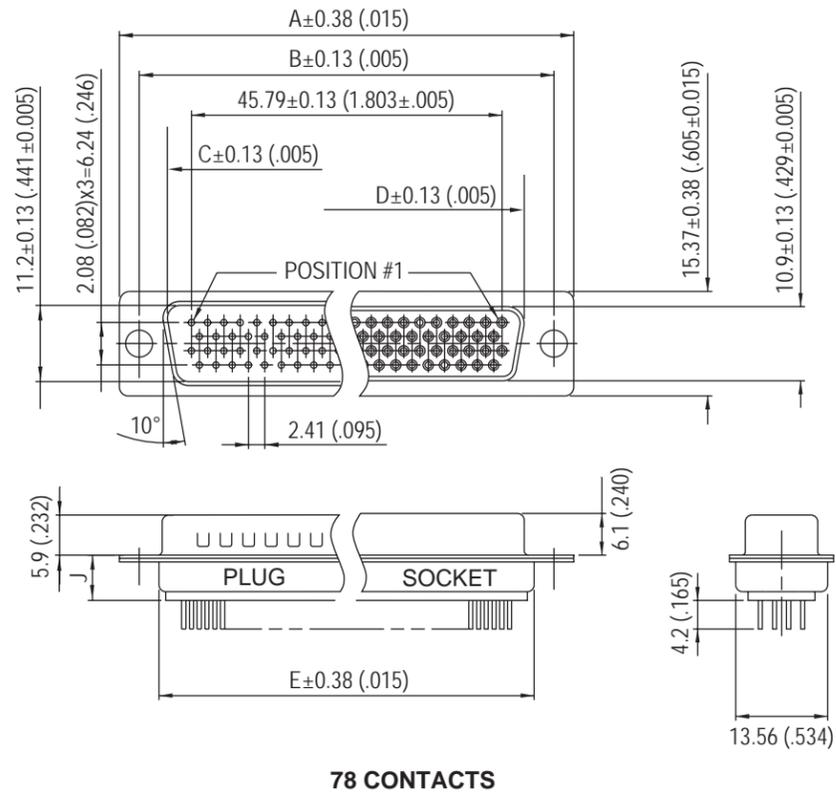

OVERALL DIMENSION

SD / E6



Panel mounting option

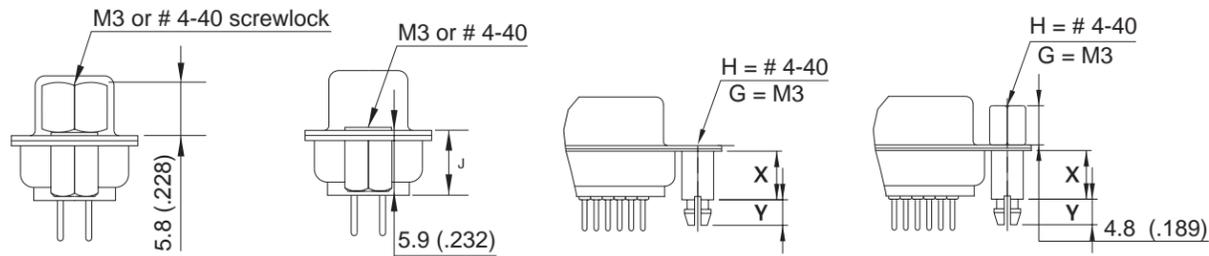

Front Female Screwlock    Threaded Rear Insert    RM5 Standoff Boardlock    RM8 Standoff Boardlock

	RM5 RM8	RM5G RM8G
X	6.0(.236)	12.7(.500)
Y	4.2(.165)	3.2(.126)
J	6.2(.244)	10.1(.397)

How to order

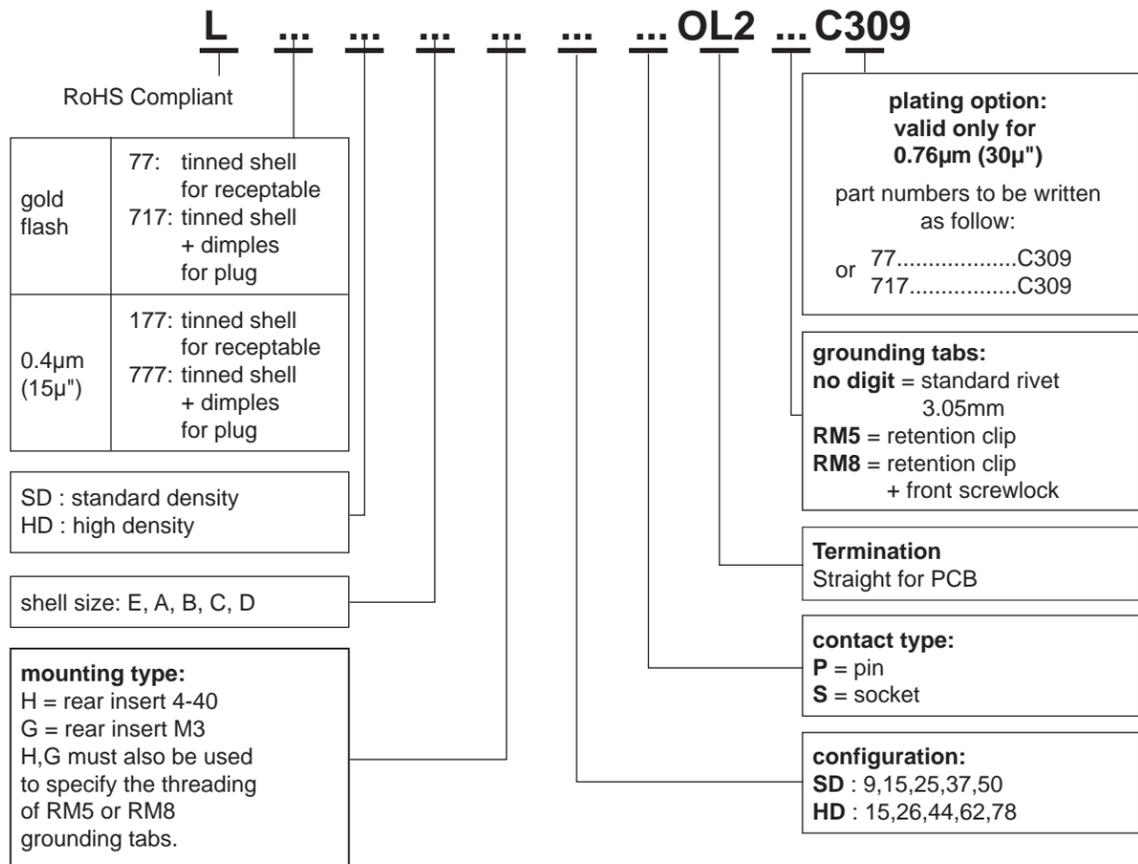

For special request, please consult factory

Do not hesitate to contact us for further information

# Amphenol

## Amphenol IT & Communication Products

Block A3/A4, The 4th Industrial District of Industrial Headquarters, Dong Keng Road Gong Ming Town, Shen Zhen China  
Fax:+86(0)755 2754 9955

**Technical Support**

Tel:+86(0)755 2717 7945  
Info-dsub@amphenol.com.cn  
http://www.dsubconnector.com

## RIGHT ANGLE BOARD MOUNT CONNECTORS



### Specifications

- Connectors according to: MIL C24308 - NFC 93425-HE5

Materials and Platings	
<b>Shells</b>	Steel, tin over nickel plating
<b>Insulator</b>	Glass-filled thermoplastic, UL 94V-0
<b>Pin contacts</b>	Brass, selected gold in mating area; 2.54µm (100 µ") min.tin on termination area over 1.27µm (50µ") min.nickel
<b>Socket contact</b>	Phosphor bronze, selected gold in mating area;2.54µ(100µ") min.tin on termination area over 1.27µm (50µ") min.nickel
<b>Rear insert</b>	Brass, 2.54µm (100µ") min.nickel plated
<b>Boardlock</b>	Phosphor bronze or Brass, 2.54µm (100µ") min.nickel plated
<b>Screwlock</b>	Brass, 2.54µm (100µ") min.nickel plated

Electrical Data	
<b>Current rating</b>	5A
<b>Voltage rating</b>	250V AC/ rms 50Hz
<b>Withstanding voltage</b>	1000V AC/rms 50Hz for one minute
<b>Insulation resistance</b>	1000MΩ at 500V DC
<b>Contact resistance</b>	15mΩ max

Climatic Data	
<b>Operating temperature</b>	-55°C to +125°C
<b>Salt spray</b>	24 hours

Mechanical Data				
<b>Single contact insertion force</b>	0.54kg (1.19lb) max			
<b>Single contact withdrawal force</b>	0.06kg (0.13lb) min			
<b>Mating and unmating force</b>				
Unit: kg ( lb)				
	A4 Style		1A Style	
<b>No. of Cts</b>	<b>Mate (max)</b>	<b>Unmate (min)</b>	<b>Mate (max)</b>	<b>Unmate (min)</b>
9	3.05 (6.74)	0.36 (0.79)	4.6 (10.17)	0.4 (0.88)
15	5.09 (11.24)	0.46 (1.01)	7.7 (17.02)	0.5 (1.10)
25	8.44 (18.66)	0.81 (1.8)	12.7 (28.07)	0.8 (1.77)
37	12.51 (27.65)	1.1 (2.47)	17.7 (39.12)	1.2 (2.65)
<b>Standard plating thickness</b>	<ul style="list-style-type: none"> <li>gold flash</li> <li>0.381µm (15µ") gold</li> <li>0.76 µm (30µ") gold</li> </ul>			

### DESCRIPTION

The Amphenol "SD" series features precision formed contacts and boardlocks.

This series gives you Amphenol's high standards of quality and reliability to meet all of your commercial requirements.

*Economical  
right angle PCB  
mount  
connectors*

### APPLICATIONS

- Industrial
- Telecom
- Any industry standard I/O connections

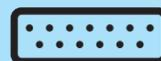

**Amphenol**

SD / E7

A4 style (MIL Footprint)

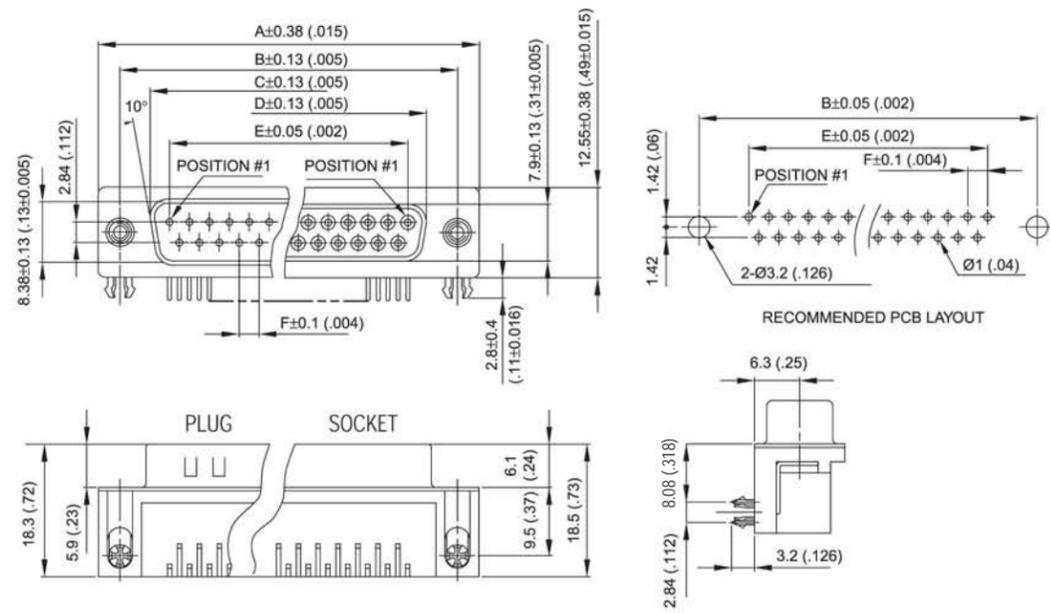

Nb OF CONTACTS	DIMENSIONS mm (inch)					
	A	B	C	D	E	F
9	30.84 (1.21)	24.99 (.98)	16.92 (.67)	16.24 (.64)	11.09 (.44)	2.74 (.108)
15	39.14 (1.54)	33.32 (1.31)	25.25 (.99)	24.56 (.97)	19.39 (.76)	2.74 (.108)
25	53.04 (2.09)	47.04 (1.85)	38.96 (1.53)	38.38 (1.51)	33.24 (1.31)	2.77 (.109)
37	69.32 (2.73)	63.50 (2.50)	55.42 (2.18)	54.76 (2.16)	49.86 (1.96)	2.77 (.109)

1A style (European Footprint)

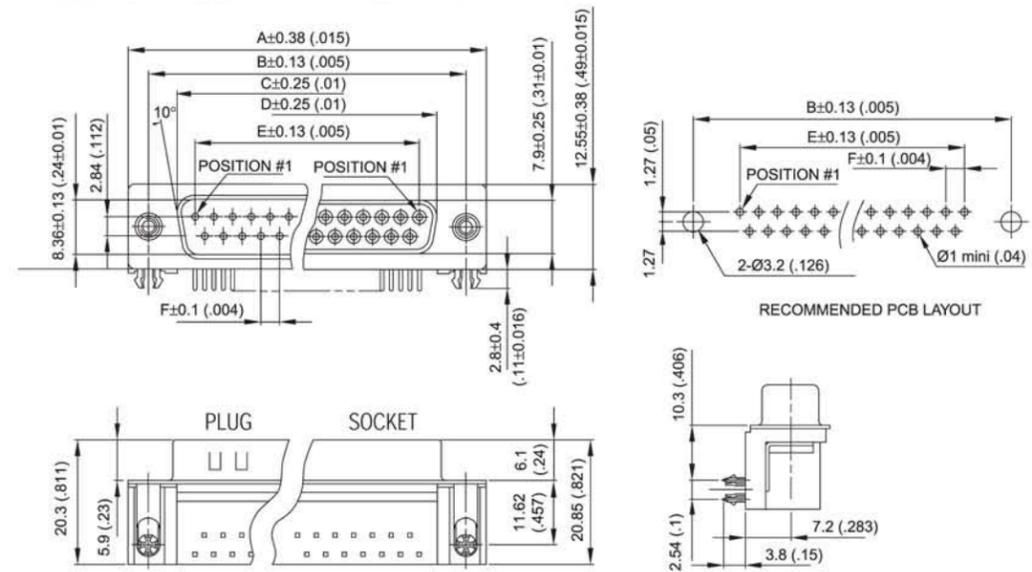

Nb OF CONTACTS	DIMENSIONS mm (inch)					
	A	B	C	D	E	F
9	30.84 (1.21)	24.99 (.98)	16.92 (.67)	16.24 (.64)	11.96 (.43)	2.74 (.108)
15	39.1 (1.54)	33.32 (1.31)	25.25 (.99)	24.66 (.97)	19.18 (.755)	2.74 (.108)
25	53.09 (2.09)	47.04 (1.85)	38.96 (1.53)	38.38 (1.51)	33.24 (1.31)	2.77 (.109)
37	69.4 (2.73)	63.50 (2.50)	55.42 (2.18)	54.84 (2.16)	49.86 (1.96)	2.77 (.109)

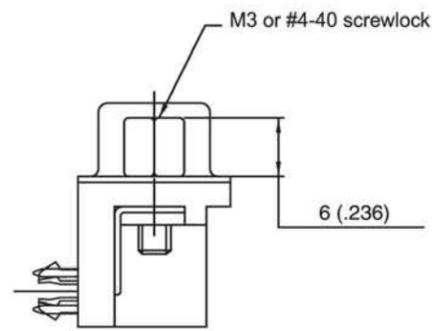

Front Female Screwlock  
**4F / 3F**

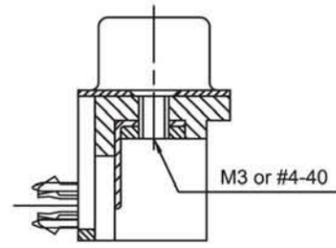

Threaded Rear Insert  
**4R / 3R**

How to order

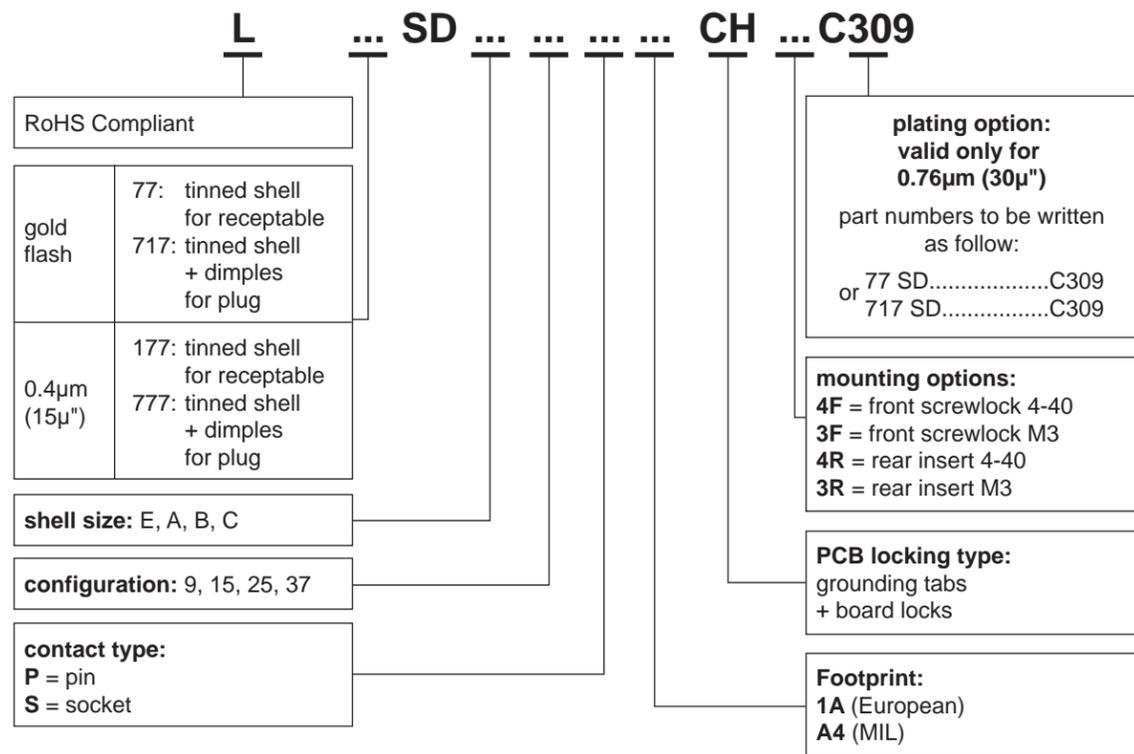

For special request, please consult factory





SD

D-Sub connectors - Stamped and Formed Contacts

## RIGHT ANGLE BOARD MOUNT CONNECTORS FOOTPRINT 14.99 mm (.590")

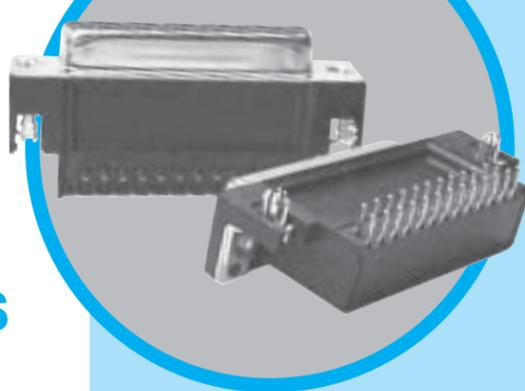

CHARACTERISTICS

### Specifications

- UL File: E119881
- Connectors according to MIL C24308

Materials and Platings	
<b>Shells</b>	Steel, tin over nickel plating
<b>Insulator</b>	Glass-filled thermoplastic, UL 94V-0
<b>Pin contacts</b>	Brass, selected gold in mating area; 2.54µm (100µ") min. tin on termination area over 1.27µm (50µ") min. nickel
<b>Socket contact</b>	Phosphor bronze, selected gold in mating area; 2.54µm (100µ") min. tin- on termination area over 1.27µm (50µ") min. nickel
<b>Rear insert</b>	Brass, 2.54µm (100µ") min. nickel plated
<b>Screwlock</b>	Brass, 2.54µm (100µ") min. nickel plated

Electrical Data	
<b>Current rating</b>	5A
<b>Voltage rating</b>	600V AC/rms 50Hz
<b>Withstanding voltage</b>	1000V AC/rms 50Hz for one minute
<b>Insulation resistance</b>	5000MΩ
<b>Contact resistance</b>	10mΩ max

Climatic Data	
<b>Operating temperature</b>	-55°C to +125°C
<b>Salt Spray</b>	24 hours

Mechanical Data		
<b>Mating and unmating force</b>		
Unit: kg ( lb)		
<b>No. of Cts</b>	<b>Mate (max)</b>	<b>Unmate (min)</b>
9 (size E)	3.05 (6.74)	0.36 (0.79)
15 (size A)	5.09 (11.24)	0.46 (1.01)
25 (size B)	8.44 (18.66)	0.81 (1.8)
37 (size C)	12.51 (27.65)	1.1 (2.47)
<b>Standard plating thickness</b>	<ul style="list-style-type: none"> <li>• gold flash</li> <li>• 0.4µm (15µ") gold</li> <li>• 0.76 µm (30µ") gold</li> </ul>	

DESCRIPTION

The Amphenol "SD" series features precision formed contacts and boardlocks.

This series gives you Amphenol's high standards of quality and reliability to meet all of your commercial requirements.

*Economical  
right angle PCB  
mount connectors*

APPLICATIONS

- Industrial
- Telecom
- Any industry standard I/O connections

SD / E8



Amphenol

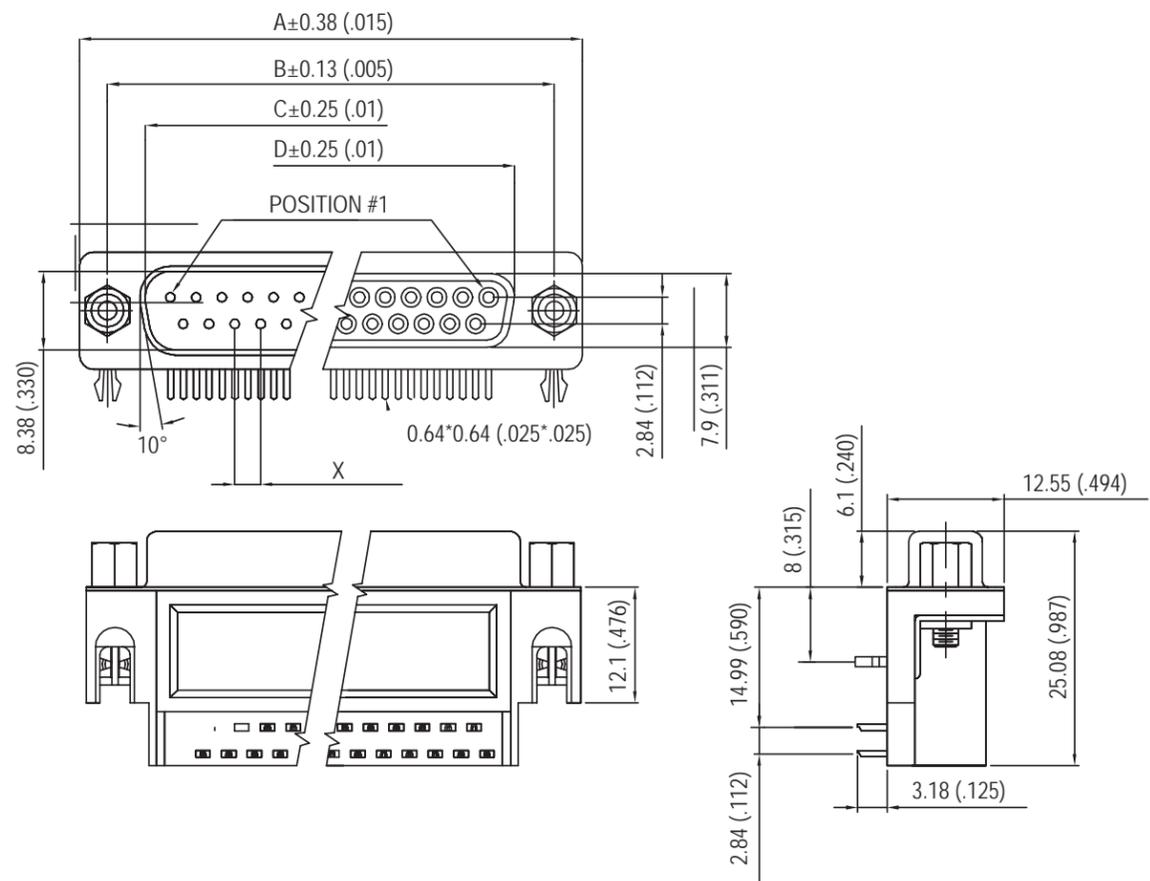

Recommended P.C.B. Layout

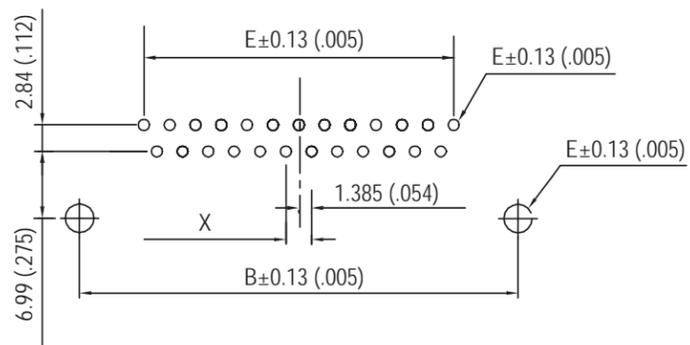

Nb OF CONTACTS	DIMENSIONS mm (inch)					
	A	B	C	D	E	X
9	30.84 (1.214)	24.99 (.984)	16.92 (.666)	16.26 (.640)	11.08 (.436)	2.74
15	39.24 (1.545)	33.32 (1.312)	25.25 (.994)	24.56 (.967)	19.39 (.763)	2.74
25	53.04 (2.088)	47.04 (1.852)	38.96 (1.534)	38.30 (1.508)	33.24 (1.309)	2.77
37	69.34 (2.730)	63.50 (2.500)	55.42 (2.182)	54.76 (2.156)	49.86 (1.963)	2.77

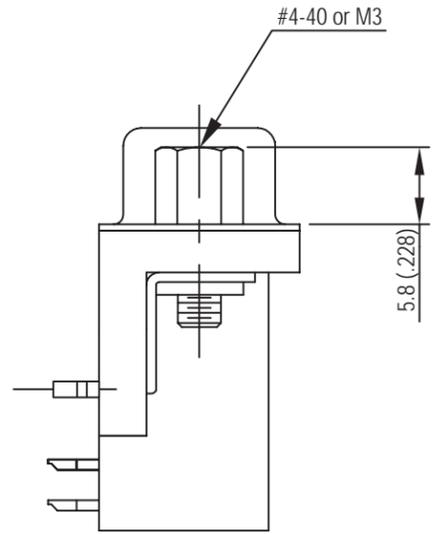

**Front Female Screwlock**  
4F/3F

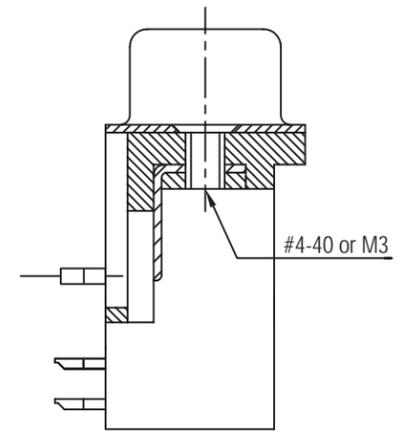

**Threaded Rear Insert**  
4R/3R

How to order

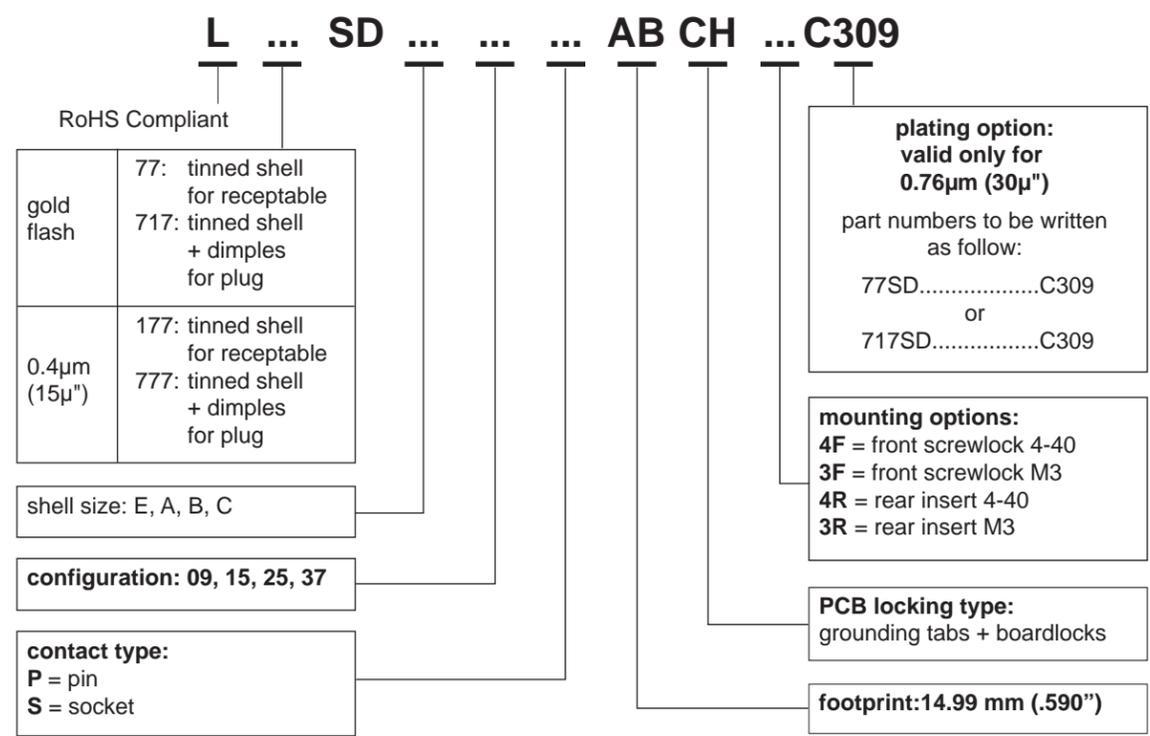

For special request, please consult factory

SD / E8

## STRAIGHT PCB TERMINATION ONE METAL SHELL CONNECTORS

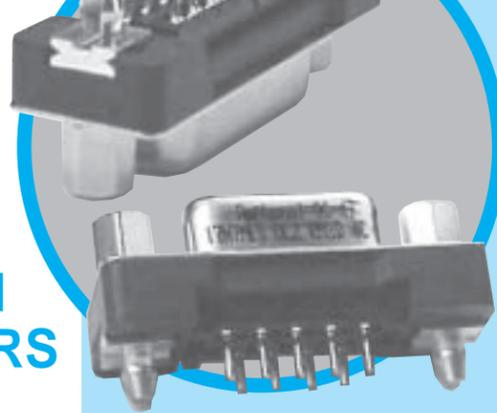

CHARACTERISTICS

### Specifications

- Connectors according to MIL C24308

Materials and Platings	
<b>Shells</b>	Steel, tin over nickel plating
<b>Insulator</b>	Glass-filled thermoplastic, UL 94V-0
<b>Contacts</b>	Copper alloy, with selective gold plating
<b>Boardlock</b>	Brass with nickel plating
<b>Screwlock</b>	Brass with nickel plating

Electrical Data	
<b>Current rating</b>	5A
<b>Voltage rating</b>	600V AC/rms 50Hz
<b>Withstanding voltage</b>	1000V AC/rms 50Hz for one minute
<b>Insulation resistance</b>	5000MΩ
<b>Contact resistance</b>	10mΩ max

Climatic Data	
<b>Operating temperature</b>	-55°C to +125°C

Mechanical Data		
<b>Mating and unmating force</b>		
Unit: kg ( lb)		
No. of Cts	Mate (max)	Unmate (min)
9	3.05 (6.74)	0.36 (0.79)
15	5.09 (11.24)	0.46 (1.01)
25	8.44 (18.66)	0.81 (1.8)
37	12.51 (27.65)	1.1 (2.47)
<b>Standard plating thicknesses</b>		
<ul style="list-style-type: none"> <li>• gold flash</li> <li>• 0.4µm (15µ") gold</li> <li>• 0.76 µm (30µ") gold</li> </ul>		

DESCRIPTION

The one shell D-sub Amphenol series features, stamped and formed contacts.

This series gives you Amphenol's high standards of quality and reliability to meet all of your commercial requirements

*Economical  
straight PCB,  
one shell  
connectors*

APPLICATIONS

- Industrial
- Telecom
- Any industry standard I / O connections

TS / E10

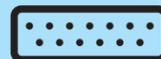

**Amphenol**

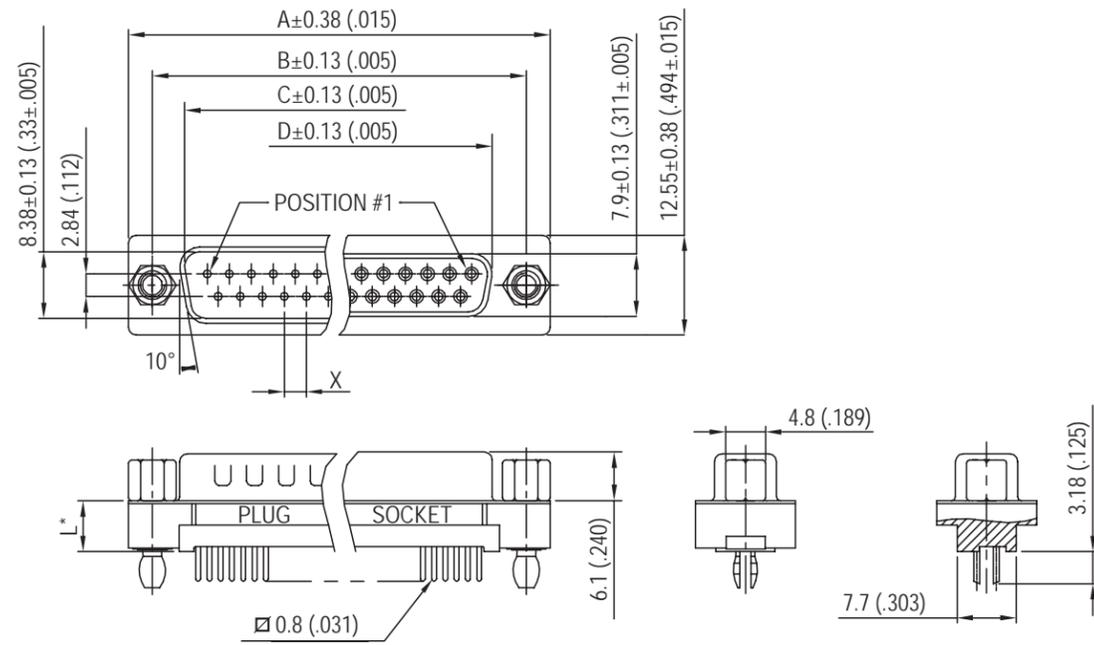

\*see chart "how to order"

RECOMMENDED P.C.B. LAYOUT

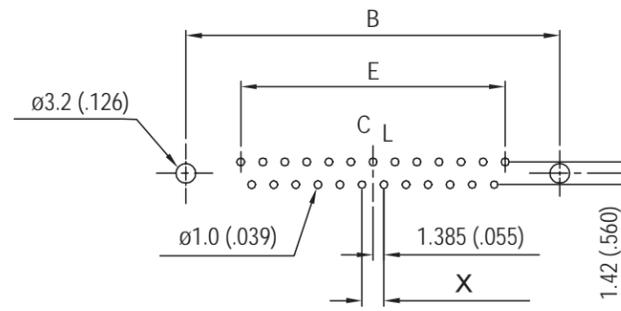

Nb OF CONTACTS	DIMENSIONS mm (inch)					
	A	B	C	D	E	X
9	30.84 (1.21)	24.99 (.984)	16.92 (.666)	16.26 (.640)	11.08 (.436)	2.74
15	39.24 (1.54)	33.32 (1.31)	25.25 (.994)	24.56 (.967)	19.39 (.763)	2.74
25	53.04 (2.09)	47.04 (1.85)	38.96 (1.53)	38.30 (1.51)	33.24 (1.31)	2.77
37	69.34 (2.73)	63.50 (2.50)	55.42 (2.18)	54.76 (2.16)	49.86 (1.96)	2.77

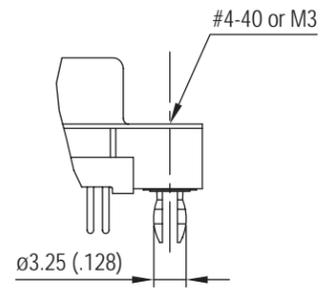

Boardlock with Threaded Insert  
**RM5**

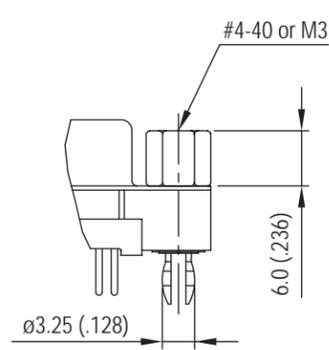

Boardlock with Front Screwlock  
**RM8**

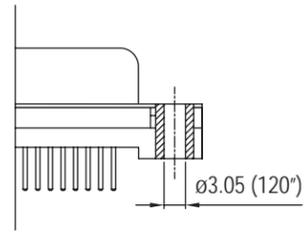

Clear Hole

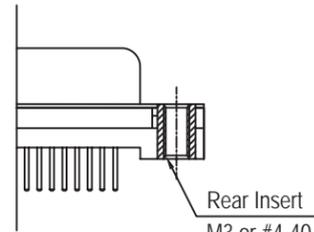

Rear Insert Threaded

How to order

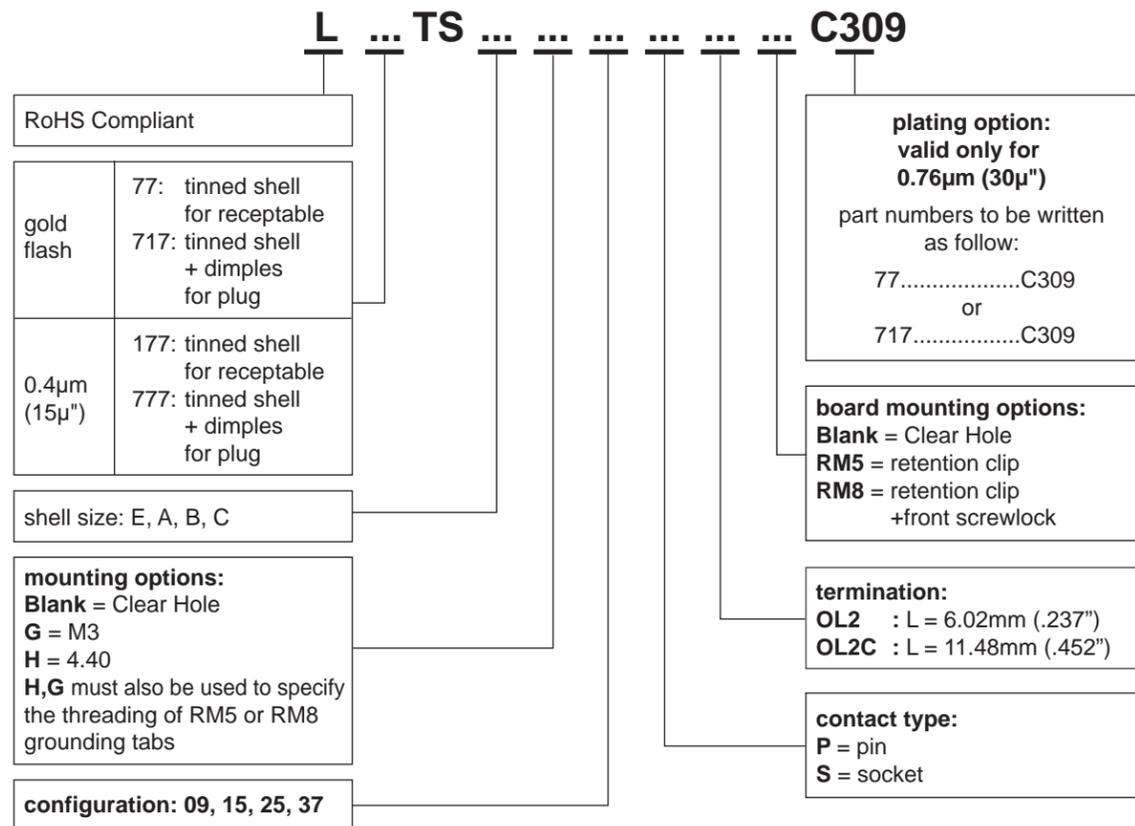

For special request, please consult factory

# RR-HR

D-Sub connectors - Stamped and Formed Contacts

## REAR RELEASE CRIMP CONNECTORS



CHARACTERISTICS

### Specifications

- Connectors according to MIL C24308

Materials and Platings	
<b>Shells</b>	Tinned steel with or without dimples on plug connector
<b>Insulator Boardlock</b>	Black glass-filled thermoplastic, UL 94V-0 Brass, 3µm to 5µm (118µ" to 197µ") tin over nickel 2µm to 3µm (78µ" to 118µ")
<b>Screwlock</b>	Brass, 6µm to 10µm (236µ" to 394µ") tin over nickel 2µm to 3µm (78µ" to 118µ")

Contacts	Under plating	Crimp side
0.2µm (8µ") gold	2µm (78µ") nickel	gold flash or tin
0.5µm (20µ") gold	2µm (78µ") nickel	gold flash or tin
0.76µm (30µ") gold	2µm (78µ") nickel	gold flash or tin

Electrical Data	
<b>Current rating</b>	5A
<b>Voltage rating</b>	500V AC/rms 50Hz
<b>Withstanding voltage</b>	<b>RR:</b> 1000V AC/rms 50Hz for 1 minute <b>HR:</b> 1000V AC/rms 60Hz for 1 minute
<b>Insulation resistance</b>	<b>RR:</b> 5000MΩ <b>HR:</b> 1000MΩ
<b>Contact resistance</b>	10mΩ max
<b>Wire size</b>	20-28 AWG max insulation Ø1.27mm (.05")

Climatic Data	
<b>Operating temperature</b>	-55°C to +125°C

Mechanical Data					
<b>Mating and unmating force</b> Unit: kg ( lb)					
No. of Cts		Mate (max)		Unmate (min)	
RR	HR	RR	HR	RR	HR
9 (size E)	15 (size E)	3.05 (6.74)	3.81 (8.42)	0.36 (0.79)	0.52 (1.14)
15 (size A)	26 (size A)	5.09 (11.24)	5.95 (13.16)	0.46 (1.01)	1.05 (2.32)
25 (size B)	44 (size B)	8.44 (18.66)	9.26 (20.46)	0.81 (1.8)	1.37 (3.02)
37 (size C)	62 (size C)	12.51 (27.65)	13.48 (29.78)	1.1 (2.47)	1.76 (3.88)
50 (size D)	78 (size D)	14.65 (32.38)	15.82 (34.96)	1.6 (3.56)	2.02 (4.46)

DESCRIPTION

Designed for high volume production, Amphenol's rear release crimp connector and contacts provide significant cost saving.

- EMI / RFI shell configuration.
- Removable, reusable contacts.
- Automatic and manual tooling available.

*Simplify  
your cable  
assemblies*

APPLICATIONS

- Commercial
- Industrial
- Telecom
- Any industry standard I / O connections

RR-HR / E11

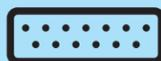

Amphenol

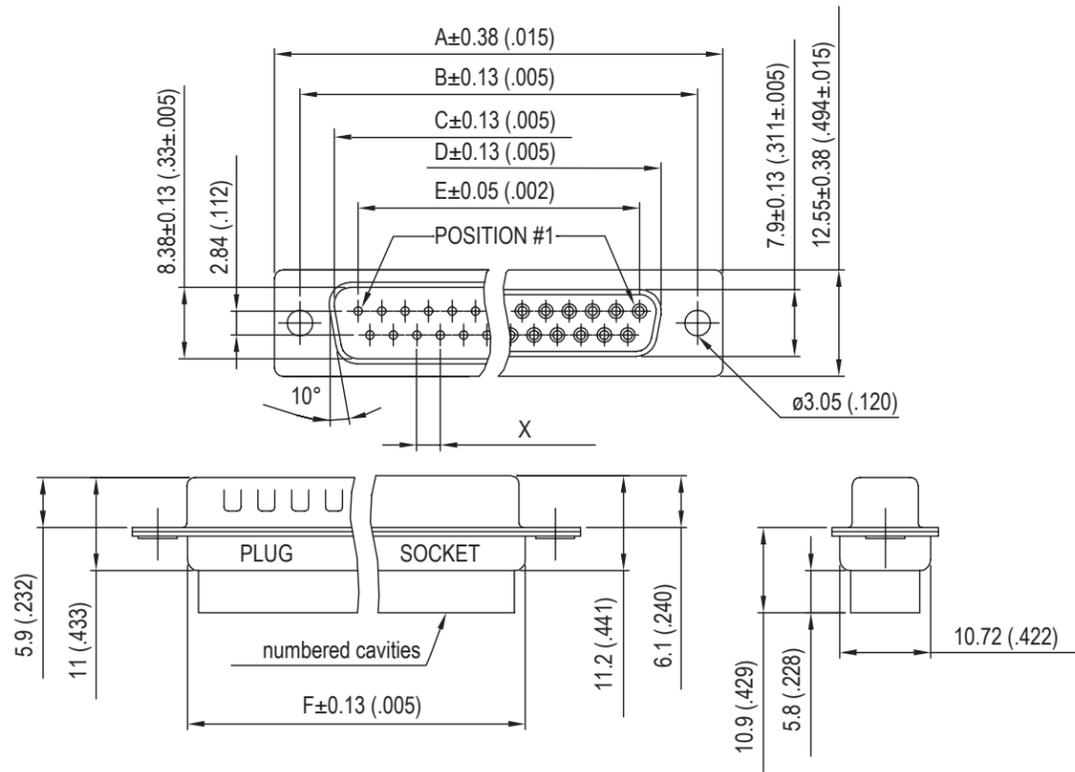

Nb OF CONTACTS	DIMENSIONS mm (inch)						
	A	B	C	D	E	F	X
9	30.84 (1.21)	24.99 (.98)	16.92 (.67)	16.24 (.64)	11.09 (.44)	19.28 (.76)	2.74
15	39.24 (1.54)	33.32 (1.31)	24.7 (.972)	24.56 (.97)	19.39 (.76)	27.51 (1.08)	2.74
25	53.04 (2.09)	47.04 (1.85)	38.96 (1.53)	38.38 (1.51)	33.24 (1.31)	41.30 (1.63)	2.77
37	69.32 (2.73)	63.50 (2.50)	55.42 (2.18)	54.76 (2.16)	49.86 (1.96)	57.71 (2.27)	2.77
50	67 (2.64)	61.11 (2.41)	52.86 (2.08)	52.34 (2.06)	44.32 (1.75)	55.3 (2.18)	2.77

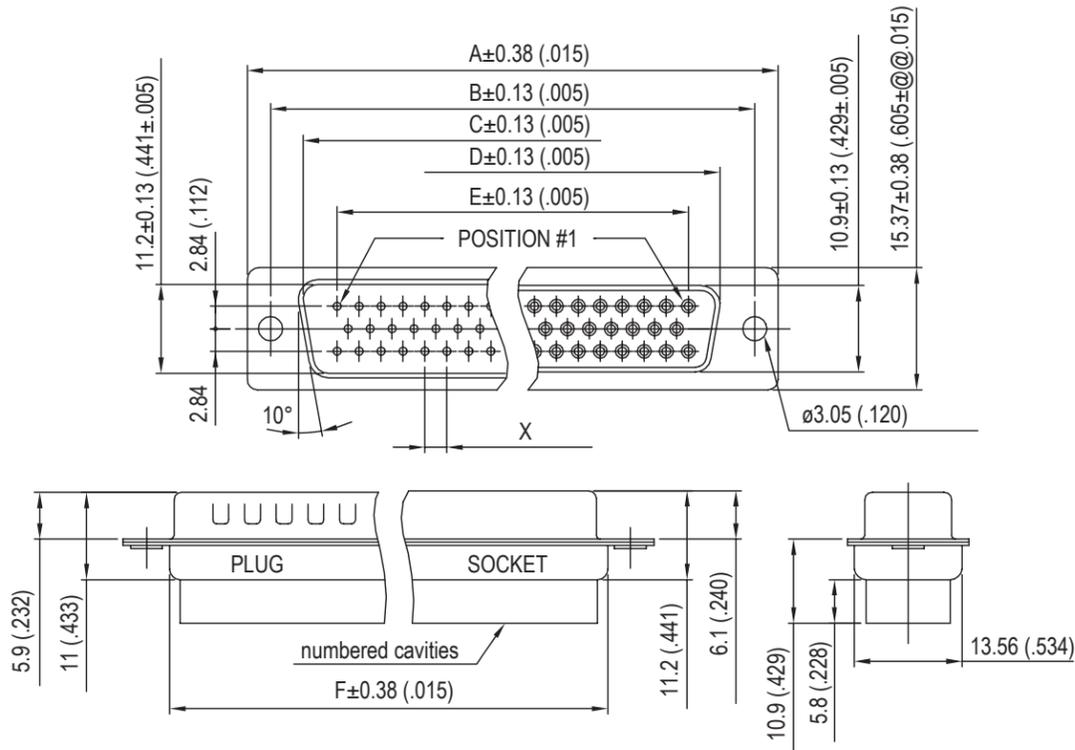



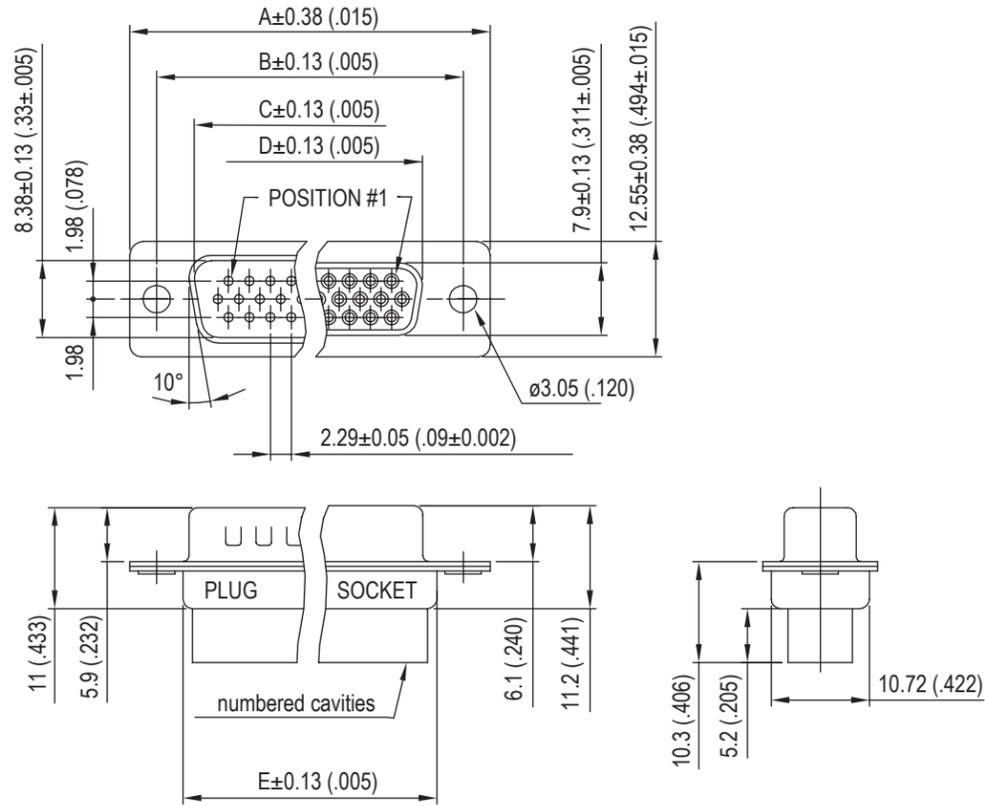

Nb OF CONTACTS	DIMENSIONS mm (inch)				
	A	B	C	D	E
15	30.84 (1.21)	24.99 (.98)	16.92 (.67)	16.24 (.64)	19.28 (.76)
26	39.24 (1.54)	33.32 (1.31)	24.7 (.972)	24.56 (.97)	27.51 (1.08)
44	53.04 (2.09)	47.04 (1.85)	38.96 (1.53)	38.38 (1.51)	41.30 (1.63)
62	69.32 (2.73)	63.50 (2.50)	55.42 (2.18)	54.76 (2.16)	57.71 (2.27)
78	67 (2.64)	61.11 (2.41)	52.86 (2.08)	52.34 (2.06)	55.3 (2.18)

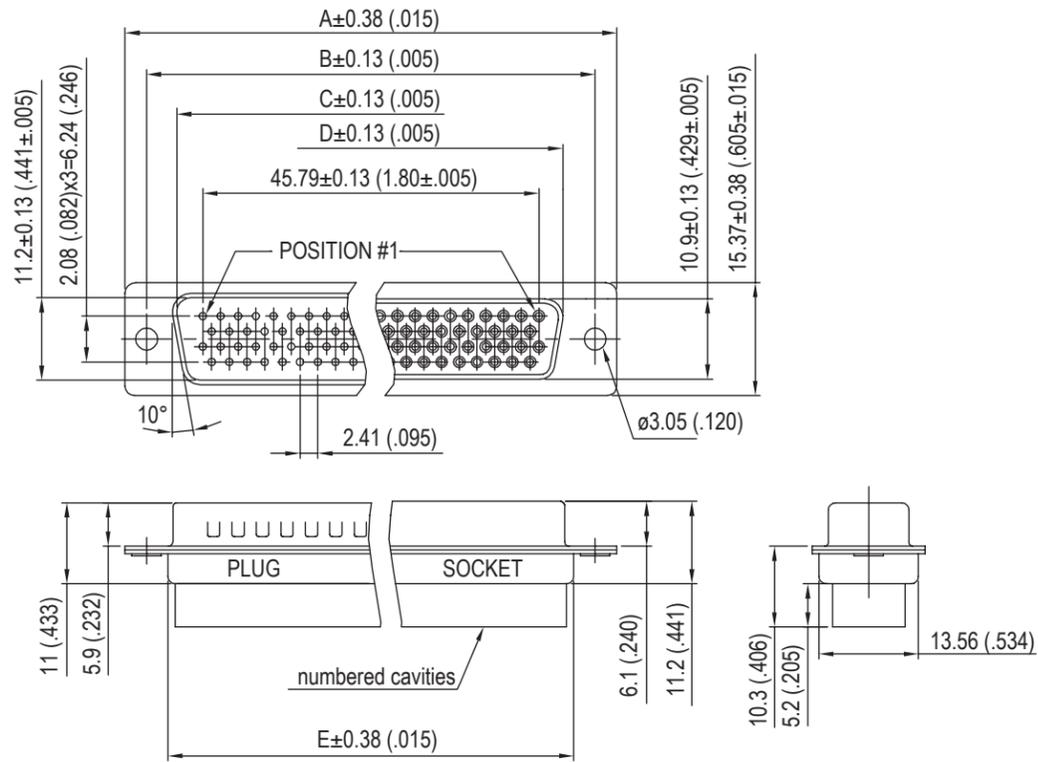

OVERALL DIMENSION

RR-HR / E11



Panel mounting option

Standard density:

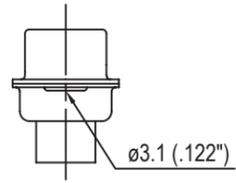

Standard rivet ø 3.1mm  
no digit

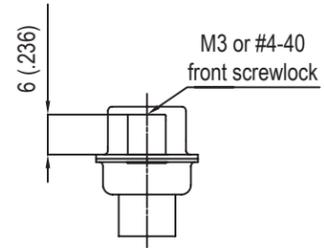

Fixed front female screwlock  
VF / VFM

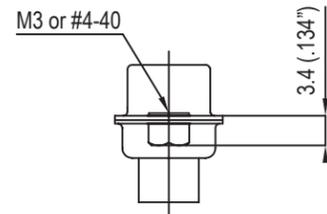

Threaded rear insert  
H / G

High density:

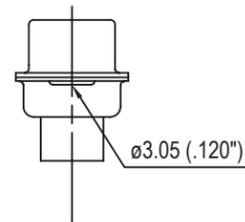

Standard rivet ø3.05mm  
no digit

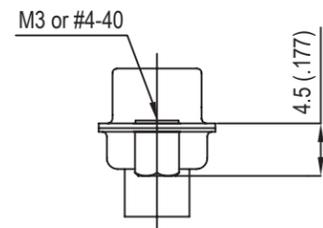

Threaded rear insert  
H / G

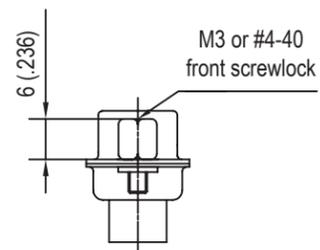

Fixed front female screwlock  
VF / VFM

Standard density:

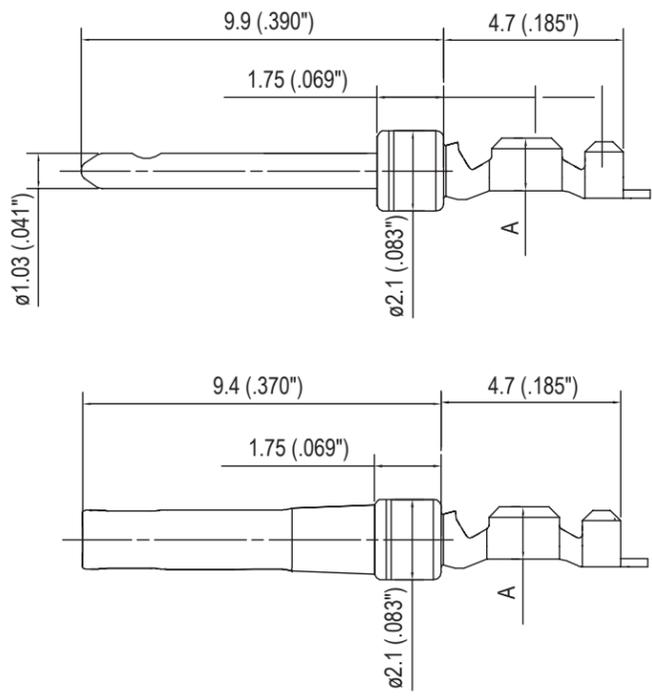
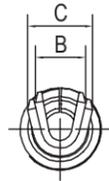

AWG	A	B	C
20-24	1.8 (.071")	1.9 (.075")	2.5 (.098")
24-28	1.4 (.055")	1.5 (.059")	1.7 (.066")

High density:

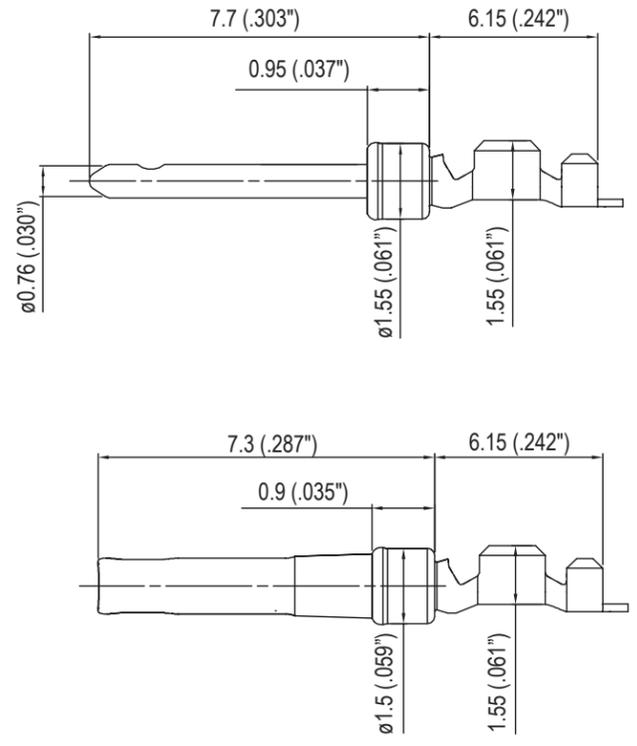
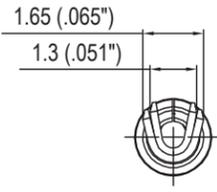

**Housings**

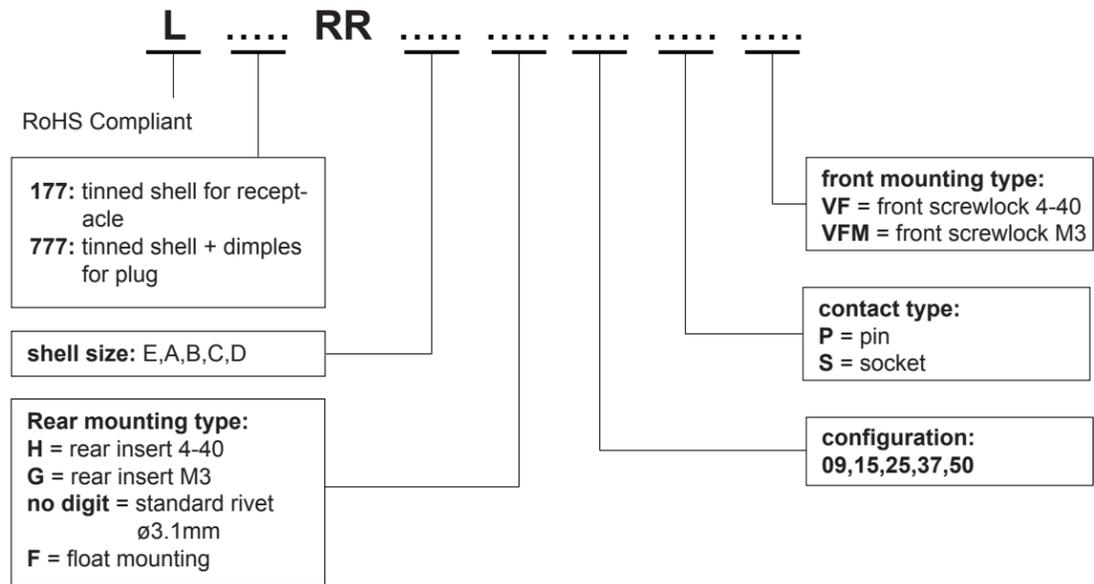

**Contacts**

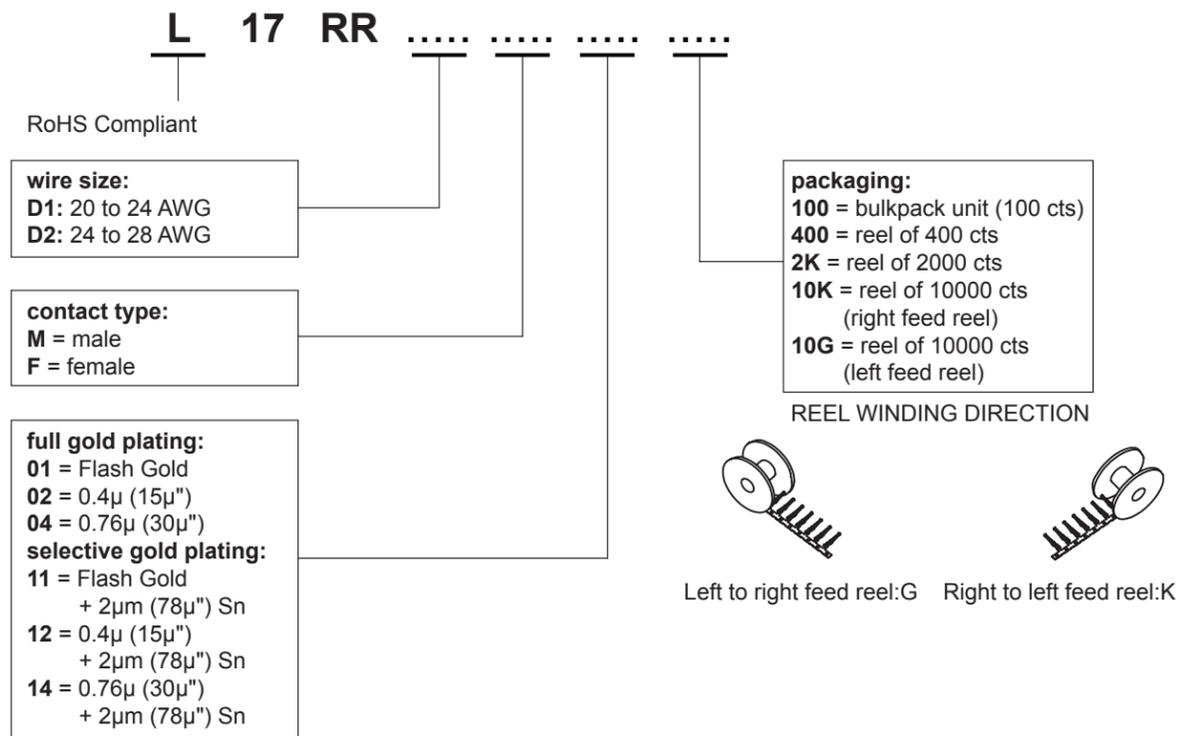

*For special request, please consult factory*

Housings

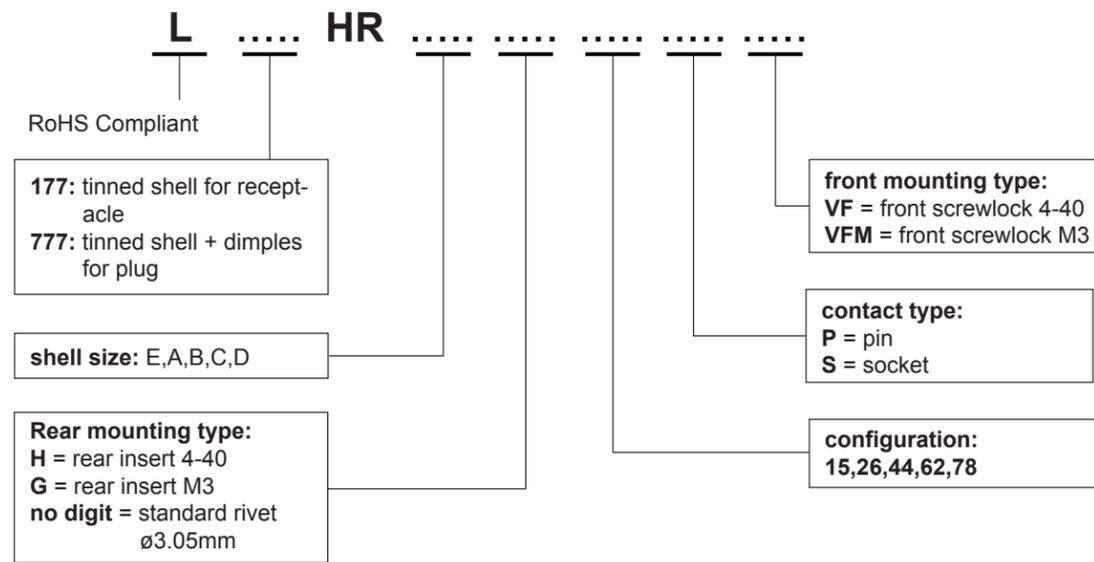

Contacts

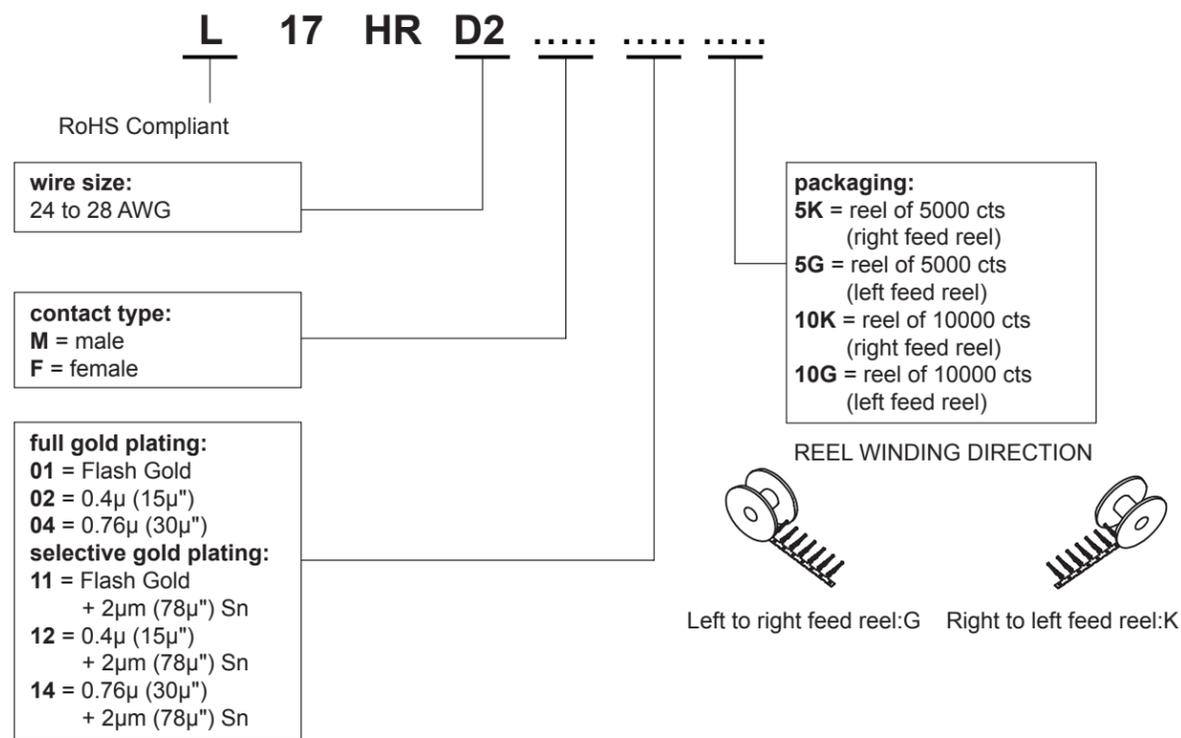

For special request, please consult factory

**For standard density crimp contacts: 17RR series**

- contact insertion and removal tool 17D 438 SP
- hand crimp tool for single contacts AWG 20 to 28 17D 440 SP
- hand crimp tool for reels of 400 contacts FA 0000 762
  - crimp dies: AWG 20 to 24 FA 0000 104
  - crimp dies: AWG 24 to 28 FA 0000 102
- stripping box FE 0400
- automatic crimp machine for reels of 2000 to 10000 contacts 970 MC
  - crimp dies: AWG 20 to 24 968 MC
  - crimp dies: AWG 24 to 28 972 MC

**For high density crimp contacts: 17HR series**

- automatic crimp machine for reels of 2000 to 10000 contacts 970 MC
  - crimp dies: AWG 24 to 28 973 MC

**Do not hesitate to contact us for further information**



## Amphenol

**Amphenol IT & Communication Products**

Block A3/A4, The 4th Industrial District of  
Industrial Headquarters, Dong Keng Road  
Gong Ming Town, Shen Zhen China  
Fax: +86(0)755 2754 9955

**Technical Support**

Tel: +86(0)755 2717 7945  
Info-dsub@amphenol.com.cn  
<http://www.dsubconnector.com>



## FLAT RIBBON D-SUB CONNECTORS

CHARACTERISTICS

### Specifications

- Connectors according to MIL C24308

Materials and Platings	
<b>Shells</b>	Steel with nickel plating
<b>Insulator</b>	Glass-filled thermoplastic, UL 94V-0
<b>Pin contacts</b>	Brass, selected gold in mating area; 2.54µm (100µ") min. tin on termination area over 1.27µm (50µ") min. nickel
<b>Socket contact</b>	Phosphor bronze, selected gold in mating area; 2.54µm (100µ") min. tin on termination area over 1.27µm (50µ") min. nickel
<b>Rear insert</b>	Brass, 2.54µm (100µ") min. nickel plated
<b>Screwlock</b>	Brass, 2.54µm (100µ") min. nickel plated

Electrical Data	
<b>Current rating</b>	5A
<b>Voltage rating</b>	250V AC/rms 60Hz
<b>Withstanding voltage</b>	1000V AC/rms 60Hz for one minute
<b>Insulation resistance</b>	1000MΩ
<b>Contact resistance</b>	20mΩ max

Climatic Data	
<b>Operating temperature</b>	-40°C to +125°C

Mechanical Data		
<b>Single contact insertion force</b>	0.54kg (1.19lb) max	
<b>Single contact withdrawal force</b>	0.06kg (0.13lb) min	
<b>Mating and unmating force</b>		
Unit: kg ( lb)		
No. of Cts	Mate (max)	Unmate (min)
9 (size E)	3.05 (6.74)	0.36 (0.79)
15 (size A)	5.09 (11.24)	0.46 (1.01)
25 (size B)	8.44 (18.66)	0.81 (1.8)
37 (size C)	12.51 (27.65)	1.1 (2.47)
<b>Standard plating thicknesses</b>		
• gold flash		
• 0.4µm (15µ") gold		
• 0.76 µm (30µ") gold		

DESCRIPTION

These connectors are suitable for compact requirement of modern peripheral equipment.

Special contact design allows usage of standard 1.27mm (.05") flat cable. Suitable with all standard D-Sub hoods.

*Simplify  
Your cable  
assemblies!*

APPLICATIONS

- Industrial
- Telecom
- Any industry standard I/O connections

DFR / E12



Amphenol

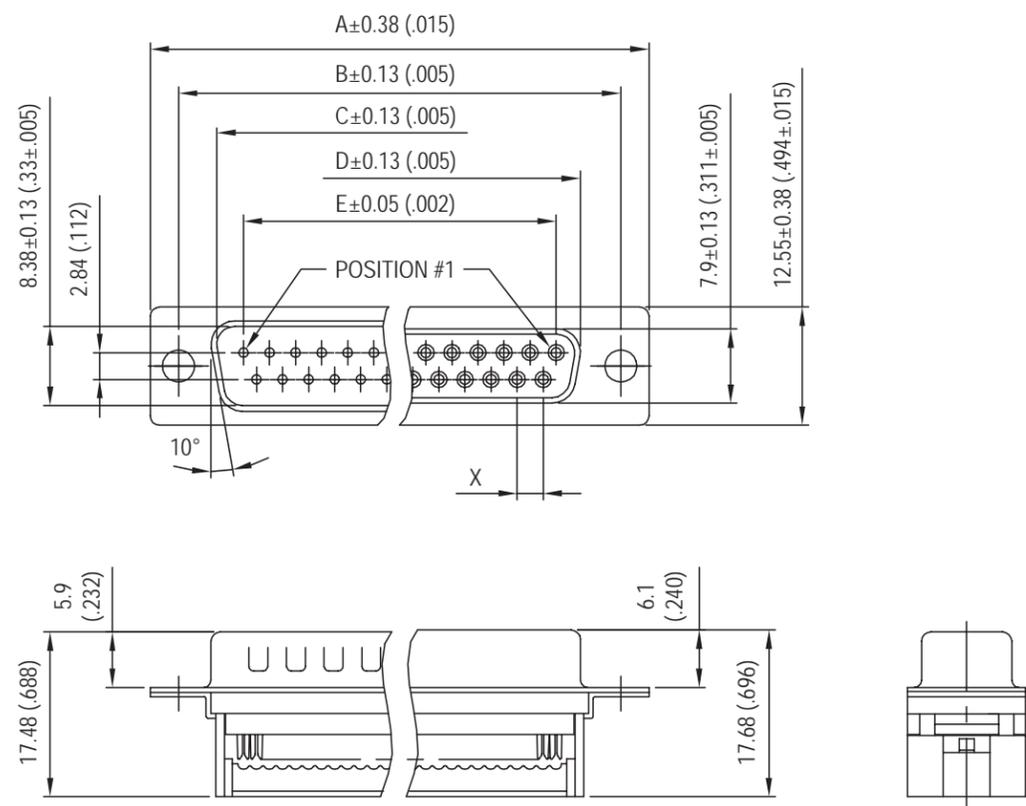

Nb OF CONTACTS	DIMENSIONS mm (inch)					
	A	B	C	D	E	X
9	30.84 (1.21)	24.99 (.984)	16.92 (.666)	16.24 (.639)	11.09 (.437)	2.74
15	39.24 (1.54)	33.32 (1.31)	24.70 (.972)	24.56 (.967)	19.39 (.763)	2.74
25	53.04 (2.09)	47.04 (1.85)	38.96 (1.53)	38.38 (1.51)	33.24 (1.31)	2.77
37	69.32 (2.73)	63.50 (2.50)	55.42 (2.18)	54.76 (2.16)	49.86 (1.96)	2.77

STRAIN RELIEF

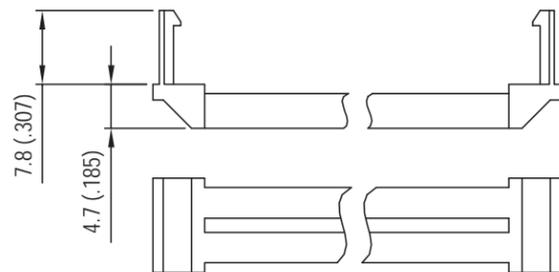



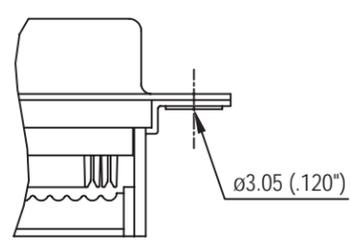

Standard rivet  $\varnothing 3.05\text{mm}$   
no digit

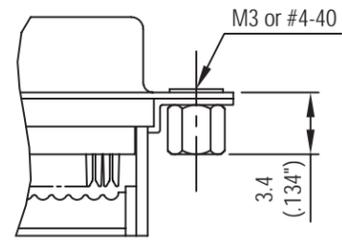

Threaded rear insert  
B / D

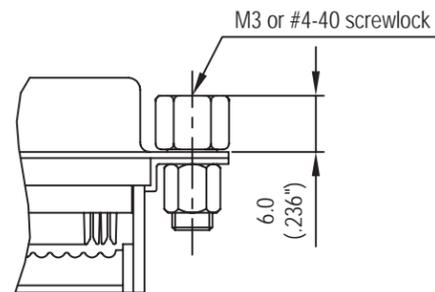

Front female screwlock  
A / C

Tool

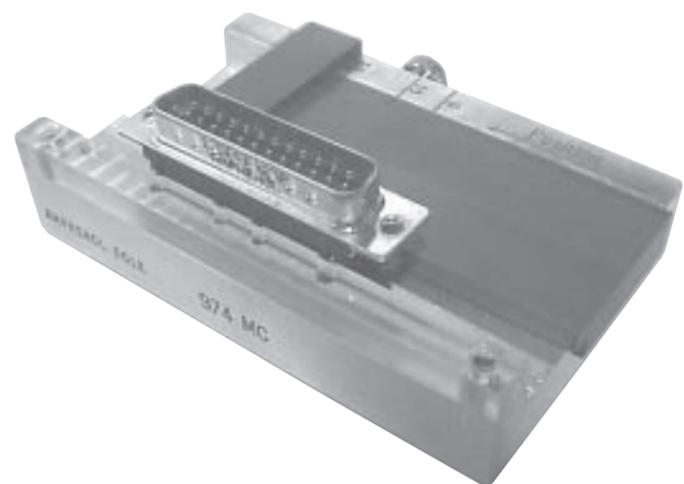

Support for hand termination tool:  
974MC



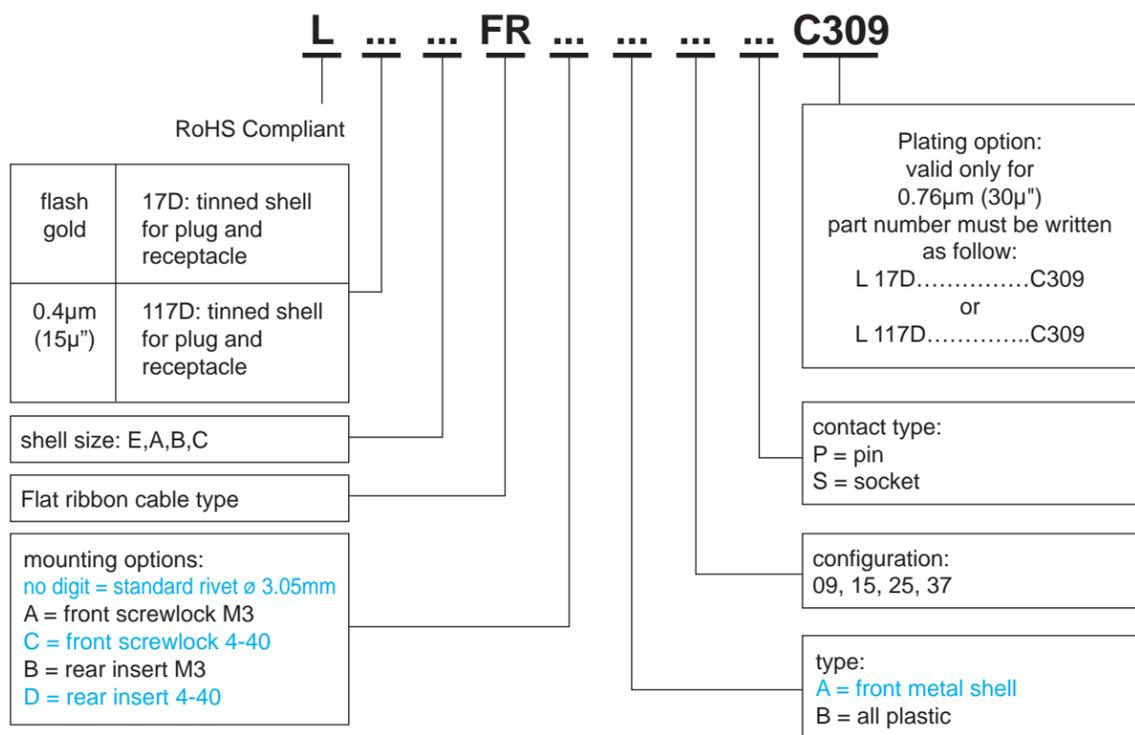

■ : Standard options

*For special request, please consult factory*

Do not hesitate to contact us for further information

## Amphenol

### Amphenol IT & Communication Products

Block A3/A4, The 4th Industrial District of  
 Industrial Headquarters, Dong Keng Road  
 Gong Ming Town, Shen Zhen China  
 Fax:+86(0)755 2754 9955

#### Technical Support

Tel:+86(0)755 2717 7945  
 Info-dsub@amphenol.com.cn  
<http://www.dsubconnector.com>

## DUAL PORT D-SUB CONNECTORS

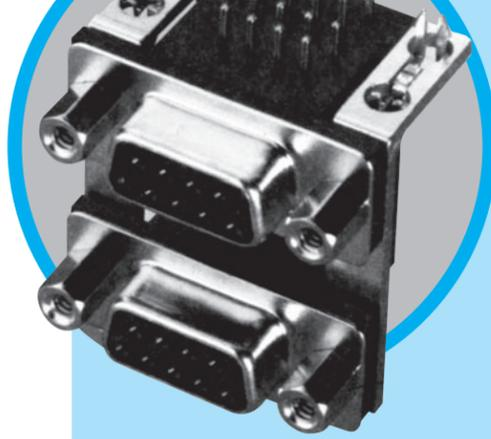

DESCRIPTION

Amphenol's G17H dual port connectors are a state of the art design. The front metal shell helps reduce EMI / RFI emissions.

Designed to save PC board space, Amphenol's dual port provides two I / O connectors in a minimal amount of board space.

*Economical dual port connectors*

APPLICATIONS

- Industrial
- Telecom
- Any industry standard I / O connections

17H / E13

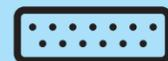

Amphenol

MAIN CHARACTERISTICS

### Specifications

- Connectors according to MIL C24308

Materials and platings	
Shells	Steel, tin plated
Insulator	Glass-filled thermoplastic, UL 94V-0
Pin contacts	Brass, selected gold in mating area; 2.54µm (100µ") min. tin on termination area over 1.27µm (50µ") min. nickel
Socket contact	Phosphor bronze, selected gold in mating area; 2.54µm (100µ") min. tin on termination area over 1.27µm (50µ") min. nickel
Rear insert	Brass, 2.54µm (100µ") min. nickel plated
Boardlock	Phosphor bronze, 2.54µm (100µ") min. tin plated
Screwlock	Brass, 2.54µm (100µ") min. nickel plated

Electrical Data	
Current rating	3A
Voltage rating	250V AC/rms 60Hz
Withstanding voltage	1000V AC/rms 60Hz for one minute
Insulation resistance	1000MΩ
Contact resistance	20mΩ max

Climatic Data	
Operating temperature	-55°C to +125°C
Salt spray	24 hours

Mechanical Data		
Single contact insertion force	0.54kg (1.19lb) max	
Single contact withdrawal force	0.06kg (0.13lb) min	
Mating and unmating force	Unit: kg ( lb)	
	Mate (max)	Unmate (min)
9	3.05 (6.74)	0.36 (0.79)
15	5.09 (11.24)	0.46 (1.01)
25	8.44 (18.66)	0.81 (1.8)
15 (Hi-den)	3.81 (8.42)	0.52 (1.14)
Standard plating thicknesses	<ul style="list-style-type: none"> <li>• gold flash</li> <li>• 0.4µm (15µ") gold</li> <li>• 0.76 µm (30µ") gold</li> </ul>	

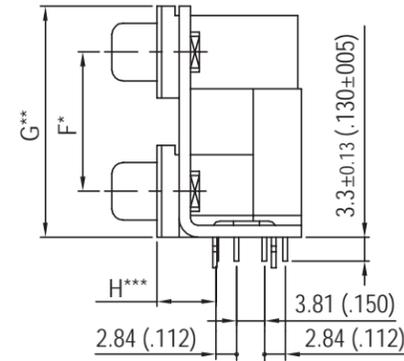
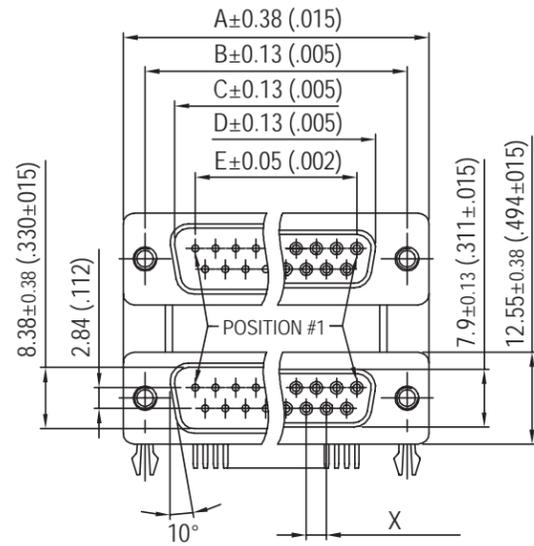
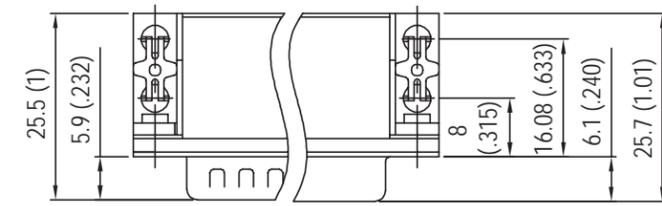

\* spacing between ports (see "how to order" for dimensions)  
 \*\* profile distance (see "how to order" for dimensions)  
 \*\*\* Footprint options (see "how to order" for dimensions)  
 H\*\*\* Standard Density (SD)  
 High Density (HD)  
 SD / SD = 8.08mm (.318")  
 SD / HD = 5.08mm (.200")  
           = 8.89mm (.350")  
 HD / HD = 8.89mm (.350")  
           = 5.08mm (.200")

**Recommended P.C.B. Layout**

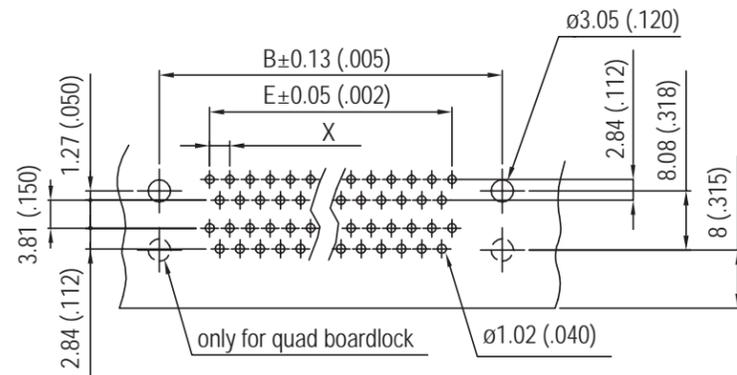

Shell Size	Nb OF CONTACTS	DIMENSIONS mm (inch)				
		A	B	C PLUG	D SOCKET	E
E	9/HD 15	30.84 (1.21)	24.99 (.984)	16.92 (.666)	16.24 (.639)	11.09 (.437)
A	15/HD 26	39.24 (1.54)	33.32 (1.31)	24.7 (.972)	24.56 (.967)	19.39 (.763)
B	25	53.04 (2.09)	47.04 (1.85)	38.96 (1.53)	38.38 (1.51)	33.24 (1.31)
E	15 (Hi-den)	30.84 (1.21)	24.99 (.984)	16.92 (.666)	16.24 (.639)	10.31 (.406)
C	37	69.32 (2.73)	63.50 (2.50)	55.42 (2.18)	54.76 (2.16)	49.86 (1.96)

Flange mounting options:

Flange mounting options:

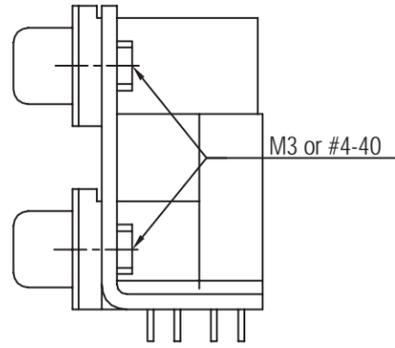

Threaded rear insert  
0 / 4

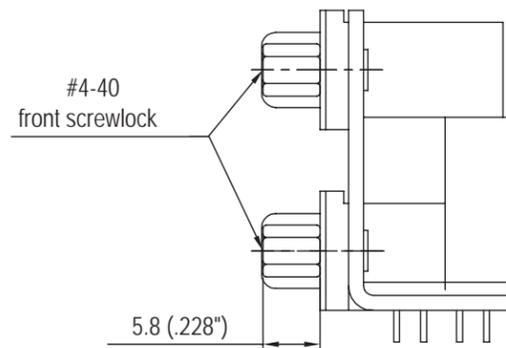

Fixed front female screwlock  
7

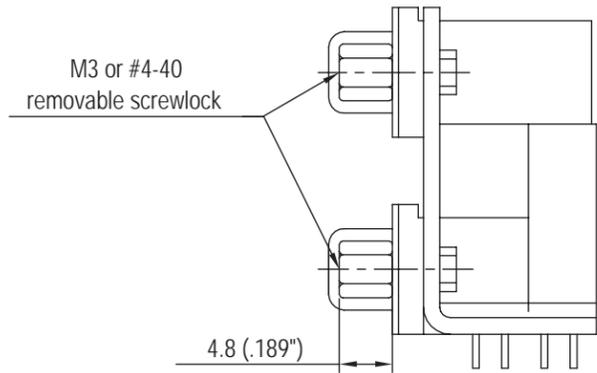

Removable female screwlock  
1 / 5

Board mounting options:

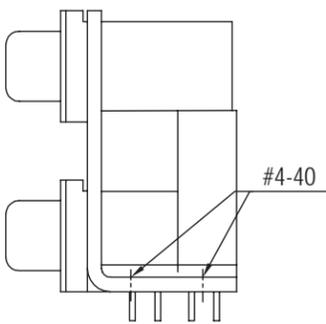

Threaded hole  
1

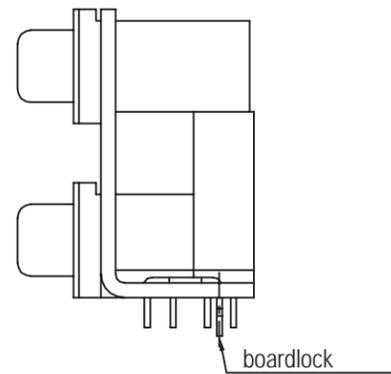

Dual arrowhead boardlock  
2

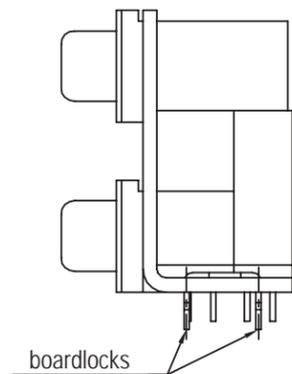

Quad arrowhead boardlock  
3



L17H X X X X X X X X

**Spacing Between Ports**

- 1 - F = 15.88mm (.625")  
G = 28.42mm (1.12")
- 2 - F = 19.05mm (.750")  
G = 31.60mm (1.24")
- 3 - F = 22.86mm (.900")  
G = 35.41mm (1.39")
- 4 - **SCSI**  
G = 12.80mm (.504")
- 7 - F = 20.70mm (.815")  
G = 32.20mm (1.26")

**Top Connector**

- 1 = 9 Pos. Male
- 2 = 9 Pos. Female
- 3 = 15 Pos. Male
- 4 = 15 Pos. Female
- 5 = 25 Pos. Male
- 6 = 25 Pos. Female
- 7 = 15 Pos. High Density Female
- 8 = 50 Pos. Female SCSI
- 9 = 26 Pos. High Density Female
- J = 15 Pos. High Density Male
- D = 37 Pos. Male
- E = 37 Pos. Female
- F = 44 Pos. High Density Male
- G = 44 Pos. High Density Female
- M = 62 Pos. High Density Male
- N = 62 Pos. High Density Female
- P = 78 Pos. High Density Male
- Q = 78 Pos. High Density Female

**Bottom Connector**

- 1 = 9 Pos. Male
- 2 = 9 Pos. Female
- 3 = 15 Pos. Male
- 4 = 15 Pos. Female
- 5 = 25 Pos. Male
- 6 = 25 Pos. Female
- 7 = 15 Pos. High Density Female
- 8 = 50 Pos. Female SCSI
- 9 = 26 Pos. High Density Female
- K = 15 Pos. High Density Male
- D = 37 Pos. Male
- E = 37 Pos. Female
- F = 44 Pos. High Density Male
- G = 44 Pos. High Density Female
- M = 62 Pos. High Density Male
- N = 62 Pos. High Density Female
- P = 78 Pos. High Density Male
- Q = 78 Pos. High Density Female
- R = 9 Pos. Male + 9 Pos. Male
- S = 9 Pos. Female + 9 Pos. Female

**Footprint Options**

- SD / SD  
BLANK = 8.08mm (.318")
- SD / HD  
BLANK = 5.08mm (.200")  
889 = 8.89mm (.350")
- HD / HD  
BLANK = 8.89mm (.350")  
508 = 5.08mm (.200")

**Flange Mounting Options**

- 0 = 4-40unc Rear Insert
- 1 = 4-40unc Removable Screwlock
- 3 = 3.05mm (.120") Clear Hole
- 4 = M3 Rear Insert
- 5 = M3 Removable Screwlock
- 7 = 4-40unc Fixed Front Screwlock

**Board Mounting Options**

- 1 = 4 \* Threaded 4-40unc Inserts
- 2 = Dual Arrowhead Boardlocks
- 3 = Quad Arrowhead Boardlocks
- 4 = 3.18mm (.125") Clear Hole

**Shell Plating**

- 1 = Bright Tin / Nickel
- 2 = Nickel

**Contact Plating**

- 0 = Flash Gold
- 1 = 0.4µm (15µ") Gold
- 2 = 0.76µm (30µ") Gold
- 3 = Full Flash Gold
- 4 = 1.27µm (50µ") Gold

*For special request, please consult factory*

Do not hesitate to contact us for further information

## Amphenol

**Amphenol IT & Communication Products**

Block A3/A4, The 4th Industrial District of  
Industrial Headquarters, Dong Keng Road  
Gong Ming Town, Shen Zhen China  
Fax:+86(0)755 2754 9955

**Technical Support**

Tel:+86(0)755 2717 7945  
Info-dsub@amphenol.com.cn  
<http://www.dsubconnector.com>

# HT

D-Sub connectors - Stamped and Formed Contacts

## RIGHT ANGLE HIGH TEMPERATURE AND HIGH DENSITY CONNECTORS



CHARACTERISTICS

### Specifications

- Connectors according to MIL C24308

Materials and Platings	
Shell	Steel, tin over nickel plating
Insulator	Glass filled thermoplastic, UL 94V-0
Contacts	Copper alloy, selective gold plating
Rear insert	Brass with nickel plating
Screwlock	Brass with nickel plating
Grounding clip	Copper alloy with tin plating

Electrical Data	
Current rating	3A
Voltage rating	300V AC/rms 50Hz
Withstanding voltage	1000V AC/rms 50Hz for one minute
Insulation resistance	5000MΩ
Contact resistance	10mΩ max

Climatic Data	
Operating temperature	-55°C to +150°C, resist to short term (30s) at 260°C

Mechanical Data		
<b>Mating and unmating force</b>		
Unit: kg ( lb)		
No. of Cts	Mate (max)	Unmate (min)
15	3.81 (8.42)	0.52 (1.14)
26	5.95 (13.16)	1.05 (2.32)
44	9.26 (20.46)	1.37 (3.02)
62	13.48 (29.78)	1.76 (3.88)
<b>Standard plating thicknesses</b>		
<ul style="list-style-type: none"> <li>• gold flash</li> <li>• 0.4 μm (15μ") gold</li> <li>• 0.76 μm (30μ") gold</li> </ul>		

DESCRIPTION

The Amphenol "HT" series allows the customers to use through hole connectors with reflow soldering process.

This series gives you Amphenol's high standards of quality and reliability to meet of your commercial requirements

*Economical  
right angle PCB,  
high temperature  
connectors*

APPLICATIONS

- Industrial
- Telecom
- Any industry standard I / O connections

HT / E14

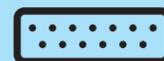

Amphenol

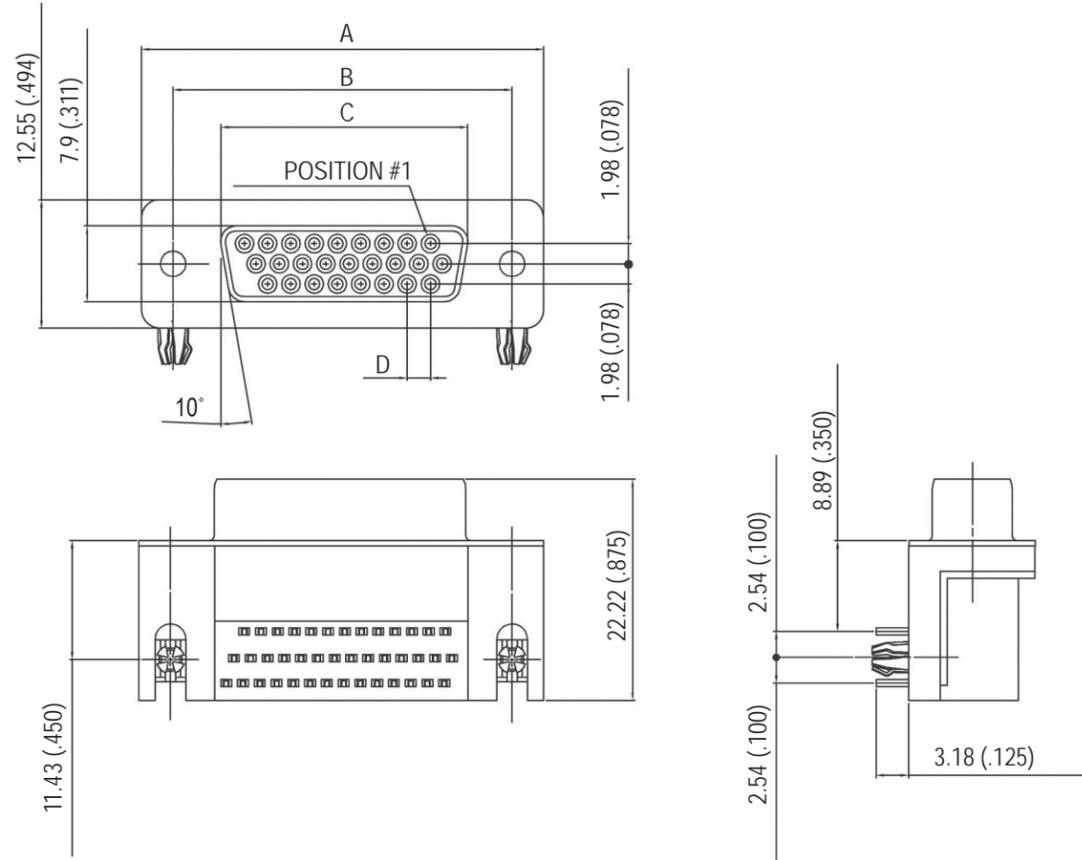

Nb OF CONTACTS	Dimensions mm (inch)			
	A	B	C	D
15	30.84 (1.214)	24.99 (.984)	16.26 (.640)	2.29 (.090)
26	39.24 (1.545)	33.32 (1.312)	24.56 (.967)	2.29 (.090)
44	53.04 (2.088)	47.04 (1.852)	38.30 (1.508)	2.29 (.090)
62	69.34 (2.730)	63.50 (2.500)	54.76 (2.156)	2.41 (.095)



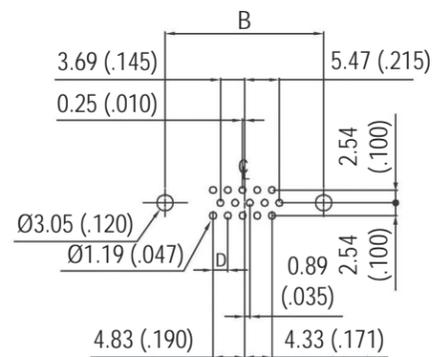

15 PIN

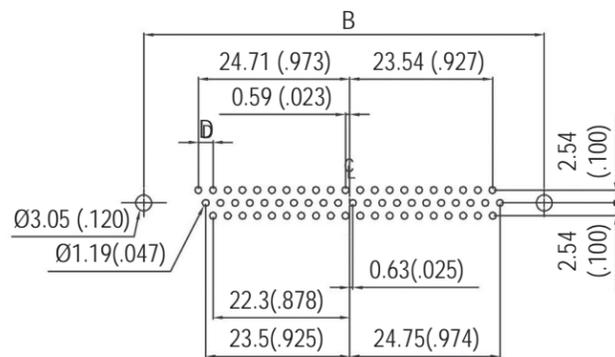

62 PIN

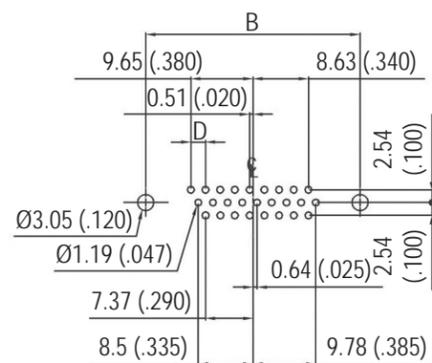

26 PIN

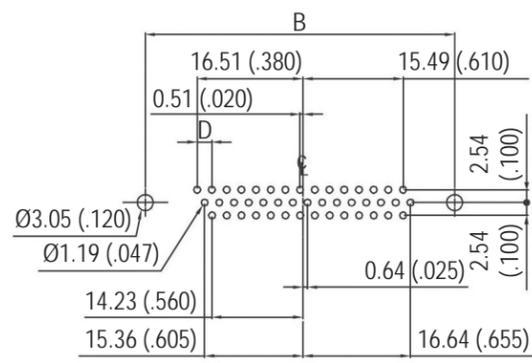

44 PIN

Panel mounting option

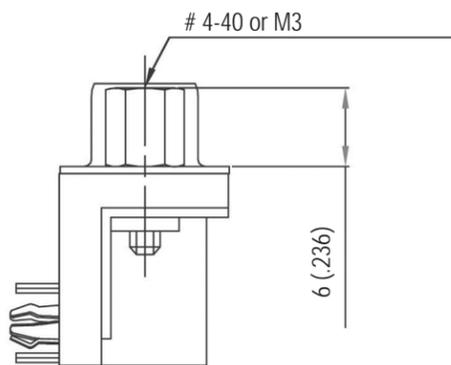

Front female screwlock  
4F/3F

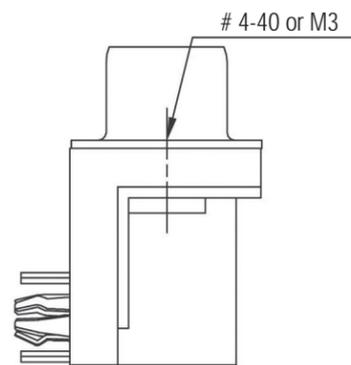

Threaded rear insert  
4F/3F

HT / E14



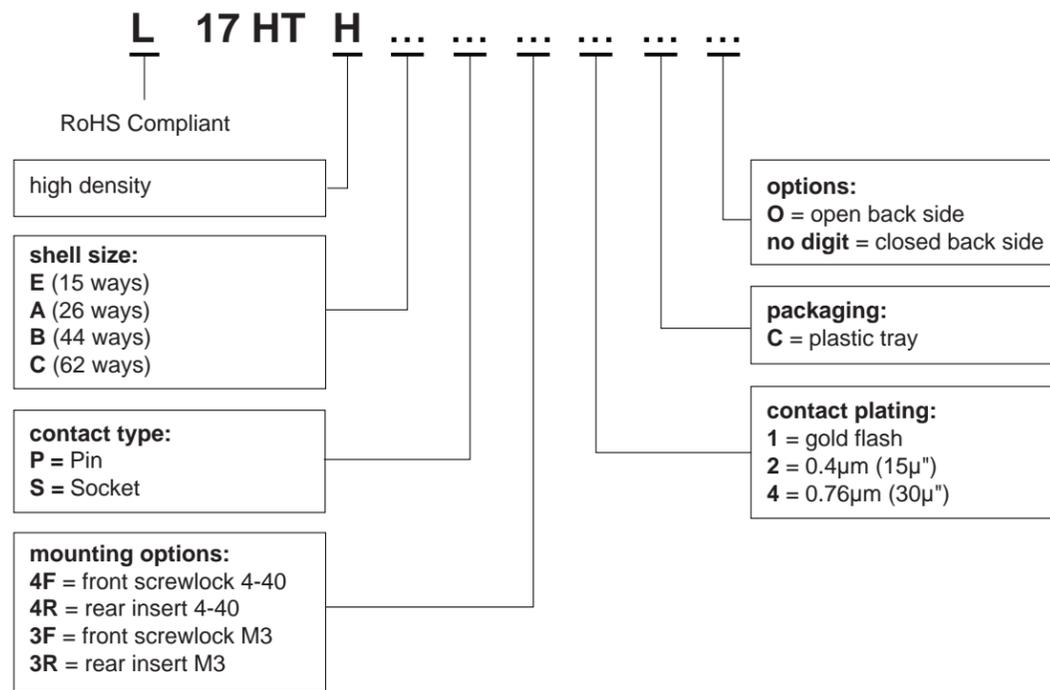

*For special request, please consult factory*

Do not hesitate to contact us for further information

## Amphenol

### Amphenol IT & Communication Products

Block A3/A4, The 4th Industrial District of  
 Industrial Headquarters, Dong Keng Road  
 Gong Ming Town, Shen Zhen China  
 Fax:+86(0)755 2754 9955

#### Technical Support

Tel:+86(0)755 2717 7945  
 Info-dsub@amphenol.com.cn  
<http://www.dsubconnector.com>

# HT

D-Sub connectors - Stamped and Formed Contacts

## STRAIGHT PCB TERMINATION HIGH TEMPERATURE CONNECTORS

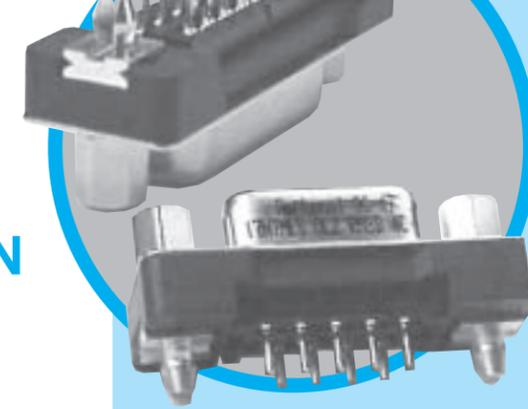

CHARACTERISTICS

### Specifications

- Connectors according to MIL C24308

Materials and Platings	
<b>Shell</b>	Steel, tin over nickel plating
<b>Insulator</b>	Glass-filled thermoplastic, UL 94V-0
<b>Contacts</b>	Copper alloy, selective gold plating
<b>Boardlock</b>	Brass with nickel plating
<b>Screwlock</b>	Brass with nickel plating

Electrical Data	
<b>Current rating</b>	5A
<b>Voltage rating</b>	600V AC/rms 50Hz
<b>Withstanding voltage</b>	1000V AC/rms 50Hz for one minute
<b>Insulation resistance</b>	5000MΩ
<b>Contact resistance</b>	10mΩ max

Climatic Data	
<b>Operating temperature</b>	-55°C to +150°C, resist to short term (30s) at 260°C

Mechanical Data		
<b>Mating and unmating force</b>		
Unit: kg ( lb)		
No. of Cts	Mate (max)	Unmate (min)
9	3.05 (6.74)	0.36 (0.79)
15	5.09 (11.24)	0.46 (1.01)
25	8.44 (18.66)	0.81 (1.8)
37	12.51 (27.65)	1.1 (2.47)
<b>Standard plating thicknesses</b>		
• gold flash		
• 0.76 μm (30μ") gold		

DESCRIPTION

The Amphenol "HT" series allows the customers to use through hole connectors with reflow soldering process.

This series gives you Amphenol's high standards of quality and reliability to meet all of your commercial requirements

*Economical  
straight PCB,  
high temperature  
connectors*

APPLICATIONS

- Industrial
- Telecom
- Any industry standard I / O connections

HT / E15



Amphenol

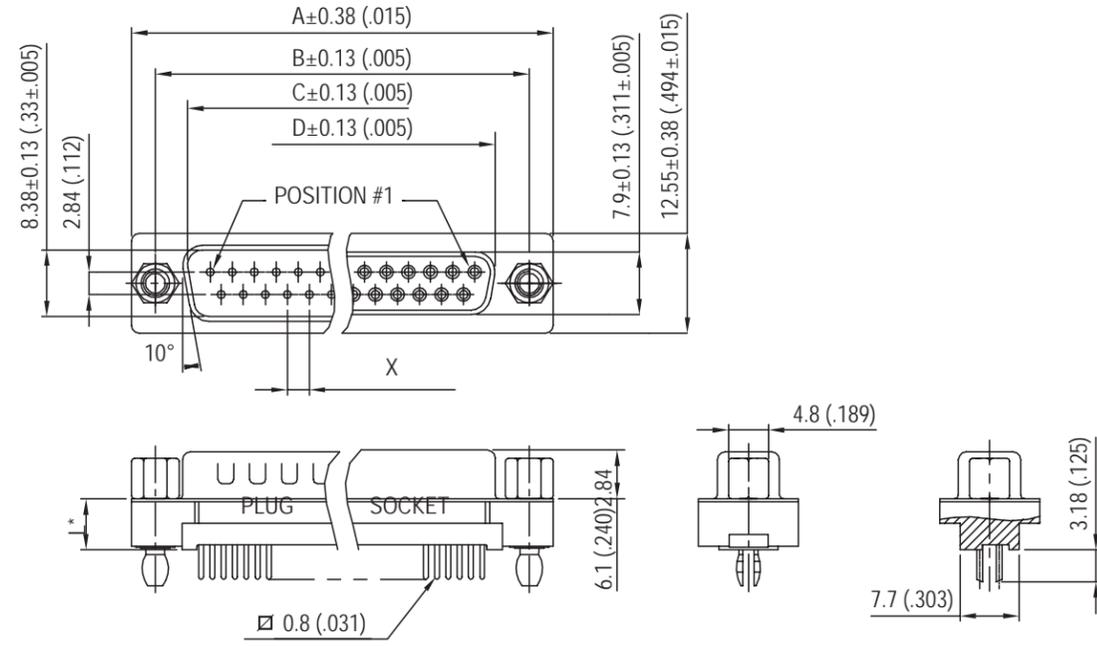

\*see chart "how to order"

Recommended P.C.B.Layout

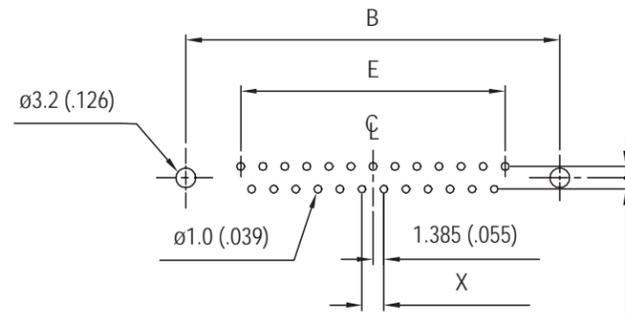

Nb OF CONTACTS	DIMENSIONS mm (inch)					
	A	B	C	D	E	X
9	30.84 (1.21)	24.99 (.984)	16.92 (.666)	16.26 (.640)	11.08 (.436)	2.74
15	39.24 (1.54)	33.32 (1.31)	25.25 (.994)	24.56 (.967)	19.39 (.763)	2.74
25	53.04 (2.09)	47.04 (1.85)	38.96 (1.53)	38.38 (1.51)	33.24 (1.31)	2.77
37	69.34 (2.73)	63.50 (2.50)	55.42 (2.18)	54.76 (2.16)	49.86 (1.96)	2.77

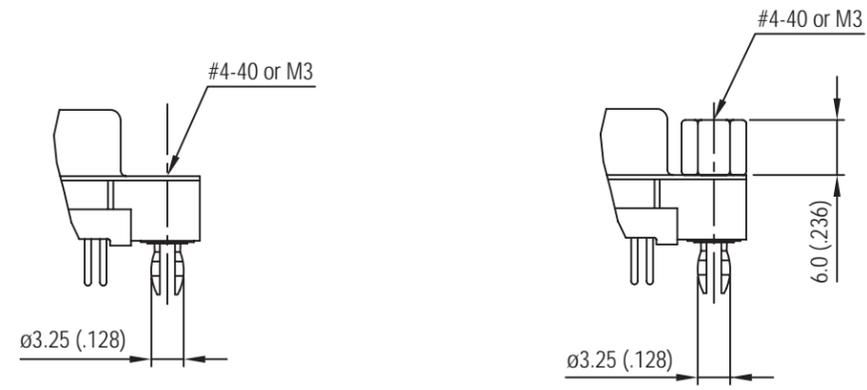

Standoff boardlock  
**RM5**

Standoff boardlock  
**RM8**

How to order

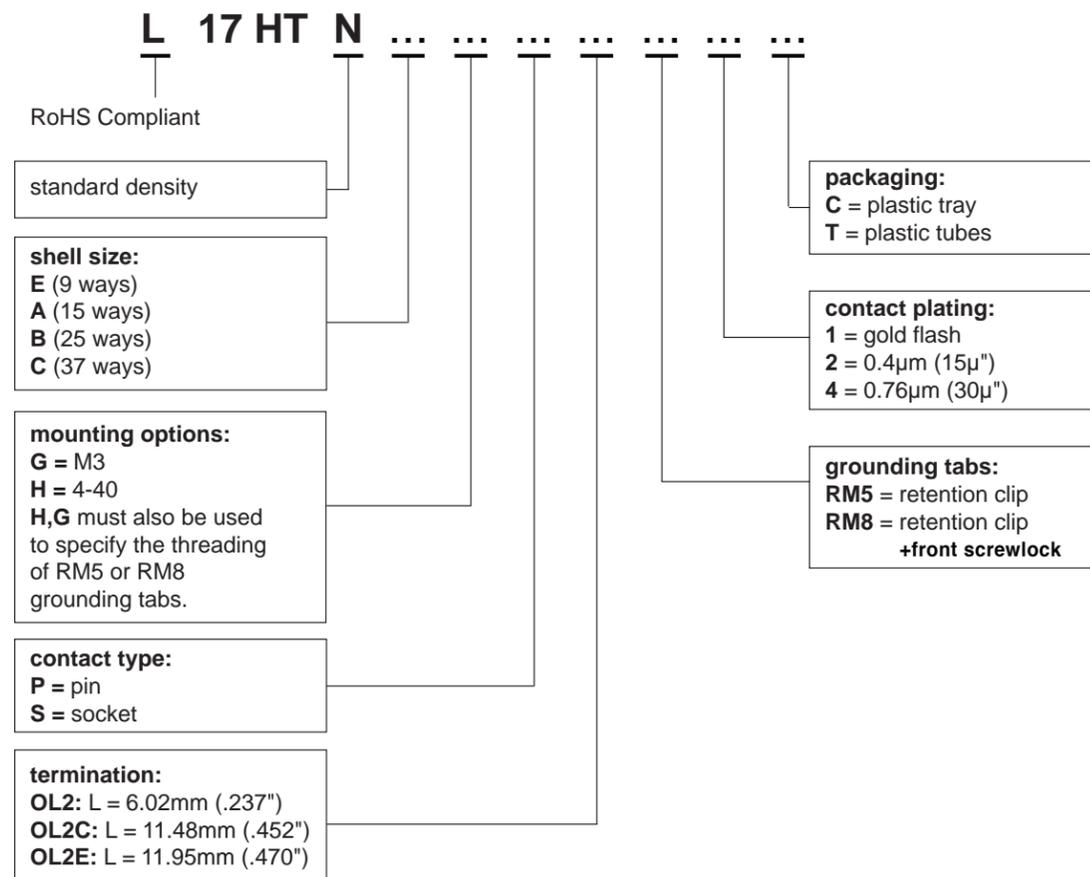

For special request, please consult factory

# HT

D-Sub connectors - Stamped and Formed Contacts

## RIGHT ANGLE HIGH TEMPERATURE CONNECTORS FOOTPRINT 14.99mm (.590")

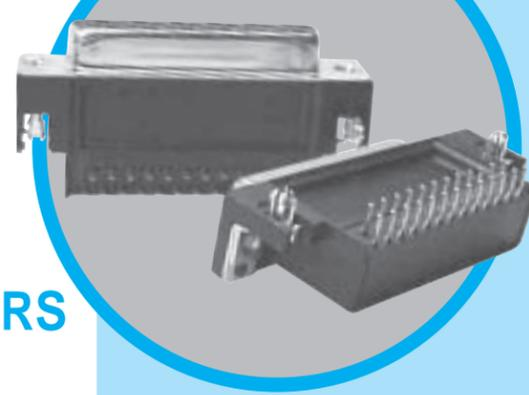

CHARACTERISTICS

### Specifications

- Connectors according to MIL C24308

Materials and Platings	
<b>Shells</b>	Steel, tin over nickel plating
<b>Insulator</b>	Glass-filled thermoplastic, UL 94V-0
<b>Contacts</b>	Copper alloy, selective gold plating
<b>Rear insert</b>	Brass with nickel plating
<b>Screwlock</b>	Brass with nickel plating
<b>Grounding clip</b>	Copper alloy with tin plating

Electrical Data	
<b>Current rating</b>	5A
<b>Voltage rating</b>	600V AC/rms 50Hz
<b>Withstanding voltage</b>	1000V AC/rms 50Hz for one minute
<b>Insulation resistance</b>	5000MΩ
<b>Contact resistance</b>	10mΩ max

Climatic Data	
<b>Operating temperature</b>	-55°C to +150°C, resist to short term (30s) at 260°C

Mechanical Data		
<b>Mating and unmating force</b>		
Unit: kg ( lb)		
No. of Cts	Mate (max)	Unmate (min)
9	3.05 (6.74)	0.36 (0.79)
15	5.09 (11.24)	0.46 (1.01)
25	8.44 (18.66)	0.81 (1.8)
37	12.51 (27.65)	1.1 (2.47)
<b>Standard plating thicknesses</b>		
<ul style="list-style-type: none"> <li>• gold flash</li> <li>• 0.4 μm (15μ") gold</li> <li>• 0.76 μm (30μ") gold</li> </ul>		

DESCRIPTION

The Amphenol "HT" series allows the customers to use through hole connectors with reflow soldering process.

This series gives you Amphenol's high standards of quality and reliability to meet all of your commercial requirements

*Economical  
right angle PCB,  
high temperature  
connectors*

APPLICATIONS

- Industrial
- Telecom
- Any industry standard I / O connections

HT / E16



**Amphenol**

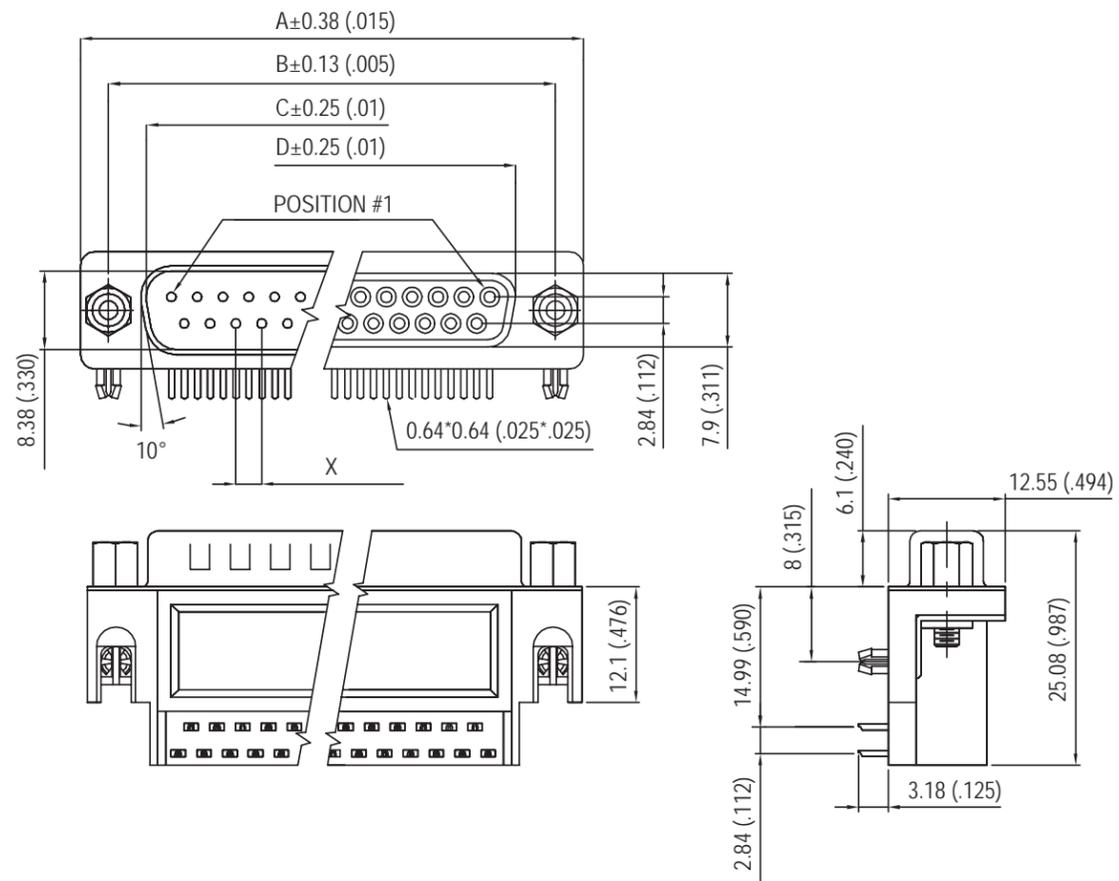

**Recommended P.C.B.Layout**

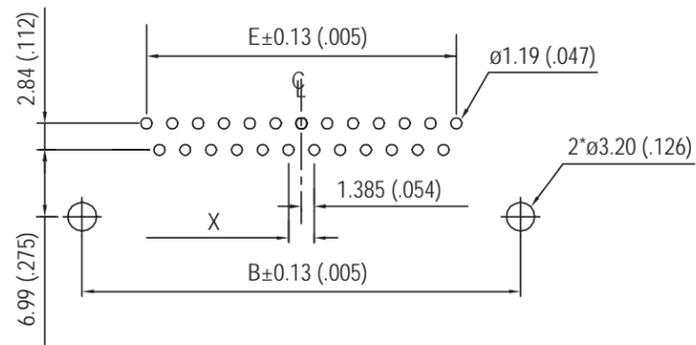

Nb OF CONTACTS	DIMENSIONS mm (inch)					
	A	B	C	D	E	X
9	30.84 (1.214)	24.99 (.984)	16.92 (.666)	16.26 (.640)	11.08 (.436)	2.74
15	39.24 (1.545)	33.32 (1.312)	25.25 (.994)	24.56 (.967)	19.39 (.763)	2.74
25	53.04 (2.088)	47.04 (1.852)	38.96 (1.534)	38.30 (1.508)	33.24 (1.309)	2.77
37	69.34 (2.730)	63.50 (2.500)	55.42 (2.182)	54.76 (2.156)	49.86 (1.963)	2.77

Panel mounting option

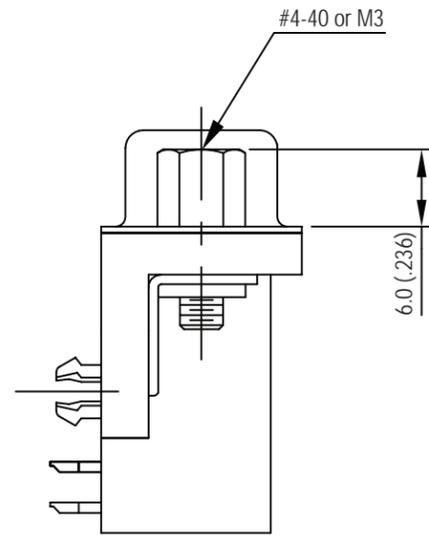

Front female screwlock  
4F/3F

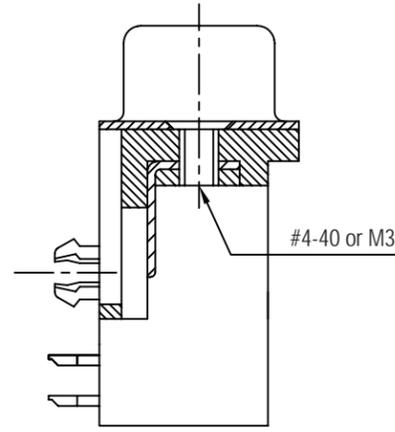

Threaded rear insert  
4R/3R

HOW TO ORDER

How to order

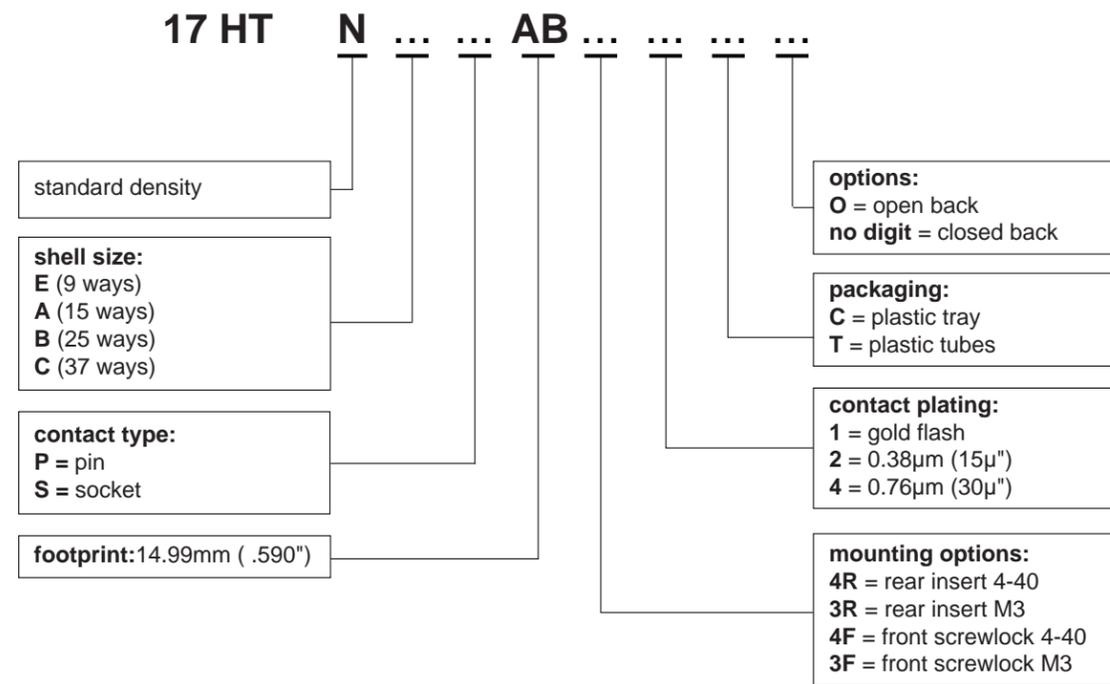

For special request, please consult factory

HT / E16



## RIGHT ANGLE HIGH TEMPERATURE CONNECTORS



CHARACTERISTICS

### Specifications

- Connectors according to MIL C24308

Materials and Platings	
Shell	Steel, tin over nickel plating
Insulator	Glass-filled thermoplastic, UL 94V-0
Contacts	Copper alloy, selective gold plating
Rear insert	Brass, tin over nickel plating
Screwlock	Brass, tin over nickel plating
Grounding clip	Copper alloy with tin plating

Electrical Data	
Current rating	5A
Voltage rating	600V AC/rms 50Hz
Withstanding voltage	1000V AC/rms 50Hz for one minute
Insulation resistance	5000MΩ
Contact resistance	10mΩ max

Climatic Data	
Operating temperature	-55°C to +150°C, resist to short term soldering at 260°C for 20sec.

Mechanical Data		
<b>Mating and unmating force</b>		
Unit: kg ( lb)		
No. of Cts	Mate (max)	Unmate (min)
9	3.05 (6.74)	0.36 (0.79)
15	5.09 (11.24)	0.46 (1.01)
25	8.44 (18.66)	0.81 (1.8)
37	12.51 (27.65)	1.1 (2.47)
<b>Standard plating thicknesses</b>		
<ul style="list-style-type: none"> <li>• Gold flash</li> <li>• 0.4 μm (15μ") Gold</li> <li>• 0.76 μm (30μ") Gold</li> </ul>		

DESCRIPTION

The Amphenol HTN series allows the use of a through hole connector with reflow soldering process. This series gives you Amphenol's high standard of quality and reliability, to meet all of your commercial requirements.

*Economical  
right angle PDB,  
high temperature  
connectors*

APPLICATIONS

- Industrial
- Telecom
- Any industry standard I / O connections

HTN / E17

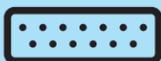

Amphenol

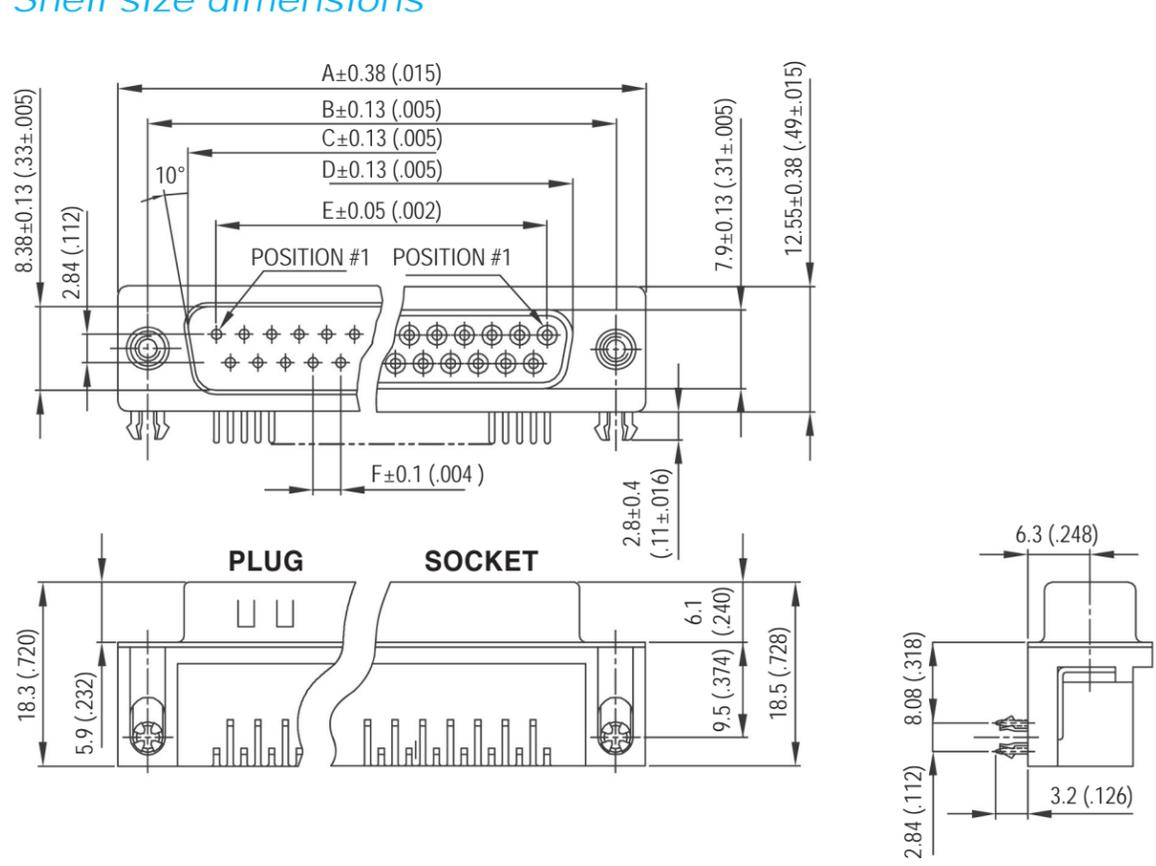

Nb OF CONTACTS	DIMENSIONS mm (inch)					
	A	B	C	D	E	F
9	30.81 (1.21)	24.99 (.98)	16.92 (.67)	16.24 (.64)	11.09 (.44)	2.74 (.108)
15	39.14 (1.54)	33.32 (1.31)	25.25 (.99)	24.56 (.97)	19.39 (.76)	2.74 (.108)
25	53.04 (2.09)	47.04 (1.85)	38.96 (1.53)	38.38 (1.51)	33.24 (1.31)	2.77 (.109)
37	69.32 (2.73)	63.50 (2.50)	55.42 (2.18)	54.76 (2.16)	49.86 (1.96)	2.77 (.109)

Recommended P.C.B.Layout

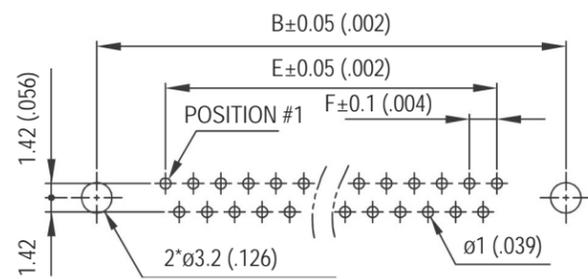

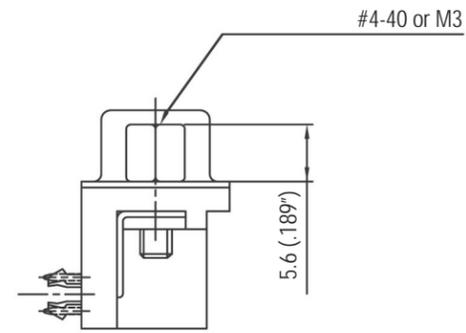

Front female screwlock  
4F/3F

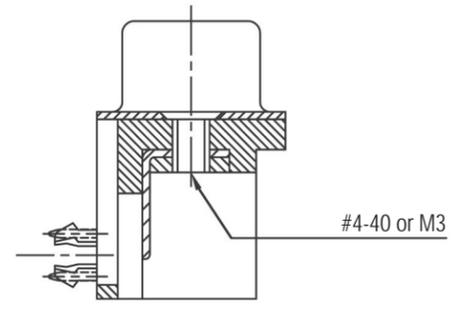

Threaded rear insert  
4R/3R

How to order

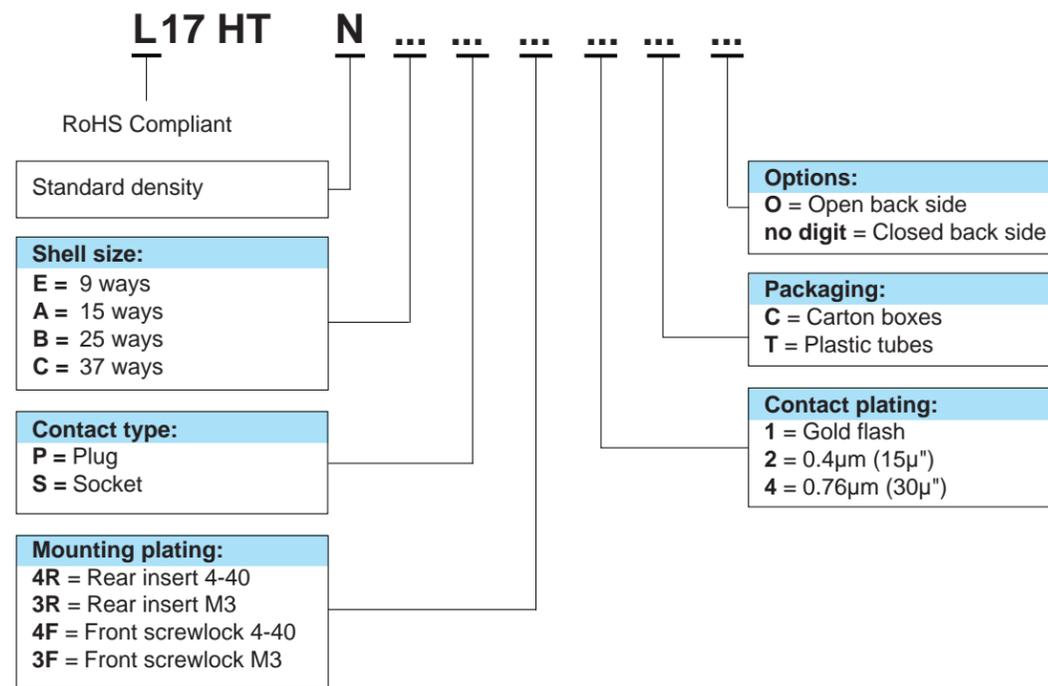

*For special request, please consult factory*



# D-DF

D-Sub connectors - Screw-machined Contacts

## FIXED MACHINED CONTACT CONNECTOR



CHARACTERISTICS

### Specifications

- Connectors according to MIL C24308 - NFC93425-HE5

Materials and Platings	
<b>Shells</b>	Steel tinned with dimples on plug connector
<b>Insulator</b>	Glass-filled thermoplastic, UL 94V-0
<b>Rear insert</b>	Brass, 3µm up to 5µm (118µ" up to 197µ") tinned over nickel 2µm up to 3µm (78µ" up to 118µ")
<b>Boardlock</b>	Tin plating 4µm up to 6µm (157µ" up to 236µ") over nickel 2µm up to 3µm (78µ" up to 118µ")
<b>Screwlock</b>	Brass, 6µm up to 10µm (236µ" up to 394µ") tinned over nickel 2µm up to 3µm (78µ" up to 118µ")
<b>Contacts</b>	<b>D:</b> brass <b>DF:</b> pin = brass socket = copper alloy <b>Right angle version:</b> full gold plating over 2µm to 3µm nickel <b>Straight version:</b> full gold plating over 2µm up to 3µm (78µ" up to 118µ") nickel

Electrical Data	
<b>Current rating</b>	7.5A
<b>Voltage rating</b>	300V AC/rms 50Hz
<b>Withstanding voltage</b>	1000V AC/rms 50Hz for one minute
<b>Insulation resistance</b>	5000MΩ
<b>Contact resistance</b>	<b>D:</b> 8.5mΩ max <b>DF:</b> 5mΩ max

Climatic Data	
<b>Operating temperature</b>	<b>D / DF:</b> -55°C to + 125°C
<b>Salt spray</b>	48 hours
<b>Humidity</b>	<b>D:</b> 21 days (40°C - 95% HR) <b>DF:</b> 56 days (40°C - 95% HR)

Mechanical Data		
Mating and unmating force		
Unit: kg ( lb)		
No. of Cts	Mate (max)	Unmate (min)
9 (size E)	3.05 (6.74)	0.36 (0.79)
15 (size A)	5.09 (11.24)	0.46 (1.01)
25 (size B)	8.44 (18.66)	0.81 (1.8)
37 (size C)	12.51 (27.65)	1.1 (2.47)
50 (size D)	14.65 (32.38)	1.6 (3.56)

DESCRIPTION

Amphenol's 17D and 17DF series fixed contact D-Subminiature connector is suitable for industrial or telecom use.

The machined contact provide stability and reliability.

This series offers the broadest range of termination options in the Amphenol line.

*Connectors  
for industrial  
and  
telecom use*

APPLICATIONS

- Medical
- Industrial
- Telecom
- Any industry standard I / O connections

D-DF / E18

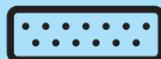

Amphenol

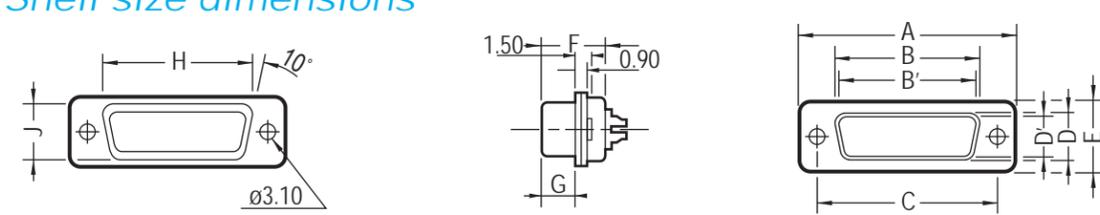

Shell size	Contact P: Pin S: Socket	A ±0.25 (±.010)	B 0/-0.20 (0/-0.008)	B' +0.20/0 (+.008/0)	C ±0.10 (±.004)	D 0/-0.25 (0/-0.010)	D' +0.25/0 (+.010/0)	E ±0.20 (±.008)	F +0.05/-0.20 (+.002/-0.008)	F' +0.10/-0.20 (+.004/-0.008)	G +0.10/-0.20 (+.004/-0.008)	G' ±0.10 (±.004)	H +0.10/-0.40 (+.004/-0.016)	J 0/-0.50 (0/-0.020)
E	P	30.7 (1.209")		16.8 (.661")	25.0 (.984")		8.2 (.323")	12.4 (.488")		10.9 (.429")		5.9 (.232")	19.4 (.764")	11.0 (.433")
	S		16.4 (.646")			8.0 (.315")			11.1 (.437)		6.2 (.244")			
A	P	39.0 (1.535")		25.1 (.988")	33.3 (1.311")		8.2 (.323")	12.4 (.488")		10.9 (.429")		5.9 (.232")	27.7 (1.091")	11.0 (.433")
	S		24.8 (.976")			8.0 (.315")			11.1 (.437)		6.2 (.244")			
B	P	52.9 (2.083")		38.8 (1.528")	47.0 (1.850")		8.2 (.323")	12.4 (.488")		11.0 (.433")		5.8 (.228")	41.4 (1.630")	11.0 (.433")
	S		38.5 (1.513")			8.0 (.315")			11.1 (.437)		6.2 (.244")			
C	P	69.2 (2.724")		55.3 (2.177")	63.5 (2.500")		8.2 (.323")	12.4 (.488")		11.0 (.433")		5.8 (.228")	57.9 (2.280")	11.0 (.433")
	S		54.9 (2.161")			8.0 (.315")			11.1 (.437)		6.2 (.244")			
D	P	66.8 (2.630")		52.7 (2.075")	61.1 (2.406")		11.0 (.433")	15.2 (.598")		11.0 (.433")		5.8 (.228")	55.5 (2.185")	13.8 (.543")
	S		52.5 (2.067")			10.9 (.429")			11.1 (.437)		6.2 (.244")			

### Panel cutouts

Optimal cutout for rear mounting

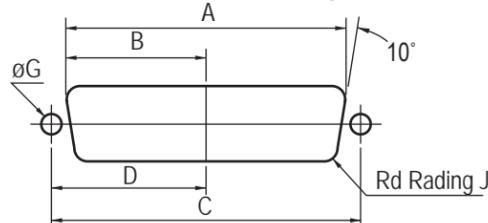

Standard cutout

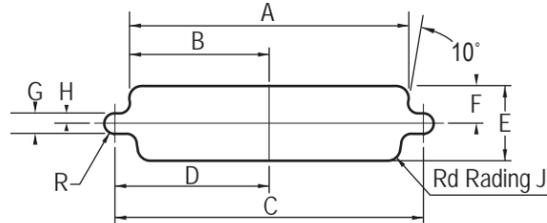

Shell size	Mounting method	A ±0.20 (±.008)	B ±0.20 (±.008)	C ±0.20 (±.008)	D ±0.20 (±.008)	E ±0.20 (±.008)	F ±0.20 (±.008)	G ±0.20 (±.008)	H ±0.20 (±.008)	J ±0.20 (±.008)
E	Front	22.2 (.874")	11.1 (.437")	25.0 (.984")	12.5 (.492")	13.0 (.512")	6.5 (.256")	3.0 (.118")	1.5 (.059")	2.1 (.083")
	Rear	20.5 (.807")	10.2 (.402")							3.4 (.134")
A	Front	30.5 (1.201")	15.3 (.602")	33.3 (1.311")	16.7 (.657")	13.0 (.512")	6.5 (.256")	3.0 (.118")	1.5 (.059")	2.1 (.083")
	Rear	28.8 (1.134")	14.4 (.567")							3.4 (.134")
B	Front	44.3 (1.744")	22.1 (.870")	47.0 (1.850")	23.5 (.925")	13.0 (.512")	6.5 (.256")	3.0 (.118")	1.5 (.059")	2.1 (.083")
	Rear	42.5 (1.673")	21.3 (.839")							3.4 (.134")
C	Front	60.7 (2.390")	30.4 (1.197")	63.5 (2.500")	31.7 (1.248")	13.0 (.512")	6.5 (.256")	3.0 (.118")	1.5 (.059")	2.1 (.083")
	Rear	59.1 (2.327")	29.5 (1.161")							3.4 (.134")
D	Front	58.3 (2.295")	29.2 (1.150")	61.1 (2.406")	30.6 (1.205")	15.8 (.622")	7.9 (.311")	3.0 (.118")	1.5 (.059")	2.1 (.083")
	Rear	56.3 (2.217")	28.2 (1.110")							3.4 (.134")

MIL Footprint

without bracket:

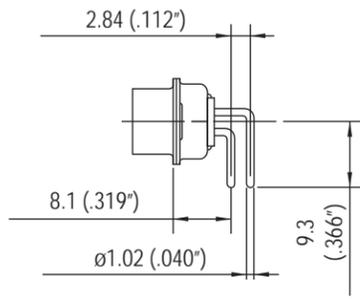

C

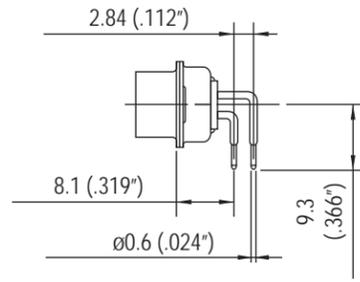

A4

plastic bracket:

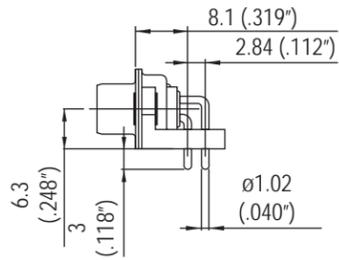

AJ3

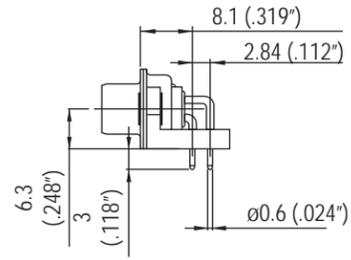

AJ4

metal bracket:

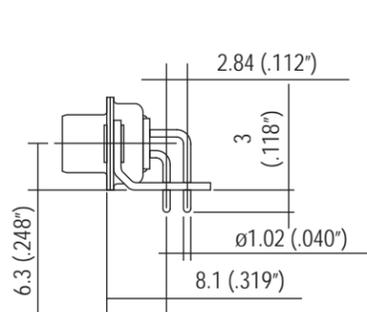

A

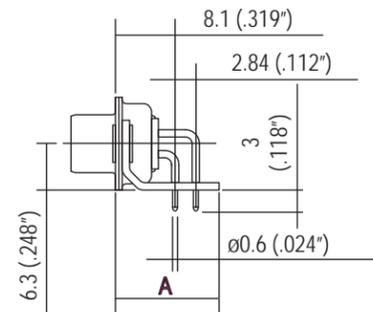

AM4: A=13.2mm  
AZ4: A=11.5mm

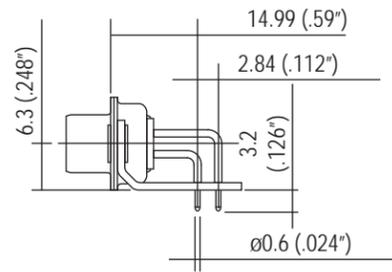

AM4B

50 contacts:

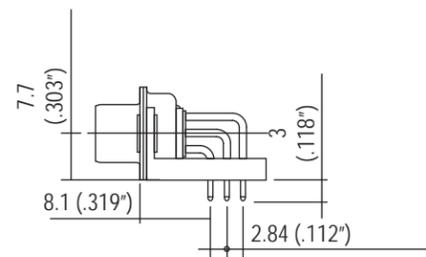

OVERALL DIMENSION

D-DF / E18



**European footprint**

**without bracket:**

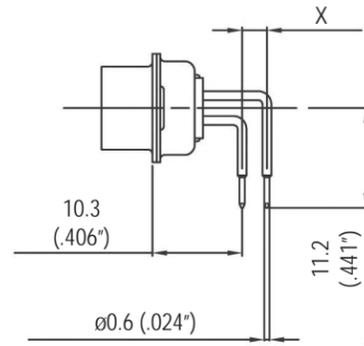

**1AON: X=2.54mm**  
**1BON: X=2.84mm**

**plastic bracket:**

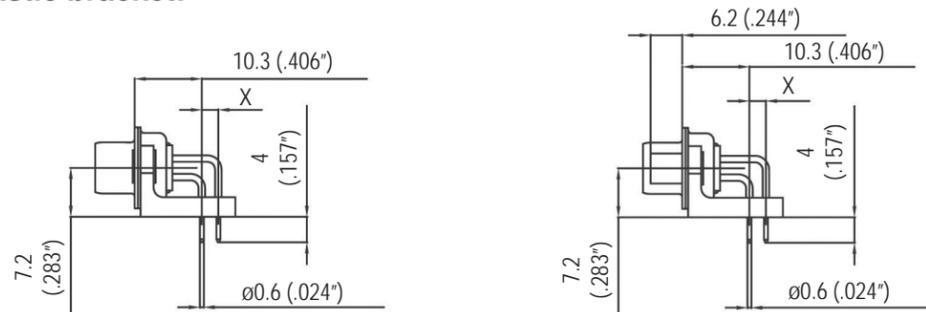

**1APN: X=2.54mm**  
**1BPN: X=2.84mm**

**1AUN: X=2.54mm**  
**1BUN: X=2.84mm**

**metal bracket:**

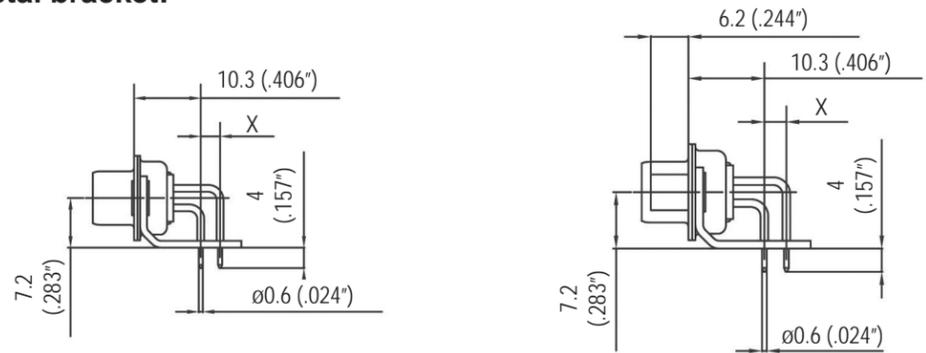

**1AMN: X=2.54mm**  
**1BMN: X=2.84mm**

**1ATN: X=2.54mm**  
**1BTN: X=2.84mm**

**50 contacts:**

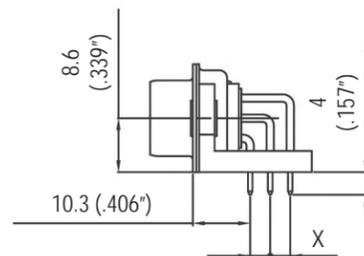

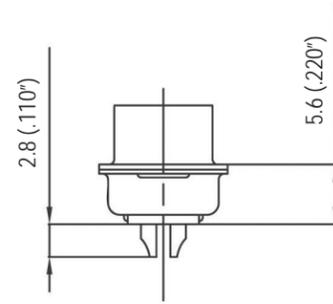
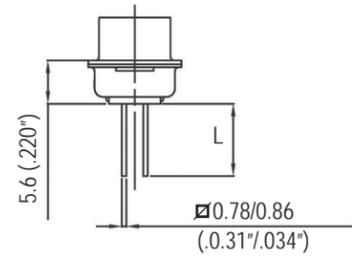
**Solder Cup:****Wire Wrap:**

termination	Nb of wraps	L
<b>F179</b>	2	9.6mm (.378")
<b>F179A</b>	3	13mm (.512")

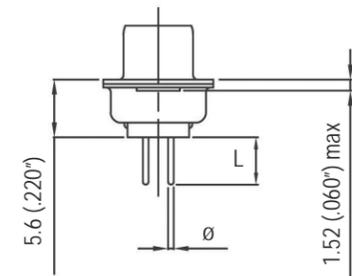
**Straight PCB:**

termination	$\varnothing$	L
<b>U</b>	0.6mm (.024")	3.2mm (.126")
<b>V</b>	1.02mm (.040")	2.4mm (.095")
<b>T</b>	0.6mm (.024")	4mm (.157")
<b>OL2</b>	0.6mm (.024")	5.5mm (.217")

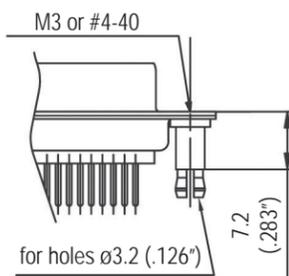
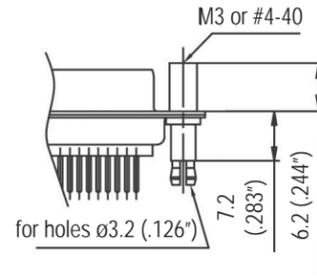
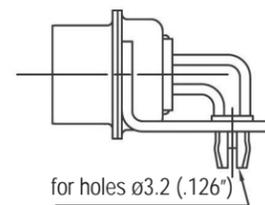
**Grounding tabs:****For straight termination****RM5****RM8****For R/A termination****FOR PCB 1.6****RM6**



Panel mounting option

For straight and R/A termination

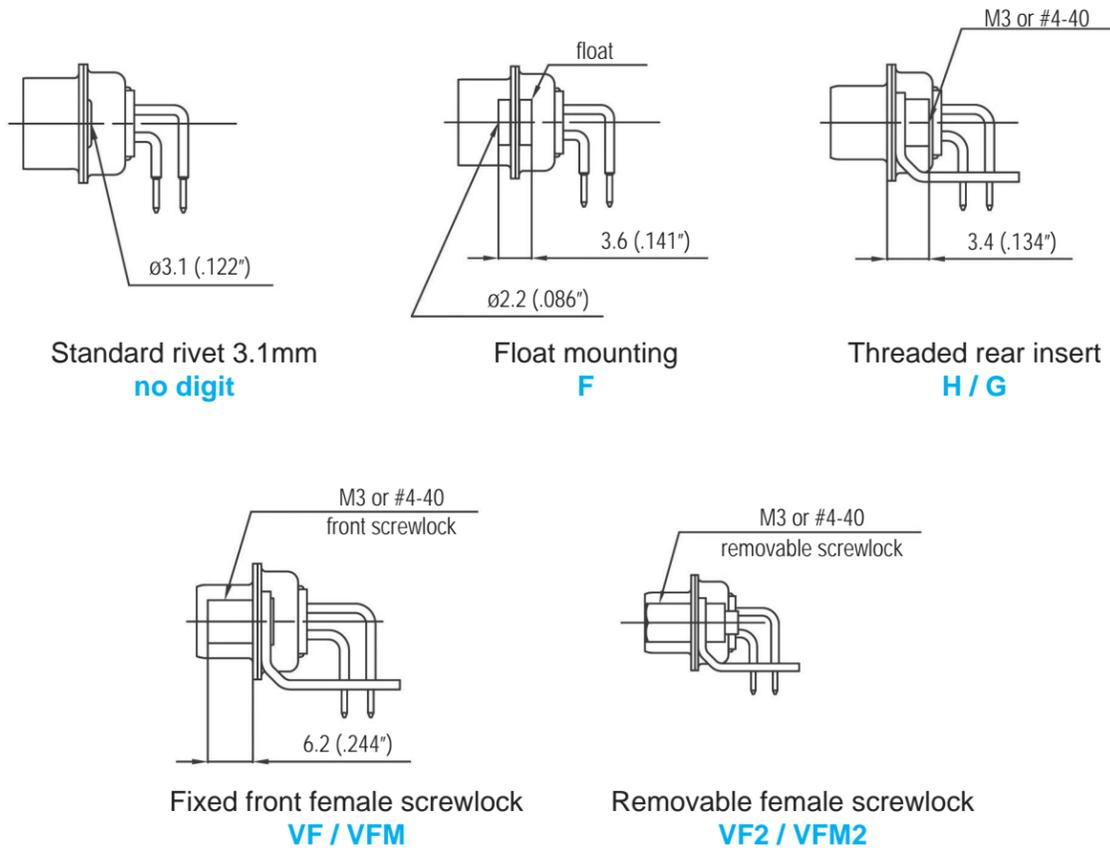

Recommended PCB Layout

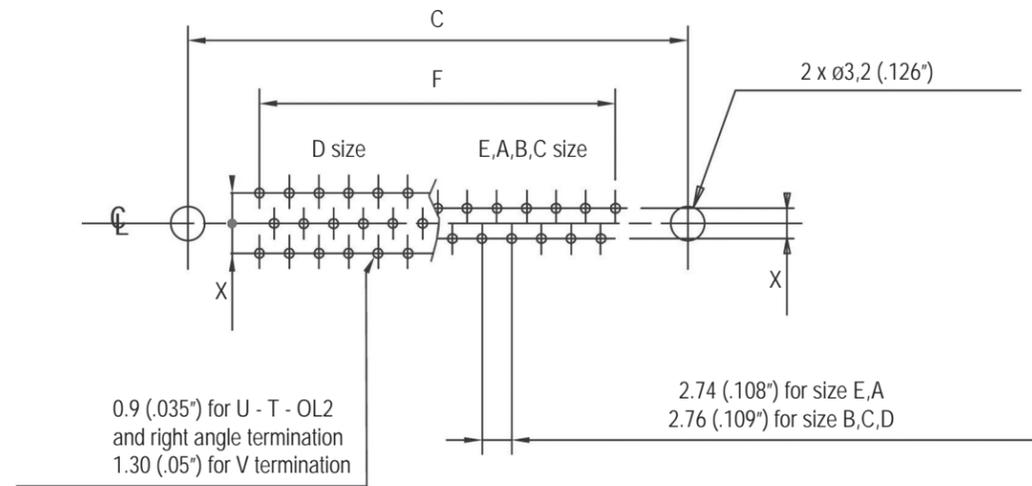

For straight PCB: X = 2.84mm (.112")  
 For right angle PCB: MIL: X = 2.84mm (.112")  
 European: X = 2.54mm (.100"), 2.84mm in option

	size E	size A	size B	size C	size D
<b>C±0,1 (.004)</b>	25 (.984)	33.3 (1.311)	47 (1.85)	63.5 (2.5)	61.1 (2.406)
<b>F±0,05 (.002)</b>	10.96 (.431)	19.18 (.755)	33.12 (1.304)	49.68 (1.956)	44.2 (1.74)

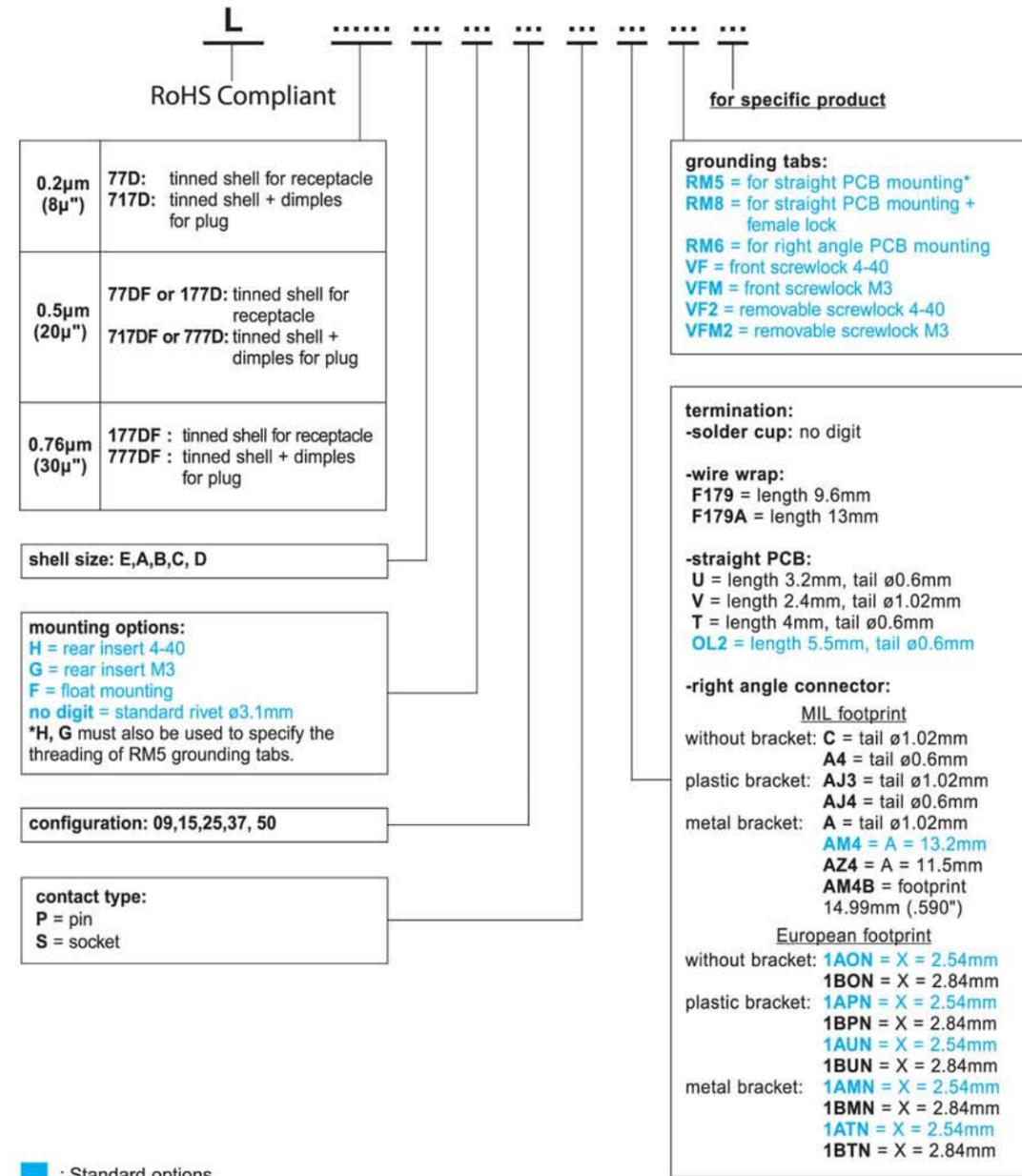

**For special request, please consult factory**

**D-DF / E18**



## RIGHT ANGLE HIGH DENSITY CONNECTORS

### Specifications

- Connectors according to: MIL C24308

Materials and Platings	
<b>Shells</b>	Steel, tin over nickel plating
<b>Body</b>	Glass filled thermoplastic, UL 94V-0
<b>Contacts</b>	Copper alloy, selective gold plating
<b>Rear insert</b>	Brass with nickel plating
<b>Screwlock</b>	Brass with nickel plating
<b>Grounding clip</b>	Copper alloy with tin plating

Electrical Data	
<b>Current rating</b>	3A
<b>Voltage rating</b>	300V AC/rms 50Hz
<b>Withstanding voltage</b>	1000V AC/rms 50HZ for one minute
<b>Insulation resistance</b>	5000MΩ
<b>Contact resistance</b>	10mΩ Max.

Climatic Data	
<b>Operating temperature</b>	-55°C to +125°C

Mechanical Data		
<b>Mating and unmating force</b>		
Unit: kg (lb)		
No. of Cts	Mate (max)	Unmate (min)
15	3.81 (8.42)	0.52 (1.14)
26	5.95 (13.16)	1.05 (2.32)
44	9.26 (20.46)	1.37 (3.02)
62	13.48 (29.78)	1.76 (3.88)
<b>Standard plating thickness</b>		
<ul style="list-style-type: none"> <li>• gold flash</li> <li>• 0.4µm (15µ") gold</li> <li>• 0.76µm (30µ") gold</li> </ul>		

### DESCRIPTION

Amphenol's high density D-Sub connectors complement Amphenol's extensive D-Sub connector line. This line offers many superior features, high performance level and low installation cost.

The decreased contact spacing accommodates greater signal density in comparison to conventional D-Sub connectors.

*Economical  
right angle PCB*

### APPLICATIONS

- Industrial
- Telecom
- Any industry standard I/O connections

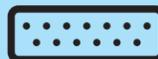

**Amphenol**

HD / E19

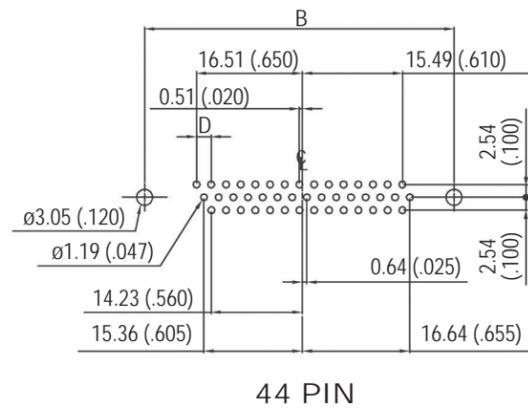
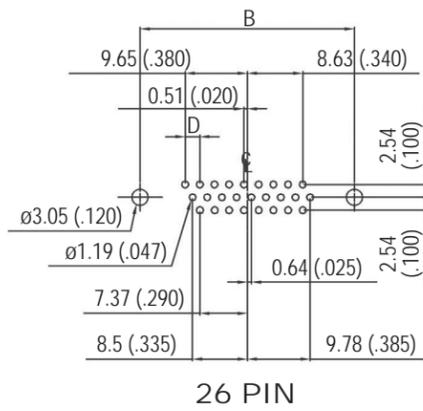
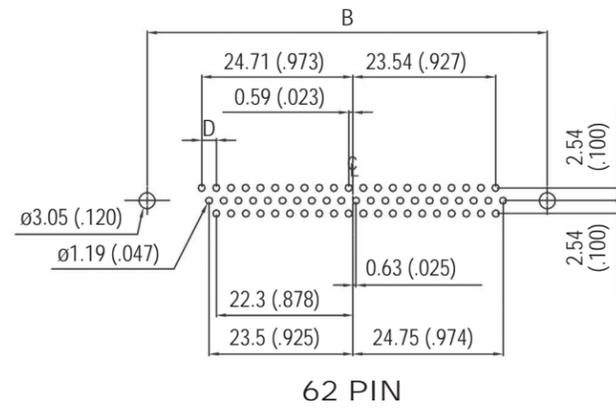
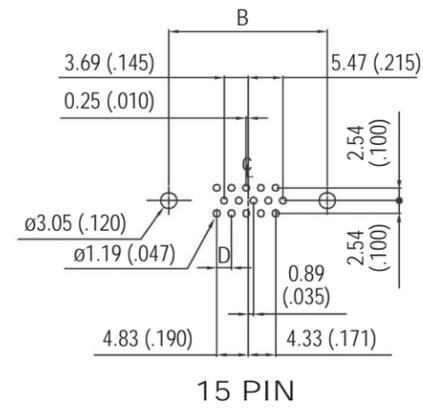

Panel mounting option

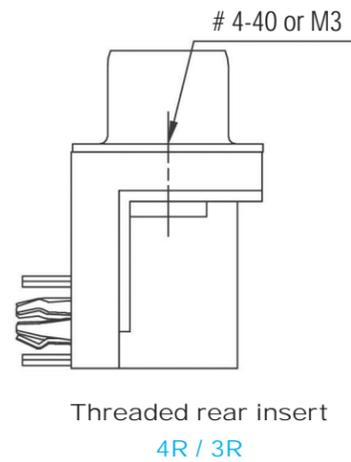
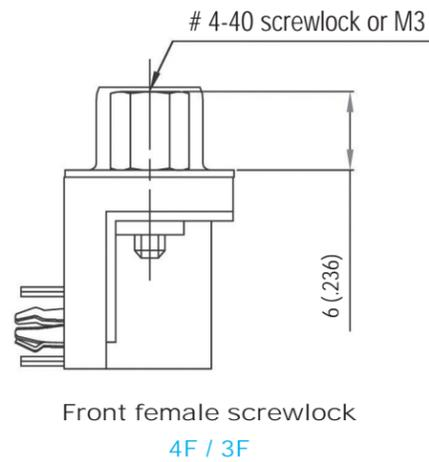

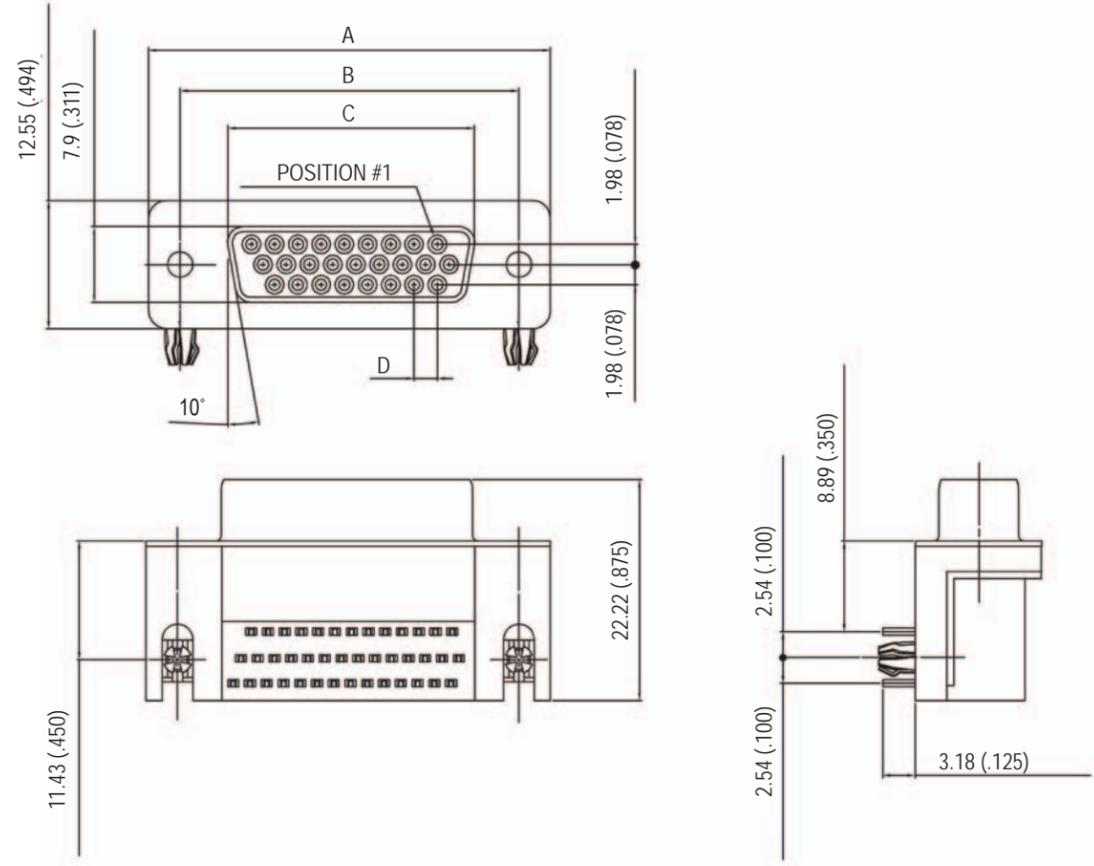

NB OF CONTACTS	DIMENSIONS mm (inch)			
	A	B	C	D
15	30.84 (1.214)	24.99 (.984)	16.26 (.640)	2.29 (.090)
26	39.24 (1.545)	33.32 (1.312)	24.56 (.967)	2.29 (.090)
44	53.04 (2.088)	47.04 (1.852)	38.30 (1.508)	2.29 (.090)
62	69.34 (2.730)	63.50 (2.500)	54.76 (2.156)	2.41 (.095)

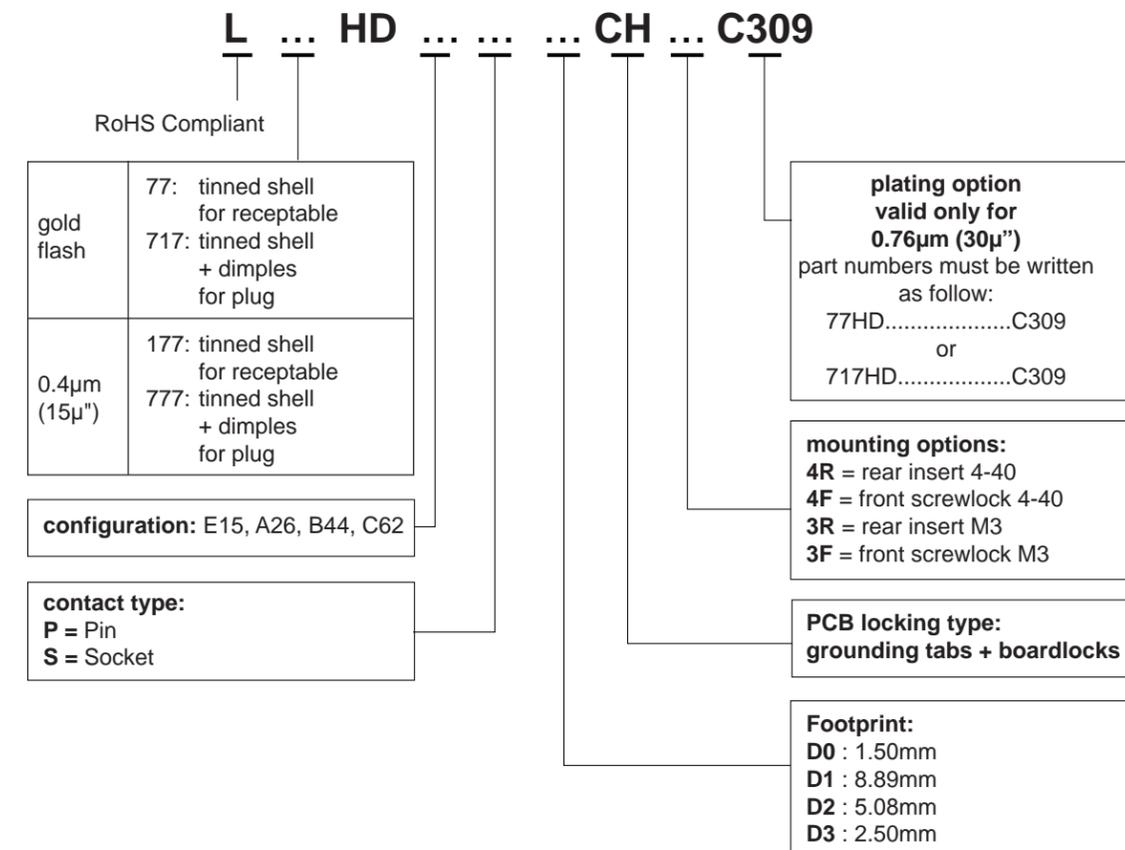

**For special request, please consult factory**

Do not hesitate to contact us for further information



**Amphenol**  
**Amphenol IT & Communication Products**  
 Block A3/A4, The 4th Industrial District of  
 Industrial Headquarters, Dong Keng Road  
 Gong Ming Town, Shen Zhen China  
 Fax:+86(0)755 2754 9955  
**Technical Support**  
 Tel:+86(0)755 2717 7945  
 Info-dsub@amphenol.com.cn  
 http://www.dsubconnector.com

# G517-A

D-Sub connectors - Stamped and Formed Contacts

## GENDER CHANGER

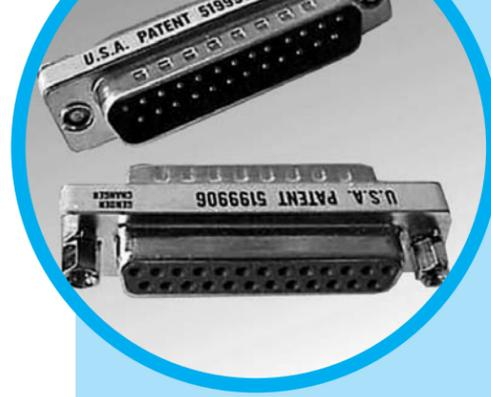

CHARACTERISTICS

### Specifications

- Connectors according to MIL C24308

Materials and Platings	
<b>Shells</b>	Steel, 2.54µm (100µ") tin over 1.27µm (50µ") nickel plated
<b>Insulator</b>	Glass-filled nylon, UL 94V-0
<b>Pin contacts</b>	Brass, gold plated over 1.27µm (50µ") nickel
<b>Screwlock</b>	Brass, 2.54µm (100µ") min. nickel plated

Electrical Data	
<b>Current rating</b>	5A
<b>Voltage rating</b>	250V AC/rms 60Hz
<b>Withstanding voltage</b>	1000V AC/rms 60Hz for one minute
<b>Insulation resistance</b>	1000MΩ
<b>Contact resistance</b>	20mΩ max

Climatic Data	
<b>Operating temperature</b>	-55°C to +105°C

DESCRIPTION

These connectors allow you to change the gender of your cable assembly, and or panel D-Sub connectors.

This series gives you Amphenol's high standards of quality and reliability to meet all of your commercial requirements.

*Economical  
gender changer  
D-Sub's*

APPLICATIONS

- Industrial
- Telecom
- Any industry standard I/O connections

G517-A / E20

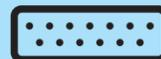

Amphenol

Male to male adaptor

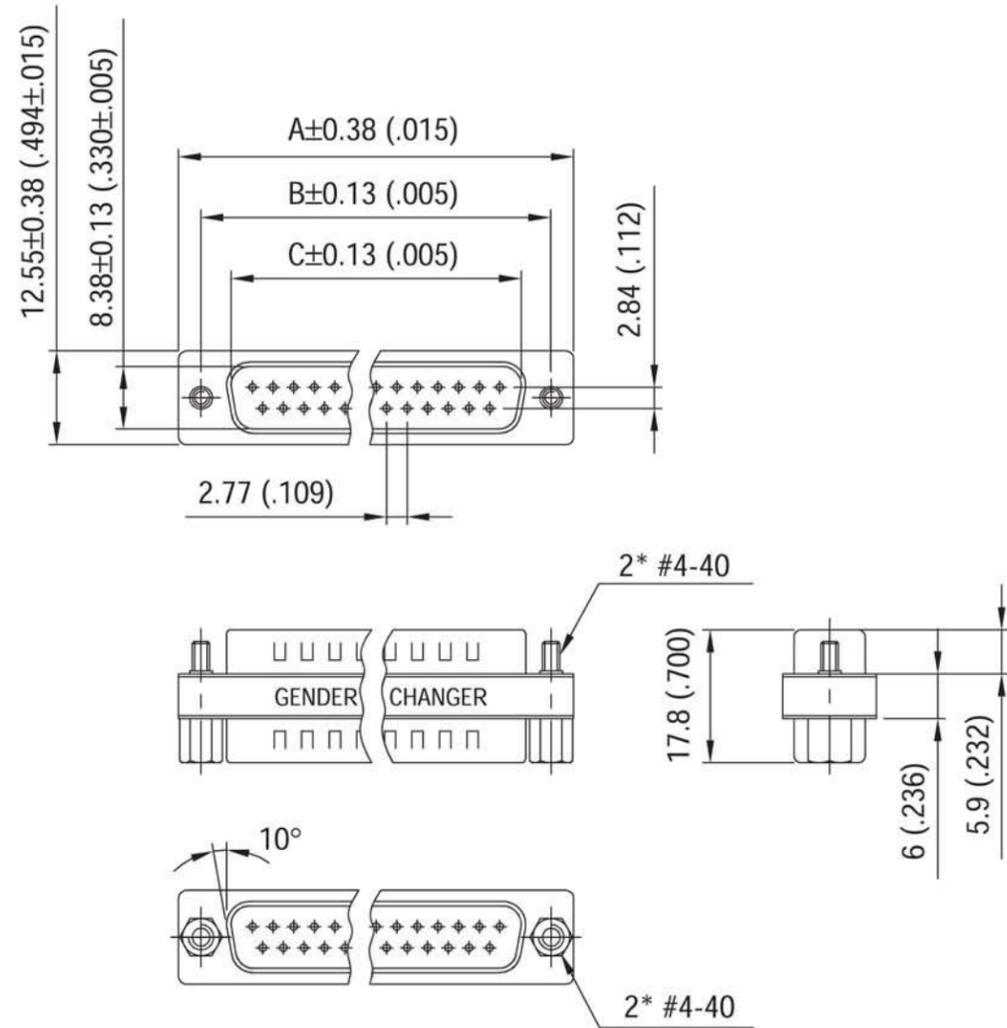

PAPT NUMBER	Nb OF CONTACTS	DIMENSIONS mm (inch)		
		A	B	C
L G517 97001	9	30.81 (1.21)	24.99 (.984)	16.92 (.666)
L G517 97002	15	39.14 (1.54)	33.32 (1.31)	25.25 (.994)
L G517 97003	25	53.04 (2.09)	47.04 (1.85)	38.96 (1.53)
L G517 97004	37	69.32 (2.73)	63.5 (2.50)	55.42 (2.18)



Male to female adaptor

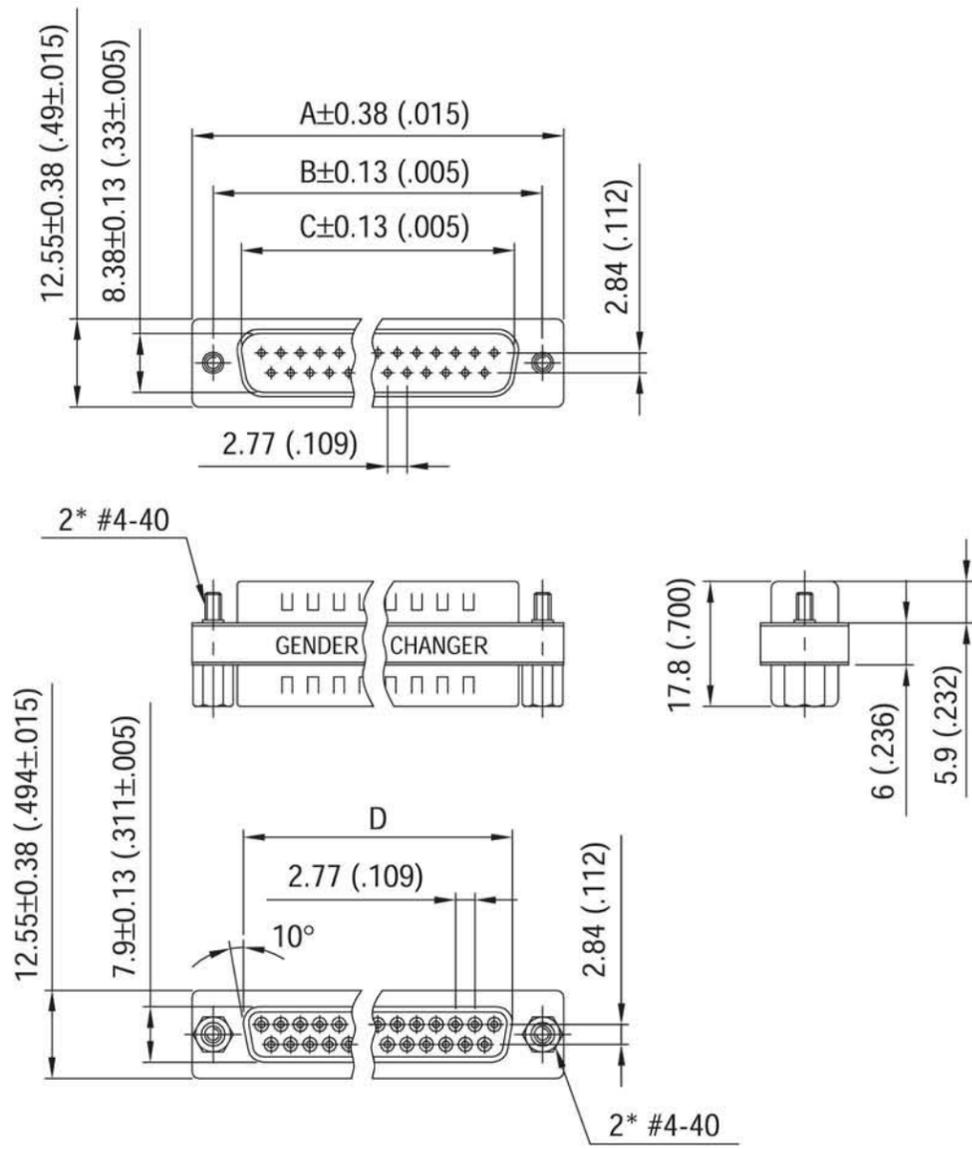

PAPT NUMBER	Nb OF CONTACTS	DIMENSIONS mm (inch)			
		A	B	C	D
L G517 97009	9	30.81 (1.21)	24.99 (.984)	16.92 (.666)	16.33 (.643)
L G517 97010	15	39.14 (1.54)	33.32 (1.31)	25.25 (.994)	24.66 (.971)
L G517 97011	25	53.04 (2.09)	47.04 (1.85)	38.96 (1.53)	38.38 (1.51)
L G517 97012	37	69.32 (2.73)	63.5 (2.50)	55.42 (2.18)	55.84 (2.20)

G517-A / E20

TECHNICAL DATA

Shell size dimensions  
Female to female adaptor

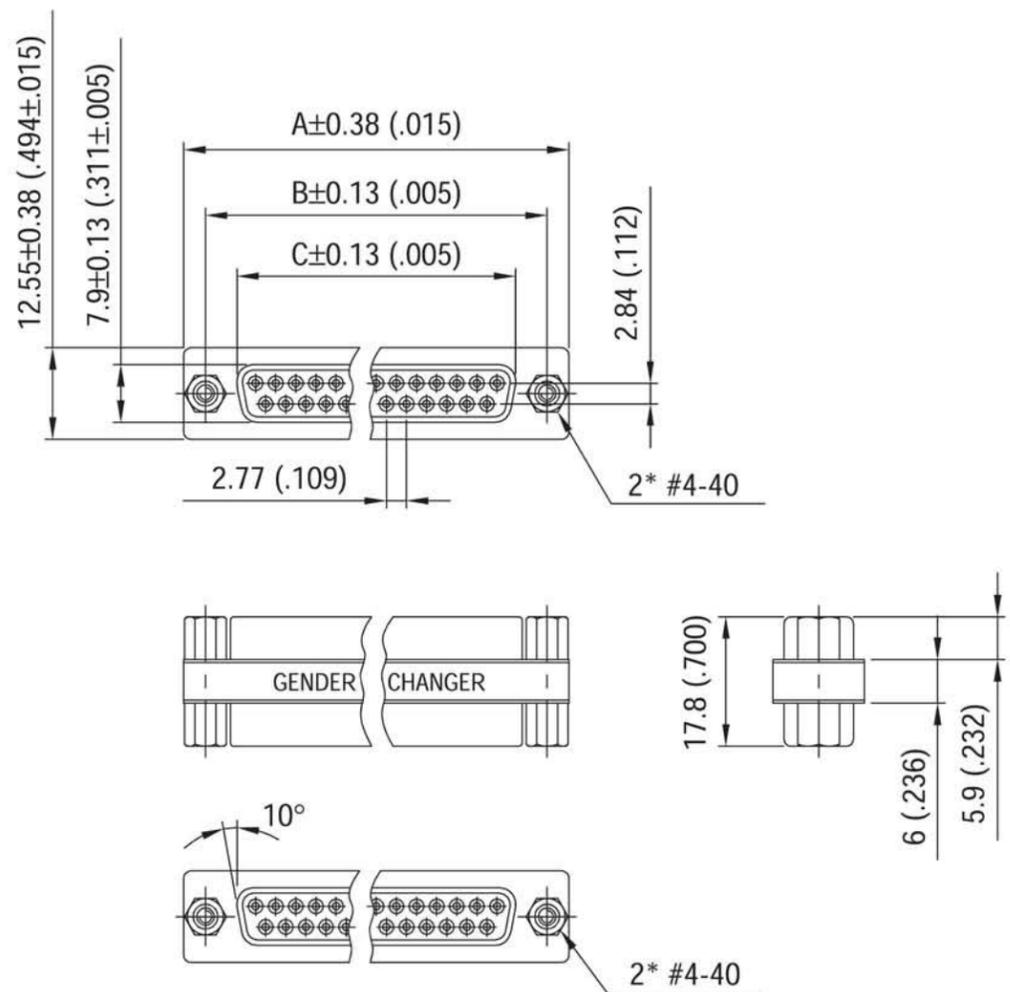

PART NUMBER	Nb OF CONTACTS	DIMENSIONS mm (inch)		
		A	B	C
L G517 97005	9	30.81 (1.21)	24.99 (.984)	16.33 (.643)
L G517 97006	15	39.14 (1.54)	33.32 (1.31)	24.66 (.971)
L G517 97007	25	53.04 (2.09)	47.04 (1.85)	38.38 (1.51)
L G517 97008	37	69.32 (2.73)	63.5 (2.50)	55.84 (2.20)

Do not hesitate to contact us for further information



**Amphenol**

**Amphenol IT & Communication Products**

Block A3/A4, The 4th Industrial District of  
Industrial Headquarters, Dong Keng Road  
Gong Ming Town, Shen Zhen China  
Fax: +86(0)755 2754 9955

**Technical Support**

Tel: +86(0)755 2717 7945  
Info-dsub@amphenol.com.cn  
<http://www.dsubconnector.com>

# G517-B

D-Sub connectors - Stamped and Formed Contacts

## ADAPTORS D-SUB TO D-SUB 9 TO 9 AND 25 TO 25



CHARACTERISTICS

### Specifications

- Connectors according to MIL C24308

Materials and Platings	
<b>Shells</b>	Steel, 2.54µm (100µ") tin over 1.27µm (50µ") nickel plated
<b>Insulator</b>	Glass-filled nylon, UL 94V-0
<b>Pin contacts</b>	Brass, gold plated over 1.27µm (50µ") nickel
<b>Socket Contact</b>	Phosphor bronze, gold plated over 1.27µm (50µ") nickel
<b>Overmold</b>	PVC, UL 94V-0
<b>Screw</b>	Brass with nickel plating

Electrical Data	
<b>Current rating</b>	5A
<b>Voltage rating</b>	250V AC/rms 60Hz
<b>Withstanding voltage</b>	1000V AC/rms 60Hz for one minute
<b>Insulation resistance</b>	1000MΩ
<b>Contact resistance</b>	20mΩ max

Climatic Data	
<b>Operating temperature</b>	-55°C to +105°C

DESCRIPTION

This series gives you Amphenol's high standards of quality and reliability to meet all of your commercial requirements.

*Economical  
D-Sub  
adaptors*

APPLICATIONS

- Industrial
- Telecom
- Any industry standard I / O connections

G517-B / E21

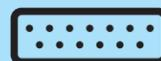

Amphenol

9-position to 9-position

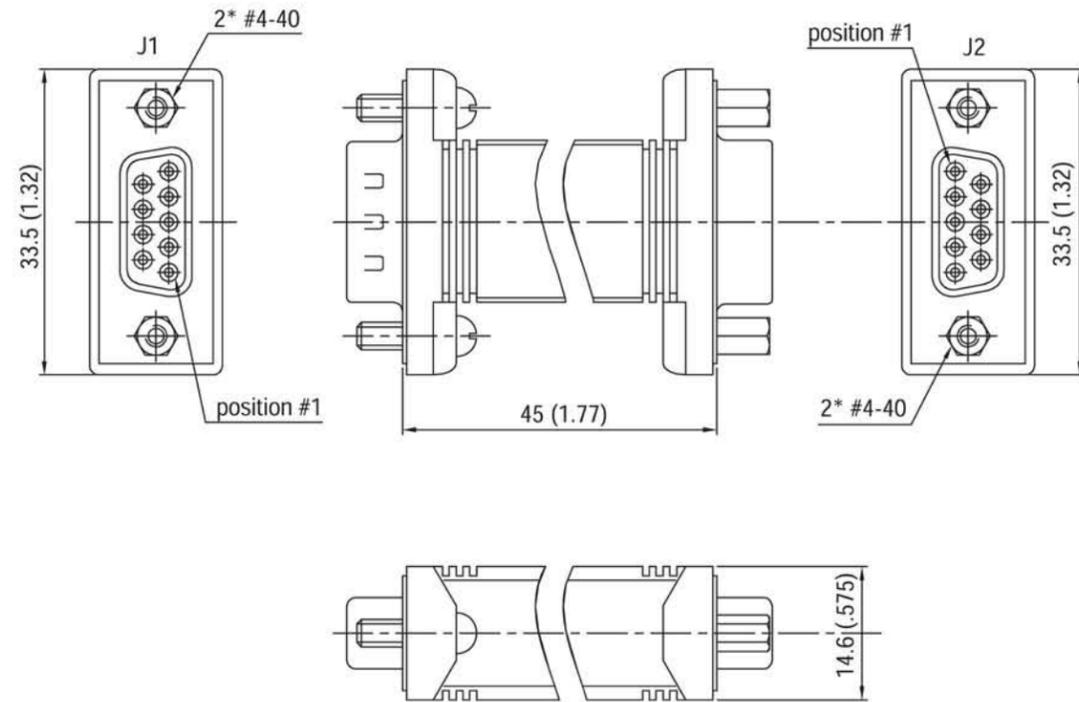

Wiring table

J1	2	3	4	5	6	7	8
J2	3	2	6	5	4	8	7

PAPT NUMBER	Description	Color
L G517 97001 L G517 97002 L G517 97015	D-Sub Male 9-pos. to D-sub Male 9-pos.	beige gray black
L G517 97016 L G517 97017 L G517 97018	D-Sub Female 9-pos. to D-sub Female 9-pos.	beige gray black
L G517 97019 L G517 97020 L G517 97021	D-Sub Male 9-pos. to D-sub Female 9-pos.	beige gray black

25-position to 25-position

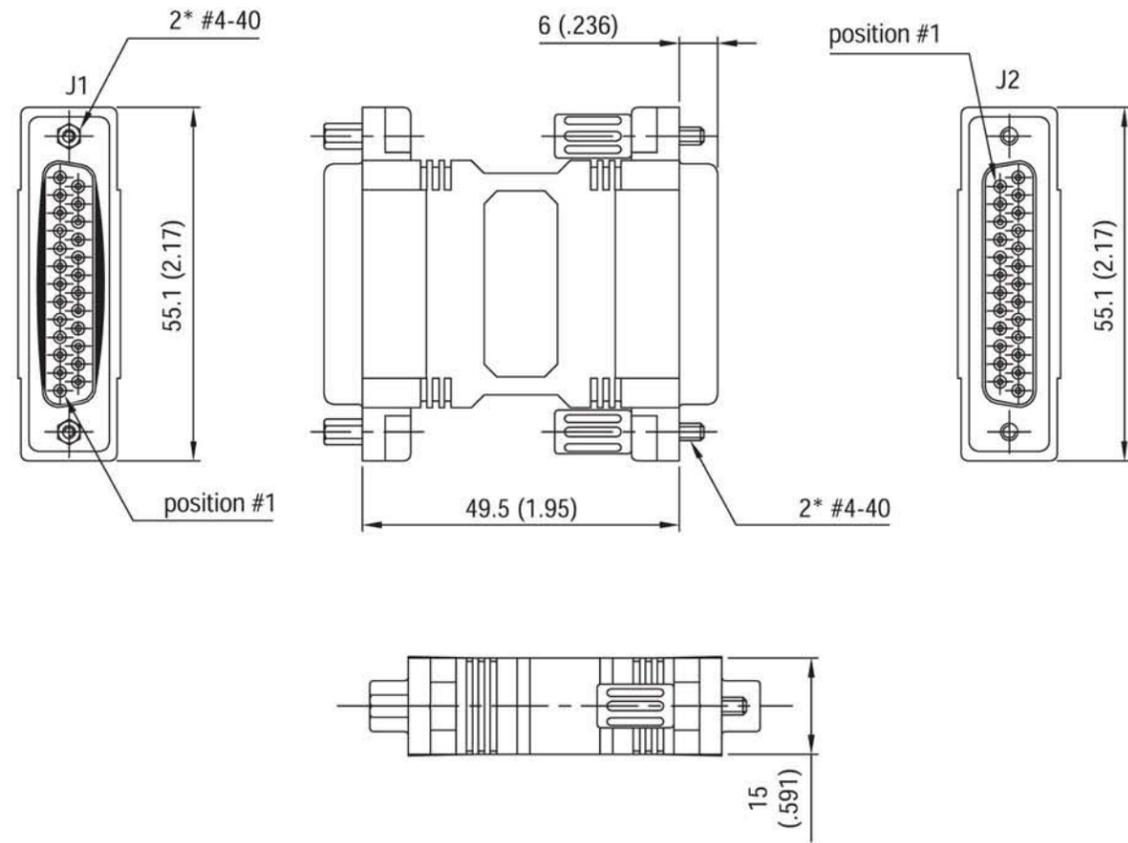

Wiring table

J1	1	2	3	4	...	24	25
J2	1	2	3	4	...	24	25

PAPT NUMBER	Description	Color
L G517 97022 L G517 97023 L G517 97024	D-Sub Male 25-pos. to D-sub Male 25-pos.	beige gray black
L G517 97025 L G517 97026 L G517 97027	D-Sub Female 25-pos. to D-sub Female 25-pos.	beige gray black
L G517 97028 L G517 97029 L G517 97030	D-Sub Male 25-pos. to D-sub Female 25-pos.	beige gray black



## IDC DISCRETE WIRE CONNECTORS

CHARACTERISTICS

Materials and Platings	
<b>Shells</b>	Steel, tin over nickel
<b>Contacts</b>	Phosphor bronze
<b>Plating</b>	Contact area: gold over nickel IDC area: tin over nickel
<b>Wire types</b>	Solid and stranded wires AWG 24-28

Electrical Data	
<b>Current rating</b>	5A
<b>Voltage rating</b>	500V AC at sea level
<b>Dielectric</b>	Thermoplastic Polyesther UL 94 VO rated

Climatic Data	
<b>Operating temperature</b>	-55°C to +125°C
<b>Salt spray</b>	24 hours

Mechanical Data	
<b>Mating and unmating force</b>	Size E 30 N Max. 3.5 N Mini. Size A 50 N Max. 4.5 N Mini. Size B 83 N Max. 8.0 N Mini. Size C 123 N Max. 11.0 N Mini.
<b>Standard plating thickness</b>	Gold flash 0.4µm (15µ") Gold 0.76 µm (30µ") Gold

DESCRIPTION

Amphenol IDC discrete D-sub connectors offer a low-profile design that accommodates many of the compact requirements of computer interfacing, instrumentation and, business equipment. Fast, four-point solderless termination ensures reliable connections. This series is available in 9, 15, 25, & 37 contact configurations. Contacts, including stain relief, are easily removable in case of repair.

*Simplify  
your cable  
assemblies*

APPLICATIONS

- Industrial
- Telecom
- Any industry standard I/O connections

IDC / E25



**Amphenol**

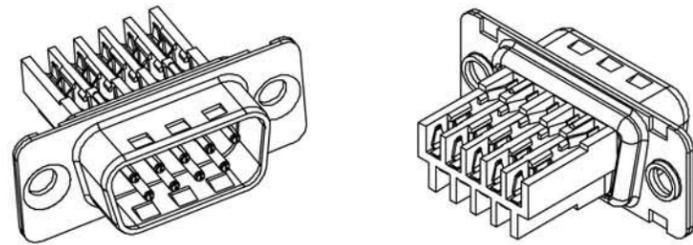
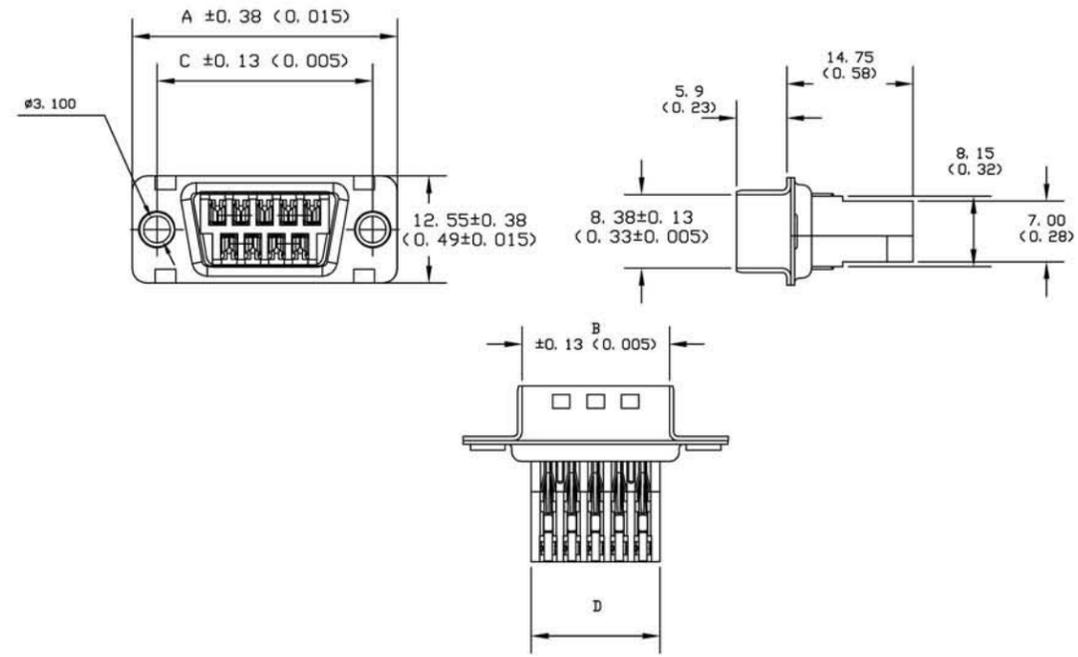

Nb OF CONTACTS	DIMENSIONS mm (inch)			
	A	B	C	D
9	30.81 (1.21)	16.92 (0.67)	24.99 (0.98)	14.90 (0.59)
15	39.14 (1.54)	25.25 (0.99)	33.32 (1.31)	23.00 (0.91)
25	53.04 (2.09)	38.96 (1.53)	47.04 (1.85)	36.90 (1.45)
37	69.32 (2.73)	55.42 (2.18)	63.50 (2.50)	59.30 (2.33)

OVERALL DIMENSION

IDC / E25



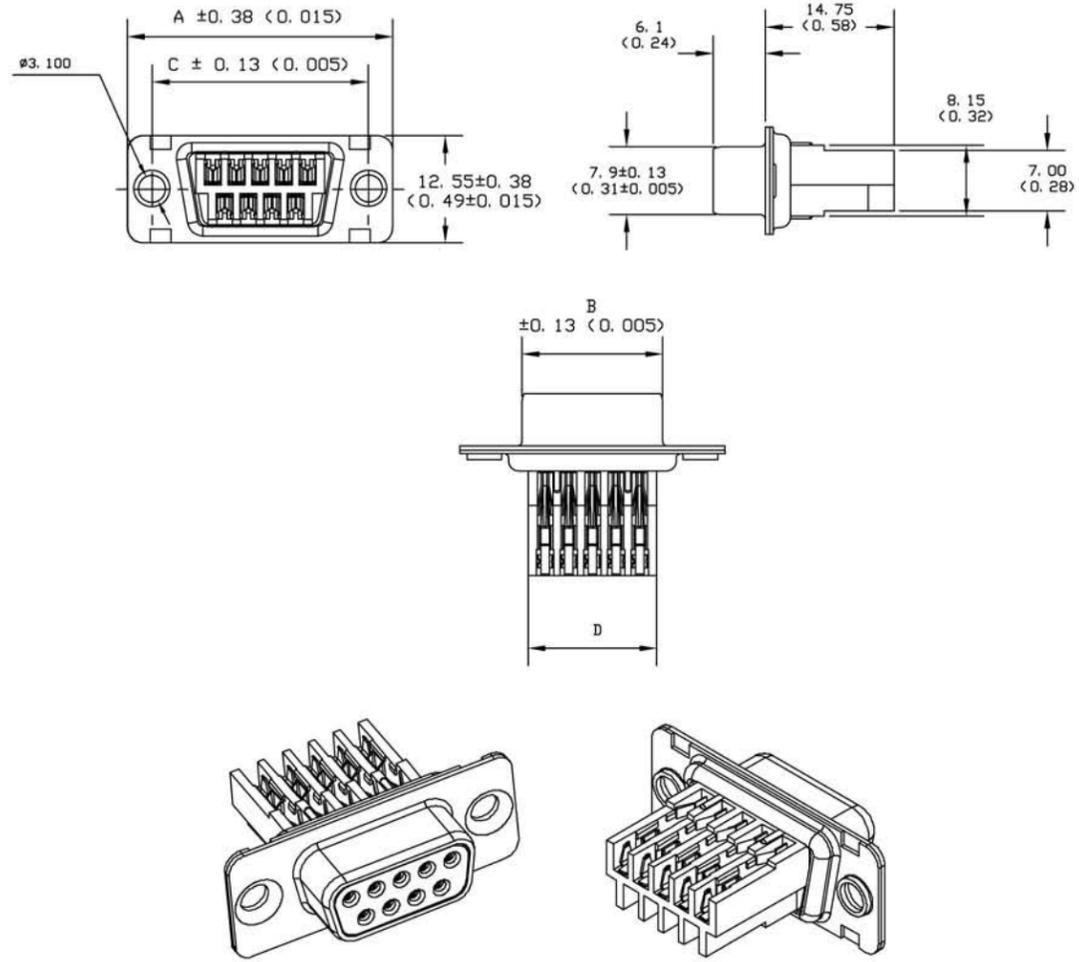

Nb OF CONTACTS	DIMENSIONS mm (inch)			
	A	B	C	D
9	30.81 (1.21)	16.24 (0.64)	24.99 (0.98)	14.90 (0.59)
15	39.14 (1.54)	24.56 (0.97)	33.32 (1.31)	23.00 (0.91)
25	53.04 (2.09)	38.38 (1.51)	47.04 (1.85)	36.90 (1.45)
37	69.32 (2.73)	54.76 (2.16)	63.50 (2.50)	59.30 (2.33)



<b>Terminating frame</b> Ref: 21046		
<b>Terminating head</b> Ref: 976 MC		
<b>Connector holders references</b>		
Number of Contacts	Plug	Socket
09	991 MC	992 MC
15	993 MC	994 MC
25	995 MC	996 MC
37	997 MC	998 MC
<b>Hand tool</b> Ref: 989 MC Single insertion tool		

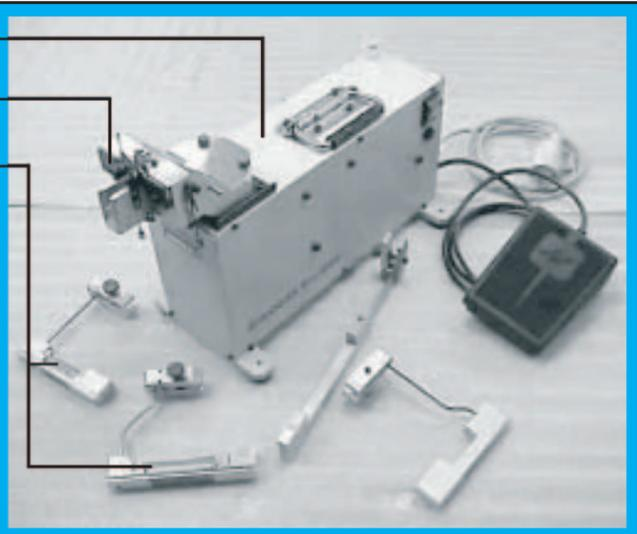

How to order

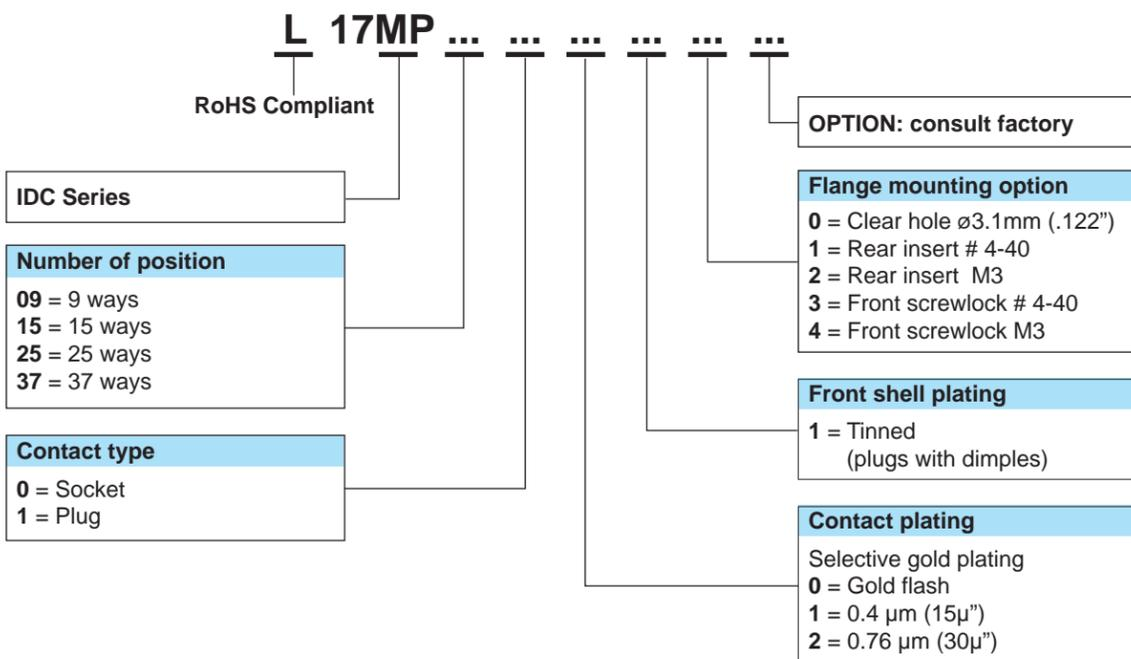

Do not hesitate to contact us for further information

# Amphenol

## Amphenol IT & Communication Products

Block A3/A4, The 4th Industrial District of  
 Industrial Headquarters, Dong Keng Road  
 Gong Ming Town, Shen Zhen China  
 Fax: +86(0)755 2754 9955

**Technical Support**

Tel: +86(0)755 2717 7945  
 Info-dsub@amphenol.com.cn  
 http://www.dsubconnector.com

# SD308



For Sea, Air or Land, these connectors are SEALED! Amphenol's SD308 Sealed D-Subminiature Connectors are available in the full range of standard density and hi-density insert arrangements, pin and socket contacts. These connectors are supplied with fixed screw machine contacts and are available in Solder Cup, Straight PCB, and Right Angle PCB terminations.

- Ruggedized Computers and Peripheral Equipment
- Industrial Controllers
- 21st Century Soldier
- Ideal For Retrofit Applications Or Late Design-In

## Sealed D-Sub Connectors

### SPECIFICATIONS:

#### PRODUCT FEATURES

- One piece machined Aluminum Shell
- Gold Plated Screw Machine Contacts
- Hi Grade Thermoplastic Inserts -67°F to +257°F (-55°C to +125°C)
- Integrated Blind Panel Mounts
- Supplied with Conductive Panel Seal Gasket

#### MATERIALS AND PLATINGS

**Shells** Machined aluminum alloy, tin plated  
**Inserts** High temperature resistant polyethersulfone per mil-p-46185  
**Contacts** Copper alloy, 20µ" (0.51µm) gold plated over nickel.  
**Seal** Silicone elastomer with nickel plated graphite flake

#### ELECTRICAL DATA

**Current Rating** 5A  
**Insulation Resistance** 5 GIGOHM @ 500 VDC  
**Working Voltage** 120 VAC  
**D.W.V.** 1,000 VAC pin to pin & pin to shell

#### CLIMATIC DATA

**Operating Temperature** -67°F to +257°F (-55°C to +125°C)

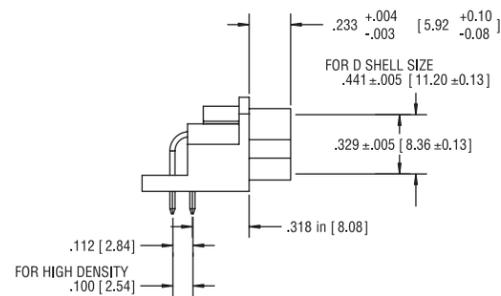

PLUG - SIDE VIEW

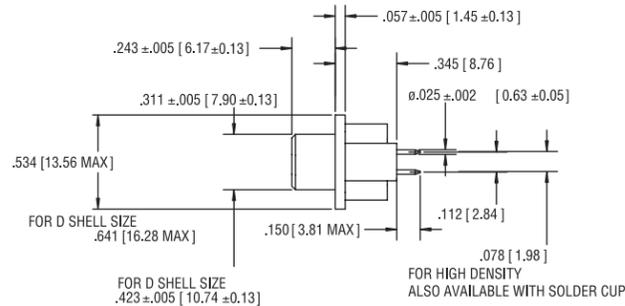

RECEPTACLE - SIDE VIEW

### SD308 - E09 - S - A - 1 - 000

Series Designation

Shell Size & Number Of Contacts

STD Density E09, A15, B25, C37, D50  
 HIGH Density E15, A26, B44, C62, D78, 6106

Contact Type

S=Socket Contact P= Pin Contact

000 = Standard part  
 other deviations as required

Mounting Type

1 = 4-40 Blind Nut  
 2 = 4-40 Blind Nut with R/A Mounting Bracket

Termination Style

A = Right Angle pcb B = Vertical pcb  
 C = Solder Cup

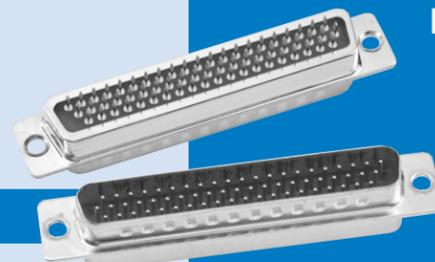

**SPECIFICATIONS:**

**DESCRIPTION**

- Hi reliability filtering in multi row arrangements
- Stamped and Formed shells
- Screw Machine Contacts and Hi Reliability inserts
- Available in all Hi-Density insert patterns

**MATERIALS AND PLATINGS**

**Shells** Stamped steel shell, tin plated  
**Inserts** High temperature resistant polyethersulfone per MIL-P-46185  
**Contacts** Machined copper alloy, 20µ" (0.51µm) gold plated over nickel  
**Capacitor** Barium titanate ceramic array

**ELECTRICAL DATA**

**Current Rating** 5 A  
**Insulation Resistance** 5 GIGOHM @ 500 VDC  
**Working Voltage** 200 VDC  
**D.W.V.** 500 VDC pin to pin & pin to shell  
**Capacitance** +/- 20% ( see P/N description )

**CLIMATIC DATA**

**Operating Temperature** -67°F to +257°F (-55°C to +125°C)

For 50 position and all high density versions. Amphenol's FD308 Filtered D-Subminiature connectors are available in the full range of hi-density insert arrangements, pin and socket contacts, plus the 50 position standard density. These connectors are supplied with fixed screw machine contacts and are available in Straight and Right Angle PCB terminations and Solder Cup.

- Computers and Peripheral Equipment
- Avionics Systems Ideal For Retrofit Applications Or Late Design-In

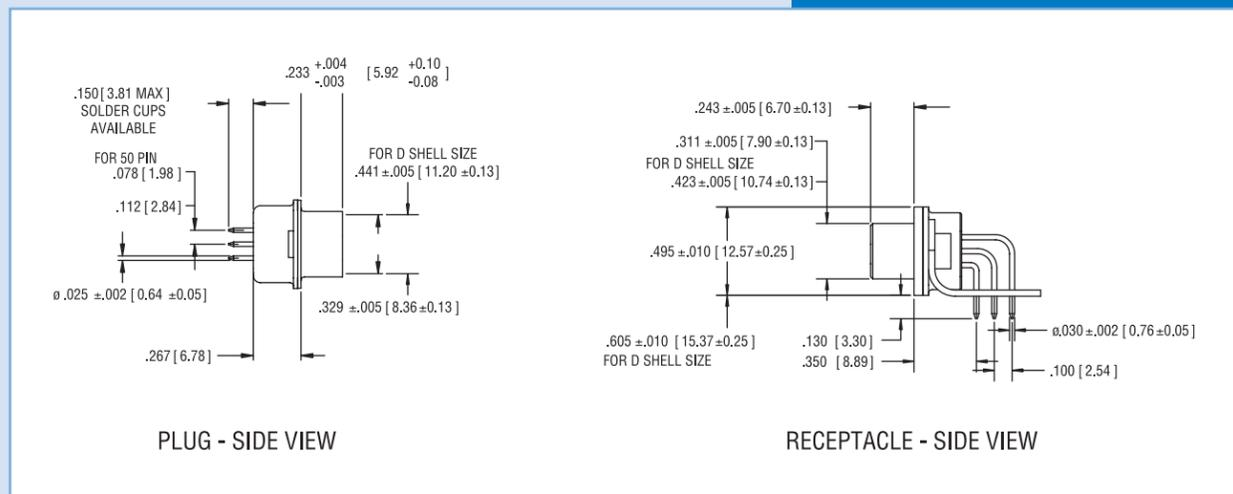

**FD308 - B44 - S - A - 1 - A2 - 000**

<p><b>Series Designation</b> —————</p> <p><b>Size &amp; Number Of Contacts</b> —————                  STD Density E09, A15, B25, C37, D50                  High Density E15, A26, B44, C62, D78, 6104</p> <p><b>Contact Type</b> —————                  S = Socket Contact P = Pin Contact</p> <p><b>Termination Style</b> —————                  A = Right Angle pcb                  B = Vertical pcb                  C = Solder Cup</p>	<p><b>000</b> = Standard part                  other deviations as required</p> <p><b>Capacitance Code</b>                  A2 = 200 PF    02 = 2000 PF                  A4 = 400 PF    05 = 5000 PF                  01 = 1000 PF</p> <p><b>Mounting Type</b>                  1 = 4-40 Clinch Nut                  2 = Ø.120 (3.05) Hole                  3 = R/A Mounting Bracket                  4 = 4-40 Clinch Nut                      with R/A Mounting Bracket</p>
---	--

**ORDERING INFORMATION - IDC**

**FCC17 - E09 - S - W - 4 - 8 - 0 - G**

<p><b>Series Designation</b></p> <p><b>Size and Configuration</b> 15 &amp; 25 Size Consult Factory.</p> <p><b>Connector Type</b> S: Socket P: Pin Consult Factory.</p> <p><b>Termination Type</b> W: IDC *</p> <p><b>Mounting</b> 2: .120 (3.05) Diameter Through Hole 4: 4-40 Threaded Inserts 6: M3 Threaded Inserts</p>	<p><b>Special</b> G: 50 Micro Inches Gold</p> <p><b>Modifier</b> 0: Standard Product x: Special or Custom Versions</p> <p><b>Capacitance Value</b> D: 50 pF    5: 1,000 pF 0: 180 pF    E: 2,200 pF F: 330 pF    9: 5,600 pF 1: 470 pF    8: 47,000 pF 4: 820 pF</p> <p>Other Capacitance values available. Consult Factory.</p>
--	--

**ORDERING INFORMATION - FILTERED PRESS FIT**

**FCC17 - B25 - S - R - 4 - 8 - 0 - G**

<p><b>Series Designation</b></p> <p><b>Size and Configuration *</b></p> <p><b>Connector Type</b> S: Socket P: Pin Consult Factory.</p> <p><b>Termination Type</b> R: Press Fit</p> <p><b>Mounting</b> 2: .120 (3.05) Diameter Through Hole 3: 4-40 Self Locking Threaded Insert 4: 4-40 Threaded Inserts 5: 4-40 Threaded Standoff 6: M3 Threaded Inserts E: Code 4 with 4-40 Hex Jack Socket</p>	<p><b>Special</b> G: 50 Micro Inches Gold</p> <p><b>Modifier</b> 0: Standard Product x: Special or Custom Versions</p> <p><b>Capacitance Value</b> D: 50 pF    5: 1,000 pF 0: 180 pF    E: 2,200 pF F: 330 pF    9: 5,600 pF 1: 470 pF    8: 47,000 pF 4: 820 pF</p> <p>Other Capacitance values available. Consult Factory.</p>
---	--

**ORDERING INFORMATION - STACKED D-SUB**

**FCC17 - 2 - BP - BS - 4 - 5 - 5 - X**

<p><b>Series Designation</b></p> <p><b>Vertical Mounting Dimension Between Connectors</b> 1 = .625 (15.88) 2 = .750 (19.05)</p> <p><b>Upper Connector Configuration (Size and Style)</b> EP: 9 pin    BP: 25 pin ES: 9 socket    BS: 25 socket AP: 15 pin    CP: 37 pin AS: 15 socket    CS: 37 socket</p> <p><b>Lower Connector Configuration</b> (Size and Style) same as Upper Connector Configuration</p> <p><b>Mounting</b> 2: .120 (3.05) Diameter Through Hole on Flanges 4: 4-40 Threaded Inserts on Flanges E: 4-40 Hex Jack Sockets (supplied loose)</p>	<p><b>Modifier</b> 0: Standard Product x: Special or Custom Versions</p> <p><b>Lower Connector Filter Capacitance</b> same as Upper Connector Filter Capacitance Designation</p> <p><b>Upper Connector Filter Capacitance</b> D: 50 pF    5: 1,000 pF 0: 180 pF    E: 2,200 pF F: 330 pF    7: 1,200 pf 1: 470 pF    9: 5,600 pF 4: 820 pF    8: 47,000 pF</p> <p>* For Additional Mounting Options and Filter Capacitance - Consult Factory</p>
--	--

### ORDERING INFORMATION - D-SUB

FCC17 - B25 - S - C - 4 - 4 - 0 - G

**Series Designation** \_\_\_\_\_

**Size** \_\_\_\_\_  
E09, A15, B25, C37

**Connector type** \_\_\_\_\_  
A - Adapter P - Pin S - Socket

**Termination Type** \_\_\_\_\_  
A - Right Angle PC Tail, .318 (8.08) Footprint    E - Vertical Mount PC Tail  
B - Right Angle PC Tail, .405 (10.29) Footprint    M - Solder Cup  
C - Right Angle PC Tail, .590 (14.99) Footprint    N - Vertical Mount PC Tail - Long Body  
D - Pin/Socket Adapter

**Mounting options\***

A: 4-40 Threaded PC Tail Standoffs with Boardlock, Vertical Mount Only	3: Self-Locking 4-40 Threaded Inserts
E: 4-40 Hex Jack Sockets (supplied loose)	4: 4-40 Threaded Inserts (Standard)
F: 4-40 Round Fixed Jack Sockets	5: 4-40 Threaded Stand-Offs, Vertical Mount
2: .120 (3.05) diameter Through hole	6: M3 Threaded inserts

**Specials**  
No Digit: Standard 15µ\* (0.38µm) gold  
G: 50µ\* (1.27µm) gold  
K: 30µ\* (0.76µm) gold  
L: Standard Connector with added ferrite block

**Modifier**  
0 = Standard Product (Boardlocks on Right Angle D-Subs)  
B = Metal Mounting Brackets, for Right Angle D-Subs  
D = .315 (8.00) to Boardlock for .590 (14.99) footprint  
E = Plastic Bracket - No Boardlock  
F = No Boardlock, No plastic or metal Bracket - Alignment Strip Only  
X = Specials or Custom Versions

**Filter Capacitance (pF)\***

D: 50 pF	5: 1,000 pF
B: 100 pF	7: 1,200 pF
0: 180 pF	E: 2,200 pF
F: 330 pF	9: 5,600 pF
1: 470 pF	8: 47,000 pF
4: 820 pF	

\* For Additional Mounting Options and Filter Capacitance - Consult Factory

### ORDERING INFORMATION - COMBO D-SUB

FCC17 - A - 3W3 - P - M - 4 - 5 - 0 - G

**Series Designation** \_\_\_\_\_

**Shell Size** \_\_\_\_\_  
A, B, C, D, E

**Arrangement** \_\_\_\_\_

**Connector type** \_\_\_\_\_  
A = Adapter, P = Pin, S = Socket

**Termination type** \_\_\_\_\_  
D = Pin/Socket Adapter  
E = Power PC Tail - 40A - .126 (3.20) Dia., .175 (4.44) Lg.  
K = Power Solder Cup - 10A - Wire Size 16  
L = Power Solder Cup - 20A - Wire Size 12  
M = Power Solder Cup - 40A - Wire Size 8  
R = Power Press Fit - 20A - .145 (3.68) Lg. - .126 (3.20) Dia. Hole

**Mounting Options**

2 = .120 (3.05) dia. mounting holes	5 = 4-40 Standoffs - PC tail only
3 = 4-40 Threads Self locking	6 = M3 Threads
4 = 4-40 Threads	E = 4-40 Hex Jack Sockets (supplied loose)

**Plating Option**  
Blank = Standard 30µ\* (0.76µm) gold  
G = 50µ\* (1.27µm) gold

**Modifier**  
0 = Standard  
X = Specials or Custom versions (Consult Factory)

**Filter Capacitance (pF)**

D: 50 pF	5: 1000 pF
B: 100 pF	7: 1200 pF
o: 180 pF	E: 2200 pF
f: 330 pF	9: 5600 pF
l: 470 pF	8: 47000 pF
4: 820 pF	

\* For Additional Mounting Options and Filter Capacitance - Consult Factory

# D'Sub Metallic Hoods

DTZK & DVZK series



MAIN CHARACTERISTICS

- **Material and plating:**  
Zinc die-cast, nickel plated
- **Cable strainrelief:**  
Steel fiber reinforced Polycarbonate UL94V-O
- **Temperature range:**  
-40°C to 120°C
- **Cable diameter:**  
3 to 13mm
- **Attenuation factor:**  
> 40 dB between 30 MHz and 1 GHz
- **Approvals:**  
VDE 0871 - FCC 20780 - 89 / 336 / EU

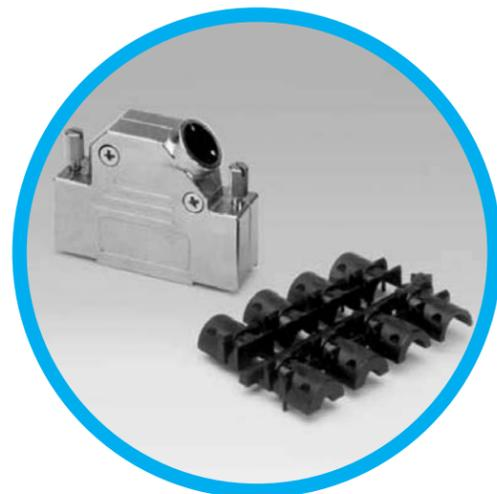

DESCRIPTION

Amphenol metallic hood series for D'Sub connectors offers protection from magnetic and radio interference to cable assemblies.

Easily assembled these hoods are suitable for all industrial and telecom applications.

*Shield  
Your cable  
assemblies!*

APPLICATIONS

- Industrial
- Military
- Telecom
- Any application requiring EMI/RFI protection

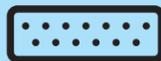

Amphenol

D'SUB ACCESSORIES / E23

DTZK Series

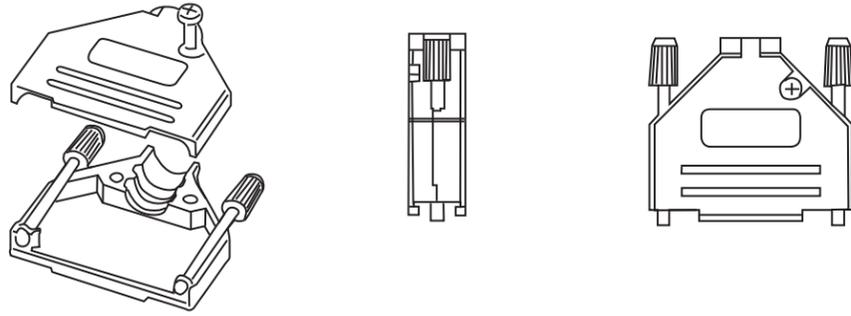

Part number	A	B
L17DTZK9Kxx	21 (.827")	38.3 (1.508")
L17DTZK15Kxx	39.5 (1.555")	40.5 (1.594")
L17DTZK25Kxx	54.4 (2.144")	47.3 (1.862")
L17DTZK37Kxx	70.9 (2.791")	52.2 (2.055")

DVZK Series

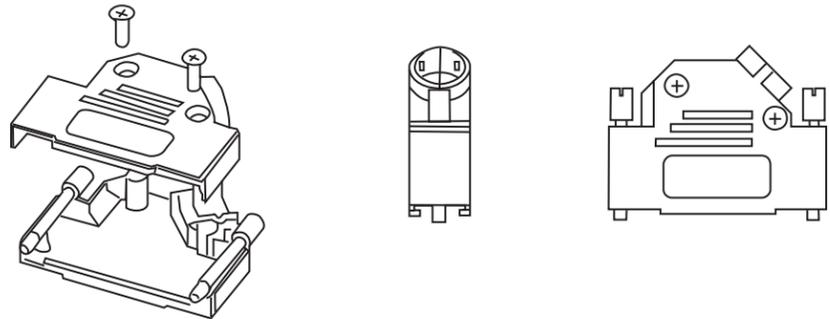

Part number	A	B
L17DVZK9Kxx	31 (1.220")	36,2 (1.425")
L17DVZK15Kxx	39,5 (1.555")	40,2 (1.583")
L17DVZK25Kxx	53,2 (2.094")	40,2 (1.583")
L17DVZK37Kxx	69,7 (2.744")	40,2 (1.583")

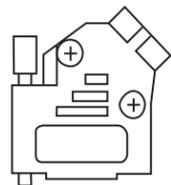

Type	A
L17DTZK9Kxx	30
L17DTZK15Kxx	(1.181")
L17DTZK25Kxx	40
L17DTZK37Kxx	(1.575")

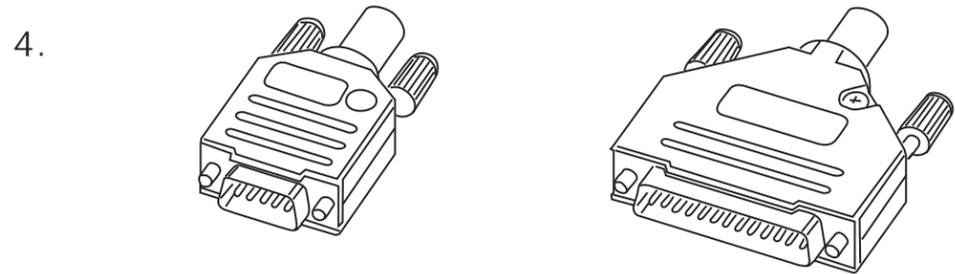
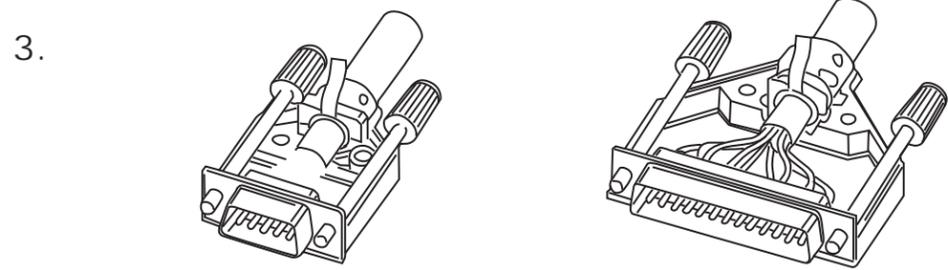
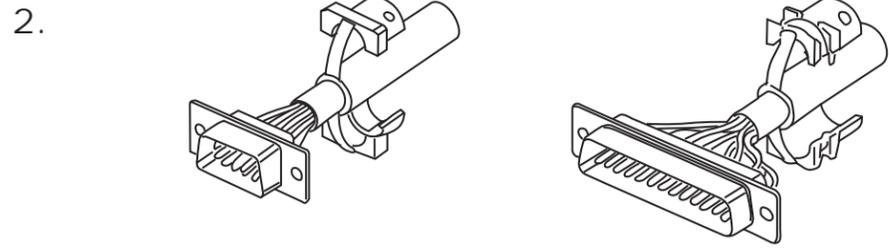
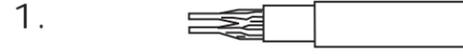



Assembly Instructions DVZK Series

1.

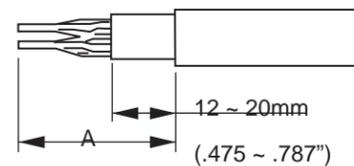

2.

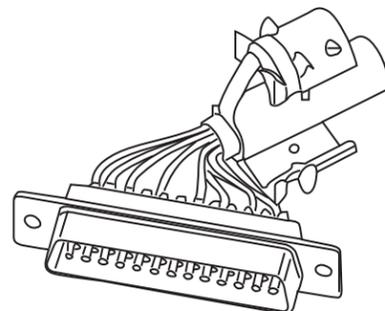

3.

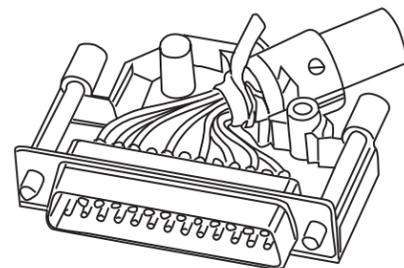

4.

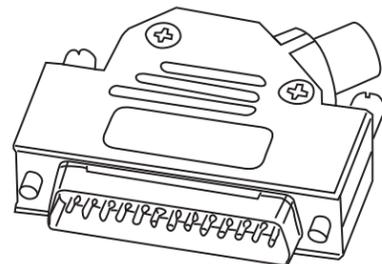

Type	A
L17DVZK9Kxx	30
L17DVZK15Kxx	(1.181")
L17DVZK25Kxx	45
L17DVZK37Kxx	(1.772")

Do not hesitate to contact us for further information



**Amphenol**

**Amphenol IT & Communication Products**

Block A3/A4, The 4th Industrial District of  
Industrial Headquarters, Dong Keng Road  
Gong Ming Town, Shen Zhen China  
Fax: +86(0)755 2754 9955

**Technical Support**

Tel: +86(0)755 2717 7945  
Info-dsub@amphenol.com.cn  
http://www.dsubconnector.com

## ACCESSORIES



Amphenol's black plastic backshell accommodates most standard and high-density D-Subminiature connectors and is appropriate for most cable assemblies. This version is economical and highly durable. The split-grommet insert provides cable strain relief while making it easy to assemble.

## Plastic Backshell

### SPECIFICATIONS:

**Housing Material:** Styrene (UL 94 VO)  
**Grommet Material:** Polypropylene  
**Mounting Hardware:** Steel, clear zinc finish \*RoHS Compliant

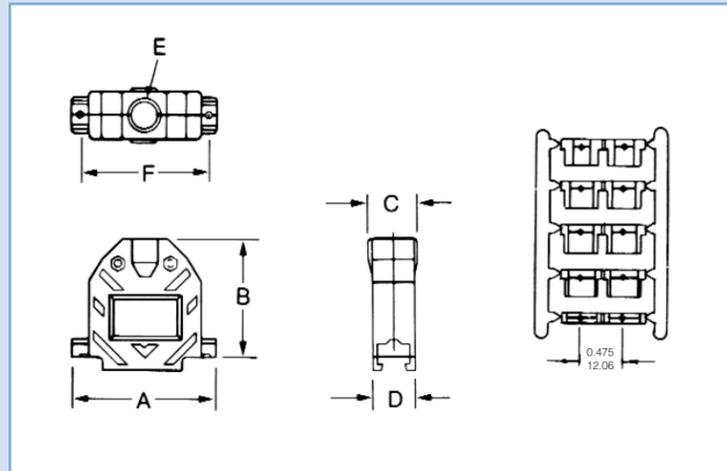

### DIMENSIONS AND ORDERING INFORMATION

Shell Size	Standard # of Contacts	Hi-Density # of Contacts	Part #	Dimensions						Cable Diameter Range	
				A	B	C	D	E	F	Minimum	Maximum
E	9	15	17E-1724-1	1.217 (30.91)	1.547 (39.29)	0.640 (16.26)	0.640 (16.26)	0.400 (10.16)	0.984 (24.99)	0.210 (5.33)	0.350 (8.89)
A	15	26	17E-1725-1	1.545 (39.24)	1.505 (38.23)	0.640 (16.26)	0.640 (16.26)	0.400 (10.16)	1.312 (33.32)	0.210 (5.33)	0.350 (8.89)
B	25	44	17E-1726-1	2.090 (53.08)	1.655 (42.04)	0.710 (18.03)	0.640 (16.26)	0.522 (13.26)	1.857 (47.17)	0.230 (5.84)	0.450 (11.43)
C	37	62	17E-1727-1	2.734 (69.44)	1.830 (46.48)	0.906 (23.01)	0.640 (16.26)	0.726 (18.44)	2.500 (63.50)	0.350 (8.89)	0.640 (16.26)
D	50	78	17E-1728-1	2.645 (67.18)	1.855 (47.12)	0.940 (23.88)	0.770 (19.56)	0.726 (18.44)	2.406 (61.11)	0.350 (8.89)	0.640 (16.26)

AMPHENOL D-SUBMINIATURE

**Plated Plastic Backshell**

**SPECIFICATIONS:**

**Housing Material:** ABS Polymer  
**Plating:** Nickel over copper  
**Grommet Material:** PVC (UL 94 VO)  
**Mounting Hardware:** Steel, clear zinc finish \*RoHS Compliant

**ASSEMBLY INSTRUCTIONS**

1. Select the tightest insert that will fit over the cable and thread the cable through it, placing the end with the smaller O.D. (the end without the washer) towards the connector.
2. Cut the jacket, fold the shielding back over the outside of the insert and cut it just short of the washer.
3. Install jackscrews and connector.
4. Place the washer in the outermost depression in the exit area of the hood and screw the cover closed.

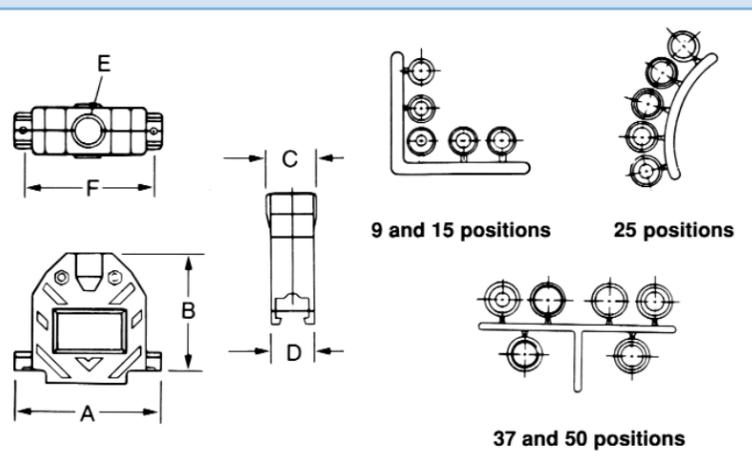

**ACCESSORIES**

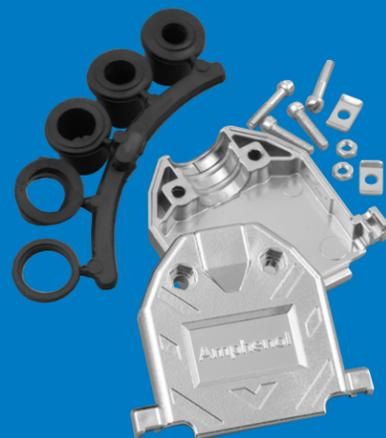

Amphenol's plated plastic backshell accommodates most standard and high-density D-Subminiature connectors and is appropriate for cable assemblies requiring compliance to FCC 20780. This version is highly durable and provides EMI/RFI protection. The rubber grommet compression insert forces the cable's shielding against the inside of the cable exit area, assuring shielding.

**DIMENSIONS AND ORDERING INFORMATION**

Shell Size	Standard # of Contacts	Hi-Density # of Contacts	Part #	Dimensions						Cable Diameter Range	
				A	B	C	D	E	F	Minimum	Maximum
E	9	15	17E-1724-2	1.217 (30.91)	1.547 (39.29)	0.640 (16.26)	0.640 (16.26)	0.400 (10.16)	0.984 (24.99)	0.210 (5.33)	0.320 (8.13)
A	15	26	17E-1725-2	1.545 (39.24)	1.505 (38.23)	0.640 (16.26)	0.640 (16.26)	0.400 (10.16)	1.312 (33.32)	0.210 (5.33)	0.320 (8.13)
B	25	44	17E-1726-2	2.000 (50.8)	1.655 (42.04)	0.710 (18.03)	0.640 (16.26)	0.522 (13.26)	1.857 (47.17)	0.230 (5.84)	0.450 (11.43)
C	37	62	17E-1727-2	2.730 (69.34)	1.830 (46.48)	0.906 (23.01)	0.640 (16.26)	0.726 (18.44)	2.500 (63.50)	0.350 (8.89)	0.650 (16.51)
D	50	78	17E-1728-2	2.645 (67.18)	1.855 (47.12)	0.940 (23.88)	0.440 (11.18)	0.726 (18.44)	2.406 (61.11)	0.350 (8.89)	0.650 (16.51)

INCHES (MM)

## ACCESSORIES

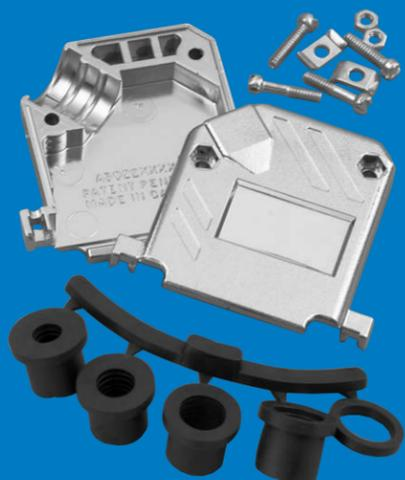

Amphenol's plated plastic backshell accommodates most standard and high-density D-Subminiature connectors and is appropriate for cable assemblies requiring compliance to FCC 20780. This version is highly durable and provides EMI/RFI protection. The rubber grommet compression insert forces the cable's shielding against the inside of the cable exit area, assuring shielding. The 45° cable exit helps save space behind equipment.

## 45° Plated Plastic Backshell

### SPECIFICATIONS:

**Housing Material:** ABS Polymer  
**Plating:** Nickel over copper  
**Grommet Material:** PVC (UL 94 VO)  
**Mounting Hardware:** Steel, clear zinc finish \*RoHS Compliant

### ASSEMBLY INSTRUCTIONS

1. Select the tightest insert that will fit over the cable and thread the cable through it, placing the end with the smaller O.D. (the end without the washer) towards the connector.
2. Cut the jacket, fold the shielding back over the outside of the insert and cut it just short of the washer.
3. Install jackscrews and connector.
4. Place the washer in the outermost depression in the exit area of the hood and screw the cover closed.

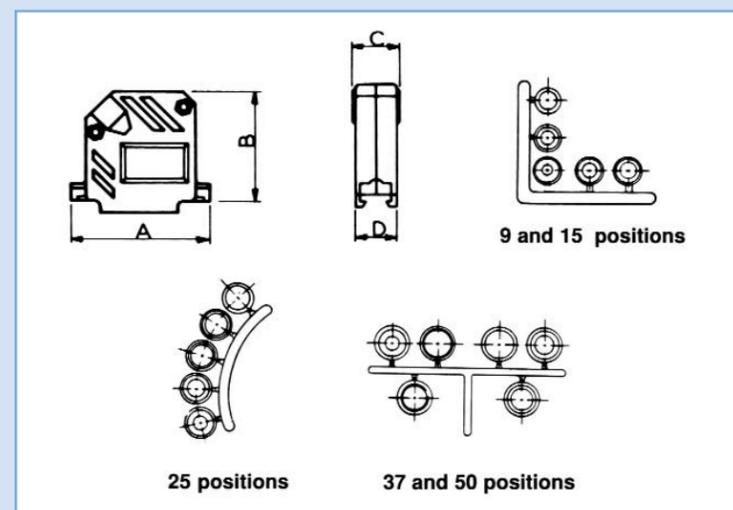

### DIMENSIONS AND ORDERING INFORMATION

Shell Size	Standard # of Contacts	Hi-Density # of Contacts	Part #	Dimensions						Cable Diameter Range	
				A	B	C	D	E	F	Minimum	Maximum
E	9	15	17E-1824-2	1.217 (30.91)	1.430 (36.32)	0.640 (16.26)	0.640 (16.26)	0.400 (10.16)	0.984 (24.99)	0.210 (5.33)	0.320 (8.13)
A	15	26	17E-1825-2	1.545 (39.24)	1.568 (39.83)	0.640 (16.26)	0.640 (16.26)	0.400 (10.16)	1.312 (33.32)	0.210 (5.33)	0.320 (8.13)
B	25	44	17E-1826-2	2.090 (53.09)	1.735 (44.07)	0.710 (18.03)	0.640 (16.26)	0.522 (13.26)	1.857 (47.17)	0.230 (5.84)	0.450 (11.43)
C	37	62	17E-1827-2	2.734 (69.44)	1.976 (50.19)	0.906 (23.01)	0.640 (16.26)	0.726 (18.44)	2.500 (63.5)	0.350 (8.89)	0.650 (16.51)

AMPHENOL D-SUBMINIATURE

## Two-Piece Die Cast Shielded Backshells

### SPECIFICATIONS:

Housing Material: Die cast zinc  
 Grommet Material: PVC (UL 94 VO)  
 Mounting Hardware: Steel, clear zinc finish \*RoHS Compliant

### ASSEMBLY INSTRUCTIONS

1. Select the tightest insert that will fit over the cable and thread the cable through it, placing the end with the smaller O.D. (the end without the washer) towards the connector.
2. Cut the jacket, fold the shielding back over the outside of the insert and cut it just short of the washer.
3. Install jackscrews and connector.
4. Place the washer in the outermost depression in the exit area of the hood and screw the cover closed.

#### 9 and 15 positions

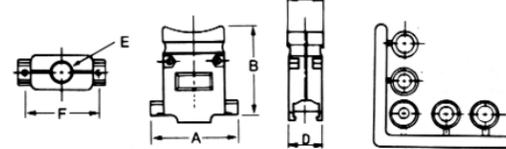

#### 25 positions

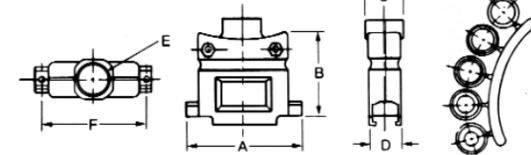

#### 37 and 50 positions

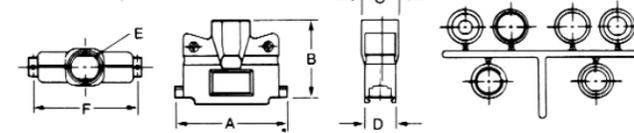

## ACCESSORIES



Amphenol's metal backshell accommodates most standard and high-density D-Subminiature connectors and is appropriate for cable assemblies requiring compliance to FCC 20780. This version is highly durable and provides EMI/RFI protection. The rubber grommet compression insert forces the cable's shielding against the inside of the cable exit area, assuring shielding.

### DIMENSIONS AND ORDERING INFORMATION

Shell Size	Standard # of Contacts	Hi-Density # of Contacts	Part #	Dimensions						Cable Diameter Range	
				A	B	C	D	E	F	Minimum	Maximum
E	9	15	17E-1657-09	1.217 (30.91)	1.430 (36.32)	0.640 (16.26)	0.640 (16.26)	0.400 (10.16)	0.984 (24.99)	0.210 (5.33)	0.320 (8.13)
A	15	26	17E-1657-15	1.545 (39.24)	1.568 (39.83)	0.640 (16.26)	0.640 (16.26)	0.400 (10.16)	1.312 (33.32)	0.210 (5.33)	0.320 (8.13)
B	25	44	17E-1657-25	2.090 (53.09)	1.735 (44.07)	0.710 (18.03)	0.640 (16.26)	0.522 (13.26)	1.857 (47.17)	0.230 (5.84)	0.450 (11.43)
C	37	62	17E-1657-37	2.734 (69.44)	1.976 (50.19)	0.906 (23.01)	0.640 (16.26)	0.726 (18.44)	2.500 (63.5)	0.350 (8.89)	0.640 (16.26)

INCHES (MM)

## X-ON Electronics

Largest Supplier of Electrical and Electronic Components

*Click to view similar products for [D-Sub Standard Connectors](#) category:*

*Click to view products by [Amphenol](#) manufacturer:*

Other Similar products are found below :

[DCM37S732N](#) [DAM15P500](#) [DEV09S364GTLF](#) [DEM09P032N](#) [DDM50P732N](#) [DAM15S332N](#) [173109-2218](#) [173109-2466](#) [173109-2436](#)  
[173109-2435](#) [56F706-005-LI](#) [56F711-015](#) [015-0341-000](#) [015-0372-008](#) [015-8544-011](#) [017041-0005](#) [020419-0104](#) [012-0515-000](#) [012-9507-](#)  
[034](#) [012-9507-114](#) [012-9534-001](#) [020745-0008](#) [609-25P](#) [M24308/2-23Z](#) [M243082310F](#) [M243082410F](#) [M243082411F](#) [M24308/4-21](#)  
[CT1A18-11PSA206](#) [CT1N36-5SC](#) [CT2-16S-17PS](#) [CT2-20-15PCAU](#) [CT2-24-12PS](#) [CT2-24-28PSF127A206](#) [CT2-32-9PC](#) [CT6F9767-14-4-](#)  
[14S-5PC](#) [CT6FA10SL-4PS](#) [CT7-18-10SC](#) [CT7-18-10SCAU](#) [CT7-18-12SCAU](#) [CT7-18-1PC](#) [CT7-18-1PCAU](#) [CT7-18-21SCAU](#) [M83513/01-](#)  
[FC](#) [M83723/76W24619 L/C](#) [M85049/48-3-2F](#) [69001-865](#) [6STD09PCM99B70X](#) [6STD09SCM99B30X](#) [6STD09SCT99S40X](#)