

NOTES:

1. MATERIALS AND FINISHES:
 BODY - BRASS, NICKEL PLATING (.000XXX THICK)
 CONTACT - BRASS, GOLD PLATING (.000XXX THICK)
 INSULATOR - PTFE
2. ELECTRICAL:
 A. IMPEDANCE: 500HM
 B. DIELECTRIC WITHSTANDING VOLTAGE: 3000 VRMS, MIN.
3. MECHANICAL:
 A. DURABILITY: 500 CYCLES MIN.
 B. TEMPERATURE RANGE: -65° C TO +165° C
4. PACKAGING:
 A. QUANTITY: SINGLE PACK
 B. MARKING: BAG TO BE MARKED
 "AMPHENOLRF, 82-61, AND DATE CODE"
5. ASTERISK (*) SHOWS CABLE ENTRY DIMENSIONS.

| | | | | | |
|-------------------|-----|-----------------------------|---------|-------|-------|
| 82-61 | | REVISIONS | | | |
| DRAWING NO. | REV | DESCRIPTION | DATE | ECO | APPR |
| THIRD ANGLE PROJ. | -- | RELEASE TO MFG | ----- | ----- | ----- |
| | AC | REDRAWN IN PRO-E, ADDED COD | 1/14/13 | 48616 | KR |

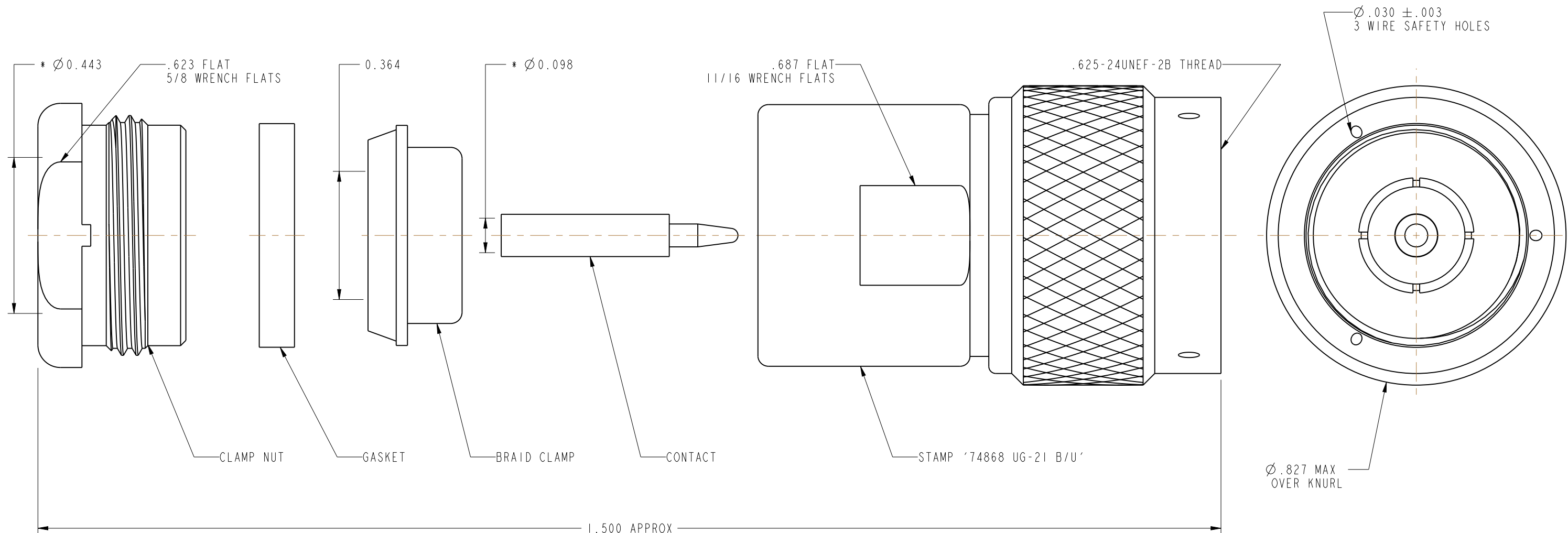

CUSTOMER OUTLINE DRAWING
 ALL OTHER SHEETS ARE FOR INTERNAL USE ONLY

| | | | | | |
|---------------------------------------------------------------------------------------------------------------------------------------------------------------------------------------------------------------------------------------------------------------------------------------------------------------------------------------------------------------------------------------------------------------------------------------------------------------------------------------------------------------------------------------------------------------------------------------------------------------------------------------------------------------------------------------------------------------------------------------|-----------|---------------------------------|-------------------|-------------------------------------|--------------------------------------------------------------------------------------------|
| UNLESS OTHERWISE SPECIFIED, DIMENSIONS ARE IN INCHES AND TOLERANCES ARE: 2 PLACE DECIMAL 3 PLACE DECIMAL ANGLES ±.015 (0,381 mm) ±.005 (0,127 mm) ± 1° | MATERIAL | DRAWN KARTHIK R | DATE 07-Jan-10 | TITLE PLUG TYPE 'N' UG-21 B/U | Amphenol RF Danbury, CT, USA Tainan, Taiwan Shenzhen, China www.amphenolrf.com |
| | REFERENCE | ENGINEER KARTHIK R | DATE 07-Jan-10 | | |
| NOTICE - These drawings, specifications, or other data (1) are, and remain the property of Amphenol Corp. (2) must be returned upon request; and (3) are confidential and not to be disclosed to any person other than those to whom they are given by Amphenol Corp. The furnishing of these drawings, specifications, or other data by Amphenol Corp., or to any other person to anyone for any purpose is not to be regarded by implication or otherwise in any manner licensing, granting rights or permitting such holder or any other person to manufacture, use or sell any product, process or design, patented or otherwise, that may in any way be related to or disclosed by said drawings, specifications, or other data. | | APPROVED K. CAPOZZI | DATE 1/14/13 | | SCALE: 3.5:1 SHEET 2 OF 2 |
| | | CAD FILE Root Folder/N/82-61 | CODE ID 74868 | DWG SIZE B | DRAWING NO. 82-61 |

X-ON Electronics

Largest Supplier of Electrical and Electronic Components

Click to view similar products for [RF Connectors / Coaxial Connectors](#) category:

Click to view products by [Amphenol](#) manufacturer:

Other Similar products are found below :

[8915-1511-000](#) [89674-0827](#) [6001-7071-019](#) [6002-7051-003](#) [6002-7551-202](#) [6059674-1](#) [619550-1](#) [630059-000](#) [M39030/3-01N](#) [M3933/25-36N](#) [6500-7071-046](#) [6769](#) [CX050L2AQ](#) [7002-1542-011](#) [7004-1512-000](#) [7009-1511-004](#) [7010-1511-000](#) [7029-1511-060](#) [7101-1541-010](#) [7101-1571-002](#) [7105-1521-002](#) [7145-1521-002](#) [7203-1571-003](#) [7209-1511-011](#) [7210-1511-015](#) [7210-1511-019](#) [73137-5015](#) [73216-2241](#) [7325-1512-000](#) [73404-2300](#) [7405-1521-005](#) [7405-1521-802](#) [7406-1521-005](#) [8527](#) [8547](#) [FS11V](#) [8808-1511-001](#) [9049-9513-000](#) [9074-9513-000](#) [9101-9573-002](#) [910A205F](#) [9130-9573-002](#) [PL11SC-026](#) [PL375-33](#) [PL40-5](#) [PL71-9](#) [PL74C-221](#) [PL75MC-217](#) [PL803-7](#) [980-8666-005](#)