

NOTES:

- MARKING IN "AREA 1 & 2" SHALL BE IN THE MOLD IN .045 MIN HIGH CHARACTERS. MARKING SHALL BE LOCATED CENTRALLY ON EDGE OF FLANGE AS SHOWN. CHARACTERS TO BE FLUSH WITH SURFACE MATERIAL, BACKGROUND TO BE .010 BELOW SURFACE (SEE TABLE).
- UNLESS OTHERWISE SPECIFIED:
 - HOLES, SLOTS AND DIAMETERS TO BE PARALLEL AND CONCENTRIC WITHIN .003 T.I.R.
 - REMOVE ALL BURS, BREAK ALL SHARP EDGES .005 MAX.
 - SURFACE FINISH TO BE 63 MICROINCHES MAX.
 - ALL DIMENSIONS ARE BEFORE PLATING.
- PART NUMBER CONTAINING LETTER SUFFIX REQUIRES PLATING PER AMPHENOL SPEC 349-50560.

83-363-X		REVISIONS			
DRAWING NO.	REV	DESCRIPTION	DATE	ECO	APPR
THIRD ANGLE PROJ.	⊕	RELEASE TO MFG.	8/10/53	1783	
	AT	REDRAWN TO PRO-E; ADD FLATS	11/14/01	43883	CPM
	AU	SHEET 2 ADDED	3/13/12	49007	AAP
	AV	COD SHEET NOTE REVISIONS.	3/20/15	50386	JN

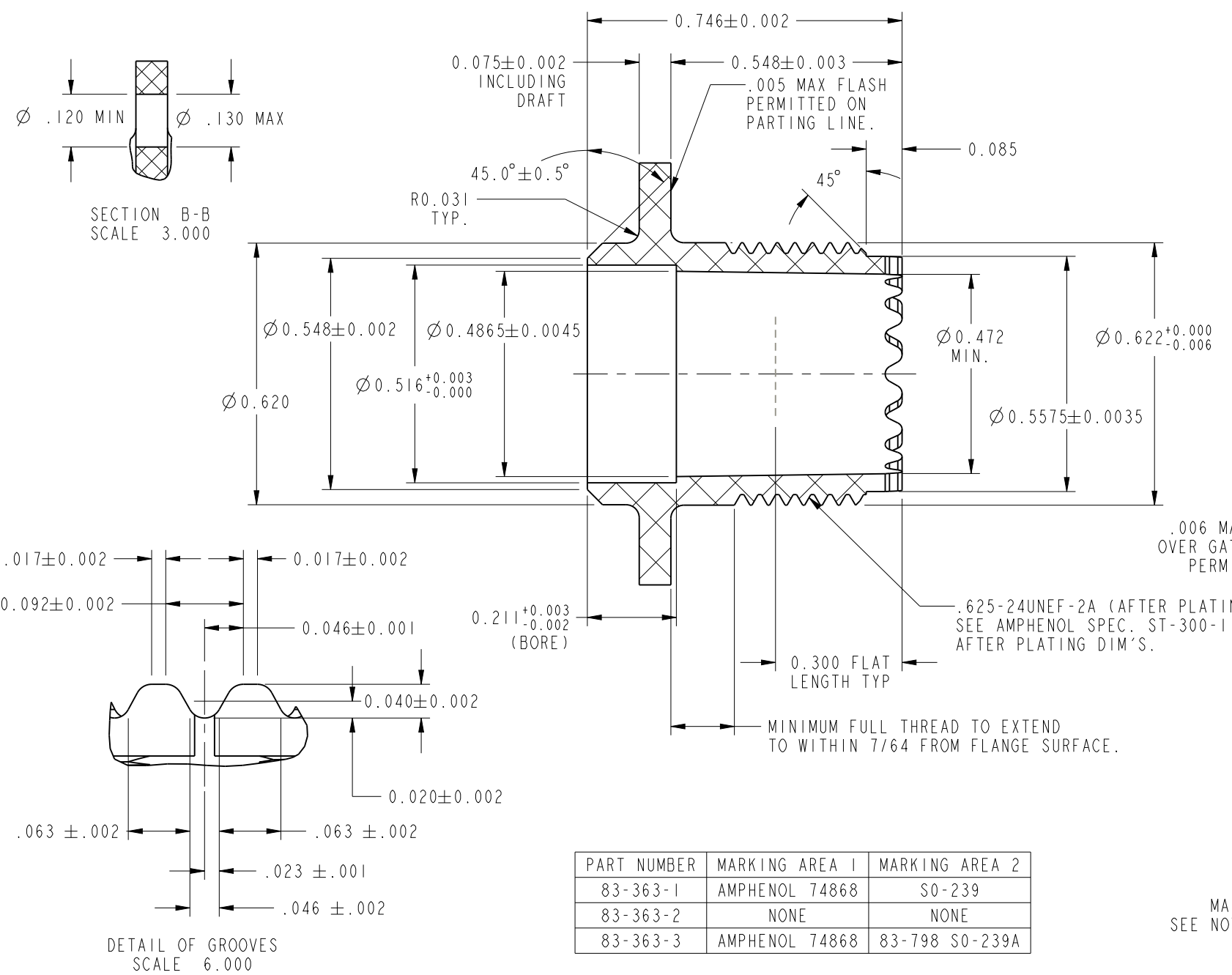

PART NUMBER	MARKING AREA 1	MARKING AREA 2
83-363-1	AMPHENOL 74868	S0-239
83-363-2	NONE	NONE
83-363-3	AMPHENOL 74868	83-798 S0-239A

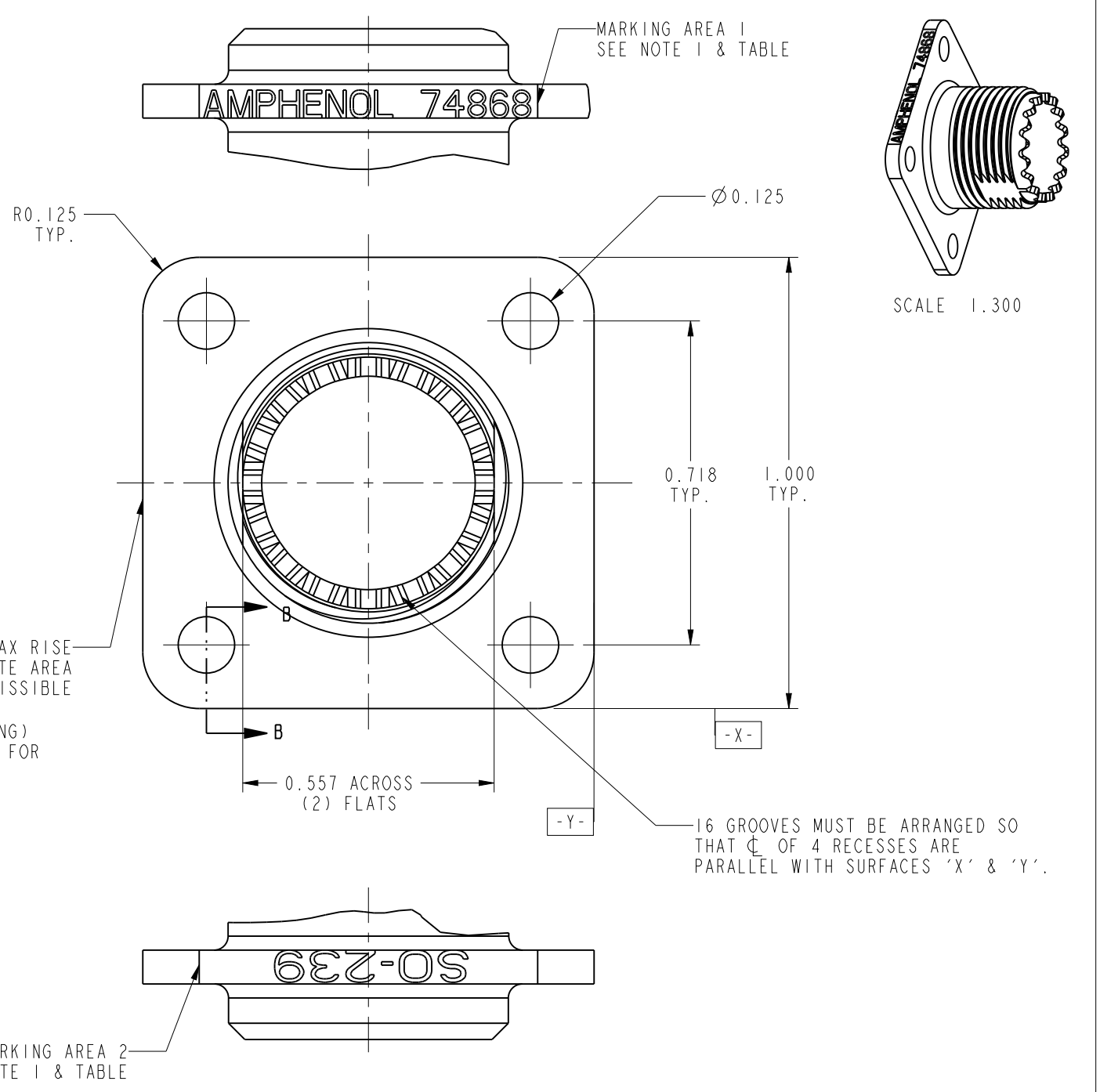

UNLESS OTHERWISE SPECIFIED, DIMENSIONS ARE IN INCHES AND TOLERANCES ARE: 2 PLACE DECIMAL $\pm .015$ (0,381 mm) 3 PLACE DECIMAL $\pm .005$ (0,127 mm) ANGLES $\pm 1^\circ$	MATERIAL ZINC DIE CAST #3 ZAMAC FINISH: NOTE 2	DRAWN C. McGRATH	DATE 01-Nov-01	TITLE RECEPTACLE SHELL	Amphenol RF Danbury, CT, USA Tainan, Taiwan Shenzhen, China www.amphenolrf.com		
	REFERENCE	ENGINEER O. BARTHELME	DATE 01-Nov-01				
NOTICE - These drawings, specifications, or other data (1) are, and remain the property of Amphenol Corp. (2) must be returned upon request; and (3) are confidential and not to be disclosed to any person other than those to whom they are given by Amphenol Corp. The furnishing of these drawings, specifications, or other data by Amphenol Corp., or to any other person to anyone for any purpose is not to be regarded by implication or otherwise in any manner licensing, granting rights or permitting such holder or any other person to manufacture, use or sell any product, process or design, patented or otherwise, that may in any way be related to or disclosed by said drawings, specifications, or other data.		APPROVED O. BARTHELME	DATE 14-Nov-01		SCALE: 3.0:1 SHEET 1 OF 2		
		CAD FILE I:\BODY\83-363-X			CODE ID 74868	DWG SIZE B	DRAWING NO. 83-363-X

SURFACE AREA = 4.522 SQ. IN.
VOLUME = 0.117 CU. IN.

X-ON Electronics

Largest Supplier of Electrical and Electronic Components

Click to view similar products for [RF Connectors / Coaxial Connectors](#) category:

Click to view products by [Amphenol](#) manufacturer:

Other Similar products are found below :

[8915-1511-000](#) [89674-0827](#) [6001-7071-019](#) [6002-7051-003](#) [6002-7551-202](#) [6059674-1](#) [619550-1](#) [630059-000](#) [M39030/3-01N](#) [6500-7071-046](#) [6769](#) [CX050L2AQ](#) [7002-1542-011](#) [7004-1512-000](#) [7009-1511-004](#) [7010-1511-000](#) [7029-1511-060](#) [7101-1541-010](#) [7101-1571-002](#) [7105-1521-002](#) [7145-1521-002](#) [7203-1571-003](#) [7209-1511-011](#) [7210-1511-015](#) [7210-1511-019](#) [73137-5015](#) [73216-2241](#) [7325-1512-000](#) [73404-2300](#) [7405-1521-005](#) [7405-1521-802](#) [7406-1521-005](#) [8527](#) [8547](#) [FS11V](#) [8808-1511-001](#) [9049-9513-000](#) [9074-9513-000](#) [9101-9573-002](#) [910A205F](#) [9130-9573-002](#) [PL11SC-026](#) [PL375-33](#) [PL40-5](#) [PL71-9](#) [PL74C-221](#) [PL75MC-217](#) [PL803-7](#) [980-8666-005](#) [1200690078](#)