

PRODUCT NO.

SEE TABLE

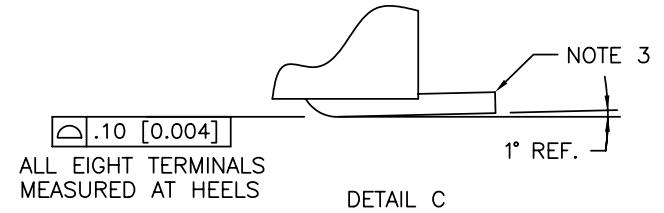

THE MYLAR SEE NOTE 7 ONLY FOR 87545-XXX1C/XXX1CLF

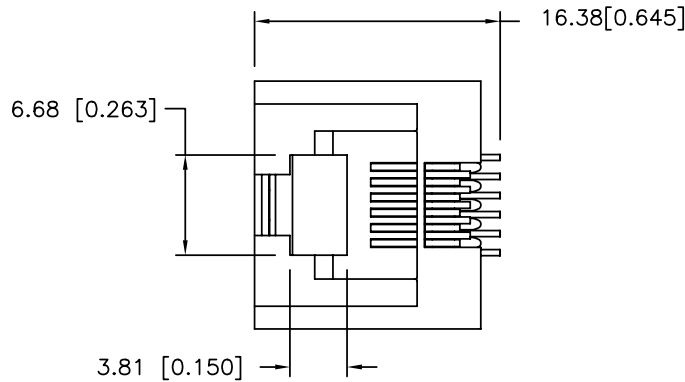
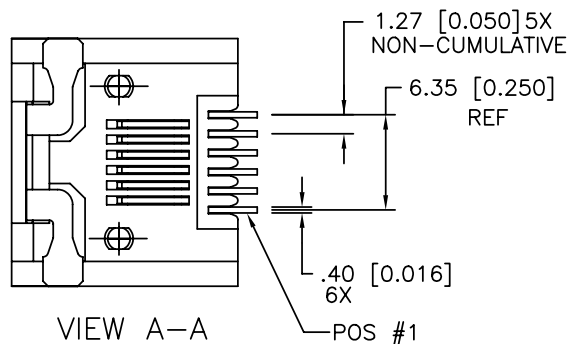
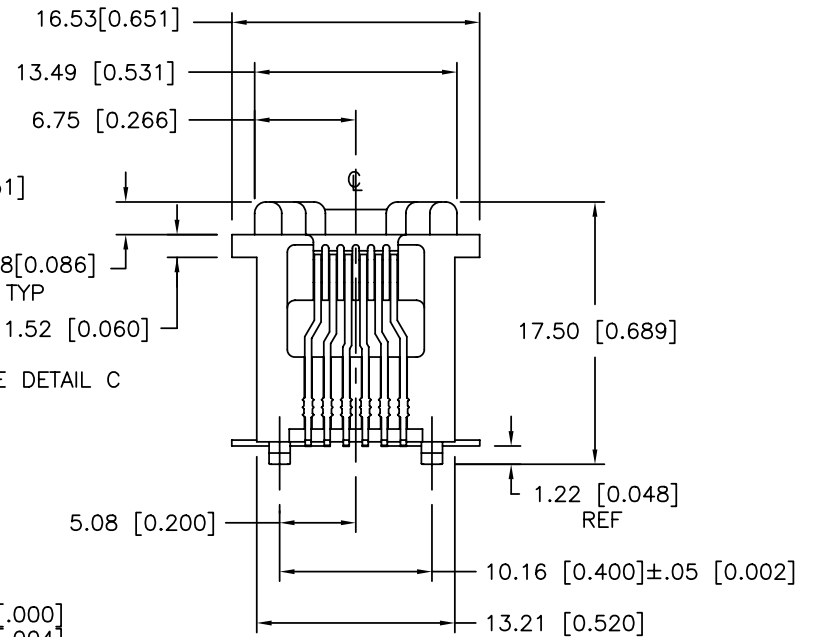
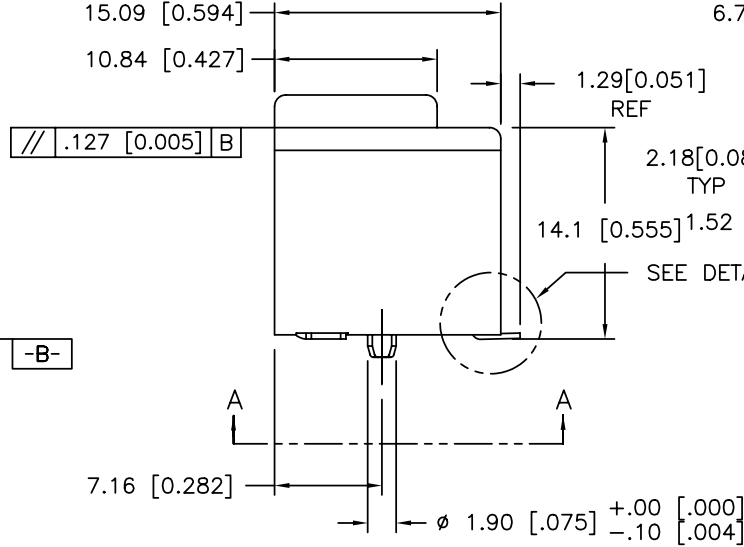
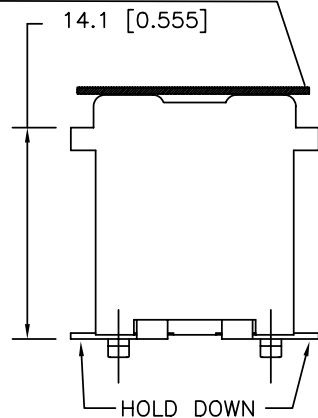

mat'l. code				tolerances unless otherwise specified		CUSTOMER COPY		FCI www.fciconnect.com	
ltr	ecn no	dr	date	linear	.X±.3/.XX±.01		projection	title	
J	V81474	RGD	9/15/96		.XX±.13/.XXX±.005			A-SMT ASSEMBLY VERT 6 POS	
K	V12666	LP	1/10/02	angles	.XXX±.051/.XXX±.0020		MM/INCH	product family MOD JACK	
L	N05-0035	YS	02/18/05		0° ±2'			size dwg no	
M	N05-0142	ZC	6/2/05	dr	S.DUESTERHOEFT	3/20/96	code		
N	N07-0217	WG	09/07/07	enr	Y.BELOPOLSKY	3/20/96	213		
P	N08-0194	SH	09/08/09	chr	Y.BELOPOLSKY	7/8/96	sheet		
				appd	Y.BELOPOLSKY	7/8/96	1 of 2		
sheet index	revision sheet	N 1	N 2			scale 1:1		A4	
						A4		87545	

Tous droits strictement reserves. Reproduction ou communication a des tiers interdite sous quelque forme que ce soit sans autorisation écrite du propriétaire. Propriete de c FCI. Droits de reproduction FCI.

All rights strictly reserved. Reproduction or issue to third parties in any form whatever is not permitted without written authority from the proprietor. Property of FCI. Copyright FCI.

Tous droits strictement réservés. Reproduction ou communication à des tiers interdite sous quelque forme que ce soit sans autorisation écrite du propriétaire. Propriété de c FCI. Droits de reproduction FCI.



All rights strictly reserved. Reproduction or issue to third parties in any form without the written authorization of FCI. Copyright FCI.

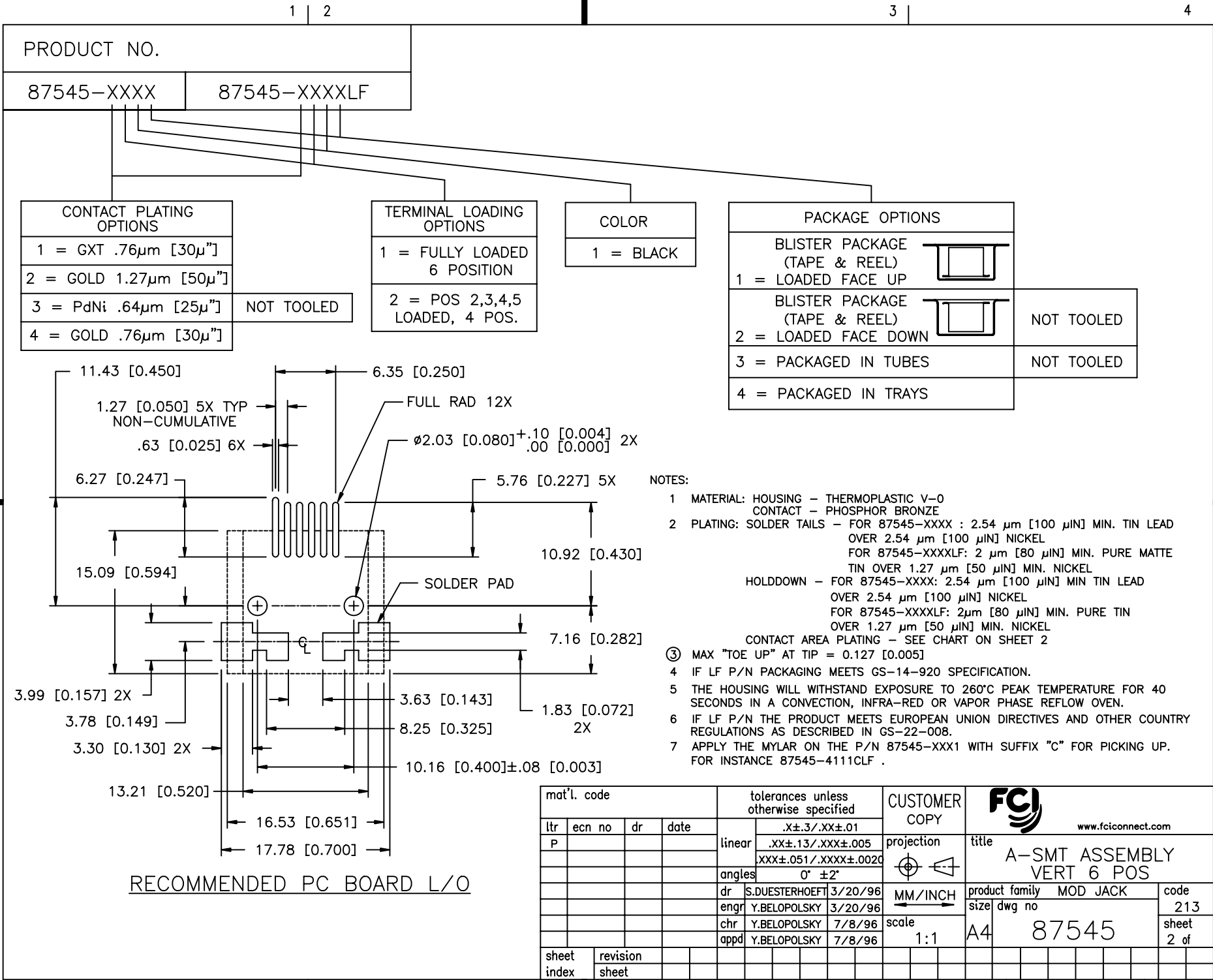

PRODUCT NO.
87545-XXXX 87545-XXXXLF

CONTACT PLATING OPTIONS	
1 = GXT .76µm [30µ"]	
2 = GOLD 1.27µm [50µ"]	
3 = PdNi .64µm [25µ"]	NOT TOOLED
4 = GOLD .76µm [30µ"]	

TERMINAL LOADING OPTIONS	
1 = FULLY LOADED 6 POSITION	
2 = POS 2,3,4,5 LOADED, 4 POS.	

COLOR
1 = BLACK

PACKAGE OPTIONS	
BLISTER PACKAGE (TAPE & REEL) 1 = LOADED FACE UP	
BLISTER PACKAGE (TAPE & REEL) 2 = LOADED FACE DOWN	
3 = PACKAGED IN TUBES	NOT TOOLED
4 = PACKAGED IN TRAYS	NOT TOOLED

- NOTES:
- MATERIAL: HOUSING - THERMOPLASTIC V-0
CONTACT - PHOSPHOR BRONZE
 - PLATING: SOLDER TAILS - FOR 87545-XXXX : 2.54 µm [100 µIN] MIN. TIN LEAD OVER 2.54 µm [100 µIN] NICKEL
FOR 87545-XXXXLF: 2 µm [80 µIN] MIN. PURE MATTE TIN OVER 1.27 µm [50 µIN] MIN. NICKEL
HOLDDOWN - FOR 87545-XXXX: 2.54 µm [100 µIN] MIN TIN LEAD OVER 2.54 µm [100 µIN] NICKEL
FOR 87545-XXXXLF: 2µm [80 µIN] MIN. PURE TIN OVER 1.27 µm [50 µIN] MIN. NICKEL
CONTACT AREA PLATING - SEE CHART ON SHEET 2
 - MAX "TOE UP" AT TIP = 0.127 [0.005]
 - IF LF P/N PACKAGING MEETS GS-14-920 SPECIFICATION.
 - THE HOUSING WILL WITHSTAND EXPOSURE TO 260°C PEAK TEMPERATURE FOR 40 SECONDS IN A CONVECTION, INFRA-RED OR VAPOR PHASE REFLOW OVEN.
 - IF LF P/N THE PRODUCT MEETS EUROPEAN UNION DIRECTIVES AND OTHER COUNTRY REGULATIONS AS DESCRIBED IN GS-22-008.
 - APPLY THE MYLAR ON THE P/N 87545-XXX1 WITH SUFFIX "C" FOR PICKING UP. FOR INSTANCE 87545-4111CLF .

RECOMMENDED PC BOARD L/O

mat'l. code		tolerances unless otherwise specified		CUSTOMER COPY		FCI	
ltr	ecn no	dr	date	linear	.X±.3/.XX±.01	projection	title
P					.XX±.13/.XXX±.005		A-SMT ASSEMBLY VERT 6 POS
				angles	0° ±2'	MM/INCH	product family MOD JACK
				dr	S.DUESTERHOEFT 3/20/96	scale 1:1	code 213
				enr	Y.BELOPOLSKY 3/20/96		size dwg no
				chr	Y.BELOPOLSKY 7/8/96		87545
				appd	Y.BELOPOLSKY 7/8/96		sheet 2 of
sheet index	revision sheet						

X-ON Electronics

Largest Supplier of Electrical and Electronic Components

Click to view similar products for [Modular Connectors](#) / [Ethernet Connectors](#) category:

Click to view products by [Amphenol](#) manufacturer:

Other Similar products are found below :

[RJE231881317T](#) [MP1010RX-1000](#) [MP44RX-1000](#) [GAX-3-66](#) [GAX-8-62](#) [93606-0253](#) [GD-A-44](#) [GDCX-PA-66-50](#) [GDCX-PN-64](#) [GDCX-PN-66](#) [GDCX-PN-66-50](#) [GDLX-A-66](#) [GDLX-A-88](#) [GDLX-N-66](#) [GDLX-S-88K](#) [GDTX-S-88-50](#) [GDX-PA-1010](#) [GLX-A-44](#) [GLX-N-1010M-BLK](#) [GLX-N-44M](#) [GLX-S-88M-BLK](#) [GMX-N-1010](#) [GMX-S-1010](#) [GMX-S-66](#) [GMX-SMT2-N-1010](#) [GMX-SMT2-N-64-50](#) [GMX-SMT2-S6-88](#) [GMX-SMT4-N-88](#) [GPX-2-64](#) [GRT1-BT1-5](#) [GSGX-N-2-88](#) [GSX-NS2-88-3.05](#) [GSX-NS2-88-3.05-50](#) [GSX-NS-88-3.05-30](#) [GSX-NS-88-3.05-50](#) [GSX-NS-88-3.68](#) [1-1775629-2](#) [GWLX-S-88-GR](#) [GWLX-S9-88-YG](#) [1300500326](#) [1300500227](#) [1300530003](#) [1300570002](#) [1324640-4](#) [RJ11FTVC2G](#) [RJ11FTVC2N](#) [RJFTVX2SA1G](#) [132764-001](#) [1400000](#) [1413176](#)