

NOTES:

1. MATERIALS AND FINISHES:
 REAR BODY - BRASS, GOLD PLATED
 FRONT BODY, CONTACT - BeCu, GOLD PLATED
 INSULATOR - PTFE
 2. ELECTRICAL:
 A. IMPEDANCE: 50 OHM
 3. MECHANICAL:
 A. DURABILITY: 500 CYCLES MIN.
 B. TEMPERATURE RANGE: -65° C TO +165° C
 4. PACKAGING:
 A. QUANTITY: SINGLE PACK
 B. 2 GASKETS, BRAID CLAMP AND CLAMP NUT ARE PACKAGED LOOSE.
 C. MARKING: BAG TO BE MARKED
 "AMPHENOL RF, 901-368-12, AND DATE CODE"
5. SHOWS CABLE ENTRY DIMENSIONS.
6. FOR CABLE ASSEMBLY INSTRUCTIONS, SEE SHEET 12 OF AMPHENOL SPEC. 349-50114
 7. CUSTOMER NOTE: SOLDER CONTACT TO CABLE AND CAP TO BODY

THIRD ANGLE PROJ.

REVISIONS				
REV	DESCRIPTION	DATE	ECO	APPR
--	RELEASE TO MFG.	----	----	----
T	REDRAWN IN PRO-E AND COD SHEET ADDED	10/11/12	49251	KR
U	MOVED STAMP PER SHT 1	12/10/14	50278	CPM

MIL-C-39012 INSPECTION

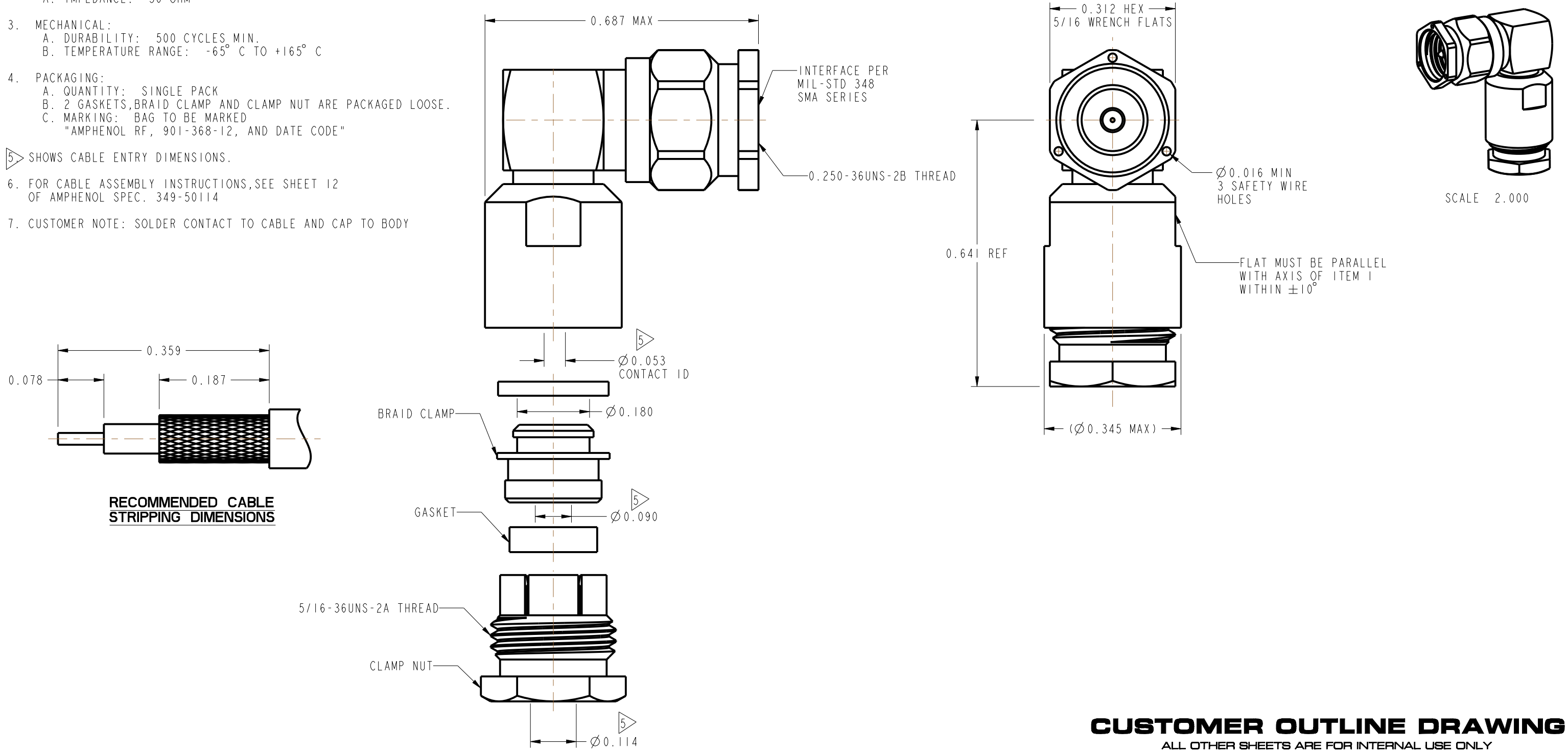

CUSTOMER OUTLINE DRAWING
 ALL OTHER SHEETS ARE FOR INTERNAL USE ONLY

UNLESS OTHERWISE SPECIFIED, DIMENSIONS ARE IN INCHES AND TOLERANCES ARE: 2 PLACE DECIMAL 3 PLACE DECIMAL ANGLES ±.015 (0.381 mm) ±.005 (0.127 mm) ± 1°	MATERIAL	DRAWN	DATE	TITLE SMA 90° PLUG CRIMP TYPE FOR RG-174/U & RG-188/U RG-316/U CABLE		Amphenol RF www.amphenolrf.com	
	SEE NOTES	KARTHIK R	05-Sep-12				
NOTICE - These drawings, specifications, or other data (1) are, and remain the property of Amphenol corp. (2) must be returned upon request; and (3) are confidential and not to be disclosed to any person other than those to whom they are given by Amphenol Corp. the furnishing of these drawings, specifications, or other data by Amphenol Corp., or to any other person to anyone for any purpose is not to be regarded by implication or otherwise in any manner licensing, granting rights to permitting such holder or any other person to manufacture, use or sell any product, process or design, patented or otherwise, that may in any way be related to or disclosed by said drawings, specifications, or other data.	REFERENCE	ENGINEER	DATE	SCALE: 4.1:1.0 SHEET 2 OF 2		DRAWING NO. 901-368-12	
	DOR 311163-51 MIL-C-39012/56-4007 CONFIGURATION LEVEL: In Work	K. CAPOZZI	05-Sep-12	9/12/12	DWG SIZE	REV	ITEM NO. 901-368-12
	FINISH				B	U	PART NO. 901-368-12

X-ON Electronics

Largest Supplier of Electrical and Electronic Components

Click to view similar products for [Adafruit Accessories](#) category:

Click to view products by [Amphenol](#) manufacturer:

Other Similar products are found below :

[3015](#) [3209](#) [2998](#) [3561](#) [2974](#) [3182](#) [3290](#) [2755](#) [3560](#) [3562](#) [2503](#) [3011](#) [3597](#) [3048](#) [2776](#) [3299](#) [2973](#) [2922](#) [2868](#) [2958](#) [2860](#) [2836](#) [2686](#)
[2968](#) [2972](#) [2969](#) [2871](#) [2851](#) [2873](#) [2895](#) [3610](#) [2939](#) [3568](#) [2869](#) [2866](#) [3551](#) [2858](#) [2855](#) [3590](#) [3447](#) [3353](#) [2744](#) [3585](#) [3584](#) [3552](#) [3484](#)
[2865](#) [2782](#) [3577](#) [FLUKE FL-45 EX](#)