

Connectors

FIBER OPTIC CATALOG

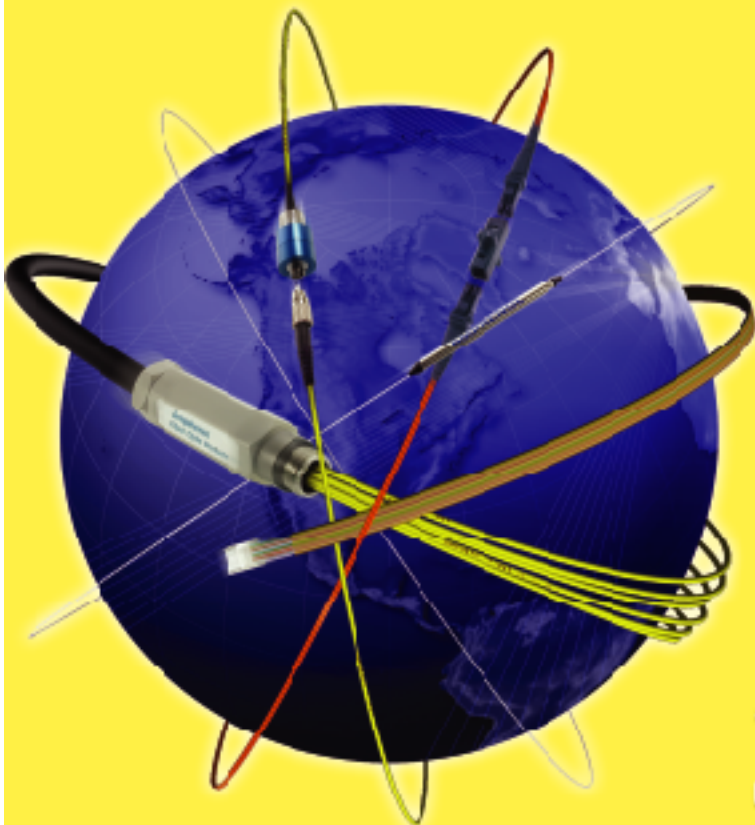
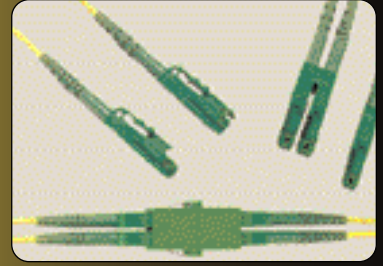

Amphenol[®]
FIBER OPTIC PRODUCTS
60 Years of Interconnect Knowledge

Connectors & Adapters

Experience. With 60 years of interconnect experience, from the first industry standard 905 Series SMA to the advanced LX.5 small form-factor connector system and high density MPO multi-fiber interconnects, Amphenol leads innovation in fiber optic connector technology.

Product Breadth. Amphenol offers a complete line of fiber optic connectors and adapters including SMA, ST, FC, SC, LC, LX.5, MPO and Hybrilink™ converting adapters.

Total Quality Performance. Stringent quality assurance systems exceed the ISO 9001 requirements and ensure consistent quality products regardless of manufacturing location. Total quality means understanding who the customer is, what the requirements are and meeting those requirements without error, on time, every time.

Highest Quality Materials. Top grade ceramic ferrules ensure the best optical performance and polishing yield. Carefully selected engineering plastics withstand the most demanding environmental stress conditions. High quality materials ensure the long-term reliability and performance of Amphenol connectors.

Performance and Reliability. Amphenol's experience in military and aerospace interconnect dictates 100% field reliability. Collaborative design review processes for new product development and a state of the art in-house environmental testing lab certify each Amphenol design and production process.

Creative and Functional Designs. You specify the functionality of the interconnect and our talented, enthusiastic and friendly mechanical and optical engineers work together to develop your solution. Design creativity and a deep understanding of mechanics, optics, and your unique application ensure a functional and manufacturable design.

Responsiveness and Speed to Market. Vertical and virtual integration (supplier partnerships) of key manufacturing processes allow for customer specific production connector parts in less than four weeks: Stamping, Die Cast, Turning, Plastic and Metal Injection Molding, Plating, Reel to Reel Etching, Photolithographic and Laser Micro-Machining.

Manufacturing Expertise and Delivery Precision. Amphenol Delivers. Meticulous attention to capacity and material planning allow Amphenol to meet our committed ship dates on time, every time. Amphenol knows volume manufacturing. Rapid ramp-up of challenging new products is one of our strengths.

Experience Across Industries. From aerospace to oil exploration, from the Internet to medical devices, Amphenol is a preferred supplier to leading customers across many industries.

Global Presence. With 40 manufacturing facilities on 3 continents, and a local presence in over 30 countries, our responsive and creative team can solve your interconnect challenge anywhere in the world.

Amphenol Interconnect Innovation Delivered Worldwide On-time.

Table of Contents

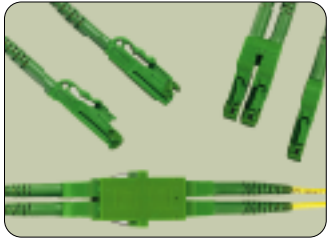

LX.5 Connectors & Adapters
Page 3-4

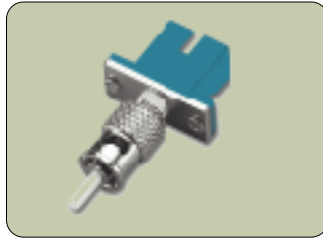

HybriLink Plug Style Adapters
Page 5-6



HybriLink Bulkhead Adapters
Page 7-8



MPO Adapters
Page 9-11

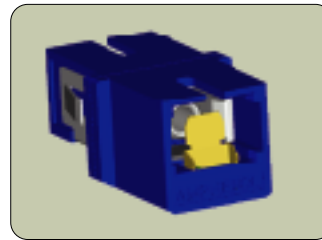

SC Shuttered Adapter
Page 12



SC Connectors & Adapters
Page 13-16



FC Connectors & Adapters
Page 17-20

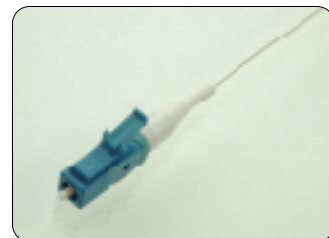

LC Connectors & Adapters
Page 21-22



ST Connectors & Adapters
Page 23-24



SMA Connectors &
Adapters/Receptacles
Page 25-28

LX.5® Connectors & Adapters

Amphenol's LX.5 connectors offer double the density of standard SC connectors in a feature-rich, mechanically robust design.

The connector interface features an **integrated shutter system** that protects the fiber endface from damage and contamination during handling and installation. It is automatically actuated when mating to an LX.5 adapter, requiring no manual operation by the end user. Using high precision and time tested zirconia ferrules, performance and reliability are guaranteed.

The **low-profile latching system**, with a wide landing area for depressing the latch, allows for smooth mating and de-mating of the connector. With virtually no protrusion from the connector body, the low-profile LX.5 latch prevents tangling of the fiber cables and maintains a rugged connection without sacrificing critical space requirements in today's dense optical packaging.

Amphenol's current connector styles include APC, tunable singlemode UPC and multimode versions for use with 2.0mm, 1.70mm or 900µm cable. It is possible to make a duplex connector or retrofit a simplex cable assembly by simply inserting an inexpensive duplex clip between two simplex connectors. This assists in managing connector inventory by reducing the number of connector part numbers needed as requirements change.

® LX.5 is a registered trademark of ADC Telecommunications

Intermateability:
EIA/TIA FOCIS 13 pending approval.

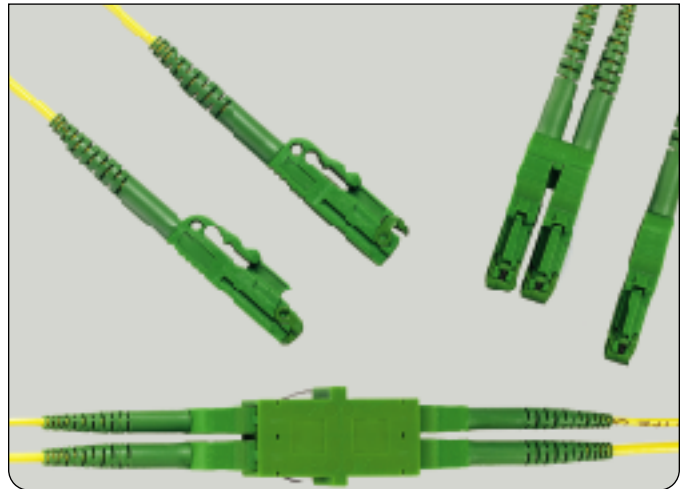

LX.5 Connectors & Adapters

Common Specifications

Insertion Loss (typical):

Singlemode (untuned): ≤ UPC 0.10dB

≤ APC 0.20dB

Multimode: ≤ 0.20dB

Material:

Ferrule: zirconia

Alignment Sleeve: zirconia or phosphor bronze
(adapters)

Connector/Adapter Bodies:

UL 94V-0 rated thermoplastic to meet industry
standard flammability ratings.

Environmental:

Operating Temperature: -40 to +75° C

Storage Temperature: -40 to +85° C

*Meets Telcordia GR-326-CORE, Issue 3

Mating Durability:

200 optical mating and 500 mechanical tests per
Telcordia GR-326-CORE, Issue 3

Recommended Cables:

1.70mm, 2.0mm, or 900µm

Ordering Information

LX.5 Connectors				
Part #	Description	Recommended Cable Diameter	Body Color	Boot Color
961-103-5006	LX.5 APC connector, 126µm zirconia ferrule	1.70mm	green	green
961-103-5106	LX.5 APC connector, 126µm zirconia ferrule	2.0mm	green	green
961-103-5206	LX.5 APC connector, 126µm zirconia ferrule	900µm	green	green
961-111-5006	LX.5 singlemode connector, 126µm zirconia ferrule, tunable	1.70mm	blue	blue
961-111-5106	LX.5 singlemode connector, 126µm zirconia ferrule, tunable	2.0mm	blue	blue
961-111-5206	LX.5 singlemode connector, 126µm zirconia ferrule, tunable	900µm	blue	blue
961-101-5007	LX.5 multimode connector, 127µm zirconia ferrule	1.70mm	beige	beige
961-101-5107	LX.5 multimode connector, 127µm zirconia ferrule	2.0mm	beige	beige
961-101-5207	LX.5 multimode connector, 127µm zirconia ferrule	900µm	beige	beige

Accessories	
Part #	Description
961-0001	Duplex clip, singlemode, blue
961-0002	Duplex clip, multimode, beige
961-0003	Duplex clip, APC, green

LX.5 Adapters				
Part #	Description	Alignment Sleeve Material	Flange Type	Housing Color
961-120-5001	LX.5 APC duplex, shuttered adapter	zirconia	screw mount	green
961-120-5002	LX.5 APC duplex, shuttered adapter	zirconia	small flange	green
961-120-5101	LX.5 singlemode duplex, shuttered adapter	zirconia	screw mount	blue
961-120-5102	LX.5 singlemode duplex, shuttered adapter	zirconia	small flange	blue
961-120-5211	LX.5 multimode duplex, shuttered adapter	phosphor bronze	screw mount	beige
961-120-5212	LX.5 multimode duplex, shuttered adapter	phosphor bronze	small flange	beige

LX.5 Mechanical Dimensions

Connector (1.70mm):

961-1XX-5XXX

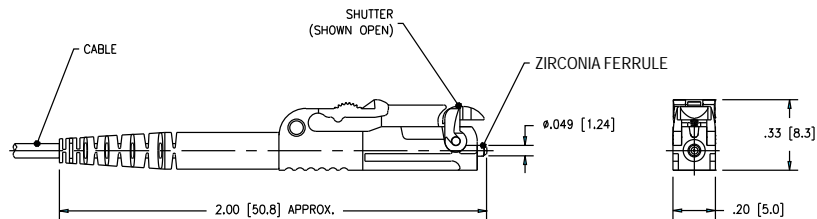

Adapter
(with screw mount flange):

961-120-5XXX

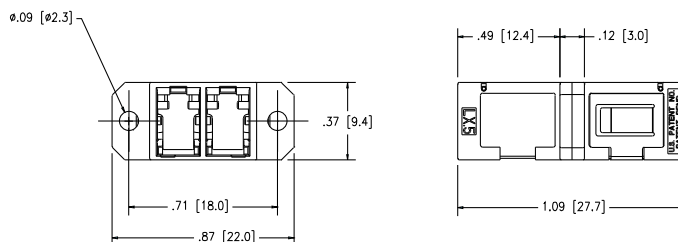

Hybrilink™ Adapter: Plug Style Singlemode and Multimode









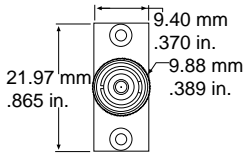
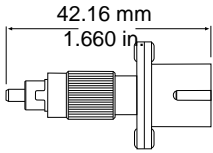

Solve interoperability problems by using Amphenol Fiber Optic Products Hybrilink™ adapters in situations requiring the coupling of dissimilar connector styles or when using existing cable assemblies with new equipment or new cables with existing equipment.

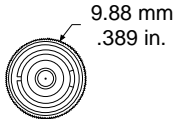
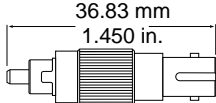
These compact, male-to-female configured adapters economically adapt connector interfaces to new equipment, upgrade distribution panels, and eliminate the need to re-terminate cable assemblies.

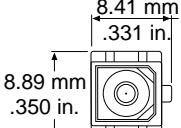
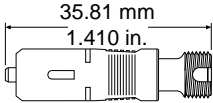
Hybrilinks™ are optically tested and available in singlemode (9/125µm) and multimode (50/125 and 62.5/125µm) versions, in most interface designs.

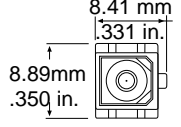
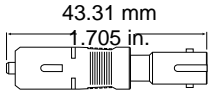
Features

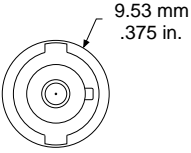
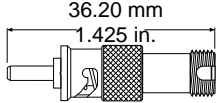
- ▶ Low insertion loss
- ▶ Repeatability
- ▶ Thermal stability
- ▶ Low return loss

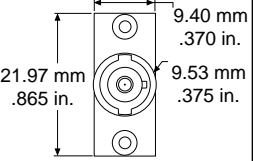
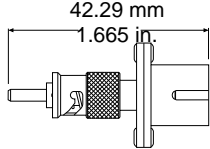
	FC(M) to SC(F) 	
	FC(M) to ST(F) 	
	SC(M) to FC(F) 	
	SC(M) to ST(F) 	
	ST(M) to FC(F) 	
	ST(M) to SC(F) 	

Hybrilink™ Adapter: Plug Style

Common Specifications

Insertion Loss Singlemode dB (max) at 1310 and 1550nm:	≤ 0.5dB
Insertion Loss Multimode dB (max) at 850 and 1300nm:	≤ 0.8dB
Return Loss Singlemode PC dB (minimum/typical):	-50/-55dB
Polarization Dependent Loss:	≤ 0.1dB
Operating Temperature Telcordia GR-63-CORE:	-5 to +50°C
Storage Temperature:	-40 to +70°C

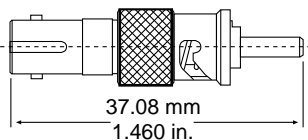
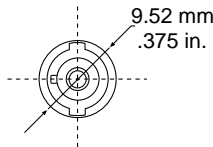
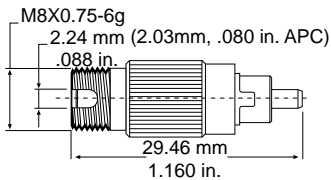
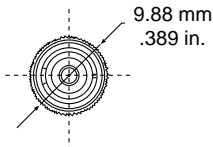
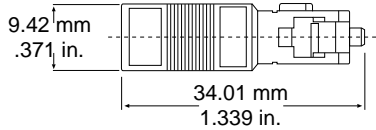
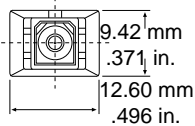

Hybrilink™ Adapters: Plug Style

Type	Body Material	Ferrule Material / Diameter (mm)	Sleeve Material	Weight/100 pieces w/dustcaps g (oz)
FC to SC	Molded Thermoplastic & Nickel Plated Brass	Zirconia 2.50	Zirconia	1141 (40)
FC to ST	Nickel Plated Brass	Zirconia 2.50	Zirconia	968 (34)
SC to FC	Molded Thermoplastic & Nickel Plated Brass	Zirconia 2.50	Zirconia	701 (25)
SC to ST	Molded Thermoplastic & Nickel Plated Brass	Zirconia 2.50	Zirconia	737 (26)
ST to FC	Nickel Plated Brass	Zirconia 2.50	Zirconia	907 (32)
ST to SC	Molded Thermoplastic & Nickel Plated Brass	Zirconia 2.50	Zirconia	1030 (36)
SC to SC	Nickel Plated Brass Zinc Alloy	Zirconia 2.50	Zirconia	879 (31)
FC to FC	Nickel Plated Brass	Zirconia 2.50	Zirconia	822 (29)
ST to ST	Nickel Plated Brass	Zirconia 2.50	Zirconia	850 (30)

Singlemode PART NUMBER	M F 71-S8-XX
XX =	Connector Codes

T	SC (PC)
Q	SC (APC)*
P	FC (PC)
U	FC (APC)*
R	ST (PC)

Example: 71-S8-PR
Hybrilink™ Adapter, Singlemode,
FC (PC) male to ST (PC) female

*Male end and female end must be same connector style.

Multimode PART NUMBER	M F 71-M6-XX 71-M5-XX
XX =	Connector Codes

Z	SC (PC)
E	FC (PC)
G	ST (PC)

Example: 71-M6-EZ
Hybrilink™ Adapter, Multimode,
FC (PC) male to SC (PC) female

Hybrilink™ Adapter: Bulkhead Style

For a practical and efficient interconnect method of joining dissimilar connectors, turn to Hybrilink™ bulkhead adapters from Amphenol Fiber Optic Products.

Available flanged or non-flanged, these compact adapters feature a wide variety of female-to-female interfaces that form a single piece of easy-to-install interconnect hardware. The Hybrilink™ bulkhead adapters are perfect for testing applications and an efficient solution to the problem of mismatched connections in the field.

Features

- Low insertion loss
- Repeatability
- Thermal stability

FC(F) to ST(F)

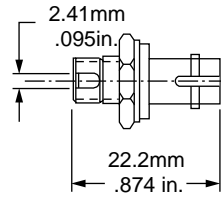

Part number: 88-FJ-7A, coupling nut on FC side

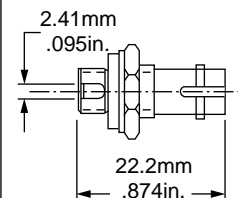
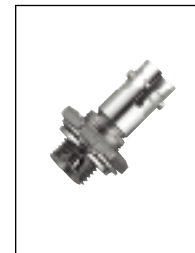

Part number: 88-FJ-7B, coupling nut on ST side

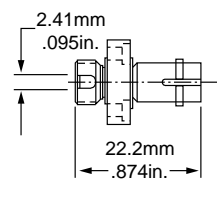

Part number: 88-FJ-1A, mount from ST side

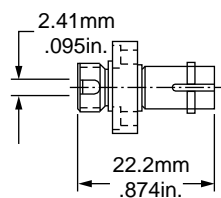
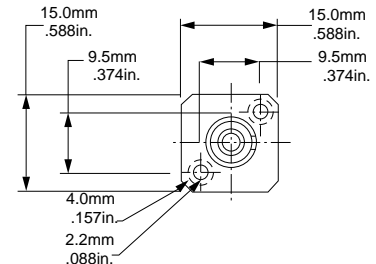

Part number: 88-FJ-1B, mount from FC side

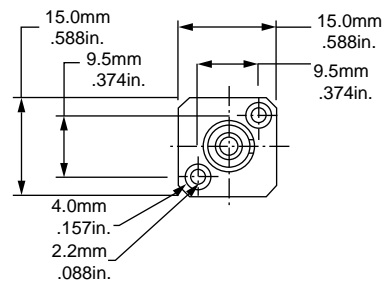

SC(F) to FC(F)

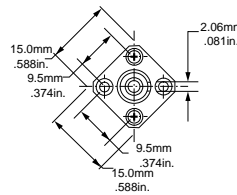
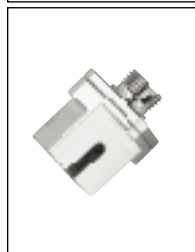

Part number: 88-QU-1; mount from FC side, APC style

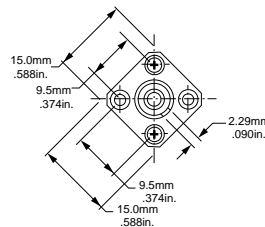
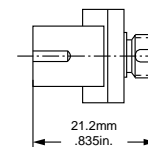

Part number: 88-FY-1; mount from FC side

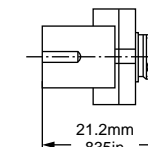

Hybrilink™ Adapter: Bulkhead Style

ST (F) to SMA (F) 905 or 906*

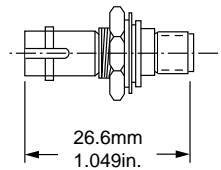
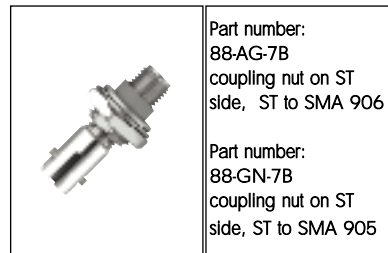
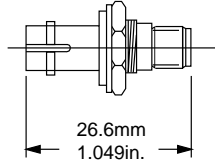
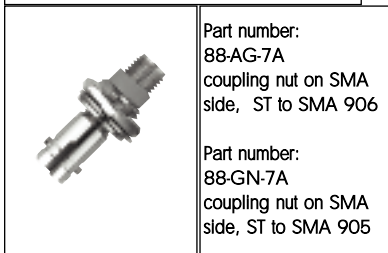

* Blue ring on piece indicates SMA 905. Green ring on piece indicates SMA 906.

Common Specifications

Insertion Loss:	Dependent on quality of polish on individual endfaces
Return Loss:	Dependent on quality of polish on individual endfaces
Operating Temperature:	-40 to +75°C
Storage Temperature:	-40 to +85°C
Repeatability:	± 0.20dB
Thermal Stability:	± 0.20dB

Hybrilink™ Adapters: Bulkhead Style

Part Number	Type	Body Material	Sleeve Material	Weight/100 pieces w/dustcaps g (oz)
88-FJ-7A	FC (F) to ST (F)	Nickel Plated Brass	Zirconia	700
88-FJ-7B	FC (F) to ST (F)	Nickel Plated Brass	Zirconia (Diagonal Cut)	(25)
88-FJ-1A	FC (F) to ST (F)	Nickel Plated Brass	Zirconia	1040
88-FJ-1B	FC (F) to ST (F)	Nickel Plated Brass	Zirconia (Diagonal Cut)	(36)
88-QU-1	SC/APC (F) to FC/APC (F)	Nickel Plated Brass /die cast zinc	Zirconia	980 (35)
88-FY-1	SC (F) to FC (F)	Nickel Plated Brass /die cast zinc	Zirconia	1060 (37)
88-FY-1-P	SC (F) to FC (F)	Nickel Plated Brass /die cast zinc	Phosphor Bronze	740 (25)
88-AG-7A	906 SMA (F) to ST (F)	Nickel Plated Brass	Delrin®	740
88-AG-7B	906 SMA (F) to ST (F)	Nickel Plated Brass	Delrin® /stainless steel	(26)
88-GN-7A	905 SMA (F) to ST (F)	Nickel Plated Brass	Delrin®	740
88-GN-7B	905 SMA (F) to ST (F)	Nickel Plated Brass	Delrin® /stainless steel	(26)

Hybrilink™ Adapters: Bulkhead Style

Part Number	Description
88-FJ-7A	FC (F) to ST (F) coupling nut on FC side
88-FJ-7B	FC (F) to ST (F) coupling nut on ST side
88-FJ-1A	FC (F) to ST (F) mount from ST side
88-FJ-1B	FC (F) to ST (F) mount from FC side
88-QU-1	SC/APC (F) to FC/APC (F) mount from FC side

Hybrilink™ Adapters: Bulkhead Style

Part Number	Description
88-FY-1	SC (F) to FC (F) mount from FC side
88-FY-1-P	SC (F) to FC (F) mount from FC side (phosphor bronze sleeve)
88-AG-7A	ST (F) to 906 SMA (F) coupling nut on SMA side
88-AG-7B	ST (F) to 906 SMA (F) coupling nut on ST side
88-GN-7A	ST (F) to 905 SMA (F) coupling nut on SMA side
88-GN-7B	ST (F) to 905 SMA (F) coupling nut on ST side

MPO Adapters

The MT ferrule has changed fiber optic packaging dramatically with the increase in density up to 24 fibers in a single connector. With this density increase, performance cannot afford to be compromised.

That is why Amphenol developed the 955 series MPO adapter family. Made in both die-cast and industry compliant thermoplastics, the MPO adapter is precision manufactured to insure intermateability with industry standard assemblies and connectors. Available with various flange styles, Amphenol MPO adapters are able to meet the challenges and mechanical requirements of highly dense system designs while maintaining industry standard footprints.

The die-cast version was designed to meet the growing need for connectors to assist in preventing excessive EMI leaks from front panels in telecommunication and data communication equipment. As these devices become faster and more dense, this type of protection becomes more important for overall system performance. The 360-degree outside flange completely covers the panel cutout to insure minimal leaks inherent to front panel designs. Amphenol's MPO die-cast adapter is constructed with a one-piece body featuring a solid backwall with a "window" to allow the mating of the MT ferrules. This minimizes the aperture of the adapter for additional EMI protection.

An optional innovative feature of Amphenol MPO adapters is the fully automatic shutter. This internal shutter mechanism, located on both sides of the adapter, requires no manual actuation to receive the benefit of eye safety by simply inserting the MPO connector. The unique stepped design of the shutter prevents the ferrule endface from making contact with the shutter while mating the connector.

The flexible and practical design features, coupled with Amphenol's MPO cable assemblies, provide the perfect multi-fiber interconnect solution.

® MTP is a registered trademark of US Conec



MPO Die-cast Adapter

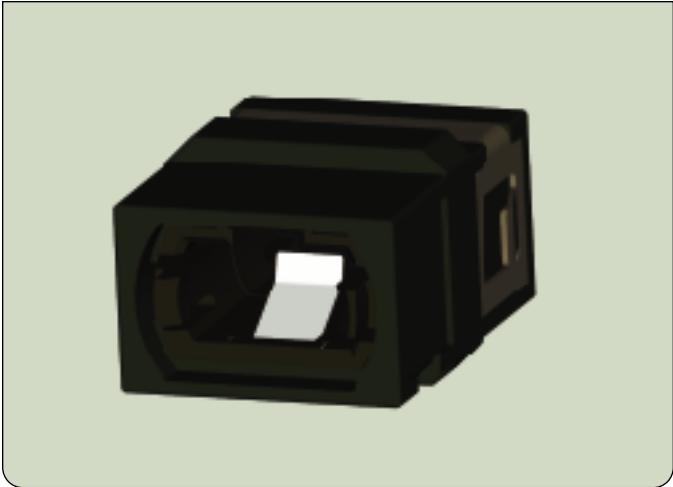

MPO Plastic Adapter

Features

- Available in multiple flange styles to meet various panel design requirements.
- Optional, internal, fully automatic shutter mechanisms on both sides of the adapter to assist in eye safety requirements.
- Shutter requires no manual actuation.
- Flange on die-cast version completely covers panel cutout.
- Meets IEC 1754-7 and TIA/EIA FOCIS 5 standards.
- Accepts industry standard MPO/MTP® interfaces.

MPO Adapter Specifications

Common Specifications

Durability:	< 0.3dB change, 500 mating cycles
Operating Temperature:	-40 to +75°C
Storage Temperature:	-40 to +85°C
Intermateability:	IEC 1754-7 compliant. Meets TIA/EIA FOCIS 5 mating standards. Intermateable with NTT compatible MPO products.

MPO Adapter Ordering Information

MPO Adapters		
Die-cast Adapters		
Part #	Description	Housing Color
955-121-5010	MPO Die-cast adapter, standard flange	metallic
955-121-5110	MPO Die-cast adapter, standard flange, with shutters	metallic
955-121-5020	MPO Die-cast adapter, rotated flange	metallic
955-121-5120	MPO Die-cast adapter, rotated flange, with shutters	metallic
955-121-5030	MPO Die-cast adapter, reduced flange	metallic
955-121-5130	MPO Die-cast adapter, reduced flange, with shutters	metallic



MPO Die-cast Adapter

Plastic Adapters		
Part #	Description	Housing Color
955-120-5010	MPO Adapter, standard flange	black
955-120-5110	MPO Adapter, standard flange, with shutters	black
955-120-5020	MPO Adapter, rotated flange	black
955-120-5120	MPO Adapter, rotated flange, with shutters	black
955-120-5030	MPO Adapter, reduced flange	black
955-120-5130	MPO Adapter, reduced flange, with shutters	black
955-120-5040	MPO Adapter, rotated reduced flange	black
955-120-5140	MPO Adapter, rotated reduced flange, with shutters	black



MPO Plastic Adapter

Ordering Information

LX.5 Connectors				
Part #	Description	Recommended Cable Diameter	Body Color	Boot Color
961-103-5006	LX.5 APC connector, 126µm zirconia ferrule	1.70mm	green	green
961-103-5106	LX.5 APC connector, 126µm zirconia ferrule	2.0mm	green	green
961-103-5206	LX.5 APC connector, 126µm zirconia ferrule	900µm	green	green
961-111-5006	LX.5 singlemode connector, 126µm zirconia ferrule, tunable	1.70mm	blue	blue
961-111-5106	LX.5 singlemode connector, 126µm zirconia ferrule, tunable	2.0mm	blue	blue
961-111-5206	LX.5 singlemode connector, 126µm zirconia ferrule, tunable	900µm	blue	blue
961-101-5007	LX.5 multimode connector, 127µm zirconia ferrule	1.70mm	beige	beige
961-101-5107	LX.5 multimode connector, 127µm zirconia ferrule	2.0mm	beige	beige
961-101-5207	LX.5 multimode connector, 127µm zirconia ferrule	900µm	beige	beige

Accessories	
Part #	Description
961-0001	Duplex clip, singlemode, blue
961-0002	Duplex clip, multimode, beige
961-0003	Duplex clip, APC, green

LX.5 Adapters				
Part #	Description	Alignment Sleeve Material	Flange Type	Housing Color
961-120-5001	LX.5 APC duplex, shuttered adapter	zirconia	screw mount	green
961-120-5002	LX.5 APC duplex, shuttered adapter	zirconia	small flange	green
961-120-5101	LX.5 singlemode duplex, shuttered adapter	zirconia	screw mount	blue
961-120-5102	LX.5 singlemode duplex, shuttered adapter	zirconia	small flange	blue
961-120-5211	LX.5 multimode duplex, shuttered adapter	phosphor bronze	screw mount	beige
961-120-5212	LX.5 multimode duplex, shuttered adapter	phosphor bronze	small flange	beige

LX.5 Mechanical Dimensions

Connector (1.70mm):

961-1XX-5XXX

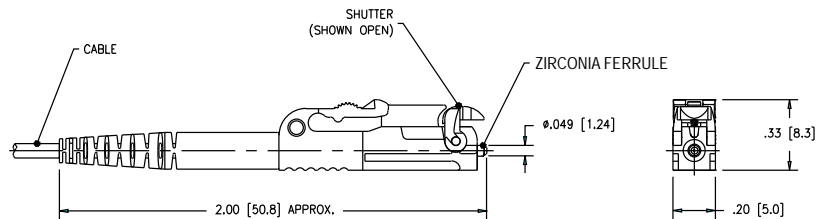

Adapter
(with screw mount flange):

961-120-5XXX

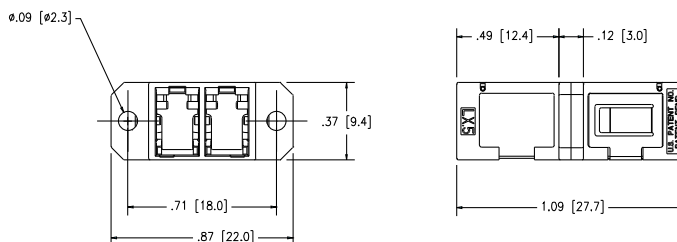

MPO Adapter Line Drawings

MPO Die-cast Adapters

955-121-5X10

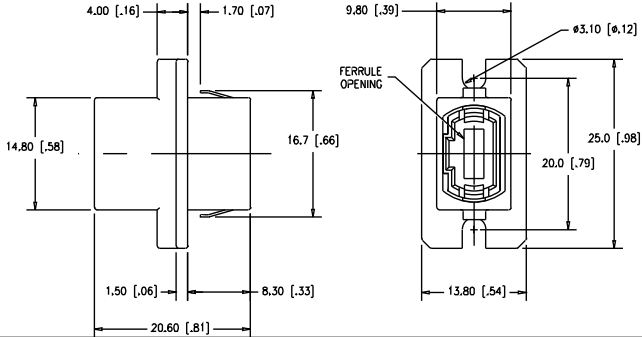

955-121-5X20

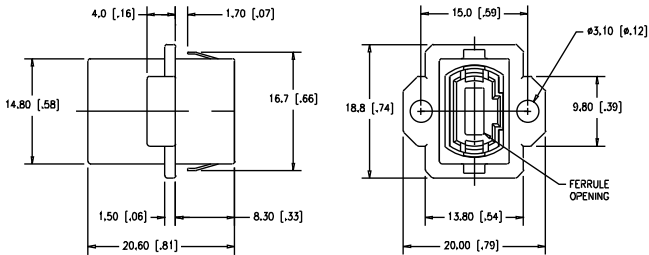

955-121-5X30

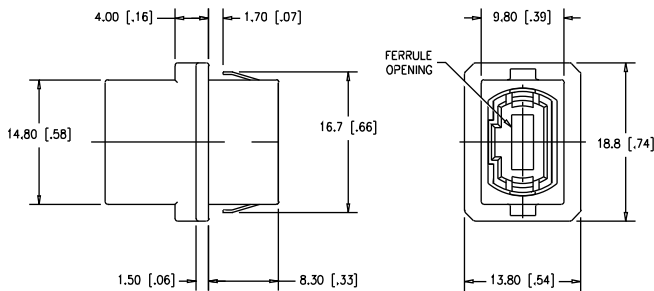

MPO Plastic Adapters

955-120-5X10

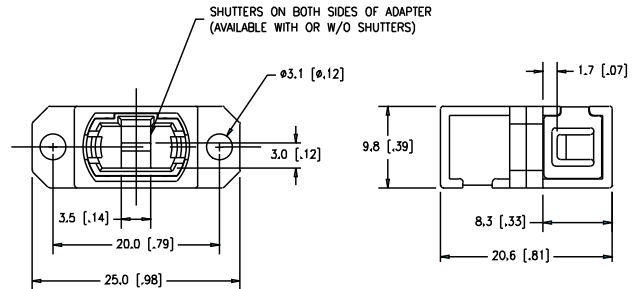

955-120-5X20

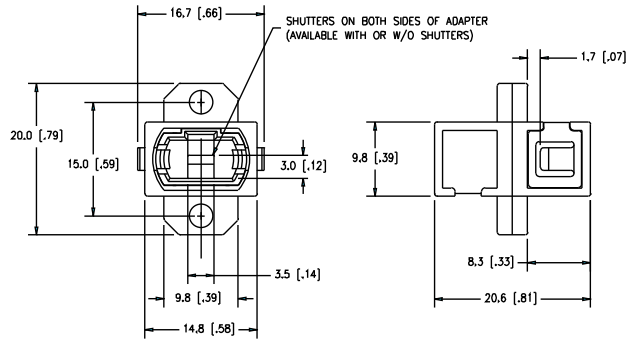

955-120-5X30

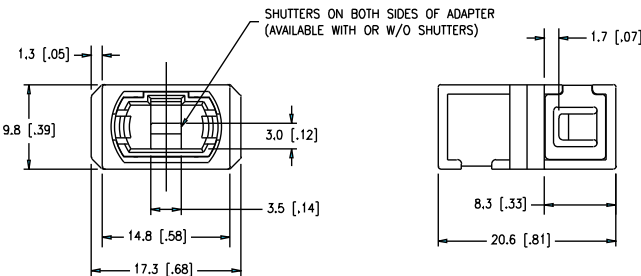

955-120-5X40

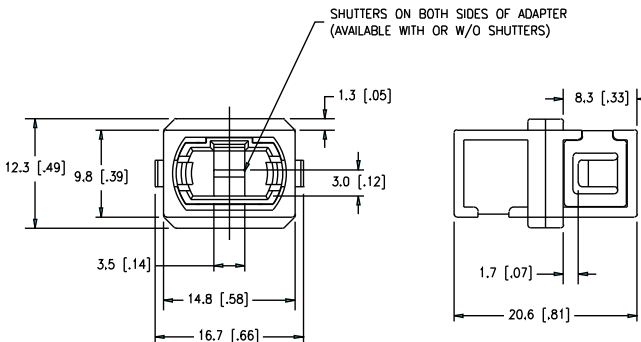

SC Shuttered Adapter

With fiber optics reaching closer to the consumer and the increasingly high-powered active devices being used in today's networking and telecommunication platforms, eye safety is an absolute necessity. Amphenol's SC Shuttered Adapter family has been designed to meet this growing need.

Our new internal shutter solutions for Amphenol's SC adapter designs provide a cost-effective means of blocking stray light. This is accomplished by an integrated, retractable shutter inside the adapter body, which is only actuated by insertion of the SC connector into the adapter. Contact with the ferrule endface and fiber core is avoided due to the stepped design of the shutter, preventing endface damage. A step above other external shutter solutions, Amphenol's design is fully automatic requiring no manual intervention.

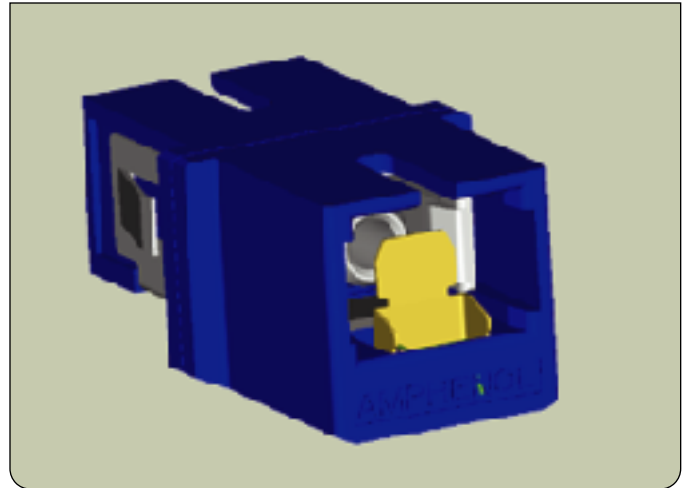

SC Simplex Shuttered Adapter

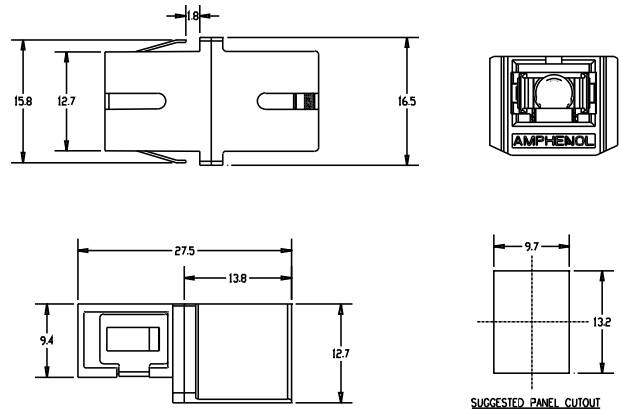

Features

- Eliminates stray laser light during mating and de-mating of the SC connectors to assist in eye safety.
- 100% automatic shutter operation requiring no operator handling of shutter door.
- Simplex and duplex designs (duplex design pending).
- Accommodates industry standard (JIS) panel layouts.
- Plastic meets UL 94V-0 flammability requirements.
- Available with zirconia or phosphor bronze alignment sleeves.
- Screw mount or small flange options available.

Ordering Information

SC Simplex Shuttered Adapters				
Part #	Description	Alignment Sleeve Material	Flange Type	Color
954-120-5600	SC Simplex shuttered adapter, singlemode	zirconia	small flange	blue
954-120-5700	SC Simplex shuttered adapter, APC	zirconia	small flange	green
954-120-5601	SC Simplex shuttered adapter, singlemode	zirconia	screw mount	blue
954-120-5701	SC Simplex shuttered adapter, APC	zirconia	screw mount	green

SC Connectors & Adapters

Amphenol's 954 series fiber optic SC connectors utilize a push-pull retention feature enabling easy insertion and removal, making it ideally suited for high density. The SC connector features an internal cavity that virtually eliminates the possibility of improper epoxy application, thus providing higher manufacturing yields.

Amphenol's SC connectors are exceptionally suited for factory and field installation. Every aspect of the connector system is precision manufactured to produce reliable and consistent performance. The SC is also designed to meet industry specifications for building wiring, EIA/TIA-568A.

Features

- ▶ Unique design automatically gauges correct epoxy dosage, improving yields and reliability.
- ▶ One-piece construction reduces termination time.
- ▶ Non-optical disconnect feature design prevents signal interruption.
- ▶ The highly concentric precision zirconia ferrules are pre-radiused to minimize insertion loss and back reflection.
- ▶ Available in singlemode, APC and multimode versions.
- ▶ Available for 3.0mm and 2.0mm cable with 900um bare fiber boots included.
- ▶ Excellent for factory or field terminations.
- ▶ Duplex version utilizes a flexible coupling sleeve, providing float between channels A and B.
- ▶ Teflon tube in the rear of the connector insures clean epoxy injection.

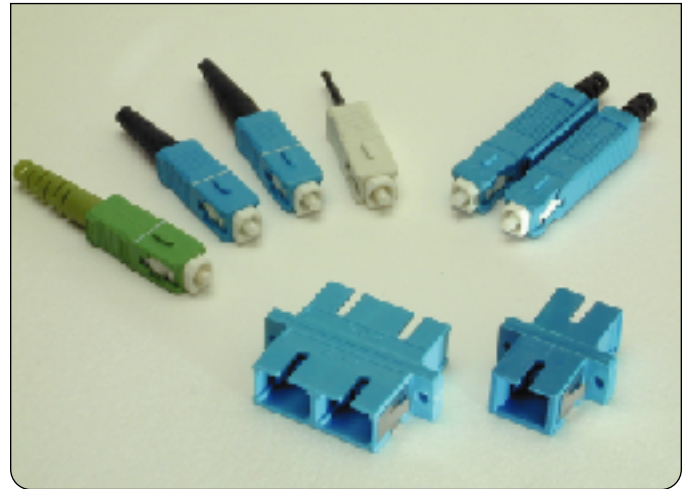

SC Connector & Adapter Family

Common Specifications

Insertion Loss: $\leq 0.15\text{dB}$ typical, singlemode, UPC
 $\leq 0.3\text{dB}$ typical, APC
 $\leq 0.35\text{dB}$ typical, multimode

Return Loss: super (SPC) $\leq -45\text{dB}^*$
ultra (UPC) $\leq -55\text{dB}^*$
angle (APC) $\leq -65\text{dB}^*$

Durability: $< 0.2\text{dB}$ change, 500 mating cycles

Temperature: $< 0.3\text{dB}$ change, -40 to $+85^\circ\text{C}$

Intermateability:

The Amphenol 954 series SC connectors and adapters are mechanically and optically intermateable with NTT SC type products and conform to JIS C 5973. SC duplex connectors and adapters conform to ANSI VX3T9.3 SC specifications and are intermateable.

* Performance is polish dependent.

SC Connector Ordering Information

SC Simplex Connectors				
Part #	Description	Recommended Cable Diameter	Coupling Sleeve Color	Boot Color
954-101-5709	SC Simplex connector, singlemode, 125.5µm zirconia ferrule	3.0mm or 900µm	blue	blue/blue
954-101-5706	SC Simplex connector, singlemode, 126µm zirconia ferrule	3.0mm or 900µm	blue	blue/blue
954-101-5708	SC Simplex connector, multimode, 128µm zirconia ferrule	3.0mm or 900µm	beige	black/black
954-101-5809	SC Simplex connector, singlemode 125.5µm zirconia ferrule	2.0mm or 900µm	blue	blue/blue
954-101-5806	SC Simplex connector, singlemode 126µm zirconia ferrule	2.0mm or 900µm	blue	blue/blue
954-101-5808	SC Simplex connector, multimode, 128µm zirconia ferrule	2.0mm or 900µm	beige	black/black
954-103-5709	SC/APC Simplex connector, singlemode, 125.5µm ferrule	3.0mm or 900µm	green	green/green
954-103-5706	SC/APC Simplex connector, singlemode, 126µm ferrule	3.0mm or 900µm	green	green/green
954-103-5809	SC/APC Simplex connector, singlemode, 125.5µm zirconia ferrule	2.0mm or 900µm	green	green/green
954-103-5806	SC/APC Simplex connector, singlemode, 126µm zirconia ferrule	2.0mm or 900µm	green	green/green

SC Duplex Connectors				
Part #	Description	Recommended Cable Diameter	Coupling Sleeve Color	Boot Color
954-101-5209	SC Duplex connector, singlemode, 125.5µm zirconia ferrule	3.0mm	blue	blue/blue
954-101-5206	SC Duplex connector, singlemode, 126µm zirconia ferrule	3.0mm	blue	blue/blue
954-101-5210	SC Duplex connector, multimode, 128µm zirconia ferrule	3.0mm	beige	black/black
954-101-5220	SC Duplex connector, multimode, 128µm zirconia ferrule	3.0mm	black	black/black

SC Connector Line Drawings

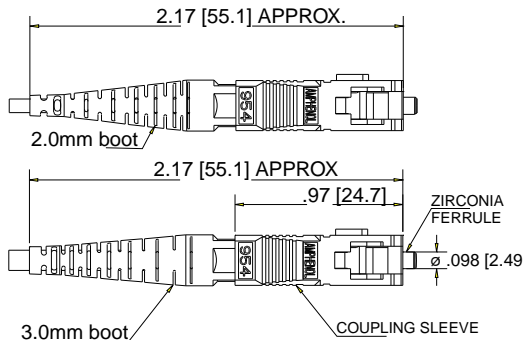

SC simplex connector with 2.0mm & 3.0mm boots

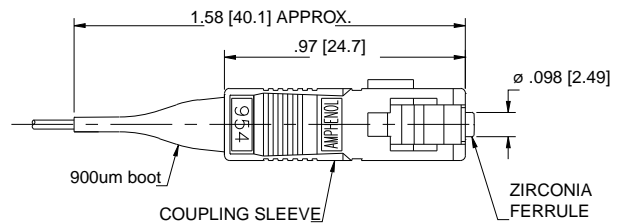

SC simplex connector with 900µm boot

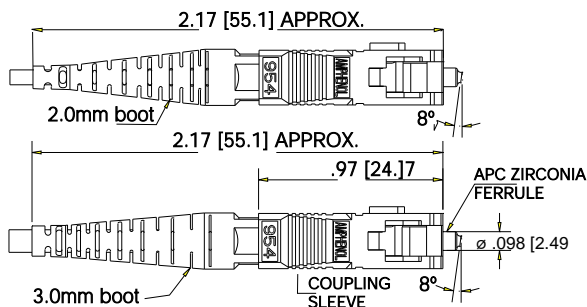

SC/APC simplex connector with 2.0mm & 3.0mm boots

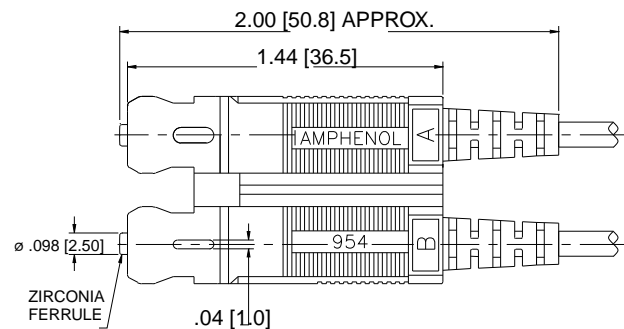

SC duplex connector with 3.0mm boot

SC Simplex Adapter Ordering Information

SC Simplex Adapters				
Part #	Description	Alignment		Color
		Sleeve Material	Flange Type	
954-120-5000	SC Simplex adapter, singlemode	zirconia	screw mount	blue
954-120-5001	SC Simplex adapter, singlemode	phosphor bronze	screw mount	blue
954-120-5109	SC Simplex adapter, APC	zirconia	screw mount	green
954-122-5002	SC Simplex adapter, multimode	phosphor bronze	screw mount	beige
954-122-5001	SC Simplex adapter, multimode	phosphor bronze	screw mount	black
954-120-5108	SC Simplex adapter, singlemode	zirconia	small flange	blue
954-120-5101	SC Simplex adapter, singlemode	phosphor bronze	small flange	blue
954-120-5111	SC Simplex adapter, APC	zirconia	small flange	green
954-122-5102	SC Simplex adapter, multimode	phosphor bronze	small flange	beige
954-122-5110	SC Simplex adapter, multimode	phosphor bronze	small flange	black

SC Simplex Hybrid Adapters				
Part #	Description	Alignment		Color
		Sleeve Material	Flange Type	
954-944-5001	SC-FC Hybrid simplex adapter, singlemode	zirconia	screw mount	metallic
954-944-5000	SC-FC Hybrid simplex adapter, multimode	phosphor bronze	screw mount	metallic
954-953-5000	SC-ST Hybrid simplex adapter, singlemode	zirconia	screw mount	blue/black
954-953-5001	SC-ST Hybrid simplex adapter, singlemode	phosphor bronze	screw mount	blue/black

SC Duplex Adapter Ordering Information

SC Duplex Adapters				
Part #	Description	Alignment		Housing
		Sleeve Material	Flange Type	Color
954-120-5200	SC Duplex adapter, singlemode	zirconia	screw mount	blue
954-122-5201	SC Duplex adapter, singlemode	phosphor bronze	screw mount	blue
954-120-5209	SC Duplex adapter, APC	zirconia	screw mount	green
954-122-5210	SC Duplex adapter, multimode	phosphor bronze	screw mount	beige
954-122-5211	SC Duplex adapter, multimode	phosphor bronze	screw mount	black
954-120-5400	SC Duplex adapter, singlemode	zirconia	small flange	blue
954-120-5401	SC Duplex adapter, singlemode	phosphor bronze	small flange	blue
954-120-5409	SC Duplex adapter, singlemode	zirconia	small flange	green
954-122-5410	SC Duplex adapter, multimode	phosphor bronze	small flange	beige
954-122-5411	SC Duplex adapter, multimode	phosphor bronze	small flange	black

SC Hybrid Adapters				
Part #	Description	Alignment		Housing
		Sleeve Material	Flange Type	Color
954-953-5200	SC-ST Hybrid duplex adapter, singlemode	zirconia	screw mount	blue
954-953-5201	SC-ST Hybrid duplex adapter, singlemode	phosphor bronze	screw mount	blue
954-953-5202	SC-ST Hybrid duplex adapter, singlemode	zirconia	screw mount	black
954-953-5210	SC-ST Hybrid duplex adapter, multimode	phosphor bronze	screw mount	beige

SC Adapter Line Drawings

SC simplex adapter with flange

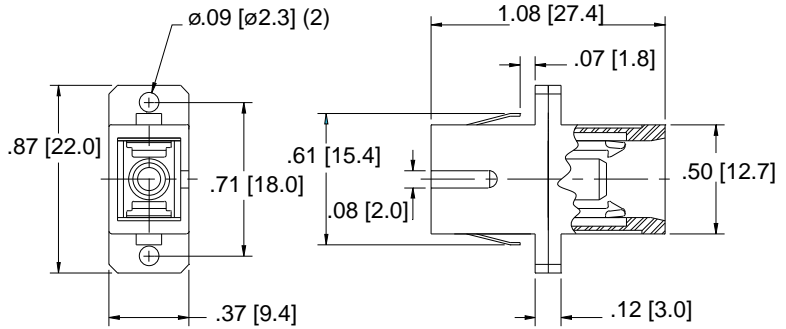

SC duplex adapter with flange

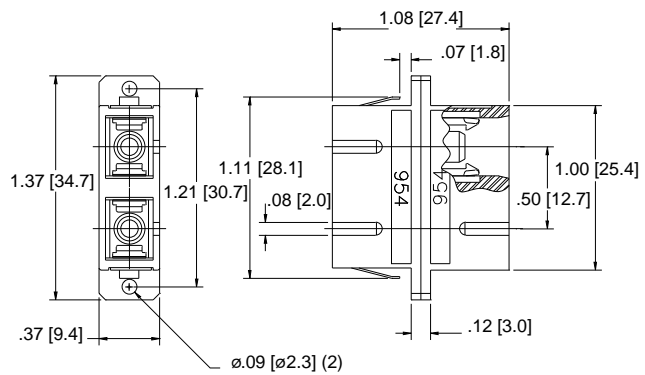

SC simplex adapter with reduced flange

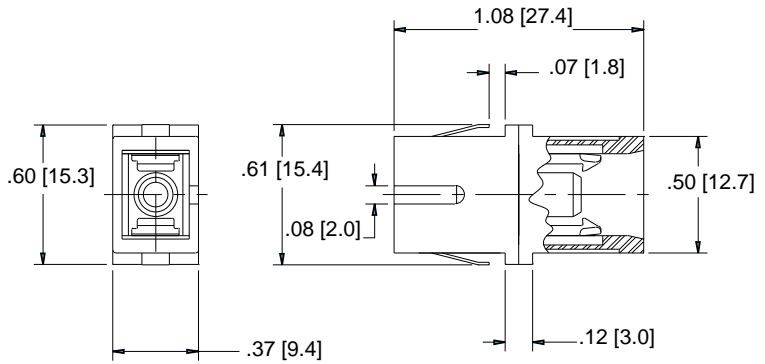

SC duplex adapter with reduced flange

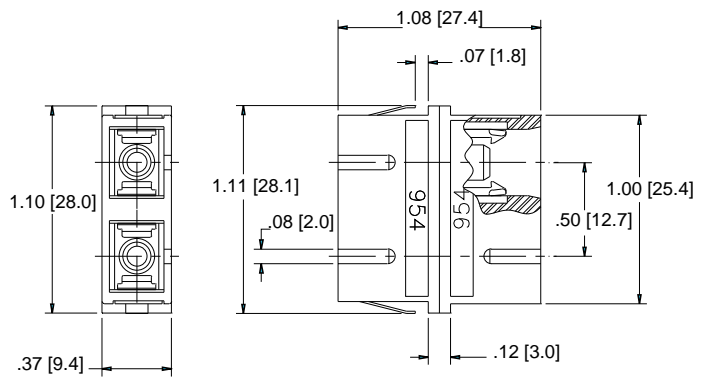

FC Connectors and Adapters

Amphenol's 944 series fiber optic FC connectors effectively terminate optical fiber in a variety of network applications. The connectors are secured using a threaded coupling nut, providing a significant increase in pull-out performance. The FC connectors also feature an internal cavity that virtually eliminates the possibility of improper epoxy application, thus providing higher manufacturing yields.

Amphenol's FC connectors are exceptionally suited for factory and field installation. Every aspect of the connector system is precision manufactured to produce reliable and consistent performance. The 944 series is available in tunable or non-tunable PC versions for flexibility in specific performance requirements.

The FC/APC versions are also tunable as a standard product to provide the maximum performance in singlemode applications. The FC/APC connector system features a tight-fit keyway that prohibits the possible mis-mating between FC/PC and FC/APC connectors.

Features

- ▶ Unique design automatically gauges correct epoxy dosage, improving yields and reliability.
- ▶ One-piece construction reduces termination time.
- ▶ Available in singlemode tunable PC and standard APC tunable versions.
- ▶ Non-optical disconnect design prevents transmission interruption.
- ▶ High precision zirconia ferrules minimize insertion loss and return loss values.
- ▶ Available in singlemode and multimode versions.
- ▶ Adapters are available with high precision zirconia or phosphor bronze alignment sleeves.

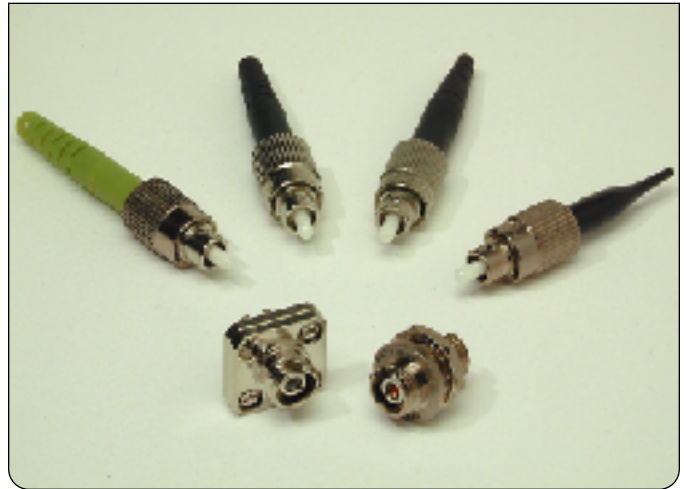

FC Connector & Adapter Family

Common Specifications

Insertion Loss: $\leq 0.15\text{dB}$ typical, singlemode, UPC
 $\leq 0.3\text{dB}$ typical, APC
 $\leq 0.35\text{dB}$ typical, multimode

Return Loss: super (SPC) $\leq -45\text{dB}^*$
ultra (UPC) $\leq -55\text{dB}^*$
angle (APC) $\leq -65\text{dB}^*$

Durability: $< 0.2\text{dB}$ change, 500 mating cycles

Temperature: $< 0.3\text{dB}$ change, -40 to $+85^\circ\text{C}$

Intermateability:

The Amphenol 944 series FC connectors and adapters are mechanically and optically intermateable with NTT FC type products and conform to JIS C 5970.

* Performance is polish dependent.

FC Connector Part Numbers

FC Connectors				
Part #	Description	Recommended Cable Diameter	Body Color	Boot Color
944-601-5709	FC Connector, singlemode, plastic body, metal nut, 125.5µm zirconia ferrule	3.0mm or 900µm	natural	black/black
944-601-5706	FC Connector, singlemode, plastic body, metal nut, 126µm zirconia ferrule	3.0mm or 900µm	natural	black/black
944-601-5708	FC Connector, multimode, plastic body, metal nut, 128µm zirconia ferrule	3.0mm or 900µm	natural	black/black
944-601-5809	FC Connector, singlemode, plastic body, metal nut, 125.5µm zirconia ferrule	2.0mm or 900µm	natural	black/black
944-601-5806	FC Connector, singlemode, plastic body, metal nut, 126µm zirconia ferrule	2.0mm or 900µm	natural	black/black
944-601-5808	FC Connector, multimode, plastic body, metal nut, 128µm zirconia ferrule	2.0mm or 900µm	natural	black/black
944-603-5709*	FC APC Tunable connector, singlemode, plastic body, metal nut, 125.5µm zirconia ferrule	3.0mm or 900µm	natural	green/green
944-603-5706*	FC APC Tunable connector, singlemode, plastic body, metal nut, 126µm zirconia ferrule	3.0mm or 900µm	natural	green/green
944-603-5809*	FC APC Tunable connector, singlemode, plastic body, metal nut, 125.5µm zirconia ferrule	2.0mm or 900µm	natural	green/green
944-603-5806*	FC APC Tunable connector, singlemode, plastic body, metal nut, 126µm zirconia ferrule	2.0mm or 900µm	natural	green/green
944-611-5709*	FC Tunable connector, singlemode, plastic body, metal nut, 125.5µm zirconia ferrule	3.0mm or 900µm	natural	black/black
944-611-5706*	FC Tunable connector, singlemode, plastic body, metal nut, 126µm zirconia ferrule	3.0mm or 900µm	natural	black/black
944-611-5809*	FC Tunable connector, singlemode, plastic body, metal nut, 125.5µm zirconia ferrule	2.0mm or 900µm	natural	black/black
944-611-5806*	FC Tunable connector, singlemode, plastic body, metal nut, 126µm zirconia ferrule	2.0mm or 900µm	natural	black/black

*Each FC Tunable connector comes with Amphenol FC Tuning Key 944-611-1001

FC Adapter Part Numbers

FC Adapters				
Part #	Description	Alignment Sleeve Material	Flange Type	Color
944-120-6000	FC Adapter, metal body, singlemode	zirconia	square, screw mount	metallic
944-120-6001	FC Adapter, metal body, multimode	phosphor bronze	square, screw mount	metallic
944-125-6003	FC Adapter, metal body, singlemode, D-hole type	zirconia	feed-through, D-hole	metallic
944-125-6002	FC Adapter, metal body, multimode, D-hole type	phosphor bronze	feed-through, D-hole	metallic
944-125-6004	FC APC Adapter, metal body, singlemode, D-hole type	zirconia	feed-through, D-hole	metallic
944-125-6005	FC APC Adapter, metal body, multimode, D-hole type	phosphor bronze	feed-through, D-hole	metallic

Hybrid FC Adapters				
Part #	Description	Alignment Sleeve Material	Flange Type	Color
954-944-5001	SC-FC Hybrid simplex adapter, singlemode	zirconia	square, screw mount	metallic
954-944-5000	SC-FC Hybrid simplex adapter, multimode	phosphor bronze	square, screw mount	metallic

FC Connector Line Drawings

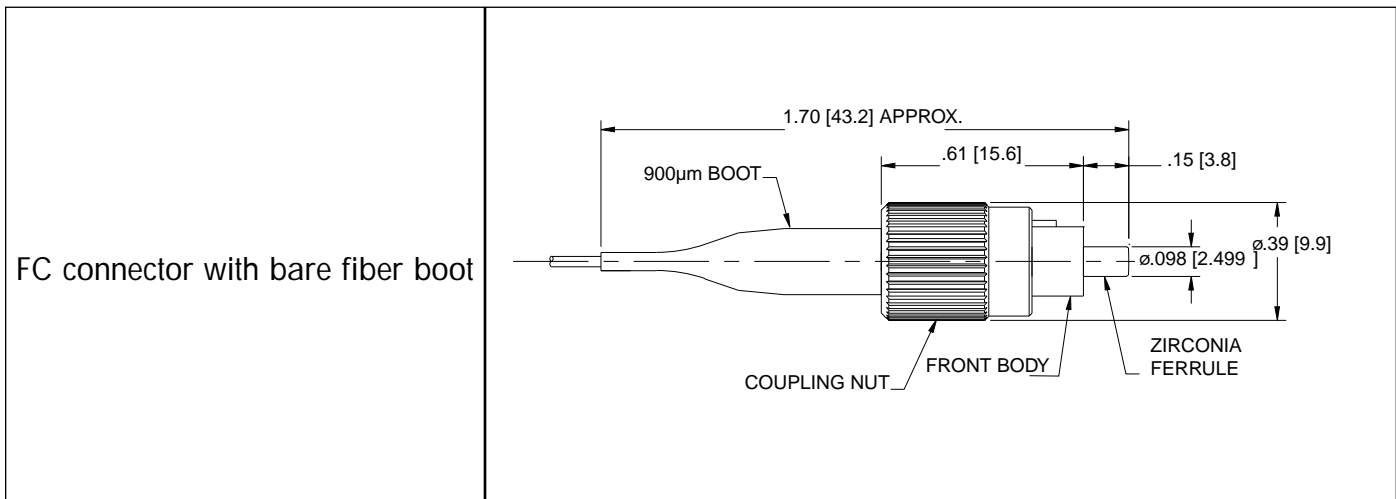
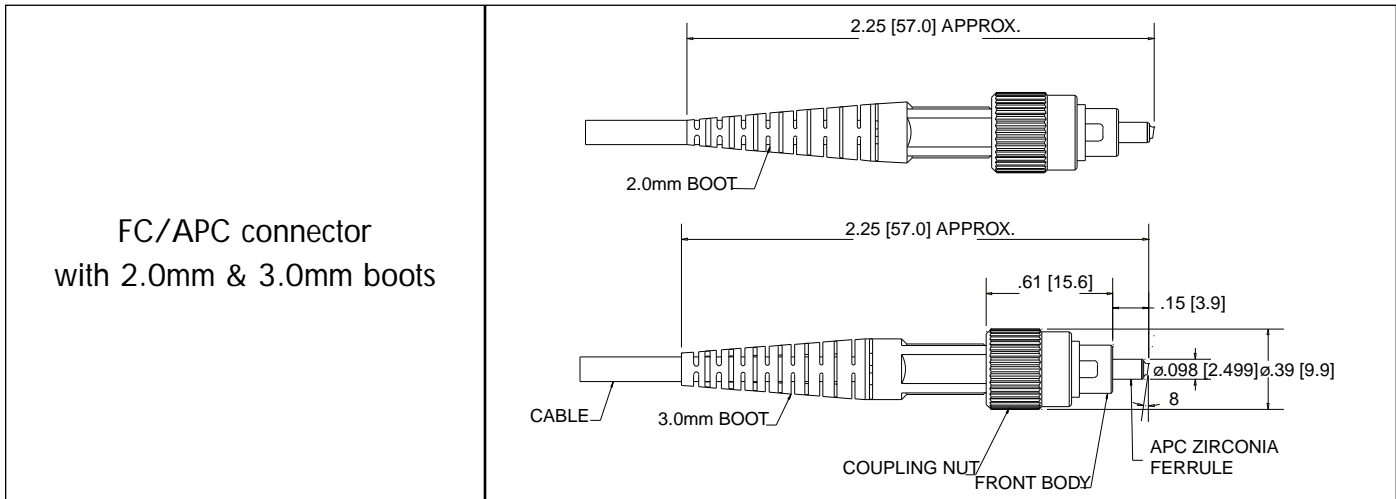
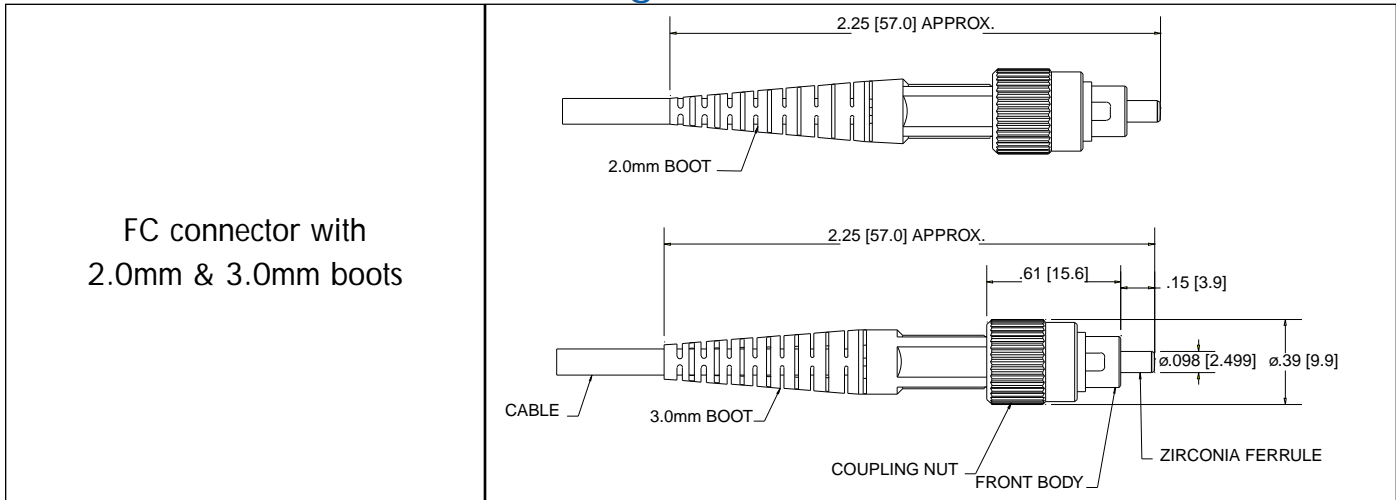

FC Adapter Line Drawings

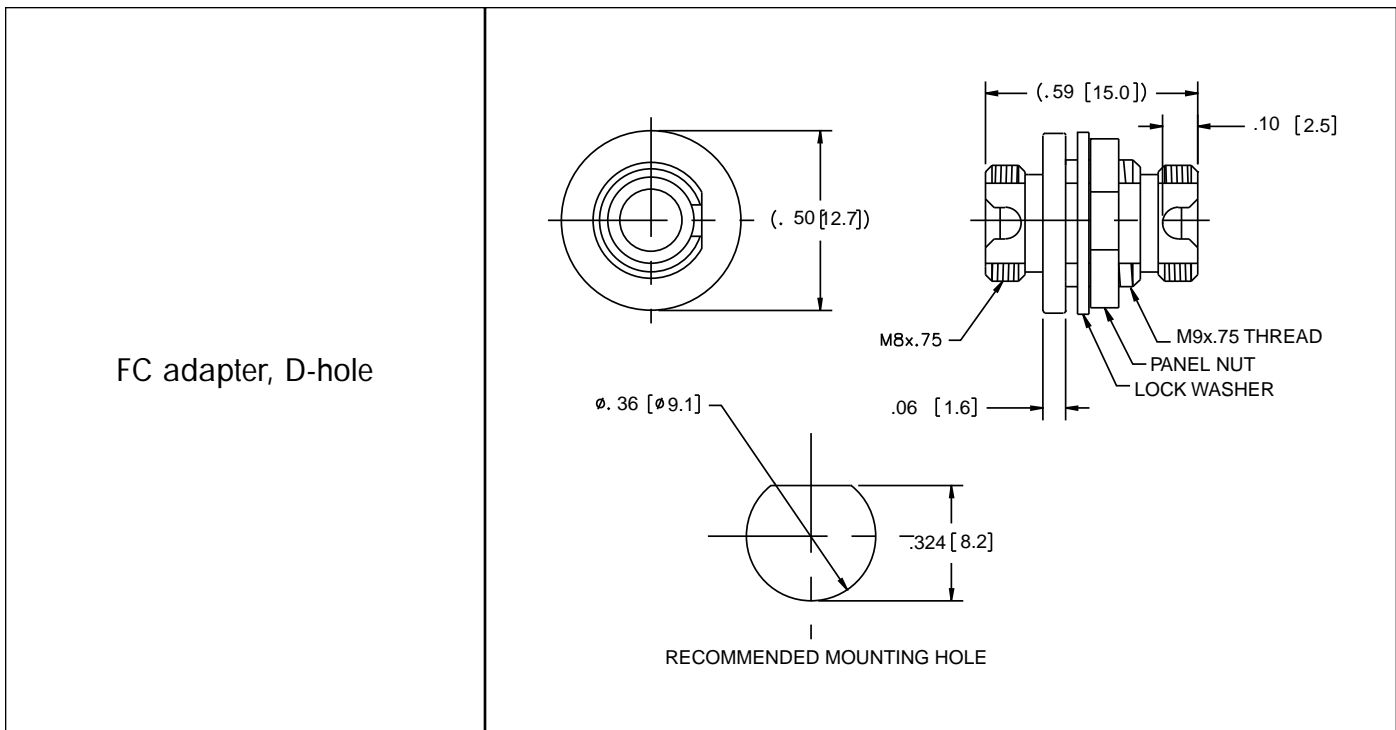
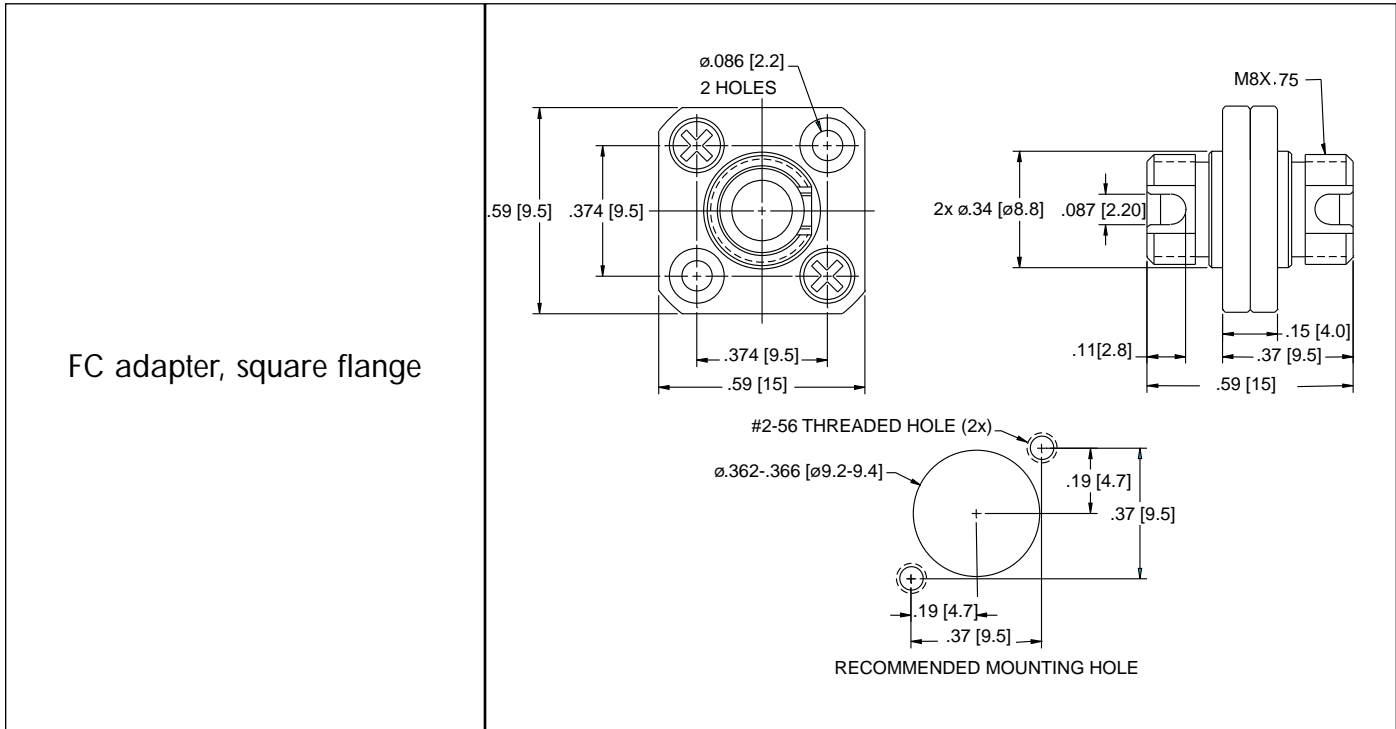

LC Connectors & Adapters

Amphenol's 956 series fiber optic LC connectors utilize the familiar RJ-45 style latching mechanism. As a small form factor (SFF) connector, the LC connector is almost half the size of the popular SC connector. With accelerated growth demanding greater bandwidth in less physical space, LC connectors have emerged as a viable solution for high density frames and patch panels.

Amphenol's LC connectors have many of the traditional performance advantages of standard connectors, but with a smaller package.

Features

- Time-tested zirconia ferrule (1.25mm).
- Increased density compared to standard connectors.
- Standard simplex and duplex styles.
- Color coding (singlemode: blue, multimode: beige) per TIA 568.A.
- Familiar RJ-45 latching style.
- Exceptional for factory termination.

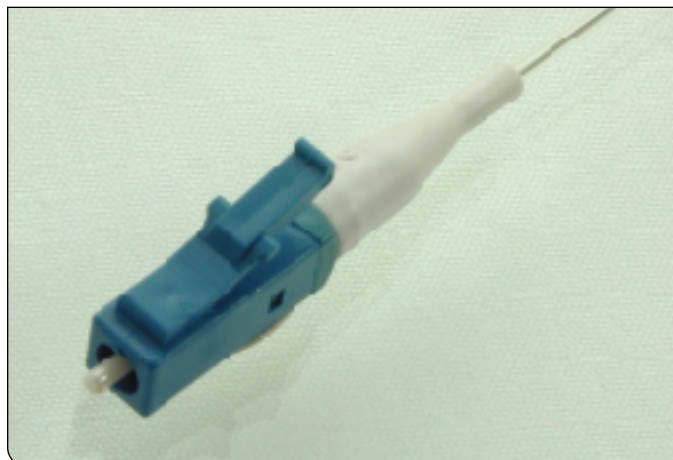

LC Connector & Adapter Family

Common Specifications

Insertion Loss: $\leq 0.15\text{dB}$ typical, singlemode, UPC (untuned)
 $\leq 0.25\text{dB}$ typical, multimode

Return Loss: super (SPC) $\leq -45\text{dB}^*$
 ultra (UPC) $\leq -55\text{dB}^*$

Durability: $< 0.2\text{dB}$ change, 500 mating cycles

Temperature: $< 0.3\text{dB}$ change, -40 to $+85^\circ\text{C}$

Intermateability:

The Amphenol 956 series LC connector is Telcordia, EIA, IEC compliant. Polarized per TIA 568-A, color coded per TIA-568-A, and intermateable with industry standard LC connectors and adapters.

* Performance is polish dependent.

LC Connector Part Numbers

LC Connectors		Recommended Cable Diameter	Body Color	Boot Color
Part #	Description			
956-101-5006	LC Simplex connector, singlemode, 126µm zirconia ferrule	2.0/1.60mm	blue	white
956-101-5005	LC Simplex connector, singlemode, 126µm zirconia ferrule	900µm	blue	white
956-102-5006	LC Simplex connector, multimode, 127µm zirconia ferrule	2.0/1.60mm	beige	white
956-102-5005	LC Simplex connector, multimode, 127µm zirconia ferrule	900µm	beige	white
956-101-5206	LC Duplex connector, singlemode, 126µm zirconia ferrule	2.0/1.60mm	blue	white
956-102-5206	LC Duplex connector, multimode, 127µm zirconia ferrule	2.0/1.60mm	beige	white
LC Adapters				
Part #	Description	Color		
956-120-5000	LC Simplex adapter, singlemode, zirconia alignment sleeve, molded panel latches	blue		
956-122-5000	LC Simplex adapter, singlemode, phosphor bronze alignment sleeve, molded panel latches	beige		
956-120-5200	LC Duplex adapter, singlemode, zirconia alignment sleeve, molded panel latches	blue		
956-122-5200	LC Duplex adapter, singlemode, phosphor bronze alignment sleeve, molded panel latches	beige		

LC Line Drawings

LC simplex connector with 2.0 / 1.60mm boot

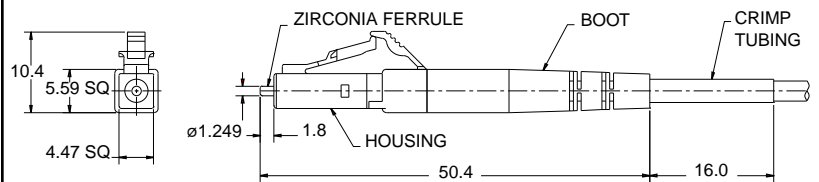

LC simplex connector with bare fiber boot

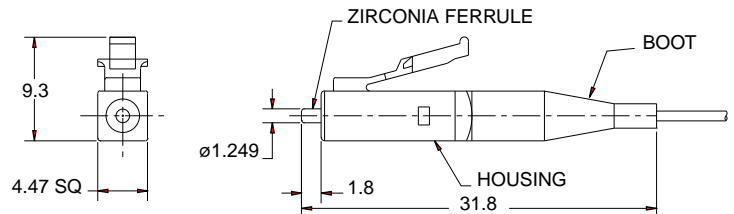

LC duplex adapter

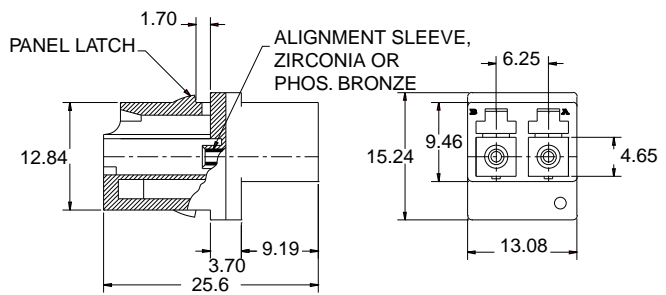

LC simplex adapter

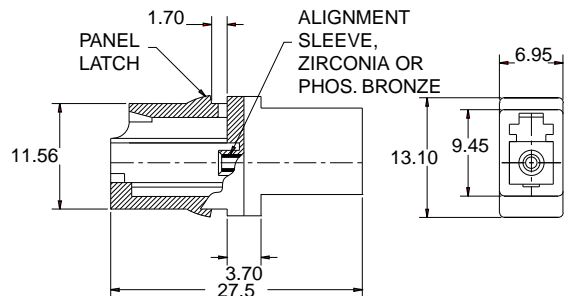

ST Connectors and Adapters

Amphenol's 953 series fiber optic ST and ST II connectors utilize a bayonet style mating concept to provide a secure, robust coupling mechanism. The enclosed spiral slotted coupling nut allows easy insertion in densely packed patch panels. The ST connector has been used extensively in telecom, data and premise installation applications and could easily be considered a de facto standard. The ST's mass installation base will maintain its prominence for years to come.

Amphenol's ST compatible connectors are exceptionally suited for factory and field installations. Special attention has been given to every ST performance parameter, increasing product repeatability and exceeding industry standards. All ST products are compatible with the AT&T, ST and ST II product series.

Features

- The ST connector body and coupling nut are precision molded with a flame retardant, glass-filled polymer for a durable and light weight product.
- The ST II connector body and coupling nut are precision zinc die-cast and nickel plated for superior strength and corrosion resistance.
- Available with highly concentric precision zirconia ferrules pre-radiused to minimize insertion loss and back reflection.
- The connectors utilize a crimp-on cable retention system for ease of termination and superior load carrying ability.
- Adapters are available with zirconia or phosphor bronze alignment sleeves.

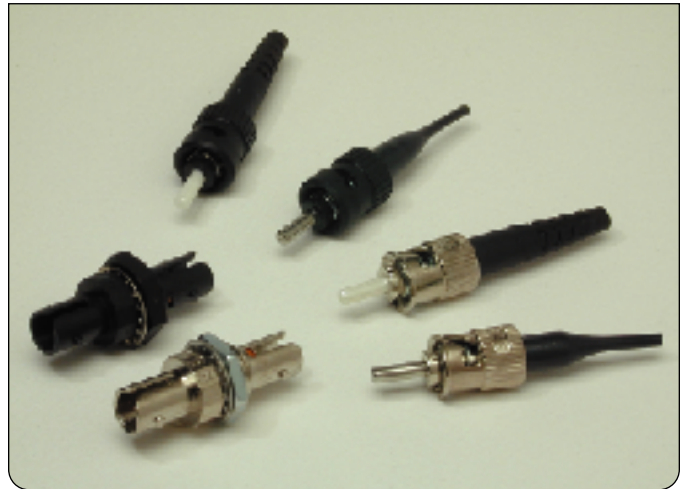

ST Connector & Adapter Family

Common Specifications

Insertion Loss: $\leq 0.15\text{dB}$ typical, singlemode, UPC
 $\leq 0.35\text{dB}$ typical, multimode

Return Loss: super (SPC) $\leq -45\text{dB}^*$
ultra (UPC) $\leq -55\text{dB}^*$

Durability: $< 0.2\text{dB}$ change, 500 mating cycles

Temperature: $< 0.3\text{dB}$ change, -40 to $+85^\circ\text{C}$

Intermateability:

The Amphenol 953 series ST connectors and adapters are optically and mechanically compatible with AT&T/Lucent Technologies ST and ST II connectors and their functional equivalents.

* Performance is polish dependent.

ST Connector Part Numbers

STII Connectors					
Part #	Description	Recommended Cable Diameter	Body and Nut Material	Body Color	Boot Color
953-101-5306	STII Connector , singlemode, 126µm zirconia ferrule	3.0mm or 900µm	die-cast	metallic	black
953-101-5310	STII Connector , multimode, 128µm zirconia ferrule	3.0mm or 900µm	die-cast	metallic	black
953-102-5301	STII Connector, multimode, 128µm stainless steel ferrule	3.0mm or 900µm	die-cast	metallic	black
953-102-5302	STII Connector, multimode, 144µm stainless steel ferrule	3.0mm or 900µm	die-cast	metallic	black
953-102-5303	STII Connector, multimode, 231µm stainless steel ferrule	3.0mm or 900µm	die-cast	metallic	black

*-STII Stainless steel ferrules are available in custom drill-out sizes. Contact Customer Service for additional information.

ST Connectors					
Part #	Description	Recommended Cable Diameter	Body and Nut Material	Body Color	Boot Colors
953-101-5006	ST Connector, singlemode, 126µm zirconia ferrule	3.0mm or 900µm	plastic	yellow	black
953-101-5010	ST Connector, multimode, 128µm zirconia ferrule	3.0mm or 900µm	plastic	black	black
953-102-5001	ST Connector, multimode, 128µm stainless steel ferrule	3.0mm or 900µm	plastic	black	black
953-102-5002	ST Connector, multimode, 144µm stainless steel ferrule	3.0mm or 900µm	plastic	gray	black
953-102-5003	ST Connector, multimode, 231µm stainless steel ferrule	3.0mm or 900µm	plastic	blue	black

*-ST Stainless steel ferrules are available in custom drill-out sizes. Contact Customer Service for additional information.

ST Adapter Part Numbers

ST Adapters				
Part #	Description	Alignment Sleeve Material	Flange Type	Color
953-120-5000	ST Bulkhead, singlemode adapter, polymer body, D-Hole type	zirconia	feed-through, D-Hole	black
953-120-5003	ST Bulkhead, singlemode adapter, die-cast body, D-Hole type	zirconia	feed-through, D-Hole	metallic
953-122-5002	ST Bulkhead, multimode adapter, polymer body, D-Hole type	phosphor bronze	feed-through, D-Hole	beige
953-122-5003	ST Bulkhead, multimode adapter, die-cast body, D-Hole type	phosphor bronze	feed-through, D-Hole	metallic
954-953-5000	SC-ST Hybrid simplex adapter, singlemode	zirconia	screw mount	blue/black
954-953-5001	SC-ST Hybrid simplex adapter, multimode	phosphor bronze	screw mount	blue/black

Accessories	
953-1061	ST Dust cap with chain

ST Connector Line Drawings

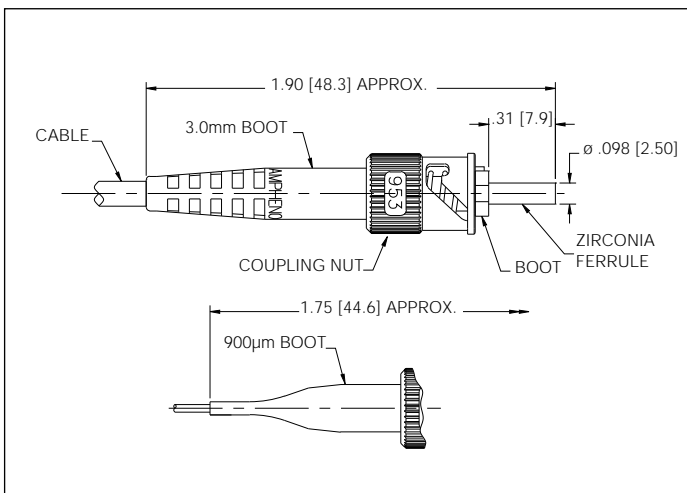

ST II connector with 3.0mm
& bare fiber boot

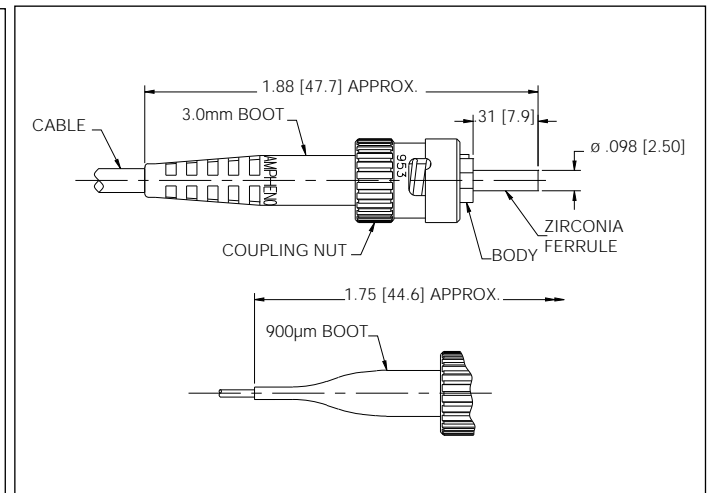

ST connector with 3.0mm
& bare fiber boot

SMA Connectors, Adapters & Receptacles

Amphenol Fiber Optics was a pioneer in developing the first industry standard fiber optic interconnect system by introducing the SMA connector. The 905 and 906 series were the first fiber optic interconnect system to gain industry wide acceptance for military, industrial, data communications and medical applications. Today, Amphenol Fiber Optics continues to support these markets with a wide variety of products that meet the continuing need for the family of SMA's.

The SMA connector family utilizes a threaded coupling nut system for mating and de-mating. Available with zirconia or stainless steel ferrules with custom hole sizes, the SMA is an excellent choice for a robust, low-cost and reliable system.

Amphenol's long standing history and development of the SMA product insures exceptional quality and long term reliability. We continue to support further development and improvement with our standard and custom product offering.

Features

- Reliable, robust and time-tested as one of the first industry standard fiber optic interfaces.
- Threaded, metal coupling nut for maximum retention.
- Stainless steel ferrules available in custom, precision drilled fiber holes for specialized applications.
- Available with hexagonal coupling nut upon request.



SMA Connectors

Common Specifications

Insertion Loss: 128µm & 144µm SMARt ferrule (zirconia, 905 series):
 $\leq 0.8\text{dB}$ typical

128µm & 144µm stainless steel ferrule:
 $\leq 2.0\text{dB}$ typical

Tolerances for custom, micro-drilled holes for stainless steel ferrules:

Fiber Hole Size	Tolerance
128 & 144µm	+5/-0µm
145 to 200µm	+10/-0µm
201 to 500µm	+5%/-0µm
500µm and higher	+25/-0µm

SMA Connector Part Numbers

SMA Connectors		
Part #	Description	Boot Color
905-400-5007	SMARt Connector, multimode, 144µm zirconia ferrule, round metal coupling nut	black
905-405-5007	SMARt Connector, multimode, 128µm zirconia ferrule, round metal coupling nut	black
905-150-5001	SMA Connector, multimode, 128µm stainless steel ferrule, round metal coupling nut	black
905-150-5002	SMA Connector, multimode, 144µm stainless steel ferrule, round metal coupling nut	black
905-150-5003	SMA Connector, multimode, 231µm stainless steel ferrule, round metal coupling nut	black

*-SMA 905 Series stainless steel ferrules are available in custom drill-out sizes. Contact Customer Service for additional information.

Part #	Description	Boot Color
906-150-5001	SMA Connector, multimode, stepped 128µm stainless steel ferrule, round metal coupling nut	black
905-150-5002	SMA Connector, multimode, stepped 144µm stainless steel ferrule, round metal coupling nut	black
905-150-5003	SMA Connector, multimode, stepped 231µm stainless steel ferrule, round metal coupling nut	black

*-SMA 906 Series stainless steel ferrules are available in custom drill-out sizes. Contact Customer Service for additional information.

**-SMA 906 Series packaged with half and full length alignment sleeves.

SMA Adapter & Receptacle Part Numbers

SMA Adapters	
Part #	Description
905-120-5000	SMA Adapter for 905/906 series, bulkhead feed-through type, D-hole mount, jack-jack, nut and washer
905-120-5003	SMA Adapter for 905/906 series, in-line type, jack-jack, 2 nuts and 2 washers
905-120-5004	SMA Adapter for 905/906 series, half-length type, nut and washer
905-120-5008	SMA Adapter for 905/906 series, environmentally-sealed, bulkhead feed-through type, D-hole mount, jack-jack, nut and washer
905-120-5016	SMA Adapter for 905/906 series, bulkhead feed-through type, D-hole mount, jack-jack, nut and washer

SMA Receptacles	
Part #	Description
905-117-5000	905/906 SMA Receptacle, flange mount type, TO-5 can or insert
905-118-5000	905/906 SMA Receptacle, planar screw mount type, TO-5 can or insert
905-138-5001	905/906 SMA Receptacle, planar screw mount type, TO-18, TO-46 or SE 4352 can, keyway, can alignment sleeve
905-138-5002	905/906 SMA Receptacle, screw mount/bulkhead mount type, TO-18, TO-46 or SE 4352 can, keyway, nut and lock washer, can alignment sleeve
905-145-5000	905/906 SMA Receptacle, bulkhead mount type, TO-18, TO-46 or SE 4352 can, keyway, nut and lock washer, can alignment sleeve

Accessories	
Part #	Description
905-163	Dust cap with chain for 905/906 series connectors and adapters
906-101-3002	Half-length alignment sleeve, mates 906 to active device receptacle or converts 906 series to 905 series connectors
906-101-3003	Full length alignment sleeve, preferential hold, mates 906 series to 906 series connectors

SMA Connector Line Drawings

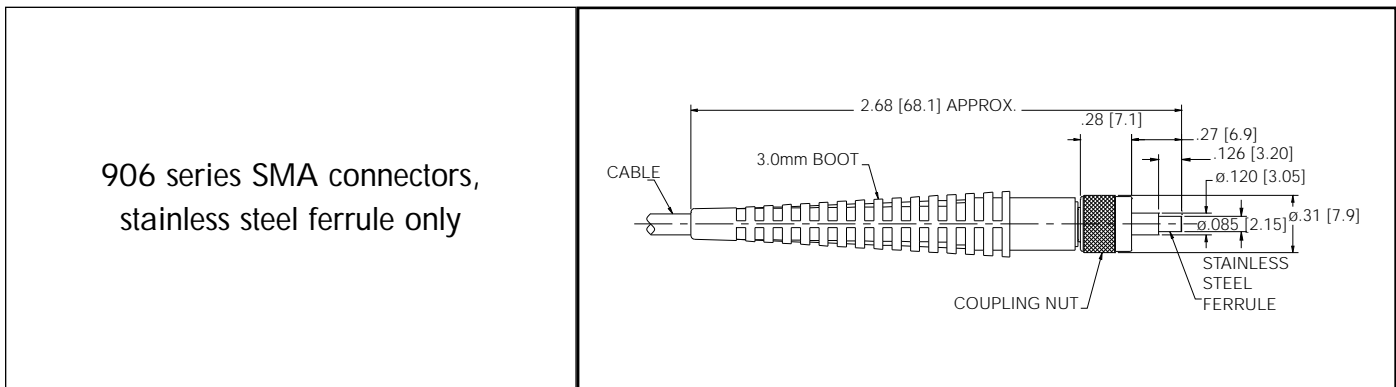
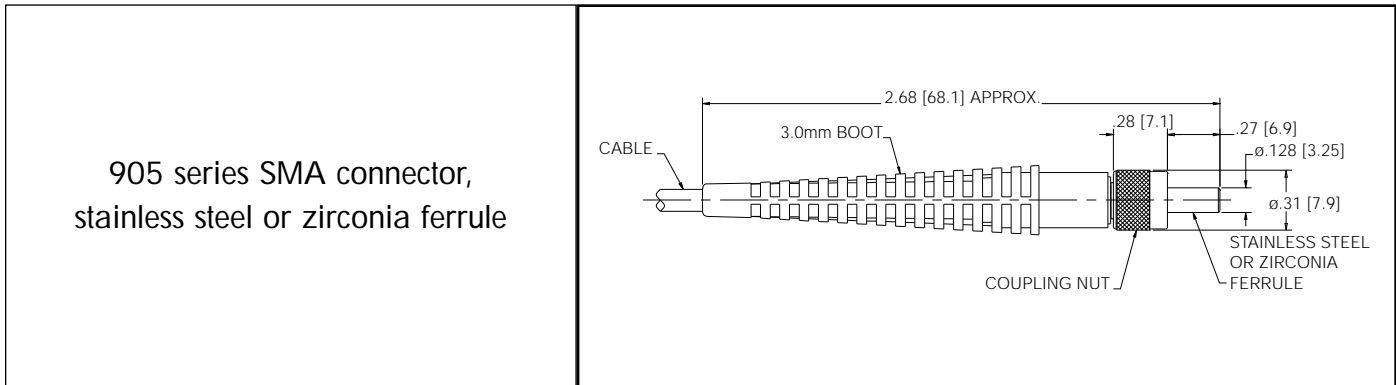

SMA Adapters & Receptacles

<p>905-120-5000</p> <ul style="list-style-type: none"> *905/906 adapter *bulkhead feed-thru *D-hole *jack to jack *nut and washer 		<p>905-118-5000</p> <ul style="list-style-type: none"> *905/906 receptacle *planar screw mount *TO-5 can or insert 	
<p>905-120-5003</p> <ul style="list-style-type: none"> *905/906 adapter *in-line *jack to jack *2 nuts and 2 washers 		<p>905-138-5001</p> <ul style="list-style-type: none"> *905/906 receptacle *planar screw mount *TO-18 & TO-46 *SE 4352 can *keyway *can alignment sleeve 	
<p>905-120-5004</p> <ul style="list-style-type: none"> *905/906 adapter *half-length *nut and washer 		<p>905-138-5002</p> <ul style="list-style-type: none"> *905/906 receptacle *screw mount/bulkhead *TO-18, TO-46 or SE 435 *keyway *can alignment sleeve *nut and washer 	
<p>905-120-5008</p> <ul style="list-style-type: none"> *905/906 adapter *environmentally sealed *bulkhead feed-thru *D-hole *jack to jack *nut and washer 		<p>905-145-5000</p> <ul style="list-style-type: none"> *905/906 receptacle *bulkhead mount *TO-18& TO-46 *keyway *nut/lock washer *SE 4352 can *can alignment sleeve 	
<p>905-120-5016</p> <ul style="list-style-type: none"> *905/906 adapter *bulkhead feed-thru *D-hole *jack to jack *nut and washer 		<p>905-163</p> <ul style="list-style-type: none"> *dustcap w/chain *for 905/906 connectors and adapters 	
<p>905-117-5000</p> <ul style="list-style-type: none"> *905/906 receptacle *flange mount *TO-5 can or insert 			

Amphenol Corporation Website

www.amphenol.com

Worldwide Service & Support

AMERICAS

Amphenol Corporation

Wallingford, CT, U.S.A.
Phone: +1-203-265-8900
E-mail: aphinfo@amphenol.com

Amphenol Canada Corp.

Scarborough, Ontario, Canada
Phone: +1-416-291-4401
E-mail: mattl@amphenolcanada.com

Amphenol Interconnect Products Corporation

Endicott, NY, U.S.A.
Phone: +1-607-754-4444
E-mail: sales@aipc.fabrik.com

Amphenol Spectra-Strip Operations

Hamden, CT, U.S.A.
Phone: +1-203-281-3200
Email: sales@spectra-strip.com

Amphenol RF Division

Danbury, CT., U.S.A.
Phone: 1-203-796-2000
E-mail: 104704.2600@compuserve.com

Amphenol Corp. Argentina

Buenos Aires
Phone: +54-11-4815-6886
E-mail: ventas@amphenol.com.ar

Amphenol do Brasil LTDA.

Sao Paulo SP
Phone: +55-11-3815-1003
E-mail: vendas@amphenol.com.br

Amphenol Corp. Mexico

Mexico D.F.
Phone: +52-55-5258-9984
E-mail: info@amphenolmexico.com

Times Fiber Communications, Inc.

Wallingford, CT, U.S.A.
Phone: 1-203-265-8500
E-mail: aphinfo@amphenol.com

EUROPE

Amphenol European Sales Operations

Houten, The Netherlands
Phone: +31-30-6358-000
E-mail: info@amphenol-nl.com

Amphenol GmbH

Wien, Austria
Phone: +43-1-895-1511
E-mail: info@amphenol-at.com

Amphenol Iberica

Madrid, Spain
Phone: +34-91-673-2235
E-mail: info@amphenol-it.com

Amphenol Italia S.p.A.

Lainate (Milano), Italy
Phone: +39-2-939-04192
Email: info@amphenol-it.com

Amphenol Scandinavia

Upplands Vasby, Sweden
Phone: +46-8-594-10040
E-mail: info@amphenol-se.com

Amphenol Limited

Whitstable, Kent, Great Britain
Phone: +44-1-227-773-200
E-mail: info@amphenol.co.uk

Amphenol Socoapex S.A.

Thyes, Cedex, France
Phone: +33-4-50-89-28-00
E-mail: fo-specials@amphenol-socapex.fr

Amphenol Air LB GmbH

Saarlouis, Germany
Phone: 49-6831-981-00
Email: info@amphenol-airlb.de

ASIA & R.O.W.

Amphenol Japan. K.K.

Chiyoda-ku, Tokyo, Japan
Phone: +81-3-3263-5611
E-mail: info@amphenol.co.jp

Amphenol Daeshin Electronics

Precision Co., Ltd.
Kyungki-Do, Korea
Phone: +82-32-680-3800
E-mail: info@amphenol.co.kr

Amphenol East Asia Ltd.

Kowloon, Hong Kong
Phone: +852-2699-2663
E-mail: info@amphenol.com.hk

Amphenol Taiwan Corp.

Taoyuan, Taiwan
Phone: +886-3-379-5677
E-mail: info@amphenol.com.tw

Amphenol South China

Bao An, Shenzhen, China
Phone: +86-755-719-9622
E-mail: +info@amphenol.com.cn

Shenzhen (China) Office

Shenzhen, China
Phone: +86-755-368-3575
E-mail: info@amphenol.com.cn

Guangzhou Amphenol

Electronics Communications
Guangzhou, China
Phone: +86-20-3869-8808
E-mail: Thomang@gecamphenol.com

Singapore Office

Phone: +65-294-2128
E-mail: info@amphenol.com.sg

Amphetronix Limited

Bhosari Industrial Area
Pune, India
Phone: +91-20-7120363
E-mail: sales@amphenol-in.com

Amphenol Australia Ltd.

Keysborough Vic, Australia
Phone: +61-3-8796-8888
E-mail: info@amphenol.com.au

X-ON Electronics

Largest Supplier of Electrical and Electronic Components

Click to view similar products for [Fibre Optic Connectors](#) category:

Click to view products by [Amphenol](#) manufacturer:

Other Similar products are found below :

[0004700001](#) [6100-R](#) [6313](#) [F709722200](#) [F709730000](#) [F718183204](#) [F727403500](#) [F727752800](#) [8119](#) [9440F20-27S-190](#) [944-120-6001](#)
[9441F10SL-3S](#) [9444W28-21S](#) [9444W36-10S](#) [9446W20-16S](#) [953-101-5310-P](#) [954-101-57202B](#) [A0270169](#) [12-9122](#) [12-5702](#) [AX101713](#)
[AX102420](#) [AX103923](#) [AX104024](#) [AX104193](#) [AX104230](#) [AX104562](#) [AX105203-B25](#) [AX105205-S1](#) [EHSC2M](#) [17-300800](#) [181-011-126](#)
[181-011-S](#) [181-057-126](#) [NKSOPBUY](#) [20500002116](#) [2064996-1](#) [20800001065](#) [2170](#) [9132](#) [2612](#) [2620](#) [9291](#) [9440F16-10S](#) [9440F20-18S](#)
[9446F16-10S-190](#) [953-106-50231](#) [953-120-5003](#) [955-120-5110](#) [1757711-1](#)