

REVISIONS					
REV	ECO	DESCRIPTION	DATE	BY	APPR
A1	-	RELEASE NEW DRAWING	15JUN18	SULLEN	TOMMY
A2	-	REVISED DRAWING	10JUL20	JHEAD	DH

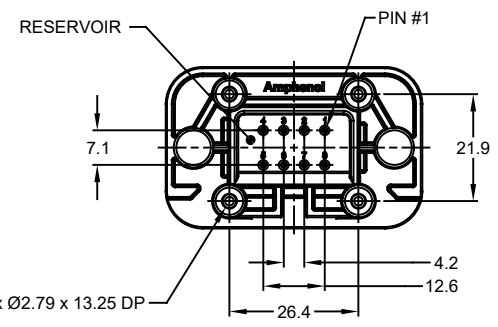

RECOMMENDED SCREW: 4-20 [M3.12 x 1.27]
 THREAD-FORMING SCREW,
 TORQUE: 6-10 IN-LB [0.68-1.13 NM]

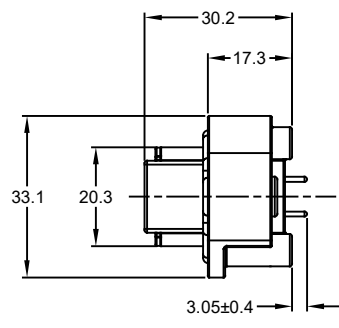
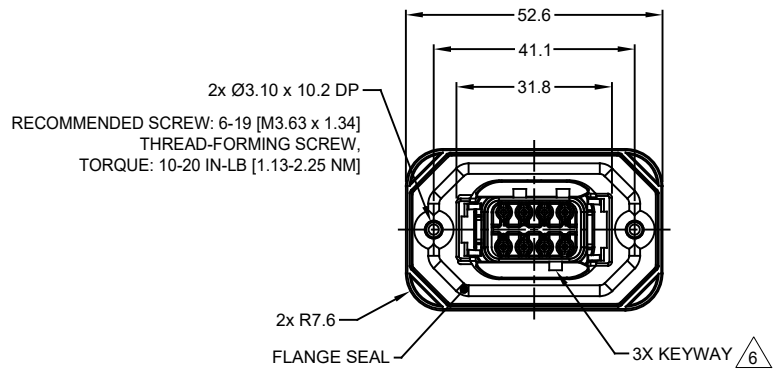
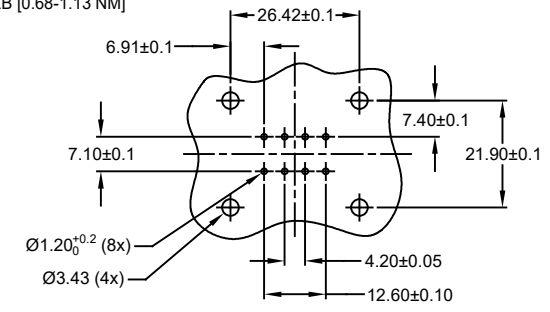
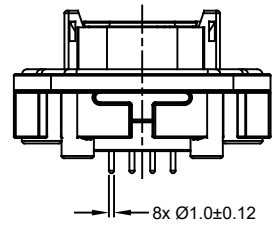
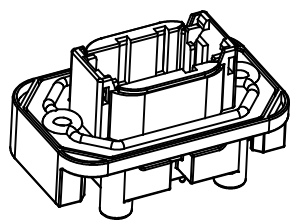

RECOMMENDED PCB LAYOUT
 VIEW FROM COMPONENTS
 SIDE OF PCB

NOTES: UNLESS OTHERWISE SPECIFIED

- MATERIAL:
 HOUSING: THERMOPLASTIC, GREY
 SEAL: SILICONE RUBBER
 CONTACT: COPPER ALLOY
- CONTACT PLATING: SEE SHEET 2
- MODIFICATIONS: FLANGE; STRAIGHT PCB MOUNT
- SPECIFICATIONS:
 4.1 CURRENT RATING: 7.5 AMPS
 4.2 OPERATING TEMPERATURE: -55°C TO +125°C
 4.3 DIELECTRIC WITHSTANDING VOLTAGE: LESS THAN 2 MILLIAMPS CURRENT LEAKAGE @ 1500 VOLTS AC
 4.4 INSULATION RESISTANCE: 1000 MEGOHMS MIN @ 25°C
 4.5 MOISTURE RESISTANCE: IP67 (MATED CONDITION)
 4.6 MATING CYCLE DURABILITY: 100 CYCLES
 4.7 RoHS COMPLIANT

- MATING PART: ATM06-08SX-*
 (X = A,B,C,D KEYS ; * = MODIFICATIONS AND COLORS)
 △ SEE SHEET 2 FOR OTHER KEY ARRANGEMENTS AND COLORS
- ALL DIMENSIONS ARE FOR REFERENCE USE ONLY
- POTTED CONNECTORS SPECIFIED FOR UP TO 5 P.S.I. APPLICATIONS.

ATM15-08PX-BMXX		DESCRIPTION		ITEM
QUANTITY	PART NUMBER	MATERIALS LIST		
UNLESS OTHERWISE SPECIFIED		SIGNATURES		DATE
1) All dimensions are in metric (mm).		DRAWN: SULLEN ZHANG		15JUN18
2) Tolerances are as follows:		CHECKED: ORION LI		15JUN18
1 PL DEC ±0.30		ENGINEER:		
2 PL DEC ±0.15		APPROVAL: TOMMY XIE		15JUN18
3 PL DEC ±0.08		CUSTOMER:		
3) Note reference = △		THIS DRAWING IS SUPPLIED FOR INFORMATION ONLY. DESIGN FEATURES, SPECIFICATIONS AND PERFORMANCE DATA SHOWN HEREON ARE THE PROPERTY OF THE AMPHENOL CORPORATION. NO RIGHTS OF REPRODUCTION ARE IMPLIED. ALL DIMENSIONS ARE SUBJECT TO NORMAL MANUFACTURING VARIATIONS.		
MATERIAL SPECIFICATIONS:		SIZE		REVISION
PROCESS SPECIFICATIONS:		TYPE		
NEXT ASSY:		DWG NO:		
		SCALE		
		B C-		ATM15-08PX-BMXX
		NONE		A2
		SHEET 1 OF 2		

TITLE: PCB MOUNT RECEPTACLE, 8 PIN, STRAIGHT FLANGE, ATM SERIES
 DWG NO: ATM15-08PX-BMXX
 REV: A2
 SH: 1
 OF: 2

REVISIONS					
REV	ECO	DESCRIPTION	DATE	BY	APPR
A1	-	RELEASE NEW DRAWING	15JUN18	SULLEN	TOMMY
A2	-	REVISED DRAWING	10JUL20	JHEAD	DH

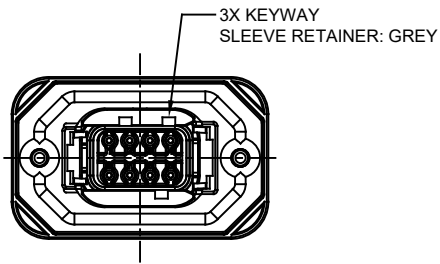

ATM15-08PA-BMXX
KEY A

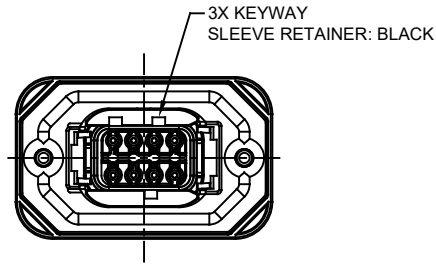

ATM15-08PB-BMXX
KEY B

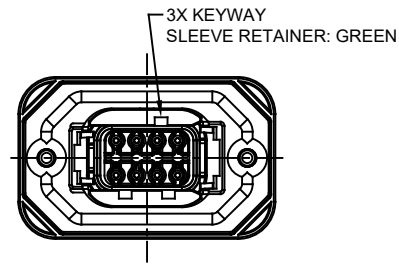

ATM15-08PC-BMXX
KEY C

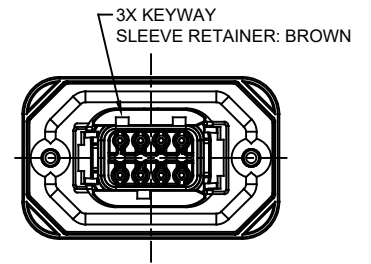

ATM15-08PD-BMXX
KEY D

ATM15-08PA-BMXX VARIANTS		
CONTACT PLATING	POTTING OR NOT IN RESERVOIR	PART NUMBER
GOLD	NO POTTING	ATM15-08PA-BM01
GOLD	POTTING	ATM15-08PA-BM02
TIN	NO POTTING	ATM15-08PA-BM03
TIN	POTTING	ATM15-08PA-BM04

ATM15-08PB-BMXX VARIANTS		
CONTACT PLATING	POTTING OR NOT IN RESERVOIR	PART NUMBER
GOLD	NO POTTING	ATM15-08PB-BM01
GOLD	POTTING	ATM15-08PB-BM02
TIN	NO POTTING	ATM15-08PB-BM03
TIN	POTTING	ATM15-08PB-BM04

ATM15-08PC-BMXX VARIANTS		
CONTACT PLATING	POTTING OR NOT IN RESERVOIR	PART NUMBER
GOLD	NO POTTING	ATM15-08PC-BM01
GOLD	POTTING	ATM15-08PC-BM02
TIN	NO POTTING	ATM15-08PC-BM03
TIN	POTTING	ATM15-08PC-BM04

ATM15-08PD-BMXX VARIANTS		
CONTACT PLATING	POTTING OR NOT IN RESERVOIR	PART NUMBER
GOLD	NO POTTING	ATM15-08PD-BM01
GOLD	POTTING	ATM15-08PD-BM02
TIN	NO POTTING	ATM15-08PD-BM03
TIN	POTTING	ATM15-08PD-BM04

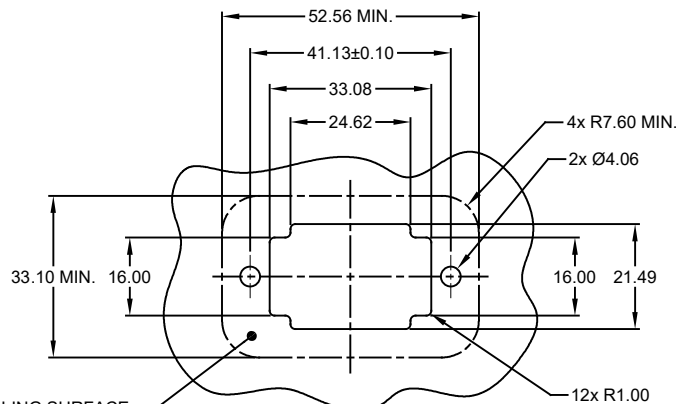

INTERNAL SEALING SURFACE
FINISH TO BE 3.2/ OR BETTER $\sqrt{10.13}$

RECOMMENDED PANEL
CUTOUT

ATM15-08PX-BMXX		DESCRIPTION		ITEM
PART NUMBER		DESCRIPTION		ITEM
QUANTITY		MATERIALS LIST		
UNLESS OTHERWISE SPECIFIED: 1) All dimensions are in metric(mm). 2) Tolerances are as follows: 1 PL DEC ±0.30 Fractions ±1/64 2 PL DEC ±0.15 Angles ±1° 3 PL DEC ±0.08		SIGNATURES		DATE
DRAWN: SULLEN,ZHANG		15JUN18		
CHECKED: ORION,LI		15JUN18		
ENGINEER:		APPROVAL: TOMMY,XIE		15JUN18
MATERIAL SPECIFICATIONS:		CUSTOMER:		
PROCESS SPECIFICATIONS:		THIS DRAWING IS SUPPLIED FOR INFORMATION ONLY. DESIGN FEATURES, SPECIFICATIONS AND PERFORMANCE DATA SHOWN HEREON ARE THE PROPERTY OF THE AMPHENOL CORPORATION. NO RIGHTS OF REPRODUCTION ARE IMPLIED. ALL DIMENSIONS ARE SUBJECT TO NORMAL MANUFACTURING VARIATIONS.		
NEXT ASSY:		SCALE: NONE		
		Sine Systems - www.amphenol-sine.com 44724 Morley Drive Clinton Township, MI 48036		
		BOARDLOCK PCB MOUNT RECEPTACLE, 8 PIN, STRAIGHT FLANGE, ATM SERIES		
SIZE: B C-	TYPE: ATM15-08PX-BMXX	DWG NO: A2	REVISION	
		SHEET 2 OF 2		

TITLE: PCB MOUNT RECEPTACLE, 8 PIN, STRAIGHT FLANGE, ATM SERIES
DWG NO: ATM15-08PX-BMXX
REV: A2
SH: 2
OF: 2

X-ON Electronics

Largest Supplier of Electrical and Electronic Components

Click to view similar products for [Automotive Connectors](#) category:

Click to view products by [Amphenol](#) manufacturer:

Other Similar products are found below :

[003-018-000](#) [60403001](#) [60993906-B](#) [M902-2131](#) [M902-2161](#) [72.330.1035.1](#) [73.353.4028.0](#) [F119300-B](#) [F166900](#) [F258300-B](#) [F358300-B](#)
[F407400](#) [F444110](#) [F487000](#) [F509500B-B](#) [827153-1](#) [8N1515-32-24P](#) [9-1326729-8](#) [925474-1](#) [928905-1](#) [964562-4](#) [968782-1](#) [GT17SA-8DS-](#)
[HU](#) [98891-1012](#) [98947-1016](#) [12004475-L](#) [12010290](#) [12010309-B](#) [12015454](#) [12020219-B](#) [12020308](#) [12041318-B](#) [12052225-L](#) [12052466](#)
[12059125](#) [12064869](#) [12004327-B](#) [12010503-B](#) [12015308](#) [12015384](#) [12015909](#) [1-21030-1](#) [12041254](#) [12041318](#) [12047946-B](#) [12047957](#)
[12047957-L](#) [12059473](#) [12066261](#) [12110546](#)