

Amphenol®

QPL Backshells



アマフェノール

Backshells

Within Amphenol's wide range of interconnect products is a full range of backshell hardware. Customers can take advantage of Amphenol's global synergy for connectors, backshells and cable harnessing in one place for all their interconnect needs. Plus, coming to Amphenol for a custom design of a backshell means that customers benefit from the vast amount of experience this global company has in designing interconnect solutions.

Amphenol Japan

Connecting People & Technology

TABLE OF CONTENTS

HOW TO SELECT A BACKSHELL	5	NON-ENVIRONMENTAL	53
How to Select a Backshell	5	Connector K	53-55
Backshell Type	6-7	Connector L	56-58
Angles/Profiles & Coupling Styles	8	<hr/>	
Connector Group Code	9-13	NON-ENVIRONMENTAL EMI/RFI	59
Materials & Finishes	14	Connector J	59-63
Assembly Torque Value & Style 2 Configuration	15	Connector K	64-66
<hr/>		Connector L	67-69
BAND LOCK ADAPTER	16	<hr/>	
Connector J	16	PRE-SHIELD ADAPTER	70
Connector K	17	Connector J	70
Connector L	18	Connector K	71
<hr/>		Connector L	72
CRIMP RING ADAPTER	19	<hr/>	
Connector J	19	QUICK CLAMP	73
Connector K	20	Connector J	73
Connector L	21	Connector K	74
<hr/>		Connector L	75
DUST CAPS	22	<hr/>	
Plugs Receptacles	22-29	SHRINK BOOT ADAPTER	76
<hr/>		Connector J	76
ENVIRONMENTAL	30	Connector K	77
Connector J	30-34	Connector L	78
<hr/>		<hr/>	
ENVIRONMENTAL EMI/RFI	35	STRAIN RELIEF CLAMP	79-90
Connector J	35-39	<hr/>	
Connector K	40-44	HEXAGON PANEL NUT	91
Connector L	45-49	<hr/>	
<hr/>		ELECTRICAL, CIRCULAR, RECEPTACLE, THREADED SERIES	92
GROMMET NUT	50	<hr/>	
Connector J	50	APPENDIX	93
Connector K	51		
Connector L	52		

HOW TO SELECT A BACKSHELL

1. Select the Backshell Type, pg. 6-7 (i.e. [Non-Environmental backshell](#))
2. Select Angle, pg. 8 (i.e. [Straight](#))
3. Select Coupling Style, pg. 8 (i.e. [Spin](#))

In order to complete steps 4-9, you must know the connector specification. For example, we'll use connector D38999/26WB35PN to walk through the remaining steps of selecting a backshell.

4. Select Connector Group Code based on your connector specification, pg. 9-13 (i.e. [L](#))
5. Go to Table of Contents, pg. 4, to find the page numbers your selection resides (i.e. [page 56-58](#))
6. For the material and finish options, review Table-2 on pg. 14 (i.e. [Cadmium Olive Drab over Electroless Nickel](#))

*Recommended to follow the same finish as connector

In order to complete step 7, you must know the actual cable diameter. For example, we'll use the cable diameter of 0.20 inches to walk through the remaining steps of selecting a backshell.

7. Determine the clamp size by using the table on the product page. (i.e. [page 56](#)) For this example a 0.20 in cable diameter will be used. (i.e. [Clamp size-02](#))

*Omit if not available in the backshell selected

8. If applicable, determine backshell length using the table on the product page. (i.e. [page 56](#); 2.53 = A)

*Omit if not available in the backshell selected/ Skip for 90° and 45° backshells

9. Build a part number based on the selections you made (i.e. [M85049/2111W02A](#))

*Contact Amphenol Pcd if you can not find your preferences to meet your application, we may be able to support under priority part number

Cross Reference

If you have a Military part number or other manufacturer's part number for which you are looking for an equivalent item, we have provided a cross-reference on our web link: <http://www.backshellworld.com/crossreference.aspx>

Customize

Backshells for Military & Aerospace applications are governed by SAE, AS85049 standard and Amphenol Backshells are designed to meet the requirement of this standard. Though this standard covers the most popular styles of backshells, many applications call for additional styles and designs. Here is where the capability of Amphenol can support you from the concept to product realization and thereby your unique specification need is satisfied.

Please visit our web link for further help: <http://www.backshellworld.com/customdesign.asp>

BACKSHELL TYPE

Amphenol Backshells are available in several different types, designed for optimum performance in the application or environment it will be used in. For example, in ground and naval applications, the robustness and environmental sealing may be more important, weight may be the prime consideration for Space and Aerospace applications. The following overview explains the various families of Amphenol Backshells with its applications. Some families of backshells shown here can be used without any additional protection. Some other types of backshells shown are generally used with heat shrink boots or similar protection/strain relief mechanisms depending upon the specific requirements. Also, there are some clamps & nuts for the applications where varying degrees of strain reliefs and cable holding will suffice and weight savings is of higher importance.



Non-Environmental Backshell

Effective cable holding mechanism with good strain relief when the environmental protection of the cable termination area is not a concern. Amphenol offers cost-effective solutions by eliminating extra sealing parts. Suitable for an inside-the-box/climate controlled room application where heavy cabling should be supported with adequate strain relief.

*Example shown on pg. 5

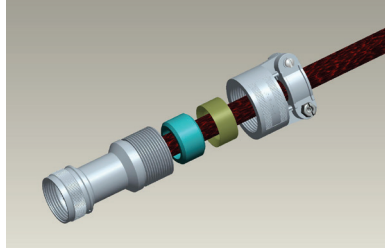

Environmental Backshell

Not only provide the cable support and strain relief, but ensure the cable sealing and environment protection by means of high quality sealing grommet and grommet follower. The strain relief nut is tightened, squeezing the grommet onto the cable jacket during assembly. Provides 6 feet water sealing protection when used with perfectly jacketed cable, and suitable for harsh environment applications.

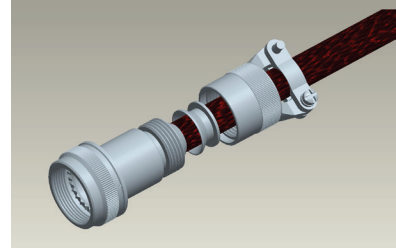

Non-Environmental EMI/RFI Backshell

Offering 360-degree electromagnetic and radio frequency noise isolation shielding in addition to standard features available with the Non-Environmental type. Available in straight, 90 degree and 45 degree varieties. Accommodates both individual and overall shielding.

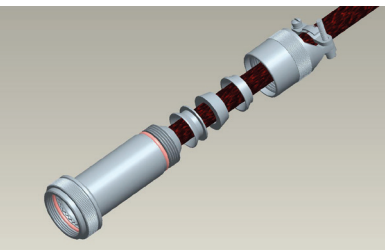

Environmental EMI/RFI Backshell

Ideal choice for heavy duty cabling solutions in harsh environments where electromagnetic and radio frequency noises are to be isolated. Accommodates both individual and overall shielding.

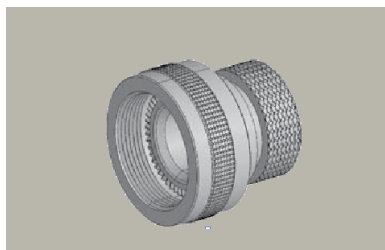

Shrink Boot Adapter

A good solution when the unshielded cables are terminated with heat shrink boots. It has a groove where the boot lip can be held which provides good grip apart from sufficient space inside for the cable looping. Using the heat shrink boot is one way of providing environmental protection and strain relief to cable termination. Using a suitable adapter is essential to ensure the repair ability.

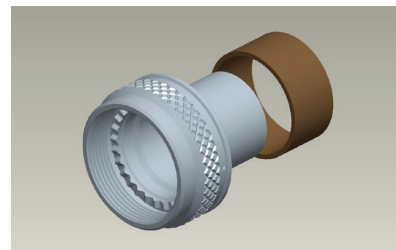

Crimp Ring Adapter

Many cable terminations where heat shrink boots are used; will require provision for terminating the screens, too. It is achieved in this type of backshell through a ring, which can be crimped to the backshell body holding the screens in between.

BACKSHELL TYPE

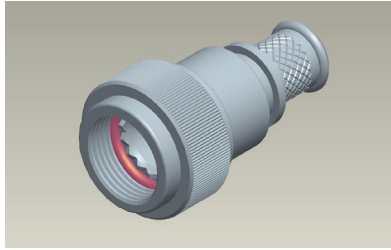

Band Lock Adapter

A high quality band will do the job with this backshell. Tempered bands are tightened over the shields, which are pulled over the banding area using a special assembly tool. Suitable over cover by heat shrink boot or some other method as chosen by the designer could be used. Both crimp ring and banded terminations give a low DC resistance.

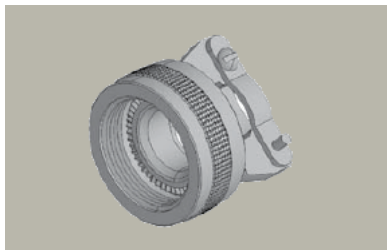

Strain Relief Clamps

If environmental protection is not a concern and weight savings is a major consideration this strain relief clamp is what you need. It secures and "tidys-up" the light/medium cable and also provides good strain relief at the termination area.

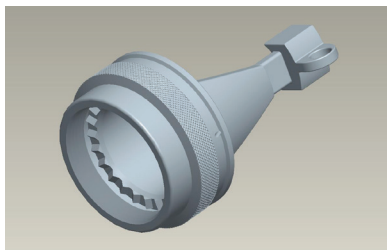

Quick Clamp

A light weight clamp used for securing and "tidying up" cable into a desired direction. Used in interior wiring of aircraft.

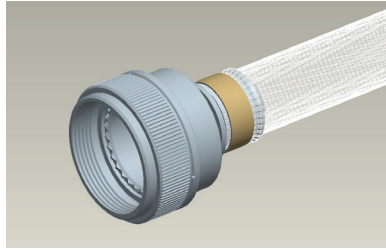

Pre-Shield Adapter

This adapter comes with a pre-cut braid that is fitted to the adapter for easy assembly. The braid overlaps with the cable braid. Effective shielding takes place due to the 360° contact of the braid. Designed to accept heat shrink boot. Ease of assembly saves time for cable termination.

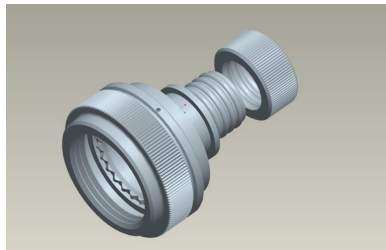

Lamp Thread Adapter

An adapter with threads similar to that in the lamp base for shield termination. An effective, easy and quick method of shield termination and field maintenance. Termination area can accept a nut as well as a clamp. The nut option enables the use of heat shrink boot and the clamp option will facilitate the strain relief clamping without heat shrink boot after the shield/cable termination.

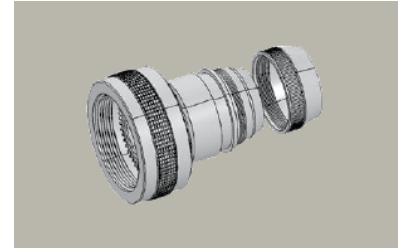

SQ Adapter

The SQ adapter is a cost-effective way to terminate the braid to the adapter. The braid is pulled over the conical shape to the rear end of the adapter and then tied. The end nut is tightened to ensure adequate grip for the shielding. A heat shrink boot can be used with this adapter as well.

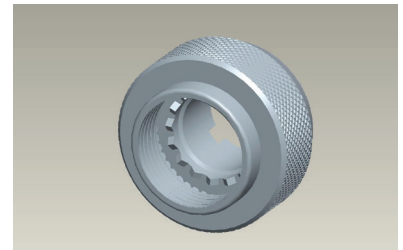

Grommet Nut

Provides a good grommet-holding force for the crimp connectors when expensive and heavy backshells are not used. Such holding force is essential to hold the contacts and grommet in place when terminated with wire bundles.

ANGLES/PROFILES & COUPLING STYLES

Angles/Profiles

Amphenol Backshells are available in three different angular profiles: straight, 90 degree and 45 degree. These profiles will meet most of the cable routing required in the interconnect market. We can also make additional profiles if required. Please go to the web link <http://www.backshellworld.com/customdesign.asp> to contact Amphenol about your specific backshell needs.

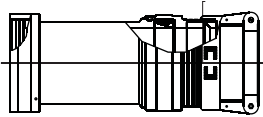

Straight Backshells

Available in different lengths and cable entry diameters for most applications. Different cable and braid terminating systems are also available as shown in the respective product sections.

*Example shown on pg. 5

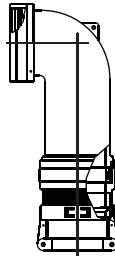

90° Angled Backshells

Many applications require the cable to be bent and routed rather than straight routed. Amphenol offers a 90° angled style in all the backshell families for space saving and convenience.

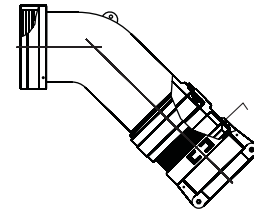

45° Angled Backshells

Amphenol offers further design flexibility with a backshell that allows the cable to be routed 45° to the axis of the assembly.

Coupling Styles

Various coupling styles are available for the coupling between the backshell and the connector. Popular styles are shown in the respective backshell sections, and custom profiles can be designed. Please go to the web link <http://www.backshellworld.com/customdesign.asp> to contact Amphenol about your specific backshell needs.



Spin Coupling

A captivated coupling nut within the backshell which provides the following advantages: Free rotation of the coupling nut making the assembly of the backshell to the connector easy without turning the entire backshell body. Lock wire holes are provided on the coupling nut to prevent accidental decoupling.

*Example shown on pg. 5



Self-Lock Coupling

Same as the Spin Coupling style with the additional feature of "self-locking." Internally locks the movement of the coupling nut so that accidental decoupling is prevented. Used in higher vibration conditions.

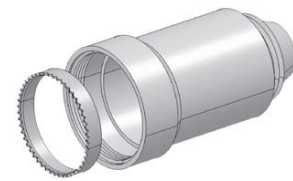

Direct Coupling

The coupling nut is eliminated in this design, and the backshell directly threads to the connector. For applications where simple direct connectivity is sufficient.

CONNECTOR GROUP CODE

Military Connector Specification	Series/ Class	Connector Group Code
40M38277		K
40M39569		J
BS9520	G0001	K
BS9520	G0002	K
BS9520	G0003	L
BS9522 F0001	Patt 602	J
BS9522 F0012	Patt 615	M
BS9522 F0017	Patt 105	N
BS9522 F0020	Patt 608	N
BS9522 F0029	Patt 616	K
BS9522 F0042		J
BS9522 N0001	Patt 603	N
BS9522 N0003	Patt 614	K
CECC 75201.001		J
CECC 75201.002		L
DEF 5326-3		J
EN 2997		J
EN 3645		L
EN 3646		J
EN 3372		M
ESC 10		J
ESC 11		J
JN1003		M
LN29504		J
LN29728		J
LN29729		M
MIL-C-81703	3	J
MIL-DTL-26482	2	J
MIL-DTL-38999	I	K
MIL-DTL-38999	II	K
MIL-DTL-38999	III	L
MIL-DTL-38999	IV	L
MIL-DTL-5015	MS340	J
MIL-DTL-5015	MS345	J
MIL-DTL-83723	I	J
MIL-DTL-83723	III	J
NAS 1599		J
NFC93422	HE302	J
NFC93422	HE306	M
NFC93422	HE308	K
NFC93422	HE309	K
NFL 54140		J
PAN 6432-1		J
PAN 6432-2		J
PAN 6433-1		K
PAN 6433-2		M
VG 96912	2	K
VG 96912	1	M

Military Connector Part Number	Specifications	Series/ Class	Connector Group Code
D38999/20	MIL-DTL-38999	III	L
D38999/24	MIL-DTL-38999	III	L
D38999/26	MIL-DTL-38999	III	L
D38999/40	MIL-DTL-38999	IV	L
D38999/42	MIL-DTL-38999	IV	L
D38999/46	MIL-DTL-38999	IV	L
D38999/47	MIL-DTL-38999	IV	L
M83723/01	MIL-DTL-83723	I	J
M83723/02	MIL-DTL-83723	I	J
M83723/03	MIL-DTL-83723	I	J
M83723/04	MIL-DTL-83723	I	J
M83723/05	MIL-DTL-83723	I	J
M83723/06	MIL-DTL-83723	I	J
M83723/07	MIL-DTL-83723	I	J
M83723/08	MIL-DTL-83723	I	J
M83723/13	MIL-DTL-83723	I	J
M83723/14	MIL-DTL-83723	I	J
M83723/36	MIL-DTL-83723	I	J
M83723/37	MIL-DTL-83723	I	J
M83723/38	MIL-DTL-83723	I	J
M83723/39	MIL-DTL-83723	I	J
M83723/40	MIL-DTL-83723	I	J
M83723/41	MIL-DTL-83723	I	J
M83723/42	MIL-DTL-83723	I	J
M83723/43	MIL-DTL-83723	I	J
M83723/48	MIL-DTL-83723	I	J
M83723/49	MIL-DTL-83723	I	J
M83723/65	MIL-DTL-83723	III	J
M83723/66	MIL-DTL-83723	III	J
M83723/67	MIL-DTL-83723	III	J
M83723/68	MIL-DTL-83723	III	J
M83723/69	MIL-DTL-83723	III	J
M83723/71	MIL-DTL-83723	III	J
M83723/72	MIL-DTL-83723	III	J
M83723/73	MIL-DTL-83723	III	J
M83723/74	MIL-DTL-83723	III	J
M83723/75	MIL-DTL-83723	III	J
M83723/76	MIL-DTL-83723	III	J
M83723/77	MIL-DTL-83723	III	J
M83723/78	MIL-DTL-83723	III	J
M83723/82	MIL-DTL-83723	III	J
M83723/83	MIL-DTL-83723	III	J
M83723/84	MIL-DTL-83723	III	J
M83723/85	MIL-DTL-83723	III	J
M83723/86	MIL-DTL-83723	III	J
M83723/87	MIL-DTL-83723	III	J
M83723/91	MIL-DTL-83723	III	J
M83723/92	MIL-DTL-83723	III	J
M83723/95	MIL-DTL-83723	III	J
M83723/96	MIL-DTL-83723	III	J

CONNECTOR GROUP CODE

Military Connector Part Number	Specifications	Series/Class	Connector Group Code
M83723/97	MIL-DTL-83723	III	J
M83723/98	MIL-DTL-83723	III	J
MS27466	MIL-DTL-38999	I	K
MS27467	MIL-DTL-38999	I	K
MS27468	MIL-DTL-38999	I	K
MS27472	MIL-DTL-38999	II	K
MS27474	MIL-DTL-38999	II	K
MS27475	MIL-DTL-38999	II	K
MS27479	MIL-DTL-38999	II	K
MS27480	MIL-DTL-38999	II	K
MS27481	MIL-DTL-38999	II	K
MS27482	MIL-DTL-38999	II	K
MS27484	MIL-DTL-38999	II	K
MS27497	MIL-DTL-38999	II	K
MS27498	MIL-DTL-38999	I	K
MS27500	MIL-DTL-38999	II	K
MS27652	MIL-DTL-38999	I	K
MS27653	MIL-DTL-38999	I	K
MS27654	MIL-DTL-38999	I	K
MS27656	MIL-DTL-38999	I	K
MS27665	MIL-DTL-38999	I	K
MS3400	MIL-DTL-5015	MS340/MS245	J
MS3401	MIL-DTL-5015	MS340/MS245	J
MS3404	MIL-DTL-5015	MS340/MS245	J
MS3406	MIL-DTL-5015	MS340/MS245	J
MS3408	MIL-DTL-5015	MS340/MS245	J
MS3409	MIL-DTL-5015	MS340/MS245	J
MS3412	MIL-DTL-5015	MS340/MS245	J
MS3424	MIL-C-81703	3	J
MS3446	MIL-C-81703	3	J
MS3450	MIL-DTL-5015	MS340/MS345	J
MS3451	MIL-DTL-5015	MS340/MS345	J
MS3454	MIL-DTL-5015	MS340/MS345	J
MS3456	MIL-DTL-5015	MS340/MS345	J
MS3459	MIL-DTL-5015	MS340/MS345	J
MS3464	MIL-C-81703	3	J
MS3467	MIL-C-81703	3	J
MS3468	MIL-C-81703	3	J
MS3470	MIL-DTL-26482	2	J
MS3471	MIL-DTL-26482	2	J
MS3472	MIL-DTL-26482	2	J
MS3474	MIL-DTL-26482	2	J
MS3475	MIL-DTL-26482	2	J
MS3476	MIL-DTL-26482	2	J
NAS1599	MIL-C-81703	3	J

Military Connector Part Number	Specifications	Series/Class	Connector Group Code
NAS1641	MIL-C-81703	3	J
NAS1642	MIL-C-81703	3	J
NAS1643	MIL-C-81703	3	J
NAS1650	MIL-C-81703	3	J
NAS1651	MIL-C-81703	3	J
NAS1652	MIL-C-81703	3	J
NAS1653	MIL-C-81703	3	J
NAS1692	MIL-C-81703	3	J
NAS1693	MIL-C-81703	3	J
NAS1694	MIL-C-81703	3	J
NAS1699	MIL-C-81703	3	J
NAS1700	MIL-C-81703	3	J
NAS1701	MIL-C-81703	3	J
NAS1702	MIL-C-81703	3	J
NATC00	SSQ21635		L
NATC06	SSQ21635		L
NATC07	SSQ21635		L
NB4	40M39569		J
NB6	40M39569		J
NB6G	40M39569		J
NB7	40M39569		J
NBO	40M39569		J
NLS6	40M39569		K
NLS6G	40M39569		K
NLS7	40M39569		K
NLSO	40M39569		K

Manufacturer Part Number	Manufacturer	Connector Group Code	Manufacturer Part Number	Manufacturer	Connector Group Code
10-475	Amphenol/ Bendix/ Socapex/ Pyle	K	AE83	Aero-Electric	J
118	Amphenol/ Bendix/ Socapex/ Pyle	J	AFD	Deutsch	J
162GB	Amphenol/ Bendix/ Socapex/ Pyle	N	AFD5	Deutsch	J
2PSN	Plessey Connector	N	AFE	Deutsch	J
381	Deutsch	J	B	Amphenol/ Bendix/ Socapex/ Pyle	J
418-1	Amphenol/ Bendix/ Socapex/ Pyle	K	BE	Amphenol/ Bendix/ Socapex/ Pyle	J
418-2	Amphenol/ Bendix/ Socapex/ Pyle	K	BL	Flight Connector	L
418-5	Amphenol/ Bendix/ Socapex/ Pyle	M	BT	Amphenol/ Bendix/ Socapex/ Pyle	J
486	Amphenol/ Bendix/ Socapex/ Pyle	J	BY1	Amphenol/ Bendix/ Socapex/ Pyle	J
518	Amphenol/ Bendix/ Socapex/ Pyle	J	CGK	ITT Cannon	M
602GB	Amphenol/ Bendix/ Socapex/ Pyle	J	CN0930	TRW	J
62GB	Amphenol/ Bendix/ Socapex/ Pyle	N	CNO	G & H Technology	L
65	Glenair	L	CNO930	Labinal/ Cinch	J
652	Amphenol/ Bendix/ Socapex/ Pyle	J	CT	Burndy	K
66	Glenair	L	CT	Plessey Connector	K
711	Amphenol/ Bendix/ Socapex/ Pyle	J	CT-R	AB Electronics	K
801	Amphenol/ Bendix/ Socapex/ Pyle	J	CT-R	Plessey Connector	K
837	Deutsch	J	CV340	ITT Cannon	J
83723	Souriau	J	CV345	ITT Cannon	J
83730	Deutsch	J	D817	Deutsch	J
851	Souriau	N	DBA	Deutsch	J
8520	Souriau	J	DBA7	Deutsch	J
8525	Souriau	J	DBAS	Deutsch	J
8526	Souriau	J	DFE	Deutsch	J
853	Souriau	J	DIV4	Deutsch	L
8533	Souriau	J	DL	Deutsch	J
8534	Souriau	J	DL6	Deutsch	J
857	Souriau	J	DTS	Deutsch	L
89	Souriau	J	DVG	Deutsch	J
8D	Souriau	L	EA	Amphenol/ Bendix/ Socapex/ Pyle	J
8LT	Souriau	K	EB	Amphenol/ Bendix/ Socapex/ Pyle	J
8T	Souriau	M	EEG	Amphenol/ Bendix/ Socapex/ Pyle	J
91-483	Amphenol/ Bendix/ Socapex/ Pyle	K	ES	Amphenol/ Bendix/ Socapex/ Pyle	J
944	Matrix	J	ET	Amphenol/ Bendix/ Socapex/ Pyle	J
951	Deutsch	J	FDDBA	Deutsch	J
951-50	Deutsch	J	FF	Deutsch	J
981	Matrix	J	FF	Flight Connector	J
983	Deutsch	J	FH	Flight Connector	J
991	Deutsch	J	HDJ	Deutsch	M
999.1	Deutsch	J	HTMF	ITT Cannon	J
ABJ	AB Electronics	K	JT	Amphenol/ Bendix/ Socapex/ Pyle	K
AE22	Aero-Electric	L	JT 3400	J-Tech	J
AE46	Aero-Electric	K	JT 3450	J-Tech	J
AE47	Aero-Electric	K	JT-R	FKI	K
AE48	Aero-Electric	K	JT-R	Teldix	K
AE49	Aero-Electric	K	JTVG 95234	J-Tech	J
AE55	Aero-Electric	J	JVS	Souriau	L
AE77	Aero-Electric	J	KJ	ITT Cannon	K
			KJA	ITT Cannon	L

CONNECTOR GROUP CODE

Manufacturer Part Number	Manufacturer	Connector Group Code	Manufacturer Part Number	Manufacturer	Connector Group Code
KJAD/V4	ITT Cannon	L	RR50	Deutsch	J
KJL	ITT Cannon	K	RR70	Deutsch	J
KV-R	ITT Cannon	J	RR70	Deutsch	J
LJT	Amphenol/ Bendix/ Socapex/ Pyle	K	SA	SAE	J
LS	Amphenol/ Bendix/ Socapex/ Pyle	J	SJT	Amphenol/ Bendix/ Socapex/ Pyle	M
LTT	FKI	K	STT	FKI	M
MB1	Matrix	J	STT	ITT Cannon	M
MB3	Matrix	J	T3	Amphenol/ Bendix/ Socapex/ Pyle	L
MB9	Matrix	K	TT	FKI	K
MD	Matrix	J	TT/TTPQ	ITT Cannon	K
MF	ITT Cannon	J	TT/TTPQ	ITT Cannon	K
MFG	ITT Cannon	J	TV	Amphenol/ Bendix/ Socapex/ Pyle	L
MK 12	AB Electronics	N	TVP	FKI/ Bendix	L
MK 18	AB Electronics	N	TVRB	Amphenol/ Bendix/ Socapex/ Pyle	L
MK 8	AB Electronics	N	TVS	Amphenol/ Bendix/ Socapex/ Pyle	L
MK12	Plessey Connector	N	VTT	FKI	L
MK25	Plessey Connector	K			
MK38	Plessey Connector	K			
MK8	Plessey Connector	N			
ML94	Matrix	L			
MQ3	Matrix	J			
MT3	Matrix	J			
MT93	Matrix	L			
P5	Plessey Connector	N			
PL	Deutsch	L			
PT	ITT Cannon	N			
PT33	FKI	N			
PT33SE	FKI	N			
PT44	FKI	N			
PT44SE	FKI	N			
PT55	FKI	N			
PT55SE	FKI	N			
PT77	FKI	N			
PT77SE	FKI	N			
PTG55	FKI	N			
PTG55SE	FKI	N			
PTS-DR	Amphenol/ Bendix/ Socapex/ Pyle	J			
PT-SE	ITT Cannon	N			
PV7	ITT Cannon	J			
PVA	ITT Cannon	J			
PV-G	ITT Cannon	J			
PVJ	ITT Cannon	J			
PV-S	ITT Cannon	J			
PVW	ITT Cannon	J			
PVX	ITT Cannon	J			
RD1	Raychem	J			
RR	Deutsch	J			
RR20	Deutsch	J			

Manufacturer's Part Number Prefix	Connector Group Code	Burdny		Plessey Connector	
AB Electronics		CT	K	2PSN	N
ABJ	K	Deutsch		CT	K
CT-R	K	381	J	CT-R	K
MK 12	N	837	J	MK12	N
MK 18	N	83730	J	MK25	K
MK 8	N	RR70	J	MK38	K
Aero-Electric		RR70	J	MK8	N
AE22	L	FKI		P5	N
AE46	K	JT-R	K	Raychem	
AE47	K	LTT	K	RDI	J
AE48	K	PT33	N	Souriau	
AE49	K	PT33SE	N	83723	J
AE55	J	PT44	N	851	N
AE77	J	PT44SE	N	8520	J
AE83	J	PT55	N	8525	J
Amphenol/ Bendix/ Socapex/ Pyle		PT55SE	N	8526	J
10-475	K	PT77	N	853	J
118	J	PT77SE	N	8533	J
162GB	N	PTG55	N	8534	J
418-1	K	PTG55SE	N	857	J
418-2	K	STT	M	89	J
418-5	M	TT	K	8D	L
486	J	VTT	L	8LT	K
518	J	TVP	L	8ST	M
602GB	J	Flight Connector		8T	K
62GB	N	BL	L	JVS	L
652	J	FF	J	Teldix	
711	J	FH	J	JT-R	K
801	J	G & H Technology		TRW/Cinch	
91-483	J	CNO	L	CN0930	J
B	J	Glenair			
BE	J	65	L		
BT	J	66	L		
BY1	J	ITT Cannon			
EA	J	CGK	M		
EB	J	CV340	J		
EEG	J	CV345	J		
ES	J	HTMF	J		
ET	J	KJ	K		
JT	K	KJA	L		
LJT	K	KJAD/V4	L		
LS	J	KJL	K		
PTS-DR	J	MB3	J		
SJT	M	MB9	K		
T3	L	MD	J		
TV	L	ML94	L		
TVRB	L	MQ3	J		
TVS	L	MT3	J		
		MT93	L		

MATERIALS & FINISHES

Amphenol offers adapters in the following standard finishes. The base material is aluminum alloy.

- Aluminum parts: As per ASTM B 211, 221, 209, 85, 26
- Steel parts: 300 series, as per AMS-QQ-S-763/ASTM A 582
- Elastomers: fluorosilicone, silicone
- Other parts: Suitable corrosion resistant material
- Nickel Aluminum (NiAl)-Bronze AMS-QQ-C-465

Backshell Plating Finishes (Table 2)

Amphenol Designation	MIL Designation	Finish	Guiding Specifications/Requirements	RoHS
A	A	Anodized, Black*	To meet AS85049 Requirements	Yes
B		Anodized, Hard*	AMS-A-8625, Type-III, Class-1	Yes
L		Nickel, Bright	AMS-QQ-290, Class-1, Grade-F	Yes
M		Electroless Nickel	AMS-C-26074, Class-4, Grade-B	Yes
N	N	Electroless Nickel	To meet AS85049 Requirements	Yes
C		Cadmium, Bright	AMS-QQ-P-416, Type-I, Class-2	No
T		Cadmium, Bright	AMS-QQ-P-416, Type-1, Class 3	No
U		Cadmium Olive Drab	AMS-QQ-P-416, Type-II, Class-3	No
V		Cadmium Olive Drab over Electroless Nickel	AMS-QQ-P-416, Type-II, Class-3 (Cadmium); AMS-C-26074, Class-4, Grade-B (Nickel)	No
W	W	Cadmium Olive Drab over Electroless Nickel	To meet AS85049 Requirements	No
Y		Zinc-Cobalt, Dark Olive Drab	ASTM-B840	Yes
Z		Zinc-Cobalt, Black	ASTM-B840	Yes
ZN		Zinc Nickel (500 Hrs. Salt Spray)	ASTM-B841	Yes
TN		Nickel Fluorocarbon (500 Hrs. Salt Spray)		Yes
S		Passivate- Stainless Steel	AMS-QQ-P-35 or ASTM A 967	Yes
D		Nickel-Stainless Steel	AMS-QQ-290, Class-1, Grade-F	Yes
ST		Tin Plate-Stainless Steel	ASTM B 545 Type-1	Not Tested
E		Cadmium Olive Drab-Stainless Steel	AMS-QQ-P-416	No
F		Cadmium, Black- Stainless Steel	AMS-QQ-P-416	No
K		Unplated-Nickel Aluminum-Bronze		Yes

*Non Conductive coatings, not suitable for EMI applications.

Dust Cap Finishes (Pgs.22-29)

Amphenol Designation	Finish	Guiding Specifications/Requirements	RoHS
A	Hard Anodic Black*	AMS-A-8625 TYPE III ASTM B117	Yes
SD	Zinc Nickel Black	ASTM B 841, Type D	Yes
F	Electroless Nickel	AMS-C-26074 Class 4, Grade B, ASTM-B-733, SC 2, Type II	Yes
W	Cadmium Olive drab Green	SAE-AMS-QQ-P-416	No
T	PTFE Nickel Plating	GMF-002, Type II, Class 1	Yes
EB	Cadmium Free Zn Co Green	ASTM B 840, Grade 6, Type D	Yes
FB	Cadmium Free Zn Co Black	ASTM B 840, Grade 6, Type D	Yes
CD	Passivation over stainless steel	SAE-AMS-QQ-P-35, Type VI	Yes
NB	Un-plated Marine Bronze		Yes

*Non Conductive coatings, not suitable for EMI applications.

ASSEMBLY TORQUE VALUE & STYLE 2 CONFIGURATION

Amphenol recommends the following torque values for its adapters while assembling them to the connectors. These values are based on the coupling thread strength specified in SAE-AS85049 standard.

Assembly Torque Value	
Connector Shell Size	Torque (Inch-Pounds)
8,9	40
3, 10, 10SL, 11	40
7, 12, 12S, 13	40
14, 14S, 15	40
16, 16S, 17	40
18, 19, 27	40
20, 21, 37	80
22, 23	80
24, 25, 61	80
28	100
32	100
36	100
40	120
44	120
48	120

Torque Values for Cable Clamp Screw	
Screw Size	Torque (Inch-Pounds)
2-56	2 ± .5
4-40	4 ± .5
6-32	6 ± 1.0
8-32	8 ± 1.0
10-32	10 ± 1.0
.250-20	12 ± 1.0

*Recommended 75-80% of Values shown for installation

Style 2 Configuration

Some design consideration will require bigger diameter cable to be terminated in the smaller shell size connectors. Cable with heavy/thicker shielding, many wires for different branches/routing are some of the examples. Such cable termination will require a bigger adapter body with cable entry dimensions more than the connector rear side dimensions. Amphenol support this kind of applications too. The coupling end of the adapter will be modified to Style-2 design as shown in the figure in such cases. The overall length of the style-2 design adapters would be increased by approximately 1inch (25.4mm) as shown. This alternate design is applicable for all the 'Backshell Families' listed in this catalogue.

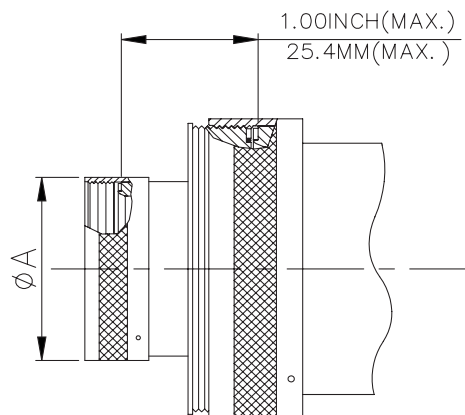

BAND LOCK ADAPTER

STRAIGHT; 90° & 45°; SELF-LOCK

26482 Series II; 5015 (MS345X); 83723 Series III

MIL Part Number

M85049	/82	10	W	02
Series	Slash Sheet	Shell Size (Table A)	Finish (Table 2, pg. 14)	Entry Size (Table A)
	82: Straight 83: 45° 84: 90°			

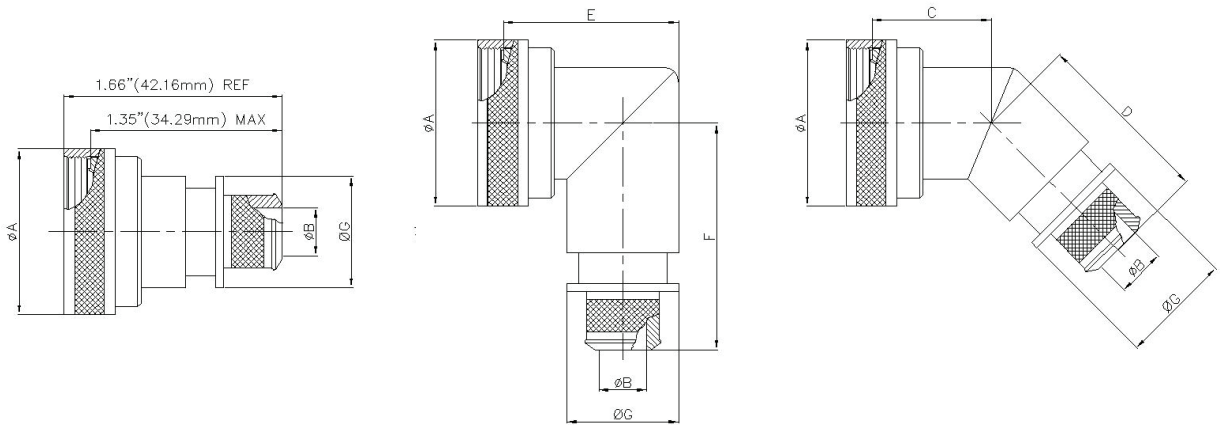

MIL PART NUMBER DESIGNATOR		CONNECTOR SHELL SIZE	A DIA. (MAX)		B DIA. (MAX)		C (MAX)		D (MAX)		E (MAX)		F (MAX.)		G MAX	
ACCESSORY SHELL SIZE	ENTRY SIZE		INCH	MM	+0.00	+0.00	INCH	MM	INCH	MM	INCH	MM	INCH	MM	INCH	MM
					-0.02	-0.50										
08	02	8	0.89	22.48	N/A	N/A	0.87	22.10	1.16	29.46	1.19	30.18	1.42	35.99	N/A	N/A
	03				0.26	6.60									0.56	14.22
10	02	10	1.01	25.65	N/A	N/A	0.89	22.61	1.18	29.97	1.28	32.54	1.48	37.59	N/A	N/A
	03				0.32	8.13									0.63	16.00
12	02	7 / 12	1.14	28.83	0.32	8.13	0.92	23.37	1.20	30.48	1.41	35.71	1.54	39.17	0.63	16.00
	03				0.45	11.43									0.75	19.05
14	02	12 / 14	1.26	32.00	0.45	11.43	0.94	23.88	1.22	30.99	1.53	38.89	1.61	40.77	0.75	19.05
	03				0.57	14.48									0.89	22.61
16	02	19 / 16	1.39	35.18	0.51	12.95	0.96	24.38	1.25	31.75	1.66	42.06	1.67	42.34	0.82	20.83
	03				0.64	16.26									0.95	24.13
18	02	27 / 18	1.51	38.35	0.64	16.26	0.98	24.89	1.26	32.00	1.72	43.64	1.73	43.94	0.95	24.13
	03				0.76	19.30									1.07	27.18
20	02	37 / 20	1.64	41.53	0.64	16.26	1.00	25.40	1.29	32.77	1.84	46.84	1.79	45.52	0.95	24.13
	03				0.82	20.83									1.13	28.07
22	02	22	1.76	44.70	0.70	17.78	1.03	26.16	1.31	33.27	1.94	49.23	1.85	46.99	1.02	25.99
	03				0.95	24.13									1.26	32.00
24	02	24	1.89	47.88	0.76	19.30	1.05	26.67	1.34	34.04	2.09	53.16	1.92	48.69	1.07	27.18
	03				1.01	25.65									1.32	33.53
28	02	28	2.14	54.23	0.89	22.61	1.10	27.94	1.38	35.05	2.53	64.29	2.04	51.87	1.19	30.23
	03				1.14	28.96									1.47	37.34

STRAIGHT; 90° & 45°; SELF-LOCK

38999 Series I & Series II

MIL Part Number

M85049	/85	-10	W	02
Series	Slash Sheet	Shell Size (Table A)	Finish (Table 2, pg. 14)	Entry Size (Table A)
	85: Straight 86: 45° 87: 90°			

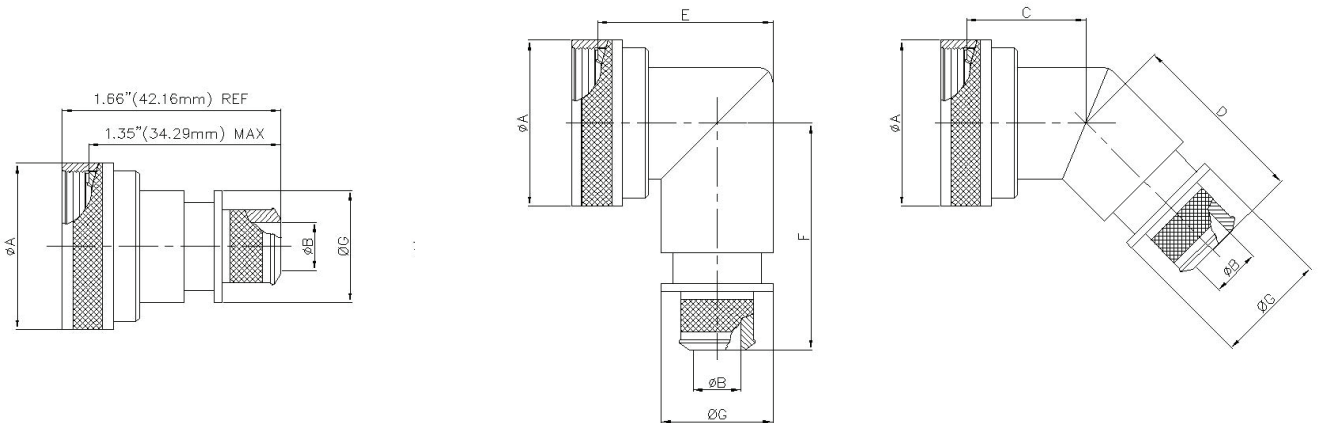

TABLE - A

ACCESSORY SHELLSIZE	M85049/85 ENTRY SIZE	M85049/86 M85049/87 ENTRY SIZE	CONNECTOR SHELL SIZE SE - II/I	ØA(MAX)		ØB		C (MAX)		D (MAX)		E (MAX)		F (MAX)		G (MAX)	
				INCH	MM	+0.00 -0.02	+0.00 -0.50	INCH	MM	INCH	MM	INCH	MM	INCH	MM	INCH	MM
				08	01 02	02 03	8/9	0.86	21.82	N/A 0.26	N/A 6.60	0.87	22.10	1.16	29.46	1.38	34.93
10	01 02	02 03	10/11	0.99	25.04	N/A 0.32	N/A 8.13	0.90	22.86	1.19	30.23	1.44	36.50	1.48	37.59	N/A 0.63	N/A 16.00
12	01 02	02 03	12/13	1.16	29.36	0.32 0.45	8.13 11.43	0.92	23.37	1.21	30.73	1.56	39.67	1.55	39.45	0.63 0.75	16.00 19.05
14	01 02	02 03	14/15	1.28	32.54	0.45 0.57	11.43 14.48	0.95	24.13	1.24	31.50	1.69	42.85	1.61	41.00	0.75 0.89	19.05 22.61
16	01 02	02 03	16/17	1.41	35.71	0.51 0.64	12.95 16.26	0.98	24.89	1.26	32.00	1.75	44.45	1.68	42.62	0.82 0.95	20.83 24.13
18	01 02	02 03	18/19	1.52	38.51	0.64 0.76	16.26 19.30	0.98	24.89	1.27	32.26	1.88	47.63	1.73	44.02	0.95 1.07	24.13 27.18
20	01 02	02 03	20/21	1.64	41.68	0.64 0.82	16.26 20.83	1.01	25.65	1.30	33.02	1.94	49.23	1.80	45.62	0.95 1.13	24.13 28.07
22	01 02	02 03	22/23	1.77	44.86	0.70 0.95	17.78 24.13	1.04	26.42	1.33	33.78	2.06	52.37	1.86	47.22	1.02 1.26	25.99 32.00
24	01 02	02 03	24/25	1.89	48.03	0.76 1.01	19.30 25.65	1.07	27.18	1.35	34.29	2.13	53.98	1.92	48.74	1.07 1.32	27.18 33.53

BAND LOCK ADAPTER

STRAIGHT; 90° & 45°; SELF-LOCK

38999 Series III & Series IV

MIL Part Number

M85049	/88	10	W	02
Series	Slash Sheet	Shell Size (Table A)	Finish (Table 2, pg. 14)	Entry Size (Table A)
	88: Straight 89: 45° 90: 90°			

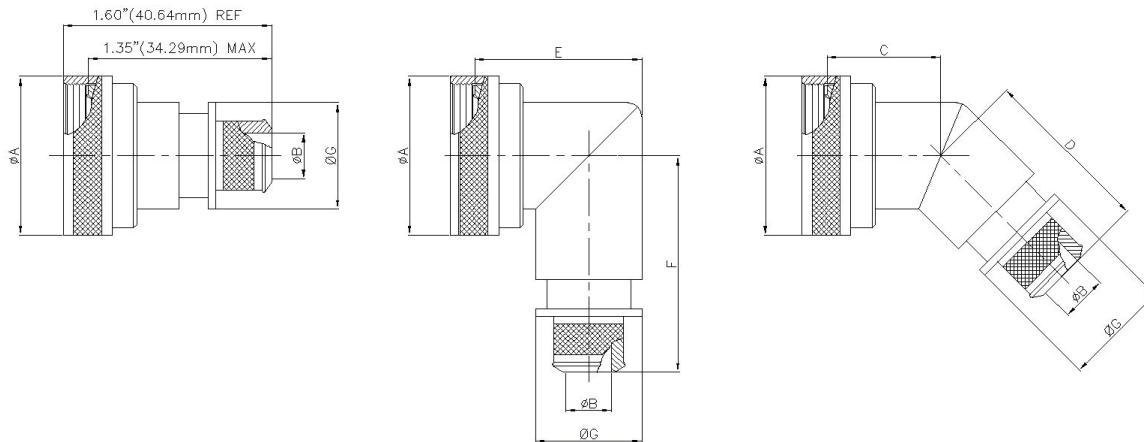

TABLE-A

MIL PART NUMBER DESIGNATOR		CONNECTOR SHELL SIZE/ CODE (REF.)	A DIA. (MAX)		B DIA. (MAX)		C (MAX)		D (MAX)		E (MAX)		F (MAX.)		G MAX	
CONNECTOR SHELL SIZE	ENTRY SIZE		INCH	MM	+0.00	+0.00	INCH	MM	INCH	MM	INCH	MM	INCH	MM	INCH	MM
					-0.02	-0.50										
9	02	09 / A	0.86	21.82	N/A	N/A	1.01	25.65	1.16	29.46	1.38	34.93	1.42	35.99	N/A	N/A
	03				0.26	6.60									0.56	14.22
11	02	11 / B	0.99	25.04	N/A	N/A	1.03	26.16	1.19	30.23	1.44	36.50	1.48	37.59	N/A	N/A
	03				0.32	8.13									0.63	16.00
13	02	13 / C	1.16	29.36	0.32	8.13	1.06	26.92	1.21	30.73	1.56	39.67	1.55	39.45	0.63	16.00
	03				0.45	11.43									0.75	19.05
15	02	15 / D	1.28	32.54	0.45	11.43	1.08	27.43	1.24	31.50	1.69	42.85	1.61	41.00	0.75	19.05
	03				0.57	14.48									0.89	22.61
17	02	17 / E	1.41	35.71	0.51	12.95	1.11	28.19	1.26	32.00	1.75	44.45	1.68	42.62	0.82	20.83
	03				0.64	16.26									0.95	24.13
19	02	19 / F	1.52	38.51	0.64	16.26	1.12	28.45	1.27	32.26	1.88	47.63	1.77	45.03	0.95	24.13
	03				0.76	19.30									1.07	27.18
21	02	21 / G	1.64	41.68	0.64	16.26	1.15	29.21	1.30	33.02	1.94	49.23	1.80	45.62	0.95	24.13
	03				0.82	20.83									1.13	28.07
23	02	23 / H	1.77	44.86	0.70	17.78	1.17	29.72	1.33	33.78	2.06	52.37	1.86	47.22	1.02	25.99
	03				0.95	24.13									1.26	32.00
25	02	25 / J	1.89	48.03	0.76	19.30	1.20	30.48	1.35	34.29	2.13	53.98	1.92	48.74	1.07	27.18
	03				1.01	25.65									1.32	33.53

STRAIGHT; SPIN COUPLING

26482 Series II; 5015 (MS345X); 83723 Series III

MIL Part Number

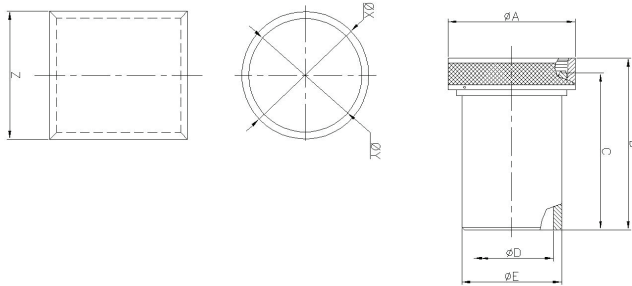

M85049	/26	-1	10	W
Series	Slash Sheet	Shell Size (Table A)	Dash Number (Table A: 26-1 & 26-3) (Table B: 26-2)	Finish (Table 2, pg. 14)
	26: Straight, Spin Coupling			

MIL PART NUMBER DESIGNATOR	CONNECTOR SHELL SIZE	A DIA (MAX)		B (MAX)		C (MAX)		D DIA (MAX)		E DIA. (MAX)	
		INCH	MM	INCH	MM	INCH	MM	INCH	MM	INCH	MM
8	8	0.62	15.67	1.28	32.34	0.96	24.38	0.25	6.35	0.35	8.81
10	10	0.73	18.64	1.28	32.34	0.96	24.38	0.33	8.26	0.50	12.70
12	7/12	0.86	21.79	1.28	32.34	0.96	24.38	0.42	10.67	0.51	12.95
14	12/14	0.98	24.99	1.28	32.34	0.96	24.38	0.54	13.72	0.63	16.00
16	19/16	1.11	28.24	1.28	32.34	0.96	24.38	0.67	17.02	0.76	19.30
18	27/18	1.22	30.94	1.28	32.34	0.96	24.38	0.79	20.04	0.89	22.61
20	37/20	1.35	34.16	1.28	32.34	0.96	24.38	0.91	23.22	1.01	25.65
22	22	1.47	37.29	1.28	32.34	0.96	24.38	1.04	26.39	1.13	28.70
24	24	1.59	40.46	1.28	32.34	0.96	24.38	1.11	28.24	1.20	30.48
28	28	1.97	50.01	1.44	36.55	0.96	24.38	1.39	35.28	1.56	39.62
32	32	2.22	56.36	1.44	36.55	0.96	24.38	1.64	41.53	1.81	45.97
36	36	2.47	62.71	1.44	36.55	0.96	24.38	1.85	46.99	2.06	52.32
40	40	2.72	69.06	1.44	36.55	0.96	24.38	2.07	52.45	2.31	58.67
44	44	2.97	75.41	1.44	36.55	0.96	24.38	2.32	58.93	2.56	65.02
48	48	3.22	81.76	1.44	36.55	0.96	24.38	2.57	65.28	2.81	71.37

MIL PART NUMBER DESIGNATOR		CONNECTOR SHELL SIZE	X DIA				Y DIA				Z	
DASH NO	PART NO COLOR		MIN		MAX		MIN		MAX		INCH	MM
			INCH	MM	INCH	MM	INCH	MM	INCH	MM		
8	GREEN	8	0.45	11.38	0.46	11.63	0.40	10.16	0.41	10.41	0.25	6.35
10	RED	10	0.66	16.76	0.68	17.27	0.59	14.86	0.60	15.11	0.44	11.18
12	RED	7/12	0.66	16.76	0.68	17.27	0.59	14.86	0.60	15.11	0.44	11.18
14	BLUE	12/14	0.78	19.81	0.80	20.32	0.71	17.91	0.72	18.16	0.44	11.18
16	GRAY	19/16	0.91	23.11	0.93	23.62	0.84	21.21	0.85	21.46	0.44	11.18
18	BROWN	27/18	1.08	27.43	1.10	27.94	1.01	25.53	1.02	25.78	0.44	11.18
20	GREEN	37/20	1.20	30.48	1.22	30.99	1.13	28.58	1.14	28.83	0.44	11.18
22	PINK	22	1.32	33.53	1.34	34.04	1.25	31.62	1.26	31.88	0.44	11.18
24	YELLOW	24	1.39	35.23	1.41	35.74	1.31	33.32	1.32	33.58	0.44	11.18
28	RED	28	1.74	44.20	1.76	44.70	1.67	42.29	1.68	42.55	0.44	11.18
32	GRAY	32	1.99	50.55	2.01	51.05	1.92	48.64	1.93	48.90	0.44	11.18
36	GREEN	36	2.24	56.90	2.26	57.40	2.17	54.99	2.18	55.25	0.44	11.18
40	ORANGE	40	2.49	63.25	2.51	63.75	2.42	61.34	2.43	61.60	0.44	11.18
44	YELLOW	44	2.74	69.20	2.76	70.10	2.67	67.69	2.68	67.95	0.44	11.18
48	BLUE	48	2.99	75.95	3.01	76.45	2.92	74.04	2.93	74.30	0.44	11.18

CRIMP RING ADAPTER

STRAIGHT; SPIN COUPLING 38999 Series I & Series II

MIL Part Number

M85049	/33	-2	-10	W
Series	Slash Sheet	Adapter w/o Crimp Ring	Dash Number (Table A)	Finish (Table 2, pg. 14)
	33: Straight			

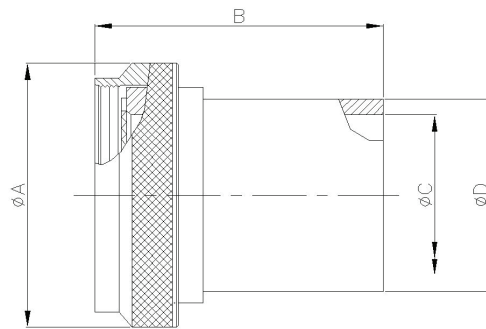

TABLE - A

MIL PART NUMBER DESIGNATOR	CONNECTOR SHELL SIZE SE - II / I	A DIA. (MAX)		B (MAX)		C DIA. (MAX)		D DIA. (MAX)	
		INCH	MM	INCH	MM	INCH	MM	INCH	MM
08	8 / 9	0.75	19.05	1.14	28.96	0.27	6.86	0.35	8.89
10	10 / 11	0.85	21.59	1.14	28.96	0.34	8.64	0.50	12.70
12	12 / 13	1.00	25.40	1.14	28.96	0.44	11.18	0.51	12.95
14	14 / 15	1.10	27.94	1.14	28.96	0.56	14.22	0.63	16.00
16	16 / 17	1.25	31.75	1.14	28.96	0.69	17.53	0.76	19.30
18	18 / 19	1.40	35.56	1.14	28.96	0.80	20.32	0.89	22.61
20	20 / 21	1.50	38.10	1.14	28.96	0.93	23.62	1.01	25.65
22	22 / 23	1.65	41.91	1.14	28.96	1.05	26.67	1.13	28.70
24	24 / 25	1.75	44.45	1.14	28.96	1.13	28.70	1.20	30.48

STRAIGHT; SPIN COUPLING

38999 Series III & Series IV

MIL Part Number

M85049	/20	-11	W
Series	Slash Sheet	Shell Size (Table A)	Finish (Table 2, pg. 14)
	20: Straight		

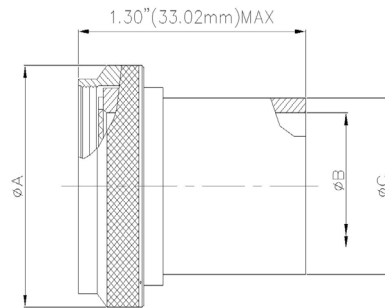

MIL PART NUMBER DESIGNATOR	CONNECTOR SHELL SIZE/ CODE (REF.)	A DIA.(MAX)		B DIA.(MAX)		C DIA.(MAX)	
		INCH	MM	INCH	MM	INCH	MM
9	9 / A	0.75	19.05	0.27	6.73	0.35	8.81
11	11 / B	0.85	21.59	0.34	8.71	0.50	12.65
13	13 / C	1.00	25.40	0.44	11.10	0.51	12.95
15	15 / D	1.10	27.94	0.56	14.27	0.63	16.00
17	17 / E	1.25	31.75	0.69	17.45	0.76	19.30
19	19 / F	1.40	35.56	0.81	20.62	0.89	22.61
21	21 / G	1.50	38.10	0.94	23.80	1.01	25.65
23	23 / H	1.65	41.91	1.05	26.57	1.13	28.70
25	25 / J	1.75	44.45	1.13	28.58	1.20	30.53

MIL-DTL-26482 PROTECTIVE CAPS MS3180

MS3180	10	C	A	L
Designates Plug Dust Cover	Shell Size	Style	Class	Length
	08	C: W/ Chain R: W/O Chain	A: Hard Anodize Black K: Black Zinc Nickel L: Electroless Nickel Plate W: Cadmium Olive Drab	L: 127.0 + 12.7/-6.35 chain/rope in lieu of std. length (Omit for standard length "H")
	10			
	12			
	14			
	16			
	18			
	20			
	22			
24				

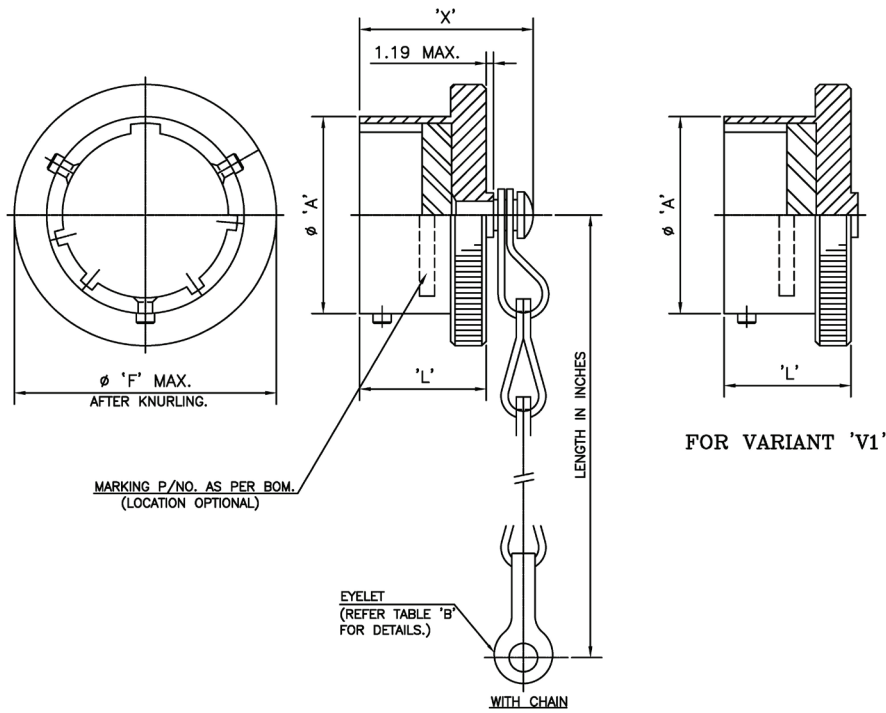

SHELL SIZE	A Ref. +0.03 -0.13	F Max. Overall	H +12.70 -6.35	L Max. Length	X Max. Overall	F +0.00/-0.08 For Heavy Duty
08	12.01	18.26	76.20	14.27	19.84	22.10
10	14.99	21.44				24.86
12	19.05	25.40				29.24
14	22.22	28.58	88.90	15.88	21.44	32.41
16	25.40	31.75				35.58
18	28.58	34.92				38.22
20	31.75	38.10	101.60	16.71	22.22	41.94
22	34.92	41.28				45.11
24	38.10	44.45				48.18

MIL-DTL-26482 PROTECTIVE CAPS MS3181

MS3181	10	C	A	L
Designates Receptacle Dust Cover	Shell Size	Style	Class	Length
	08	C: W/ Chain N: W/ Chain & Ring R: W/O Chain	A: Hard Anodize Black K: Black Zinc Nickel L: Electroless Nickel Plate W: Cadmium Olive Drab	L: 127.0 + 12.7/-6.35 chain/rope in lieu of std. length (Omit for standard length "H")
	10			
	12			
	14			
	16			
	18			
	20			
	22			
24				

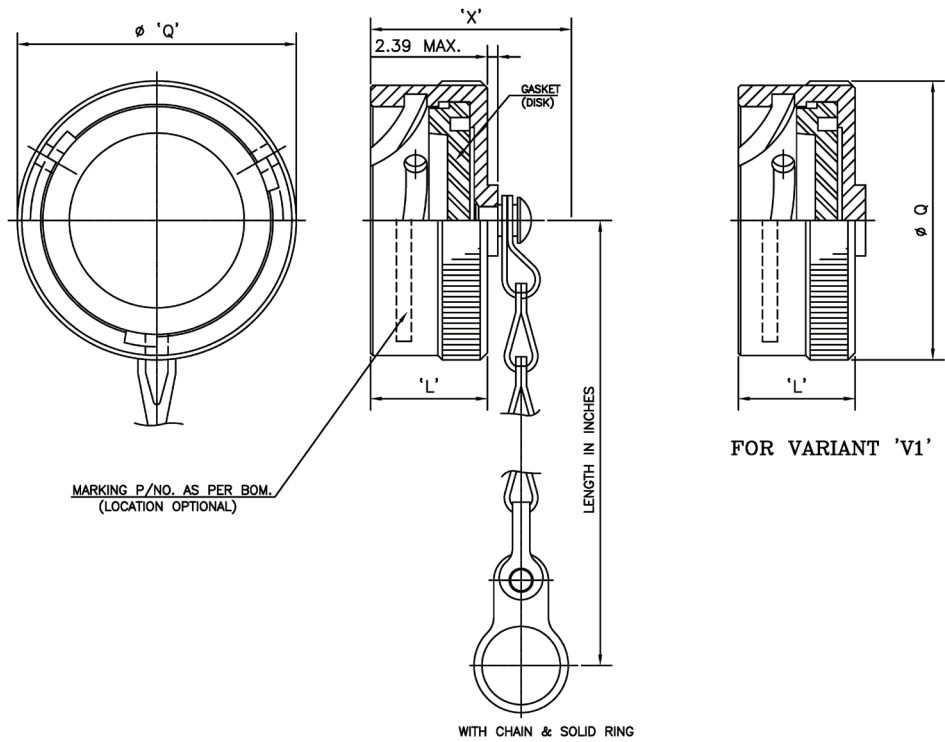

SHELL SIZE	H +12.70/ -6.35	K Max	L Max	N MIN	Q MIN	F Max. Overall
08	76.20	20.62	14.27	14.68	18.64	21.44
10		25.40		17.86	21.82	
12		30.18		22.63	25.40	
14	88.90	88.90		25.81	28.58	
16		39.67		28.98	31.75	
18		42.88		32.16	34.92	
20	101.60	46.02		35.33	38.10	
22		49.23		38.51	41.28	
24		101.60		15.29	41.68	

MIL-DTL-38999 SER I PLUG CAPS

MS27501	11	C	B	L
Designates Plug Dust Cover	Shell Size	Style	Class	Length
	09	C: W/ Chain A: W/O Chain	C: Hard Anodize Black	L: 12.70 + 12.7/6.35 chain
	11		Z: Black Zinc Nickel	M: 152.4 mm chain
	13		F: Electroless Nickel	N: 177.8 inch chain
	15		B: Cadmium Olive Drab	(Omit for standard length "H")
	17			
	19			
	21			
23				
25				

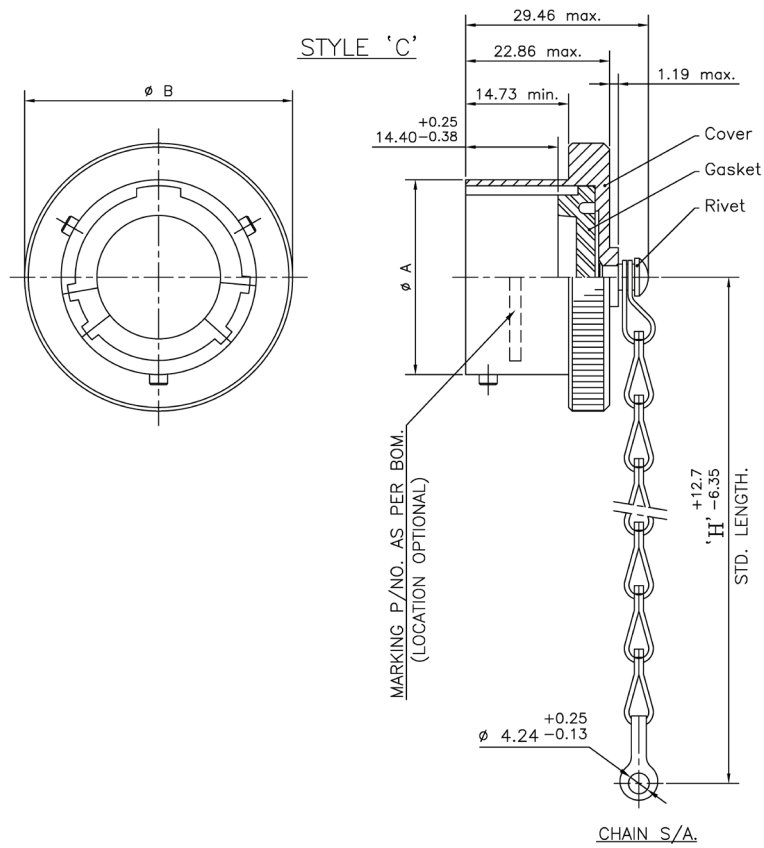

SHELL SIZE	'A' +0.02 -0.13	'B' max	H +12.70/ -6.35
09	14.53	20.83	76.20
11	17.78	23.88	
13	21.59	27.18	
15	24.77	30.23	88.90
17	27.94	33.53	
19	30.66	36.58	
21	33.83	39.88	101.60
23	37.01	42.93	
25	40.18	46.23	

MIL-DTL-38999 SER I RECEPTACLE CAPS

MS27502	11	C	B	L
	Shell Size	Style	Class	Length
Designates Receptacle Dust Cover	09	C: W/ Chain	C: Hard Anodize Black Z: Black Zinc Nickel F: Electroless Nickel B: Cadmium Olive Drab	L- 127.0 + 12.7/-6.35 chain/Rope in lieu of std. length (Omit for standard length "H")
	11			
	13			
	15	N: W/ Chain & Ring		
	17	A: W/O Chain		
	19			
	21			
	23			
25				

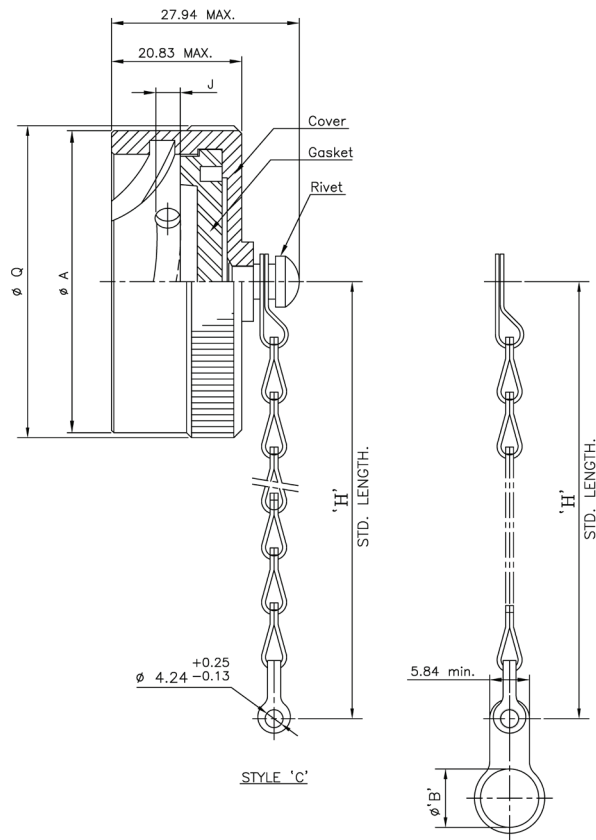

SHELL SIZE	A' Max	B' Min	H +12.70/ -6.35	J +0.38	Q Max
09	20.83	17.78	76.20	2.67	21.84
11	23.88	21.34			24.89
13	27.94	25.65			29.46
15	30.99	28.96	88.90		32.51
17	34.05	32.00			35.81
19	37.08	35.31			38.61
21	40.13	38.35	101.60	41.91	
23	43.18	41.66		44.96	
25	46.48	44.70		48.01	

MIL-DTL-38999 SER II PLUG CAPS

MS27510	08	A	C	L
	Shell Size	Style	Class	Length
Designates Plug Dust Cover	08	C: W/ Chain	C: Hard Anodize Black	L- 127.0 + 12.7/-6.35 chain/Rope in lieu of std. length M: 152.4 N: 177.8 (Omit for standard length "H")
	10		Z: Black Zinc Nickel	
	12		F: Electroless Nickel	
	14		B: Cadmium Olive Drab	
	16	A: W/O Chain		
	18			
	20			
	22			
24				

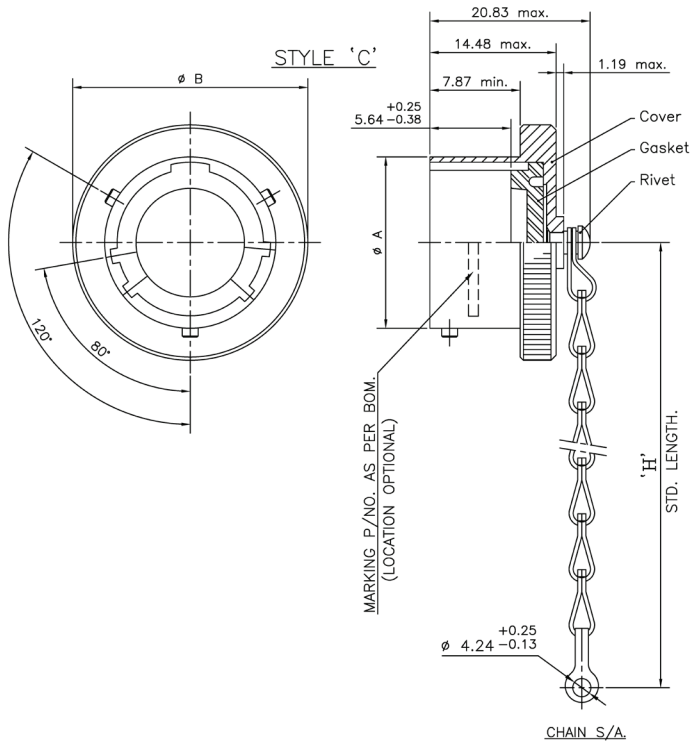

SHELL SIZE	'A' +0.02 -0.13	'B' max	H +12.70/ -6.35
08	12.01	18.29	76.20
10	14.99	21.59	
12	19.05	25.40	
14	22.22	28.70	
16	25.40	31.75	88.90
18	28.58	35.05	
20	31.75	38.10	
22	34.92	41.40	
24	38.10	44.45	101.60

MIL-DTL-38999 SER II RECEPTACLE CAPS

MS27511	10	A	B	L
	Shell Size	Style	Class	Length
Designates Receptacle Dust Cover	08	C: W/ Chain	C: Hard Anodize Black	L- 127.0 + 12.7/-6.35 chain/Rope in lieu of std. length (Omit for standard length "H")
	10			
	12	N: W/ Chain & Ring	Z: Black Zinc Nickel	
	14			
	16	A: W/O Chain	F: Electroless Nickel	
	18	R: S.S Rope hole (3.28 max. 08 to 22 size) (3.68 max. 24 size)	B: Cadmium Olive Drab	
	20			
	22			
24				

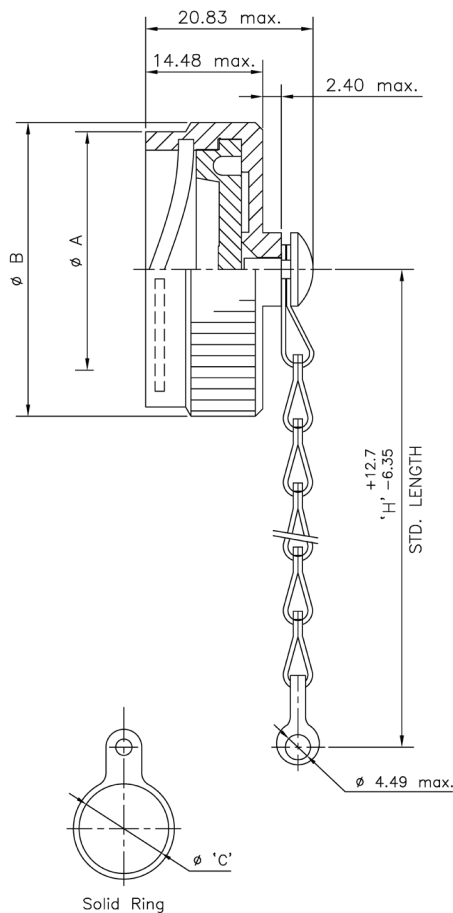

SHELL SIZE	A' Max	B' Max	'C' Min	H
08	16.00	19.05	22.61	76.20
10	19.33	21.82	25.65	
12	23.77	26.19	28.96	88.90
14	27.28	29.36	32.0	
16	29.77	32.54	35.31	
18	33.12	35.71	38.35	101.60
20	36.45	38.89	41.66	
22	39.62	41.68	44.70	
24	42.88	44.86	48.0	

MIL-DTL-38999 SER III PLUG CAPS D38999/32

D38999/32	15	R	W
Designates Plug Dust Cover	Shell Size	Style	Class
	09	N: W/ S.S Rope & Ring R: W/ S.S Rope	W: Aluminum Alloy 500 Hrs. Cadmium Olive Drab Z: Aluminum Alloy 500 Hrs. Black Zinc Nickel F: Aluminum Alloy 48 Hrs. Electroless Nickel
	11		
	13		
	15		
	17		
	19		
	21		
23			
25			

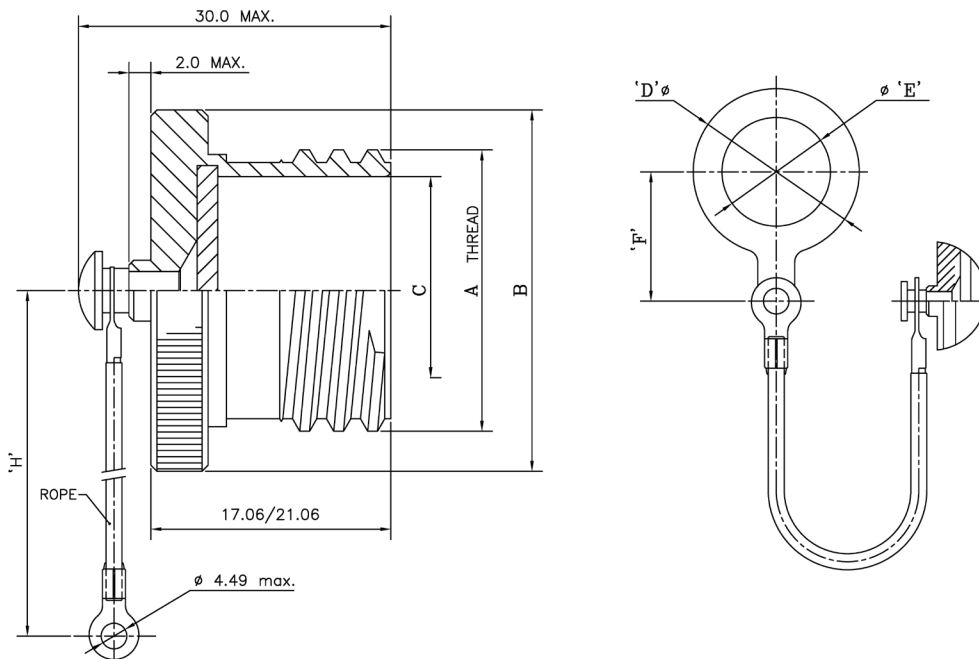

SHELL SIZE	'A' Thread -2A -0.1P -0.3L-TS	'B' Max	'C' +0.0 -0.15	D Max	E Min	'L' +13.0 -7.0
09	0.625"	23.0	12.50	24.0	13.0	127
11	0.750"	26.0	15.75	27.0	18.0	
13	0.875"	31.0	19.53	30.0	20.0	
15	1.000"	33.0	22.71	31.0	23.0	
17	1.1875"	37.0	25.88	37.0	26.0	
19	1.250"	40.0	28.55	40.0	29.0	
21	1.375"	44.0	31.72	44.0	32.0	
23	1.500"	46.0	34.80	46.0	34.0	
25	1.625"	50.0	38.07	49.0	39.0	

MIL-DTL-38999 SER III RECEPTACLE CAPS D38999/33

JAND38999/33	15	R	W
Designates Receptacle Dust Cover	Shell Size	Style	Class
	09	N: W/ S.S Rope & Ring R: W/ S.S Rope	W: Aluminum Alloy 500 Hrs. Cadmium Olive Drab Z: Aluminum Alloy 500 Hrs. Black Zinc Nickel F: Aluminum Alloy 48 Hrs. Electroless Nickel
	11		
	13		
	15		
	17		
	19		
	21		
23			
25			

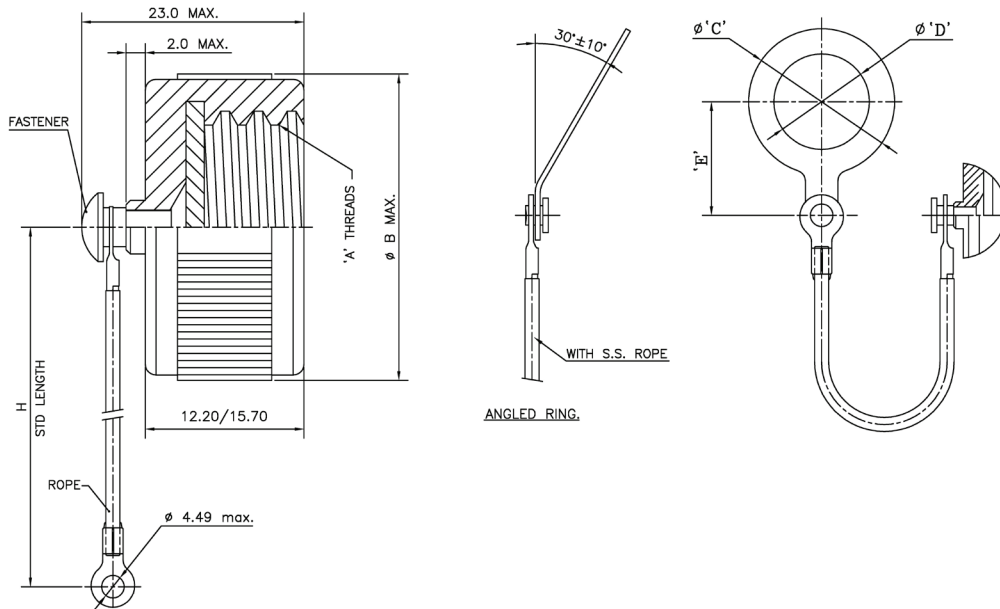

SHELL SIZE	'A' Thread -2A-0.1P -0.3L-TS	'B' Max	'C' +0.0 -0.15	D Min	'L' + 13.0 - 7.0
09	0.625"	23.0	27.0	17.64	127
11	0.750"	28.0	32.0	21.97	
13	0.875"	31.0	37.0	25.12	
15	1.000"	32.0	40.0	29.92	
17	1.1875"	37.0	44.0	32.0	
19	1.250"	39.0	46.0	36.27	
21	1.375"	42.0	49.0	38.25	
23	1.500"	45.0	54.0	42.62	
25	1.625"	49.0	56.0	44.45	

STRAIGHT, SPIN COUPLING 26482 Series II; 5015 (MS345X); 83723 Series III

MIL Part Number

M85049	/11	-10	W
Series	Slash Sheet	Dash Number (Table A)	Finish (Table 2, pg. 14)
	11: Straight, Spin Coupling		

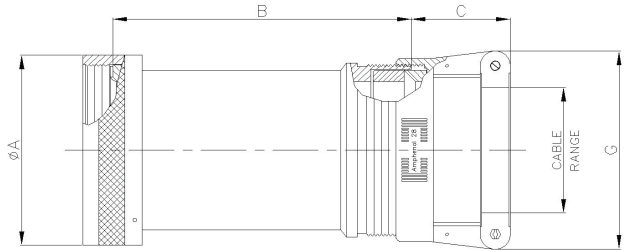

MIL PART NUMBER DESIGNATOR		CONNECTOR SHELL SIZE	ADIA. (MAX)		B (MAX)		C (REF) L MAX		G (MAX) L MAX		CABLE RANGE			
			INCH	MM	INCH	MM	INCH	MM	INCH	MM	MIN WIRE		MAX WIRE	
SHELL SIZE	DASH NO										INCH	MM	INCH	MM
08	05	8	0.62	15.67	2.13	54.10	1.03	26.09	0.96	24.31	0.13	3.18	0.25	6.35
	06		0.62	15.67	3.13	79.50	1.03	26.09	0.96	24.31	0.13	3.18	0.25	6.35
	07*		0.62	15.67	2.88	73.15	1.03	26.09	1.15	29.08	0.25	6.35	0.44	11.10
	08*		0.62	15.67	3.88	98.55	1.03	26.09	1.15	29.08	0.25	6.35	0.44	11.10
10	09	10	0.73	18.64	2.13	54.10	1.03	26.09	0.96	24.31	0.13	3.18	0.31	7.92
	10		0.73	18.64	3.13	79.50	1.03	26.09	0.96	24.31	0.13	3.18	0.31	7.92
	11*		0.73	18.64	2.88	73.15	1.03	26.09	1.15	29.08	0.25	6.35	0.44	11.10
	12*		0.73	18.64	3.88	98.55	1.03	26.09	1.15	29.08	0.25	6.35	0.44	11.10
	136		0.73	18.64	2.13	54.10	1.03	26.09	1.15	29.08	0.25	6.35	0.38	9.53
137	0.73	18.64	3.13	79.50	1.03	26.09	1.15	29.08	0.25	6.35	0.38	9.53		
12	13	7/12	0.86	21.79	2.13	54.10	1.03	26.09	1.15	29.08	0.25	6.35	0.44	11.10
	14		0.86	21.79	3.13	79.50	1.03	26.09	1.15	29.08	0.25	6.35	0.44	11.10
	15*		0.86	21.79	2.88	73.15	1.03	26.09	1.33	33.83	0.35	8.89	0.63	15.88
	16*		0.86	21.79	3.88	98.55	1.03	26.09	1.33	33.83	0.35	8.89	0.63	15.88
	111		0.86	21.79	2.13	54.10	1.03	26.09	1.33	33.83	0.35	8.89	0.50	12.70
	114		0.86	21.79	2.13	54.10	1.03	26.09	0.96	24.31	0.13	3.18	0.31	7.92
	115		0.86	21.79	3.13	79.50	1.03	26.09	0.96	24.31	0.13	3.18	0.31	7.92
	138		0.86	21.79	2.13	54.10	1.03	26.09	1.33	33.83	0.35	8.89	0.50	12.70
139	0.86	21.79	3.13	79.50	1.03	26.09	1.33	33.83	0.35	8.89	0.50	12.70		
14	17	12/14	0.98	24.99	2.13	54.10	1.03	26.09	1.33	33.83	0.35	8.89	0.58	14.61
	18		0.98	24.99	3.13	79.50	1.03	26.09	1.33	33.83	0.35	8.89	0.58	14.61
	19*		0.98	24.99	2.88	73.15	1.06	26.90	1.55	39.40	0.50	12.70	0.75	19.05
	20*		0.98	24.99	3.88	98.55	1.06	26.90	1.55	39.40	0.50	12.70	0.75	19.05
	116		0.98	24.99	2.13	54.10	1.03	26.09	1.15	29.08	0.25	6.35	0.44	11.10
	117		0.98	24.99	3.13	79.50	1.03	26.09	1.15	29.08	0.25	6.35	0.44	11.10
	150		0.98	24.99	2.13	54.10	1.03	26.09	0.96	24.31	0.13	3.18	0.31	7.92
	151		0.98	24.99	3.13	79.50	1.03	26.09	0.96	24.31	0.13	3.18	0.31	7.92
16	21	19/16	1.11	28.24	2.13	54.10	1.06	26.90	1.55	39.40	0.50	12.70	0.70	17.78
	22		1.11	28.24	3.13	79.50	1.06	26.90	1.55	39.40	0.50	12.70	0.70	17.78
	23*		1.11	28.24	2.88	73.15	1.16	29.36	1.77	44.96	0.63	15.88	0.94	23.80
	24*		1.11	28.24	3.88	98.55	1.16	29.36	1.77	44.96	0.63	15.88	0.94	23.80
	112		1.11	28.24	2.13	54.10	1.03	26.09	1.15	29.08	0.25	6.35	0.44	11.10
	113		1.11	28.24	3.13	79.50	1.03	26.09	1.15	29.08	0.25	6.35	0.44	11.10

Table continued

STRAIGHT, SPIN COUPLING

26482 Series II; 5015 (MS345X); 83723 Series III

MIL PART NUMBER DESIGNATOR		CONNECTOR SHELL SIZE	TABLE - A											
			ADIA. (MAX)		B (MAX)		C (REF) L MAX		G (MAX) L MAX		CABLE RANGE			
			INCH	MM	INCH	MM	INCH	MM	INCH	MM	MIN WIRE		MAX WIRE	
SHELL SIZE	DASH NO									INCH	MM	INCH	MM	
16, cont.	118	19/16	1.11	28.24	2.13	54.10	1.03	26.09	1.33	33.83	0.35	8.89	0.63	15.88
	119		1.11	28.24	3.13	79.50	1.03	26.09	1.33	33.83	0.35	8.89	0.63	15.88
	152		1.11	28.24	2.13	54.10	1.03	26.09	0.96	24.31	0.13	3.18	0.31	7.92
	153		1.11	28.24	3.13	79.50	1.03	26.09	0.96	24.31	0.13	3.18	0.31	7.92
18	25	27/18	1.22	30.94	2.13	54.10	1.03	26.09	1.33	33.83	0.35	8.89	0.63	15.88
	26		1.22	30.94	3.13	79.50	1.03	26.09	1.33	33.83	0.35	8.89	0.63	15.88
	27		1.22	30.94	2.13	54.10	1.06	26.90	1.55	39.40	0.50	12.70	0.75	19.05
	28		1.22	30.94	3.13	79.50	1.06	26.90	1.55	39.40	0.50	12.70	0.75	19.05
	29*		1.22	30.94	2.88	73.15	1.16	29.36	1.77	44.96	0.63	15.88	0.94	23.80
	30*		1.22	30.94	3.88	98.55	1.16	29.36	1.77	44.96	0.63	15.88	0.94	23.80
	120		1.22	30.94	2.13	54.10	1.03	26.09	0.96	24.31	0.13	3.18	0.31	7.92
	121		1.22	30.94	3.13	79.50	1.03	26.09	0.96	24.31	0.13	3.18	0.31	7.92
	122		1.22	30.94	2.13	54.10	1.03	26.09	1.15	29.08	0.25	6.35	0.44	11.10
	123		1.22	30.94	3.13	79.50	1.03	26.09	1.15	29.08	0.25	6.35	0.44	11.10
20	31	37/20	1.35	34.16	3.13	79.50	1.03	26.09	1.33	33.83	0.35	8.89	0.63	15.88
	32		1.35	34.16	4.13	104.90	1.03	26.09	1.33	33.83	0.35	8.89	0.63	15.88
	33		1.35	34.16	3.13	79.50	1.06	26.90	1.55	39.40	0.50	12.70	0.75	19.05
	34		1.35	34.16	4.13	104.90	1.06	26.90	1.55	39.40	0.50	12.70	0.75	19.05
	35*		1.35	34.16	3.88	98.55	1.16	29.36	1.77	44.96	0.63	15.88	0.94	23.80
	36*		1.35	34.16	4.88	123.95	1.16	29.36	1.77	44.96	0.63	15.88	0.94	23.80
	37*		1.35	34.16	3.88	98.55	1.38	34.93	2.11	53.67	0.88	22.23	1.25	31.75
	38*		1.35	34.16	4.88	123.95	1.38	34.93	2.11	53.67	0.88	22.23	1.25	31.75
	124		1.35	34.16	3.13	79.50	1.03	26.09	1.15	29.08	0.25	6.35	0.44	11.10
	125		1.35	34.16	4.13	104.90	1.03	26.09	1.15	29.08	0.25	6.35	0.44	11.10
	140		1.35	34.16	3.13	79.50	1.16	29.36	1.77	44.96	0.63	15.88	0.90	22.96
	141		1.35	34.16	4.13	104.90	1.16	29.36	1.77	44.96	0.63	15.88	0.90	22.96
	22		39	22	1.47	37.29	3.13	79.50	1.03	26.09	1.33	33.83	0.35	8.89
40		1.47	37.29		4.13	104.90	1.03	26.09	1.33	33.83	0.35	8.89	0.63	15.88
41		1.47	37.29		3.13	79.50	1.06	26.90	1.55	39.40	0.50	12.70	0.75	19.05
42		1.47	37.29		4.13	104.90	1.06	26.90	1.55	39.40	0.50	12.70	0.75	19.05
43		1.47	37.29		3.13	79.50	1.16	29.36	1.77	44.96	0.63	15.88	0.94	23.80
44		1.47	37.29		4.13	104.90	1.16	29.36	1.77	44.96	0.63	15.88	0.94	23.80
45*		1.47	37.29		3.88	98.55	1.38	34.93	2.11	53.67	0.88	22.23	1.25	31.75
46*		1.47	37.29		4.88	123.95	1.38	34.93	2.11	53.67	0.88	22.23	1.25	31.75
126		1.47	37.29		3.13	79.50	1.03	26.09	0.96	24.31	0.13	3.18	0.31	7.92
127		1.47	37.29		4.13	104.90	1.03	26.09	0.96	24.31	0.13	3.18	0.31	7.92
128		1.47	37.29		3.13	79.50	1.03	26.09	1.15	29.08	0.25	6.35	0.44	11.10
129		1.47	37.29		4.13	104.90	1.03	26.09	1.15	29.08	0.25	6.35	0.44	11.10
142		1.47	37.29		3.13	79.50	1.38	34.93	2.11	53.67	0.88	22.23	1.03	26.14
143		1.47	37.29		4.13	104.90	1.38	34.93	2.11	53.67	0.88	22.23	1.03	26.14
24	47	24	1.59	40.46	3.13	79.50	1.06	26.90	1.55	39.40	0.50	12.70	0.75	19.05
	48		1.59	40.46	4.13	104.90	1.06	26.90	1.55	39.40	0.50	12.70	0.75	19.05
	49		1.59	40.46	3.13	79.50	1.16	29.36	1.77	44.96	0.63	15.88	0.81	20.62
	50		1.59	40.46	4.13	104.90	1.16	29.36	1.77	44.96	0.63	15.88	0.81	20.62
	51		1.59	40.46	3.13	79.50	1.16	29.36	1.77	44.96	0.63	15.88	0.94	23.80
	52		1.59	40.46	4.13	104.90	1.16	29.36	1.77	44.96	0.63	15.88	0.94	23.80
	53*		1.59	40.46	3.88	98.55	1.38	34.93	2.11	53.67	0.88	22.23	1.25	31.75
	54*		1.59	40.46	4.88	123.95	1.38	34.93	2.11	53.67	0.88	22.23	1.25	31.75
	130		1.59	40.46	3.13	79.50	1.03	26.09	1.33	33.83	0.35	8.89	0.63	15.88
	131		1.59	40.46	4.13	104.90	1.03	26.09	1.33	33.83	0.35	8.89	0.63	15.88
	144		1.59	40.46	3.13	79.50	1.38	34.93	2.11	53.67	0.88	22.23	1.14	29.06
145	1.59	40.46	4.13	104.90	1.38	34.93	2.11	53.67	0.88	22.23	1.14	29.06		
28	55	28	1.97	50.01	3.13	79.50	1.06	26.90	1.55	39.40	0.50	12.70	0.75	19.05
	56		1.97	50.01	4.13	104.90	1.06	26.90	1.55	39.40	0.50	12.70	0.75	19.05
	57		1.97	50.01	3.13	79.50	1.16	29.36	1.77	44.96	0.63	15.88	0.94	23.80
	58		1.97	50.01	4.13	104.90	1.16	29.36	1.77	44.96	0.63	15.88	0.94	23.80

Table continued
 (*)Denotes Style- 2

STRAIGHT, SPIN COUPLING

26482 Series II; 5015 (MS345X); 83723 Series III

MIL PART NUMBER DESIGNATOR		CONNECTOR SHELL SIZE	TABLE - A											
			A DIA. (MAX)		B (MAX)		C (REF) L MAX		G (MAX) L MAX		CABLE RANGE			
			INCH	MM	INCH	MM	INCH	MM	INCH	MM	MIN WIRE		MAX WIRE	
SHELL SIZE	DASH NO									INCH	MM	INCH	MM	
28, cont.	59	28	1.97	50.01	3.13	79.50	1.38	34.93	2.11	53.67	0.88	22.23	1.25	31.75
	60		1.97	50.01	4.13	104.90	1.38	34.93	2.11	53.67	0.88	22.23	1.25	31.75
	61		1.97	50.01	3.13	79.50	1.50	38.10	2.36	60.02	1.00	25.40	1.38	34.93
	62		1.97	50.01	4.13	104.90	1.50	38.10	2.36	60.02	1.00	25.40	1.38	34.93
32	63	32	2.22	56.36	3.13	79.50	1.16	29.36	1.77	44.96	0.63	15.88	0.94	23.80
	64		2.22	56.36	4.13	104.90	1.16	29.36	1.77	44.96	0.63	15.88	0.94	23.80
	65		2.22	56.36	3.13	79.50	1.38	34.93	2.11	53.67	0.88	22.23	1.25	31.75
	66		2.22	56.36	4.13	104.90	1.38	34.93	2.11	53.67	0.88	22.23	1.25	31.75
	67		2.22	56.36	3.13	79.50	1.50	38.10	2.36	60.02	1.00	25.40	1.38	34.93
	68		2.22	56.36	4.13	104.90	1.50	38.10	2.36	60.02	1.00	25.40	1.38	34.93
	69		2.22	56.36	3.13	79.50	1.78	45.24	2.77	70.36	1.25	31.75	1.63	41.28
	70		2.22	56.36	4.13	104.90	1.78	45.24	2.77	70.36	1.25	31.75	1.63	41.28
36	71	36	2.47	62.71	4.13	104.90	1.38	34.93	2.11	53.67	0.88	22.23	1.25	31.75
	72		2.47	62.71	5.13	130.30	1.38	34.93	2.11	53.67	0.88	22.23	1.25	31.75
	73		2.47	62.71	4.13	104.90	1.50	38.10	2.36	60.02	1.00	25.40	1.38	34.93
	74		2.47	62.71	5.13	130.30	1.50	38.10	2.36	60.02	1.00	25.40	1.38	34.93
	75		2.47	62.71	4.13	104.90	1.78	45.24	2.77	70.36	1.25	31.75	1.63	41.28
	76		2.47	62.71	5.13	130.30	1.78	45.24	2.77	70.36	1.25	31.75	1.63	41.28
	77*		2.47	62.71	5.01	127.25	1.83	46.48	3.02	76.71	1.44	36.50	1.88	47.63
	78*		2.47	62.71	6.01	152.65	1.83	46.48	3.02	76.71	1.44	36.50	1.88	47.63
	132		2.47	62.71	4.13	104.90	1.06	26.90	1.55	39.40	0.50	12.70	0.75	19.05
	133		2.47	62.71	5.13	130.30	1.06	26.90	1.55	39.40	0.50	12.70	0.75	19.05
	146		2.47	62.71	4.13	104.90	1.83	46.48	3.02	76.71	1.44	36.50	1.84	46.74
	147		2.47	62.71	5.13	130.30	1.83	46.48	3.02	76.71	1.44	36.50	1.84	46.74
	148		2.47	62.71	4.13	104.90	1.16	29.36	1.77	44.96	0.63	15.88	0.94	23.80
	149		2.47	62.71	5.13	130.30	1.16	29.36	1.77	44.96	0.63	15.88	0.94	23.80
40	79	40	2.72	69.06	4.13	104.90	1.38	34.93	2.11	53.67	0.88	22.23	1.25	31.75
	80		2.72	69.06	5.13	130.30	1.38	34.93	2.11	53.67	0.88	22.23	1.25	31.75
	81		2.72	69.06	4.13	104.90	1.50	38.10	2.36	60.02	1.00	25.40	1.38	34.93
	82		2.72	69.06	5.13	130.30	1.50	38.10	2.36	60.02	1.00	25.40	1.38	34.93
	83		2.72	69.06	4.13	104.90	1.78	45.24	2.77	70.36	1.25	31.75	1.63	41.28
	84		2.72	69.06	5.13	130.30	1.78	45.24	2.77	70.36	1.25	31.75	1.63	41.28
	85		2.72	69.06	4.13	104.90	1.83	46.48	3.02	76.71	1.44	36.50	1.88	47.63
	86		2.72	69.06	5.13	130.30	1.83	46.48	3.02	76.71	1.44	36.50	1.88	47.63
	134		2.72	69.06	4.13	104.90	1.06	26.90	1.55	39.40	0.50	12.70	0.75	19.05
	135		2.72	69.06	5.13	130.30	1.06	26.90	1.55	39.40	0.50	12.70	0.75	19.05
	156		2.72	69.06	4.13	104.90	1.16	29.36	1.77	44.96	0.63	15.88	0.94	23.80
	157		2.72	69.06	5.13	130.30	1.16	29.36	1.77	44.96	0.63	15.88	0.94	23.80
44	87	44	2.97	75.41	4.13	104.90	1.38	34.93	2.11	53.67	0.88	22.23	1.25	31.75
	88		2.97	75.41	5.13	130.30	1.38	34.93	2.11	53.67	0.88	22.23	1.25	31.75
	89		2.97	75.41	4.13	104.90	1.50	38.10	2.36	60.02	1.00	25.40	1.38	34.93
	90		2.97	75.41	5.13	130.30	1.50	38.10	2.36	60.02	1.00	25.40	1.38	34.93
	91		2.97	75.41	4.13	104.90	1.78	45.24	2.77	70.36	1.25	31.75	1.63	41.28
	92		2.97	75.41	5.13	130.30	1.78	45.24	2.77	70.36	1.25	31.75	1.63	41.28
	93		2.97	75.41	4.13	104.90	1.83	46.48	3.02	76.71	1.44	36.50	1.88	47.63
	94		2.97	75.41	5.13	130.30	1.83	46.48	3.02	76.71	1.44	36.50	1.88	47.63
	154		2.97	75.41	4.13	104.90	1.16	29.36	1.77	44.96	0.63	15.88	0.94	23.80
	155		2.97	75.41	5.13	130.30	1.16	29.36	1.77	44.96	0.63	15.88	0.94	23.80
48	95	48	3.22	81.76	4.13	104.90	1.38	34.93	2.11	53.67	0.88	22.23	1.25	31.75
	96		3.22	81.76	5.13	130.30	1.38	34.93	2.11	53.67	0.88	22.23	1.25	31.75
	97		3.22	81.76	4.13	104.90	1.50	38.10	2.36	60.02	1.00	25.40	1.38	34.93
	98		3.22	81.76	5.13	130.30	1.50	38.10	2.36	60.02	1.00	25.40	1.38	34.93
	99		3.22	81.76	4.13	104.90	1.78	45.24	2.77	70.36	1.25	31.75	1.63	41.28
	100		3.22	81.76	5.13	130.30	1.78	45.24	2.77	70.36	1.25	31.75	1.63	41.28
	101		3.22	81.76	4.13	104.90	1.83	46.48	3.02	76.71	1.44	36.50	1.88	47.63
	102		3.22	81.76	5.13	130.30	1.83	46.48	3.02	76.71	1.44	36.50	1.88	47.63

90° & 45°; SPIN COUPLING

26482 Series II; 5015 (MS345X); 83723 Series III

MIL Part Number

M85049	/9	-10	W
Series	Slash Sheet	Dash Number (Table A)	Finish (Table 2, pg. 14)
	9: 90° 7: 45°		

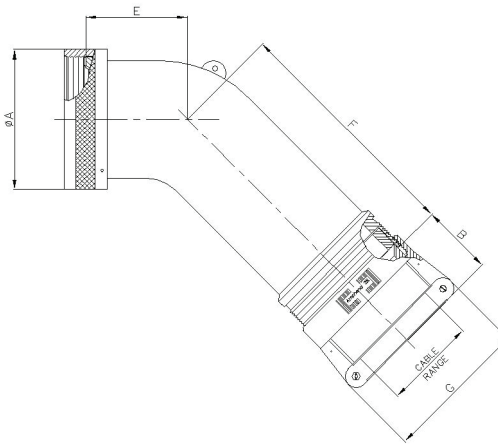

TABLE - A

MIL PART NUMBER DESIGNATOR		CONNECTOR SHELL SIZE	A DIA. (MAX)		B (REF)		C (MAX)		D (MAX)		E (MAX)		F (MAX)		G (MAX)		CABLE RANGE			
			INCH	MM	INCH	MM	INCH	MM	INCH	MM	INCH	MM	INCH	MM	INCH	MM	MIN WIRE	MAX WIRE	INCH	MM
08	3	8	0.62	15.67	1.03	26.09	0.67	17.02	1.26	32.00	0.63	16.00	1.25	31.75	0.96	24.31	0.13	3.18	0.25	6.35
	4		0.73	18.64	1.03	26.09	0.76	19.30	1.98	50.29	0.69	17.53	1.92	48.77	0.96	24.31	0.13	3.18	0.31	7.92
10	49*	10	0.73	18.64	1.03	26.09	1.52	38.61	2.00	50.80	1.50	38.10	1.98	50.29	1.15	29.08	0.25	6.35	0.44	11.10
	5		0.73	18.64	1.03	26.09	0.76	19.30	1.38	35.05	0.69	17.53	1.31	33.27	1.15	29.08	0.25	6.35	0.38	9.53
12	6	7/12	0.86	21.79	1.03	26.09	0.77	19.56	2.00	50.80	0.75	19.05	1.98	50.29	0.96	24.31	0.13	3.18	0.31	7.92
	71*		0.86	21.79	1.03	26.09	1.81	45.97	2.16	54.86	1.65	41.91	2.18	55.37	1.33	33.83	0.35	8.89	0.63	15.88
	7		0.86	21.79	1.03	26.09	0.77	19.56	2.00	50.80	0.75	19.05	1.98	50.29	1.15	29.08	0.25	6.35	0.44	11.10
14	8	12/14	0.86	21.79	1.03	26.09	0.77	19.56	1.40	35.56	0.75	19.05	1.98	50.29	1.33	33.83	0.35	8.89	0.50	12.70
	9		0.98	24.99	1.03	26.09	0.87	22.10	2.07	52.58	0.81	20.57	2.07	52.58	1.15	29.08	0.25	6.35	0.44	11.10
	10		0.98	24.99	1.03	26.09	0.87	22.10	1.72	43.69	0.81	20.57	1.72	43.69	1.33	33.83	0.35	8.89	0.58	14.61
	50*		0.98	24.99	1.06	26.90	1.89	48.01	2.33	59.18	1.84	46.74	2.37	60.20	1.55	39.40	0.50	12.70	0.75	19.05
16	74	19/16	0.98	24.99	1.03	26.09	0.87	22.10	2.07	52.58	0.81	20.57	2.07	52.58	0.96	24.31	0.13	3.18	0.31	7.92
	11		1.11	28.24	1.03	26.09	1.05	26.67	2.16	54.86	0.91	23.11	2.18	55.37	1.15	29.08	0.25	6.35	0.44	11.10
	12		1.11	28.24	1.06	26.90	1.05	26.67	1.81	45.97	0.91	23.11	1.82	46.23	1.55	39.40	0.50	12.70	0.70	17.78
	40		1.11	28.24	1.03	26.09	1.05	26.67	2.16	54.86	0.91	23.11	2.18	55.37	1.33	33.83	0.35	8.89	0.63	15.88
	51*		1.11	28.24	1.16	29.36	2.04	51.82	2.44	61.98	1.94	49.28	2.52	64.01	1.77	44.96	0.63	15.88	0.94	23.80
75	1.11	28.24	1.03	26.09	1.05	26.67	2.16	54.86	0.91	23.11	2.18	55.37	0.96	24.31	0.13	3.18	0.31	7.92		

(*)Denotes Style- 2
Table continued

90° & 45°; SPIN COUPLING
26482 Series II; 5015 (MS345X); 83723 Series III

MIL PART NUMBER DESIGNATOR		CONNECTOR SHELL SIZE	TABLE A																CABLE RANGE			
			ADIA. (MAX)		B (REF)		C (MAX)		D (MAX)		E (MAX)		F (MAX)		G (MAX)		MIN WIRE		MAX WIRE			
			INCH	MM	INCH	MM	INCH	MM	INCH	MM	INCH	MM	INCH	MM	INCH	MM	INCH	MM	INCH	MM		
18	13	27/18	1.22	30.94	1.03	26.09	1.14	28.96	2.33	59.18	1.09	27.69	2.37	60.20	1.33	33.83	0.35	8.89	0.63	15.88		
	14		1.22	30.94	1.16	29.36	1.14	28.96	1.98	50.29	1.09	27.69	2.00	50.80	1.77	44.96	0.63	15.88	0.78	19.79		
	41		1.22	30.94	1.03	26.09	1.14	28.96	2.33	59.18	1.09	27.69	2.37	60.20	0.96	24.31	0.13	3.18	0.31	7.92		
	42		1.22	30.94	1.03	26.09	1.14	28.96	2.33	59.18	1.09	27.69	2.37	60.20	1.15	29.08	0.25	6.35	0.44	11.10		
	52		1.22	30.94	1.06	26.90	1.14	28.96	2.33	59.18	1.09	27.69	2.37	60.20	1.55	39.40	0.50	12.70	0.75	19.05		
72*	1.22	30.94	1.16	29.36	2.05	52.07	2.44	61.98	1.94	49.28	2.52	64.01	1.77	44.96	0.63	15.88	0.94	23.80				
20	15	37/20	1.35	34.16	1.03	26.09	1.14	28.96	2.33	59.18	1.09	27.69	2.37	60.20	1.33	33.83	0.35	8.89	0.63	15.88		
	16		1.35	34.16	1.16	29.36	1.14	28.96	1.98	50.29	1.09	27.69	2.00	50.80	1.77	44.96	0.63	15.88	0.90	22.96		
	43		1.35	34.16	1.03	26.09	1.14	28.96	2.33	59.18	1.09	27.69	2.37	60.20	1.15	29.08	0.25	6.35	0.44	11.10		
	54		1.35	34.16	1.06	26.90	1.14	28.96	2.33	59.18	1.09	27.69	2.37	60.20	1.55	39.40	0.50	12.70	0.75	19.05		
	55		1.35	34.16	1.38	34.93	2.14	54.36	2.61	66.29	2.06	52.32	2.57	65.28	2.11	53.67	0.88	22.23	1.25	31.75		
22	17	22	1.47	37.29	1.06	26.90	1.29	32.77	2.44	61.98	1.19	30.23	2.52	64.01	1.55	39.40	0.50	12.70	0.75	19.05		
	18		1.47	37.29	1.38	34.93	1.29	32.77	2.09	53.09	1.19	30.23	2.16	54.86	2.11	53.67	0.88	22.23	1.03	26.14		
	44		1.47	37.29	1.03	26.09	1.29	32.77	2.44	61.98	1.19	30.23	2.52	64.01	0.96	24.31	0.13	3.18	0.31	7.92		
	45		1.47	37.29	1.03	26.09	1.29	32.77	2.44	61.98	1.19	30.23	2.52	64.01	1.15	29.08	0.25	6.35	0.44	11.10		
	56		1.47	37.29	1.03	26.09	1.29	32.77	2.44	61.98	1.19	30.23	2.52	64.01	1.33	33.83	0.35	8.89	0.63	15.88		
	57		1.47	37.29	1.16	29.36	1.29	32.77	2.44	61.98	1.19	30.23	2.52	64.01	1.77	44.96	0.63	15.88	0.94	23.80		
	58*		1.47	37.29	1.38	34.93	2.14	54.36	2.61	66.29	2.06	52.32	2.57	65.28	2.11	53.67	0.88	22.23	1.25	31.75		
24	19	24	1.59	40.46	1.06	26.90	1.29	32.77	2.44	61.98	1.19	30.23	2.52	64.01	1.55	39.40	0.50	12.70	0.75	19.05		
	20		1.59	40.46	1.38	34.93	1.29	32.77	2.09	53.09	1.19	30.23	2.16	54.86	2.11	53.67	0.88	22.23	1.14	29.06		
	46		1.59	40.46	1.03	26.09	1.29	32.77	2.44	61.98	1.19	30.23	2.52	64.01	1.33	33.83	0.35	8.89	0.63	15.88		
	59		1.59	40.46	1.16	29.36	1.29	32.77	2.44	61.98	1.19	30.23	2.52	64.01	1.77	44.96	0.63	15.88	0.94	23.80		
	73*		1.59	40.46	1.38	34.93	2.15	54.61	2.61	66.29	2.06	52.32	2.57	65.28	2.12	53.75	0.88	22.23	1.25	31.75		
28	21	28	1.97	50.01	1.16	29.36	1.39	35.31	2.61	66.29	1.31	33.27	2.57	65.28	1.77	44.96	0.63	15.88	0.94	23.80		
	22		1.97	50.01	1.50	38.10	1.39	35.31	2.26	57.40	1.31	33.27	2.22	56.39	2.36	60.02	1.00	25.40	1.38	34.93		
	60		1.97	50.01	1.06	26.90	1.39	35.31	2.61	66.29	1.31	33.27	2.57	65.28	1.55	39.40	0.50	12.70	0.75	19.05		
	61		1.97	50.01	1.38	34.93	1.39	35.31	2.61	66.29	1.31	33.27	2.57	65.28	2.11	53.67	0.88	22.23	1.25	31.75		
32	23	32	2.22	56.36	1.16	29.36	1.74	44.20	2.86	72.64	1.38	35.05	2.67	67.82	1.77	44.96	0.63	15.88	0.94	23.80		
	24		2.22	56.36	1.38	34.93	1.74	44.20	2.86	72.64	1.38	35.05	2.67	67.82	2.11	53.67	0.88	22.23	1.25	31.75		
	25		2.22	56.36	1.78	45.24	1.74	44.20	2.51	63.75	1.38	35.05	2.32	58.93	2.77	70.36	1.25	31.75	1.63	41.28		
	62		2.22	56.36	1.50	38.10	1.74	44.20	2.86	72.64	1.38	35.05	2.67	67.82	2.36	60.02	1.00	25.40	1.38	34.93		
36	26	36	2.47	62.71	1.16	29.36	1.94	49.28	2.83	71.88	1.41	35.81	2.76	70.10	1.77	44.96	0.63	15.88	0.94	23.80		
	27		2.47	62.71	1.50	38.10	1.94	49.28	2.83	71.88	1.41	35.81	2.76	70.10	2.36	60.02	1.00	25.40	1.38	34.93		
	28		2.47	62.71	1.83	46.48	1.94	49.28	2.48	62.99	1.41	35.81	2.41	61.21	3.02	76.71	1.44	36.50	1.84	46.74		
	47		2.47	62.71	1.06	26.90	1.94	49.28	2.83	71.88	1.41	35.81	2.76	70.10	1.55	39.40	0.50	12.70	0.75	19.05		
	63		2.47	62.71	1.38	34.93	1.94	49.28	2.83	71.88	1.41	35.81	2.76	70.10	2.11	53.67	0.88	22.23	1.25	31.75		
40	29	40	2.72	69.06	1.16	29.36	2.69	68.33	2.83	71.88	2.16	54.86	2.76	70.10	1.77	44.96	0.63	15.88	0.94	23.80		
	30		2.72	69.06	1.50	38.10	2.69	68.33	2.83	71.88	2.16	54.86	2.76	70.10	2.36	60.02	1.00	25.40	1.38	34.93		
	31		2.72	69.06	1.83	46.48	2.69	68.33	2.48	62.99	2.16	54.86	2.41	61.21	3.02	76.71	1.44	36.50	1.88	47.63		
	48		2.72	69.06	1.06	26.90	1.94	49.28	2.83	71.88	2.16	54.86	2.76	70.10	1.55	39.40	0.50	12.70	0.75	19.05		
	65		2.72	69.06	1.38	34.93	2.69	68.33	2.83	71.88	2.16	54.86	2.76	70.10	2.11	53.67	0.88	22.23	1.25	31.75		
44	32	44	2.97	75.41	1.16	29.36	2.69	68.33	2.83	71.88	2.16	54.86	2.76	70.10	1.77	44.96	0.63	15.88	0.94	23.80		
	33		2.97	75.41	1.50	38.10	2.69	68.33	2.83	71.88	2.16	54.86	2.76	70.10	2.36	60.02	1.00	25.40	1.38	34.93		
	34		2.97	75.41	1.83	46.48	2.69	68.33	2.48	62.99	2.16	54.86	2.41	61.21	3.02	76.71	1.44	36.50	1.88	47.63		
	67		2.97	75.41	1.38	34.93	2.69	68.33	2.83	71.88	2.16	54.86	2.76	70.10	2.11	53.67	0.88	22.23	1.25	31.75		
	68		2.97	75.41	1.78	45.24	2.69	68.33	2.83	71.88	2.16	54.86	2.76	70.10	2.77	70.36	1.25	31.75	1.63	41.28		
48	35	48	3.22	81.76	1.16	29.36	2.69	68.33	2.83	71.88	2.16	54.86	2.76	70.10	1.77	44.96	0.63	15.88	0.94	23.80		
	36		3.22	81.76	1.50	38.10	2.69	68.33	2.83	71.88	2.16	54.86	2.76	70.10	2.36	60.02	1.00	25.40	1.38	34.93		
	37		3.22	81.76	1.83	46.48	2.69	68.33	2.48	62.99	2.16	54.86	2.41	61.21	3.02	76.71	1.44	36.50	1.88	47.63		
	69		3.22	81.76	1.38	34.93	2.69	68.33	2.83	71.88	2.16	54.86	2.76	70.10	2.11	53.67	0.88	22.23	1.25	31.75		
	70		3.22	81.76	1.78	45.24	2.69	68.33	2.83	71.88	2.16	54.86	2.76	70.10	2.77	70.36	1.25	31.75	1.63	41.28		

STRAIGHT; SPIN COUPLING

26482 Series II; 5015 (MS345X); 83723 Series III

MIL Part Number

M85049	/10	-10	W
Series	Slash Sheet	Dash Number (Table A)	Finish (Table 2, pg. 14)
	10 : Straight		

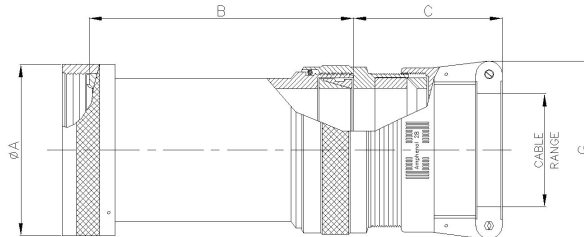

MIL PART NUMBER DESIGNATOR		CONNECTOR SHELL SIZE	A DIA. (MAX)		B (MAX)		C (REF) L MAX		G (MAX) L MAX		CABLE RANGE			
SHELL SIZE	DASH NO		INCH	MM	INCH	MM	INCH	MM	INCH	MM	MIN WIRE		MAX WIRE	
											INCH	MM	INCH	MM
08	05	8	0.62	15.67	2.13	54.10	1.54	39.22	0.96	24.31	0.13	3.18	0.25	6.35
	06		0.62	15.67	3.13	79.50	1.54	39.22	0.96	24.31	0.13	3.18	0.25	6.35
	07*		0.62	15.67	2.88	73.15	1.54	39.22	1.15	29.08	0.25	6.35	0.44	11.10
	08*		0.62	15.67	3.88	98.55	1.54	39.22	1.15	29.08	0.25	6.35	0.44	11.10
10	09	10	0.73	18.64	2.13	54.10	1.54	39.22	0.96	24.31	0.13	3.18	0.31	7.92
	10		0.73	18.64	3.13	79.50	1.54	39.22	0.96	24.31	0.13	3.18	0.31	7.92
	11*		0.73	18.64	2.88	73.15	1.54	39.22	1.15	29.08	0.25	6.35	0.44	11.10
	12*		0.73	18.64	3.88	98.55	1.54	39.22	1.15	29.08	0.25	6.35	0.44	11.10
	136		0.73	18.64	2.13	54.10	1.54	39.22	1.15	29.08	0.25	6.35	0.38	9.53
12	137	7/12	0.73	18.64	3.13	79.50	1.54	39.22	1.15	29.08	0.25	6.35	0.38	9.53
	13		0.86	21.79	2.13	54.10	1.54	39.22	1.15	29.08	0.25	6.35	0.44	11.10
	14		0.86	21.79	3.13	79.50	1.54	39.22	1.15	29.08	0.25	6.35	0.44	11.10
	15*		0.86	21.79	2.88	73.15	1.84	46.84	1.33	33.83	0.35	8.89	0.63	15.88
	16*		0.86	21.79	3.88	98.55	1.84	46.84	1.33	33.83	0.35	8.89	0.63	15.88
	111		0.86	21.79	2.13	54.10	1.84	46.84	1.33	33.83	0.35	8.89	0.50	12.70
	114		0.86	21.79	2.13	54.10	1.54	39.22	0.96	24.31	0.13	3.18	0.31	7.92
	115		0.86	21.79	3.13	79.50	1.54	39.22	0.96	24.31	0.13	3.18	0.31	7.92
14	138	12/14	0.86	21.79	2.13	54.10	1.84	46.84	1.33	33.83	0.35	8.89	0.50	12.70
	139		0.86	21.79	3.13	79.50	1.84	46.84	1.33	33.83	0.35	8.89	0.50	12.70
	17		0.98	24.99	2.13	54.10	1.84	46.84	1.33	33.83	0.35	8.89	0.58	14.61
	18		0.98	24.99	3.13	79.50	1.84	46.84	1.33	33.83	0.35	8.89	0.58	14.61
	19*		0.98	24.99	2.88	73.15	1.92	48.67	1.55	39.40	0.50	12.70	0.75	19.05
	20*		0.98	24.99	3.88	98.55	1.92	48.67	1.55	39.40	0.50	12.70	0.75	19.05
	116		0.98	24.99	2.13	54.10	1.54	39.22	1.15	29.08	0.25	6.35	0.44	11.10
	117		0.98	24.99	3.13	79.50	1.54	39.22	1.15	29.08	0.25	6.35	0.44	11.10
16	150	19/16	0.98	24.99	2.13	54.10	1.54	39.22	0.96	24.31	0.13	3.18	0.31	7.92
	151		0.98	24.99	3.13	79.50	1.54	39.22	0.96	24.31	0.13	3.18	0.31	7.92
	21		1.11	28.24	2.13	54.10	1.92	48.67	1.55	39.40	0.50	12.70	0.70	17.78
	22		1.11	28.24	3.13	79.50	1.92	48.67	1.55	39.40	0.50	12.70	0.70	17.78
	23*		1.11	28.24	2.88	73.15	2.00	50.80	1.77	44.96	0.63	15.88	0.94	23.80
	24*		1.11	28.24	3.88	98.55	2.00	50.80	1.77	44.96	0.63	15.88	0.94	23.80
	112		1.11	28.24	2.13	54.10	1.54	39.22	1.15	29.08	0.25	6.35	0.44	11.10
	113		1.11	28.24	3.13	79.50	1.54	39.22	1.15	29.08	0.25	6.35	0.44	11.10
	118		1.11	28.24	2.13	54.10	1.84	46.84	1.33	33.83	0.35	8.89	0.63	15.88
	119		1.11	28.24	3.13	79.50	1.84	46.84	1.33	33.83	0.35	8.89	0.63	15.88
152	1.11	28.24	2.13	54.10	1.54	39.22	0.96	24.31	0.13	3.18	0.31	7.92		
153	1.11	28.24	3.13	79.50	1.54	39.22	0.96	24.31	0.13	3.18	0.31	7.92		

Table continued

STRAIGHT; SPIN COUPLING

26482 Series II; 5015 (MS345X); 83723 Series III

MIL PART NUMBER DESIGNATOR		CONNECTOR SHELL SIZE	TABLE - A													
SHELL SIZE	DASH NO		A DIA. (MAX)		B (MAX)		C (REF) L MAX		G (MAX) L MAX		CABLE RANGE					
			INCH	MM	INCH	MM	INCH	MM	INCH	MM	MIN WIRE		MAX WIRE			
										INCH	MM	INCH	MM			
18	25	27/18	1.22	30.94	2.13	54.10	1.84	46.84	1.33	33.83	0.35	8.89	0.63	15.88		
	26		1.22	30.94	3.13	79.50	1.84	46.84	1.33	33.83	0.35	8.89	0.63	15.88		
	27		1.22	30.94	2.13	54.10	1.92	48.67	1.55	39.40	0.50	12.70	0.75	19.05		
	28		1.22	30.94	3.13	79.50	1.92	48.67	1.55	39.40	0.50	12.70	0.75	19.05		
	29*		1.22	30.94	2.88	73.15	2.00	50.80	1.77	44.96	0.63	15.88	0.94	23.80		
	30*		1.22	30.94	3.88	98.55	2.00	50.80	1.77	44.96	0.63	15.88	0.94	23.80		
	120		1.22	30.94	2.13	54.10	1.54	39.22	0.96	24.31	0.13	3.18	0.31	7.92		
	121		1.22	30.94	3.13	79.50	1.54	39.22	0.96	24.31	0.13	3.18	0.31	7.92		
	122		1.22	30.94	2.13	54.10	1.54	39.22	1.15	29.08	0.25	6.35	0.44	11.10		
	123		1.22	30.94	3.13	79.50	1.54	39.22	1.15	29.08	0.25	6.35	0.44	11.10		
	20		31	37/20	1.35	34.16	3.13	79.50	1.84	46.84	1.33	33.83	0.35	8.89	0.63	15.88
			32		1.35	34.16	4.13	104.90	1.84	46.84	1.33	33.83	0.35	8.89	0.63	15.88
33		1.35	34.16		3.13	79.50	1.92	48.67	1.55	39.40	0.50	12.70	0.75	19.05		
34		1.35	34.16		4.13	104.90	1.92	48.67	1.55	39.40	0.50	12.70	0.75	19.05		
35*		1.35	34.16		3.88	98.55	2.00	50.80	1.77	44.96	0.63	15.88	0.94	23.80		
36*		1.35	34.16		4.88	123.95	2.00	50.80	1.77	44.96	0.63	15.88	0.94	23.80		
37*		1.35	34.16		3.88	98.55	2.23	56.64	2.11	53.67	0.88	22.23	1.25	31.75		
38*		1.35	34.16		4.88	123.95	2.23	56.64	2.11	53.67	0.88	22.23	1.25	31.75		
124		1.35	34.16		3.13	79.50	1.54	39.22	1.15	29.08	0.25	6.35	0.44	11.10		
125		1.35	34.16		4.13	104.90	1.54	39.22	1.15	29.08	0.25	6.35	0.44	11.10		
140		1.35	34.16		3.13	79.50	2.00	50.80	1.77	44.96	0.63	15.88	0.90	22.96		
141		1.35	34.16		4.13	104.90	2.00	50.80	1.77	44.96	0.63	15.88	0.90	22.96		
22		39	22		1.47	37.29	3.13	79.50	1.84	46.84	1.33	33.83	0.35	8.89	0.63	15.88
		40			1.47	37.29	4.13	104.90	1.84	46.84	1.33	33.83	0.35	8.89	0.63	15.88
	41	1.47		37.29	3.13	79.50	1.92	48.67	1.55	39.40	0.50	12.70	0.75	19.05		
	42	1.47		37.29	4.13	104.90	1.92	48.67	1.55	39.40	0.50	12.70	0.75	19.05		
	43	1.47		37.29	3.13	79.50	2.00	50.80	1.77	44.96	0.63	15.88	0.94	23.80		
	44	1.47		37.29	4.13	104.90	2.00	50.80	1.77	44.96	0.63	15.88	0.94	23.80		
	45*	1.47		37.29	3.88	98.55	2.23	56.64	2.11	53.67	0.88	22.23	1.25	31.75		
	46*	1.47		37.29	4.88	123.95	2.23	56.64	2.11	53.67	0.88	22.23	1.25	31.75		
	126	1.47		37.29	3.13	79.50	1.54	39.22	0.96	24.31	0.13	3.18	0.31	7.92		
	127	1.47		37.29	4.13	104.90	1.54	39.22	0.96	24.31	0.13	3.18	0.31	7.92		
	128	1.47		37.29	3.13	79.50	1.54	39.22	1.15	29.08	0.25	6.35	0.44	11.10		
	129	1.47		37.29	4.13	104.90	1.54	39.22	1.15	29.08	0.25	6.35	0.44	11.10		
	142	1.47		37.29	3.13	79.50	2.23	56.64	2.11	53.67	0.88	22.23	1.03	26.14		
	143	1.47		37.29	4.13	104.90	2.23	56.64	2.11	53.67	0.88	22.23	1.03	26.14		
	24	47		24	1.59	40.46	3.13	79.50	1.92	48.67	1.55	39.40	0.50	12.70	0.75	19.05
		48			1.59	40.46	4.13	104.90	1.92	48.67	1.55	39.40	0.50	12.70	0.75	19.05
49		1.59	40.46		3.13	79.50	2.00	50.80	1.77	44.96	0.63	15.88	0.81	20.62		
50		1.59	40.46		4.13	104.90	2.00	50.80	1.77	44.96	0.63	15.88	0.81	20.62		
51		1.59	40.46		3.13	79.50	2.00	50.80	1.77	44.96	0.63	15.88	0.94	23.80		
52		1.59	40.46		4.13	104.90	2.00	50.80	1.77	44.96	0.63	15.88	0.94	23.80		
53*		1.59	40.46		3.88	98.55	2.23	56.64	2.11	53.67	0.88	22.23	1.25	31.75		
54*		1.59	40.46		4.88	123.95	2.23	56.64	2.11	53.67	0.88	22.23	1.25	31.75		
130		1.59	40.46		3.13	79.50	1.84	46.84	1.33	33.83	0.35	8.89	0.63	15.88		
131		1.59	40.46		4.13	104.90	1.84	46.84	1.33	33.83	0.35	8.89	0.63	15.88		
144		1.59	40.46		3.13	79.50	2.23	56.64	2.11	53.67	0.88	22.23	1.14	29.06		
145		1.59	40.46		4.13	104.90	2.23	56.64	2.11	53.67	0.88	22.23	1.14	29.06		
28		55	28		1.97	50.01	3.13	79.50	1.92	48.67	1.55	39.40	0.50	12.70	0.75	19.05
		56			1.97	50.01	4.13	104.90	1.92	48.67	1.55	39.40	0.50	12.70	0.75	19.05
	57	1.97		50.01	3.13	79.50	2.00	50.80	1.77	44.96	0.63	15.88	0.94	23.80		
	58	1.97		50.01	4.13	104.90	2.00	50.80	1.77	44.96	0.63	15.88	0.94	23.80		
	59	1.97		50.01	3.13	79.50	2.23	56.64	2.11	53.67	0.88	22.23	1.25	31.75		
	60	1.97		50.01	4.13	104.90	2.23	56.64	2.11	53.67	0.88	22.23	1.25	31.75		
	61	1.97		50.01	3.13	79.50	2.02	51.41	23.63	600.20	1.00	25.40	1.38	34.93		
	62	1.97		50.01	4.13	104.90	2.02	51.41	2.36	60.02	1.00	25.40	1.38	34.93		

(*Denotes Style- 2
Table continued

STRAIGHT; SPIN COUPLING

26482 Series II; 5015 (MS345X); 83723 Series III

MIL PART NUMBER DESIGNATOR		CONNECTOR SHELL SIZE	TABLE - A											
SHELL SIZE	DASH NO		A DIA. (MAX)		B (MAX)		C (REF) L MAX		G (MAX) L MAX		CABLE RANGE			
			INCH	MM	INCH	MM	INCH	MM	INCH	MM	MIN WIRE		MAX WIRE	
											INCH	MM	INCH	MM
32	63	32	2.22	56.36	3.13	79.50	2.00	50.80	1.77	44.96	0.63	15.88	0.94	23.80
	64		2.22	56.36	4.13	104.90	2.00	50.80	1.77	44.96	0.63	15.88	0.94	23.80
	65		2.22	56.36	3.13	79.50	2.23	56.64	2.11	53.67	0.88	22.23	12.50	317.50
	66		2.22	56.36	4.13	104.90	2.23	56.64	2.11	53.67	0.88	22.23	1.25	31.75
	67		2.22	56.36	3.13	79.50	2.02	51.41	2.36	60.02	1.00	25.40	1.38	34.93
	68		2.22	56.36	4.13	104.90	2.02	51.41	2.36	60.02	1.00	25.40	1.38	34.93
	69		2.22	56.36	3.13	79.50	2.55	64.77	2.77	70.36	1.25	31.75	1.63	41.28
70	2.22	56.36	4.13	104.90	2.55	64.77	2.77	70.36	1.25	31.75	1.63	41.28		
36	71	36	2.47	62.71	4.13	104.90	2.23	56.64	2.11	53.67	0.88	22.23	1.25	31.75
	72		2.47	62.71	5.13	130.30	2.23	56.64	2.11	53.67	0.88	22.23	1.25	31.75
	73		2.47	62.71	4.13	104.90	2.02	51.41	2.36	60.02	1.00	25.40	1.38	34.93
	74		2.47	62.71	5.13	130.30	2.02	51.41	2.36	60.02	1.00	25.40	1.38	34.93
	75		2.47	62.71	4.13	104.90	2.55	64.77	2.77	70.36	1.25	31.75	1.63	41.28
	76		2.47	62.71	5.13	130.30	2.55	64.77	2.77	70.36	1.25	31.75	1.63	41.28
	77*		2.47	62.71	5.01	127.25	2.60	66.04	3.02	76.71	1.44	36.50	1.88	47.63
	78*		2.47	62.71	6.01	152.65	2.60	66.04	3.02	76.71	1.44	36.50	1.88	47.63
	132		2.47	62.71	4.13	104.90	1.92	48.67	1.55	39.40	0.50	12.70	0.75	19.05
	133		2.47	62.71	5.13	130.30	1.92	48.67	1.55	39.40	0.50	12.70	0.75	19.05
	146		2.47	62.71	4.13	104.90	2.60	66.04	3.02	76.71	1.44	36.50	1.84	46.74
	147		2.47	62.71	5.13	130.30	2.60	66.04	3.02	76.71	1.44	36.50	1.84	46.74
	148		2.47	62.71	4.13	104.90	2.00	50.80	1.77	44.96	0.63	15.88	0.94	23.80
	149		2.47	62.71	5.13	130.30	2.00	50.80	1.77	44.96	0.63	15.88	0.94	23.80
40	79	40	2.72	69.06	4.13	104.90	2.23	56.64	2.11	53.67	0.88	22.23	1.25	31.75
	80		2.72	69.06	5.13	130.30	2.23	56.64	2.11	53.67	0.88	22.23	1.25	31.75
	81		2.72	69.06	4.13	104.90	2.02	51.41	2.36	60.02	1.00	25.40	1.38	34.93
	82		2.72	69.06	5.13	130.30	2.02	51.41	2.36	60.02	1.00	25.40	1.38	34.93
	83		2.72	69.06	4.13	104.90	2.55	64.77	2.77	70.36	1.25	31.75	1.63	41.28
	84		2.72	69.06	5.13	130.30	2.55	64.77	2.77	70.36	1.25	31.75	1.63	41.28
	85		2.72	69.06	4.13	104.90	2.60	66.04	3.02	76.71	1.44	36.50	1.88	47.63
	86		2.72	69.06	5.13	130.30	2.60	66.04	3.02	76.71	1.44	36.50	1.88	47.63
	134		2.72	69.06	4.13	104.90	1.92	48.67	1.55	39.40	0.50	12.70	0.75	19.05
	135		2.72	69.06	5.13	130.30	1.92	48.67	1.55	39.40	0.50	12.70	0.75	19.05
	156		2.72	69.06	4.13	104.90	2.00	50.80	1.77	44.96	0.63	15.88	0.94	23.80
157	2.72	69.06	5.13	130.30	2.00	50.80	1.77	44.96	0.63	15.88	0.94	23.80		
44	87	44	2.97	75.41	4.13	104.90	2.23	56.64	2.11	53.67	0.88	22.23	1.25	31.75
	88		2.97	75.41	5.13	130.30	2.23	56.64	2.11	53.67	0.88	22.23	1.25	31.75
	89		2.97	75.41	4.13	104.90	2.02	51.41	2.36	60.02	1.00	25.40	1.38	34.93
	90		2.97	75.41	5.13	130.30	2.02	51.41	2.36	60.02	1.00	25.40	1.38	34.93
	91		2.97	75.41	4.13	104.90	2.55	64.77	2.77	70.36	1.25	31.75	1.63	41.28
	92		2.97	75.41	5.13	130.30	2.55	64.77	2.77	70.36	1.25	31.75	1.63	41.28
	93		2.97	75.41	4.13	104.90	2.60	66.04	3.02	76.71	1.44	36.50	1.88	47.63
	94		2.97	75.41	5.13	130.30	2.60	66.04	3.02	76.71	1.44	36.50	1.88	47.63
	154		2.97	75.41	4.13	104.90	2.00	50.80	1.77	44.96	0.63	15.88	0.94	23.80
155	2.97	75.41	5.13	130.30	2.00	50.80	1.77	44.96	0.63	15.88	0.94	23.80		
48	95	48	3.22	81.76	4.13	104.90	2.23	56.64	2.11	53.67	0.88	22.23	1.25	31.75
	96		3.22	81.76	5.13	130.30	2.23	56.64	2.11	53.67	0.88	22.23	1.25	31.75
	97		3.22	81.76	4.13	104.90	2.02	51.41	2.36	60.02	1.00	25.40	1.38	34.93
	98		3.22	81.76	5.13	130.30	2.02	51.41	2.36	60.02	1.00	25.40	1.38	34.93
	99		3.22	81.76	4.13	104.90	2.55	64.77	2.77	70.36	1.25	31.75	1.63	41.28
	100		3.22	81.76	5.13	130.30	2.55	64.77	2.77	70.36	1.25	31.75	1.63	41.28
	101		3.22	81.76	4.13	104.90	2.60	66.04	3.02	76.71	1.44	36.50	1.88	47.63
102	3.22	81.76	5.13	130.30	2.60	66.04	3.02	76.71	1.44	36.50	1.88	47.63		

90° & 45°; SPIN COUPLING

26482 Series II; 5015 (MS345X); 83723 Series III

MIL Part Number

M85049	/8	-10	W
Series	Slash Sheet	Dash Number (Table A)	Finish (Table 2, pg. 14)
	6: 45° 8: 90°		

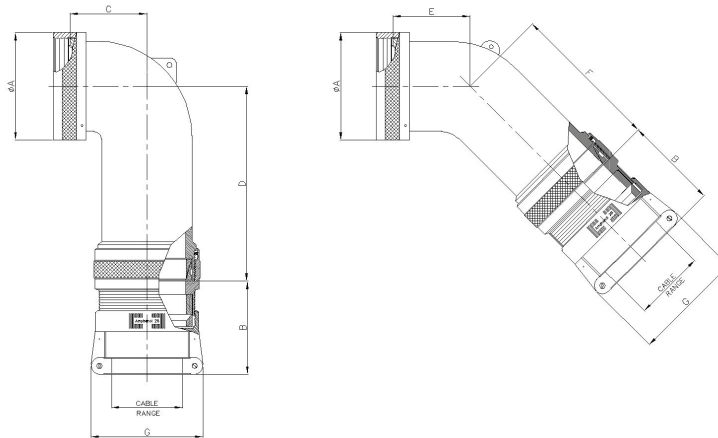

TABLE - A

MIL PART NUMBER DESIGNATOR		CONNECTOR SHELL SIZE	A DIA. (MAX)		B (REF)		C (MAX)		D (MAX)		E (MAX)		F (MAX)		G (MAX)		CABLE RANGE			
SHELL SIZE	DASH NO		INCH	MM	INCH	MM	INCH	MM	INCH	MM	INCH	MM	INCH	MM	INCH	MM	MIN WIRE		MAX WIRE	
																	INCH	MM	INCH	MM
08	3	8	0.62	15.67	1.54	39.22	0.67	17.02	1.26	32.00	0.63	16.00	1.25	31.75	0.96	24.31	0.13	3.18	0.25	6.35
10	4	10	0.73	18.64	1.54	39.22	0.76	19.30	1.98	50.29	0.69	17.53	1.92	48.77	0.96	24.31	0.13	3.18	0.31	7.92
	49*		0.73	18.64	1.54	39.22	1.52	38.61	2.00	50.80	1.50	38.10	1.98	50.29	1.15	29.08	0.25	6.35	0.44	11.10
	5		0.73	18.64	1.54	39.22	0.76	19.30	1.38	35.05	0.69	17.53	1.31	33.27	1.15	29.08	0.25	6.35	0.38	9.53
12	6	7/12	0.86	21.79	1.54	39.22	0.77	19.56	2.00	50.80	0.75	19.05	1.98	50.29	0.96	24.31	0.13	3.18	0.31	7.92
	71*		0.86	21.79	1.84	46.84	1.81	45.97	2.16	54.86	1.65	41.91	2.18	55.37	1.33	33.83	0.35	8.89	0.63	15.88
	7		0.86	21.79	1.54	39.22	0.77	19.56	2.00	50.80	0.75	19.05	1.98	50.29	1.15	29.08	0.25	6.35	0.44	11.10
	8		0.86	21.79	1.84	46.84	0.77	19.56	1.40	35.56	0.75	19.05	1.98	50.29	1.33	33.83	0.35	8.89	0.50	12.70
14	9	12/14	0.98	24.99	1.54	39.22	0.87	22.10	2.07	52.58	0.81	20.57	2.07	52.58	1.15	29.08	0.25	6.35	0.44	11.10
	10		0.98	24.99	1.84	46.84	0.87	22.10	1.72	43.69	0.81	20.57	1.72	43.69	1.33	33.83	0.35	8.89	0.58	14.61
	50*		0.98	24.99	1.92	48.67	1.89	48.01	2.33	59.18	1.84	46.74	2.37	60.20	1.55	39.40	0.50	12.70	0.75	19.05
	74		0.98	24.99	1.54	39.22	0.87	22.10	2.07	52.58	0.81	20.57	2.07	52.58	0.96	24.31	0.13	3.18	0.31	7.92
16	11	19/16	1.11	28.24	1.54	39.22	1.05	26.67	2.16	54.86	0.91	23.11	2.18	55.37	1.15	29.08	0.25	6.35	0.44	11.10
	12		1.11	28.24	1.92	48.67	1.05	26.67	1.81	45.97	0.91	23.11	1.82	46.23	1.55	39.40	0.50	12.70	0.70	17.78
	40		1.11	28.24	1.84	46.84	1.05	26.67	2.16	54.86	0.91	23.11	2.18	55.37	1.33	33.83	0.35	8.89	0.63	15.88
	51*		1.11	28.24	2.00	50.80	2.04	51.82	2.44	61.98	1.94	49.28	2.52	64.01	1.77	44.96	0.63	15.88	0.94	23.80
	75		1.11	28.24	1.54	39.22	1.05	26.67	2.16	54.86	0.91	23.11	2.18	55.37	0.96	24.31	0.13	3.18	0.31	7.92

Table continued

90° & 45°; SPIN COUPLING

26482 Series II; 5015 (MS345X); 83723 Series III

MIL PART NUMBER DESIGNATOR		CONNECTOR SHELL SIZE	TABLE - A																CABLE RANGE			
			A DIA. (MAX)		B (REF)		C (MAX)		D (MAX)		E (MAX)		F (MAX)		G (MAX)		MIN WIRE		MAX WIRE			
			INCH	MM	INCH	MM	INCH	MM	INCH	MM	INCH	MM	INCH	MM	INCH	MM	INCH	MM	INCH	MM		
18	13	27/18	1.22	30.94	1.84	46.84	1.14	28.96	2.33	59.18	1.09	27.69	2.37	60.20	1.33	33.83	0.35	8.89	0.63	15.88		
	14		1.22	30.94	2.00	50.80	1.14	28.96	1.98	50.29	1.09	27.69	2.00	50.80	1.77	44.96	0.63	15.88	0.78	19.79		
	41		1.22	30.94	1.54	39.22	1.14	28.96	2.33	59.18	1.09	27.69	2.37	60.20	0.96	24.31	0.13	3.18	0.31	7.92		
	42		1.22	30.94	1.54	39.22	1.14	28.96	2.33	59.18	1.09	27.69	2.37	60.20	1.15	29.08	0.25	6.35	0.44	11.10		
	52		1.22	30.94	1.92	48.67	1.14	28.96	2.33	59.18	1.09	27.69	2.37	60.20	1.55	39.40	0.50	12.70	0.75	19.05		
	72*		1.22	30.94	2.00	50.80	2.05	52.07	2.44	61.98	1.94	49.28	2.52	64.01	1.77	44.96	0.63	15.88	0.94	23.80		
20	15	37/20	1.35	34.16	1.84	46.84	1.14	28.96	2.33	59.18	1.09	27.69	2.37	60.20	1.33	33.83	0.35	8.89	0.63	15.88		
	16		1.35	34.16	2.00	50.80	1.14	28.96	1.98	50.29	1.09	27.69	2.00	50.80	1.77	44.96	0.63	15.88	0.90	22.96		
	43		1.35	34.16	1.54	39.22	1.14	28.96	2.33	59.18	1.09	27.69	2.37	60.20	1.15	29.08	0.25	6.35	0.44	11.10		
	54		1.35	34.16	1.92	48.67	1.14	28.96	2.33	59.18	1.09	27.69	2.37	60.20	1.55	39.40	0.50	12.70	0.75	19.05		
	55		1.35	34.16	2.23	56.64	2.14	54.36	2.61	66.29	2.06	52.32	2.57	65.28	2.11	53.67	0.88	22.23	1.25	31.75		
22	17	22	1.47	37.29	1.92	48.72	1.29	32.77	2.44	61.98	1.19	30.23	2.52	64.01	1.55	39.40	0.50	12.70	0.75	19.05		
	18		1.47	37.29	2.23	56.64	1.29	32.77	2.09	53.09	1.19	30.23	2.16	54.86	2.11	53.67	0.88	22.23	1.03	26.14		
	44		1.47	37.29	1.54	39.22	1.29	32.77	2.44	61.98	1.19	30.23	2.52	64.01	0.96	24.31	0.13	3.18	0.31	7.92		
	45		1.47	37.29	1.54	39.22	1.29	32.77	2.44	61.98	1.19	30.23	2.52	64.01	1.15	29.08	0.25	6.35	0.44	11.10		
	56		1.47	37.29	1.84	46.84	1.29	32.77	2.44	61.98	1.19	30.23	2.52	64.01	1.33	33.83	0.35	8.89	0.63	15.88		
	57		1.47	37.29	2.00	50.80	1.29	32.77	2.44	61.98	1.19	30.23	2.52	64.01	1.77	44.96	0.63	15.88	0.94	23.80		
	58*		1.47	37.29	2.23	56.64	2.14	54.36	2.61	66.29	2.06	52.32	2.57	65.28	2.11	53.67	0.88	22.23	1.25	31.75		
24	19	24	1.59	40.46	1.92	48.67	1.29	32.77	2.44	61.98	1.19	30.23	2.52	64.01	1.55	39.40	0.50	12.70	0.75	19.05		
	20		1.59	40.46	2.23	56.64	1.29	32.77	2.09	53.09	1.19	30.23	2.16	54.86	2.11	53.67	0.88	22.23	1.14	29.06		
	46		1.59	40.46	1.84	46.84	1.29	32.77	2.44	61.98	1.19	30.23	2.52	64.01	1.33	33.83	0.35	8.89	0.63	15.88		
	59		1.59	40.46	2.00	50.80	1.29	32.77	2.44	61.98	1.19	30.23	2.52	64.01	1.77	44.96	0.63	15.88	0.94	23.80		
	73*		1.59	40.46	2.23	56.64	2.15	54.61	2.61	66.29	2.06	52.32	2.57	65.28	2.12	53.75	0.88	22.23	1.25	31.75		
28	21	28	1.97	50.01	2.00	50.80	1.39	35.31	2.61	66.29	1.31	33.27	2.57	65.28	1.77	44.96	0.63	15.88	0.94	23.80		
	22		1.97	50.01	2.02	51.41	1.39	35.31	2.26	57.40	1.31	33.27	2.22	56.39	2.36	60.02	1.00	25.40	1.38	34.93		
	60		1.97	50.01	1.92	48.67	1.39	35.31	2.61	66.29	1.31	33.27	2.57	65.28	1.55	39.40	0.50	12.70	0.75	19.05		
	61		1.97	50.01	2.23	56.64	1.39	35.31	2.61	66.29	1.31	33.27	2.57	65.28	2.11	53.67	0.88	22.23	1.25	31.75		
32	23	32	2.22	56.36	2.00	50.80	1.74	44.20	2.86	72.64	1.38	35.05	2.67	67.82	1.77	44.96	0.63	15.88	0.94	23.80		
	24		2.22	56.36	2.23	56.64	1.74	44.20	2.86	72.64	1.38	35.05	2.67	67.82	2.11	53.67	0.88	22.23	1.25	31.75		
	25		2.22	56.36	2.55	64.77	1.74	44.20	2.51	63.75	1.38	35.05	2.32	58.93	2.77	70.36	1.25	31.75	1.63	41.28		
	62		2.22	56.36	2.02	51.41	1.74	44.20	2.86	72.64	1.38	35.05	2.67	67.82	2.36	60.02	1.00	25.40	1.38	34.93		
36	26	36	2.47	62.71	2.00	50.80	1.94	49.28	2.83	71.88	1.41	35.81	2.76	70.10	1.77	44.96	0.63	15.88	0.94	23.80		
	27		2.47	62.71	2.02	51.41	1.94	49.28	2.83	71.88	1.41	35.81	2.76	70.10	2.36	60.02	1.00	25.40	1.38	34.93		
	28		2.47	62.71	2.60	66.04	1.94	49.28	2.48	62.99	1.41	35.81	2.41	61.21	3.02	76.71	1.44	36.50	1.84	46.74		
	47		2.47	62.71	1.92	48.67	1.94	49.28	2.83	71.88	1.41	35.81	2.76	70.10	1.55	39.40	0.50	12.70	0.75	19.05		
	63		2.47	62.71	2.23	56.64	1.94	49.28	2.83	71.88	1.41	35.81	2.76	70.10	2.11	53.67	0.88	22.23	1.25	31.75		
	64		2.47	62.71	2.55	64.77	1.94	49.28	2.83	71.88	1.41	35.81	2.76	70.10	2.77	70.36	1.25	31.75	1.63	41.28		
40	29	40	2.72	69.06	2.00	50.80	2.69	68.33	2.83	71.88	2.16	54.86	2.76	70.10	1.77	44.96	0.63	15.88	0.94	23.80		
	30		2.72	69.06	2.02	51.41	2.69	68.33	2.83	71.88	2.16	54.86	2.76	70.10	2.36	60.02	1.00	25.40	1.38	34.93		
	31		2.72	69.06	2.60	66.04	2.69	68.33	2.48	62.99	2.16	54.86	2.41	61.21	3.02	76.71	1.44	36.50	1.88	47.63		
	48		2.72	69.06	1.92	48.67	1.94	49.28	2.83	71.88	2.16	54.86	2.76	70.10	1.55	39.40	0.50	12.70	0.75	19.05		
	65		2.72	69.06	2.23	56.64	2.69	68.33	2.83	71.88	2.16	54.86	2.76	70.10	2.11	53.67	0.88	22.23	1.25	31.75		
	66		2.72	69.06	2.55	64.77	2.69	68.33	2.83	71.88	2.16	54.86	2.76	70.10	2.77	70.36	1.25	31.75	1.63	41.28		
44	32	44	2.97	75.41	2.00	50.80	2.69	68.33	2.83	71.88	2.16	54.86	2.76	70.10	1.77	44.96	0.63	15.88	0.94	23.80		
	33		2.97	75.41	2.02	51.41	2.69	68.33	2.83	71.88	2.16	54.86	2.76	70.10	2.36	60.02	1.00	25.40	1.38	34.93		
	34		2.97	75.41	2.60	66.04	2.69	68.33	2.48	62.99	2.16	54.86	2.41	61.21	3.02	76.71	1.44	36.50	1.88	47.63		
	67		2.97	75.41	2.23	56.64	2.69	68.33	2.83	71.88	2.16	54.86	2.76	70.10	2.11	53.67	0.88	22.23	1.25	31.75		
	68		2.97	75.41	2.55	64.77	2.69	68.33	2.83	71.88	2.16	54.86	2.76	70.10	2.77	70.36	1.25	31.75	1.63	41.28		
48	35	48	3.22	81.76	2.00	50.80	2.69	68.33	2.83	71.88	2.16	54.86	2.76	70.10	1.77	44.96	0.63	15.88	0.94	23.80		
	36		3.22	81.76	2.02	51.41	2.69	68.33	2.83	71.88	2.16	54.86	2.76	70.10	2.36	60.02	1.00	25.40	1.38	34.93		
	37		3.22	81.76	2.60	66.04	2.69	68.33	2.48	62.99	2.16	54.86	2.41	61.21	3.02	76.71	1.44	36.50	1.88	47.63		
	69		3.22	81.76	2.23	56.64	2.69	68.33	2.83	71.88	2.16	54.86	2.76	70.10	2.11	53.67	0.88	22.23	1.25	31.75		
	70		3.22	81.76	2.55	64.77	2.69	68.33	2.83	71.88	2.16	54.86	2.76	70.10	2.77	70.36	1.25	31.75	1.63	41.28		

STRAIGHT; DIRECT COUPLING

38999 Series I, II

MIL Part Number

M85049	/17	10	W	03	A
Series	Slash Sheet	Shell Size (Table A)	Finish (Table 2, pg. 14)	Clamp Size (Table A)	Length (Table A) Omit for "STD"
	17: Straight				

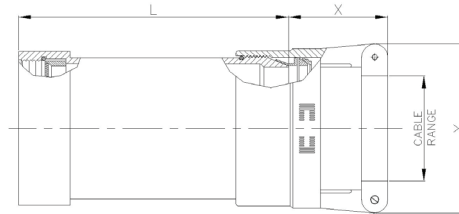

TABLE - A

MIL PART NUMBER DESIGNATOR		LENGTH	CONNECTOR SHELL SIZE SE - II / I	CABLE RANGE				L (MAX)		X (MAX)		Y (MAX)	
ACCESSORY SHELL SIZE	CLAMP SIZE			MIN		MAX		INCH	MM	INCH	MM	INCH	MM
				INCH	MM	INCH	MM						
08	01	STD.	8 / 9	0.06	1.57	0.13	3.18	1.53	38.86	1.25	31.75	0.78	19.81
		A						2.53	64.26				
	02	STD.		0.13	3.18	0.25	6.35	1.53	38.86	1.25	31.75	0.97	24.64
		A						2.53	64.26				
10	01	STD.	10 / 11	0.06	1.57	0.13	3.18	1.53	38.86	1.25	31.75	0.78	19.81
		A						2.53	64.26				
	02	STD.		0.13	3.18	0.25	6.35	1.53	38.86	1.25	31.75	0.97	24.64
		A						2.53	64.26				
	03	STD.		0.25	6.35	0.38	9.53	1.53	38.86	1.25	31.75	1.06	26.92
		A						2.53	64.26				
12	02	STD.	12 / 13	0.13	3.18	0.25	6.35	1.53	38.86	1.25	31.75	0.97	24.64
		A						2.53	64.26				
	03	STD.		0.25	6.35	0.38	9.53	1.53	38.86	1.25	31.75	1.06	26.92
		A						2.53	64.26				
	04	STD.		0.38	9.53	0.50	12.70	1.53	38.86	1.25	31.75	1.16	29.46
		A						2.53	64.26				
14	02	STD.	14 / 15	0.13	3.18	0.25	6.35	1.53	38.86	1.25	31.75	0.97	24.64
		A						2.53	64.26				
		B						3.53	89.66				
	03	STD.		0.25	6.35	0.38	9.53	1.53	38.86	1.25	31.75	1.06	26.92
		A						2.53	64.26				
		B						3.53	89.66				
	04	STD.		0.38	9.53	0.50	12.70	1.53	38.86	1.25	31.75	1.16	29.46
		A						2.53	64.26				
		B						3.53	89.66				
	05	STD.		0.50	12.70	0.63	15.88	1.53	38.86	1.31	33.27	1.25	31.75
		A						2.53	64.26				
		B						3.53	89.66				
16	02	STD.	16 / 17	0.13	3.18	0.25	6.35	1.53	38.86	1.25	31.75	0.97	24.64
		A						2.53	64.26				
		B						3.53	89.66				
	03	STD.		0.25	6.35	0.38	9.53	1.53	38.86	1.25	31.75	1.06	26.92
		A						2.53	64.26				
		B						3.53	89.66				
	04	STD.		0.38	9.53	0.50	12.70	1.53	38.86	1.25	31.75	1.16	29.46
		A						2.53	64.26				
		B						3.53	89.66				
	05	STD.		0.50	12.70	0.63	15.88	1.53	38.86	1.31	33.27	1.25	31.75
		A						2.53	64.26				
		B						3.53	89.66				
06	STD.	0.63	15.88	0.75	19.05	1.53	38.86	1.38	35.05	1.38	35.05		
	A					2.53	64.26						
	B					3.53	89.66						

Table continued

STRAIGHT; DIRECT COUPLING

38999 Series I, II

MIL PART NUMBER DESIGNATOR		CONNECTOR SHELL SIZE SE - II / I	LENGTH	CABLE RANGE				L (MAX)		X (MAX)		Y (MAX)	
ACCESSORY SHELL SIZE	CLAMP SIZE			MIN		MAX		INCH	MM	INCH	MM	INCH	MM
				INCH	MM	INCH	MM						
18	03	18 / 19	STD.	0.25	6.35	0.38	9.53	1.53	38.86	1.25	31.75	1.06	26.92
			A					2.53	64.26				
			B					3.53	89.66				
	04		STD.	0.38	9.53	0.50	12.70	1.53	38.86	1.25	31.75	1.16	29.46
			A					2.53	64.26				
			B					3.53	89.66				
	05		STD.	0.50	12.70	0.63	15.88	1.53	38.86	1.31	33.27	1.25	31.75
			A					2.53	64.26				
			B					3.53	89.66				
	06		STD.	0.63	15.88	0.75	19.05	1.53	38.86	1.38	35.05	1.38	35.05
			A					2.53	64.26				
			B					3.53	89.66				
07	STD.	0.75	19.05	0.88	22.23	1.53	38.86	1.50	38.10	1.50	38.10		
	A					2.53	64.26						
	B					3.53	89.66						
20	03	20 / 21	STD.	0.25	6.35	0.38	9.53	1.53	38.86	1.25	31.75	1.06	26.92
			A					2.53	64.26				
			B					3.53	89.66				
			C					4.53	115.06				
	04		STD.	0.38	9.53	0.50	12.70	1.53	38.86	1.25	31.75	1.16	29.46
			A					2.53	64.26				
			B					3.53	89.66				
			C					4.53	115.06				
	05		STD.	0.50	12.70	0.63	15.88	1.53	38.86	1.31	33.27	1.25	31.75
			A					2.53	64.26				
			B					3.53	89.66				
			C					4.53	115.06				
	06		STD.	0.63	15.88	0.75	19.05	1.53	38.86	1.38	35.05	1.38	35.05
			A					2.53	64.26				
			B					3.53	89.66				
			C					4.53	115.06				
	07		STD.	0.75	19.05	0.88	22.23	1.53	38.86	1.50	38.10	1.50	38.10
			A					2.53	64.26				
B		3.53	89.66										
C		4.53	115.06										
08	STD.	0.88	22.23	1.00	25.40	1.53	38.86	1.63	41.40	1.63	41.40		
	A					2.53	64.26						
	B					3.53	89.66						
	C					4.53	115.06						
22	03	22 / 23	STD.	0.25	6.35	0.38	9.53	1.53	38.86	1.25	31.75	1.06	26.92
			A					2.53	64.26				
			B					3.53	89.66				
			C					4.53	115.06				
	04		STD.	0.38	9.53	0.50	12.70	1.53	38.86	1.25	31.75	1.16	29.46
			A					2.53	64.26				
			B					3.53	89.66				
			C					4.53	115.06				
	05		STD.	0.50	12.70	0.63	15.88	1.53	38.86	1.31	33.27	1.25	31.75
			A					2.53	64.26				
			B					3.53	89.66				
			C					4.53	115.06				
06	STD.	0.63	15.88	0.75	19.05	1.53	38.86	1.38	35.05	1.38	35.05		
	A					2.53	64.26						
	B					3.53	89.66						
	C					4.53	115.06						

Table continued

STRAIGHT; DIRECT COUPLING

38999 Series I, II

MIL PART NUMBER DESIGNATOR		CONNECTOR SHELL SIZE SE - II / I	LENGTH	TABLE - A, cont.				L (MAX)		X (MAX)		Y (MAX)	
ACCESSORY SHELL SIZE	CLAMP SIZE			CABLE RANGE				INCH	MM	INCH	MM	INCH	MM
				MIN	MAX	MIN	MAX						
			INCH	MM	INCH	MM							
22, cont.	07	22 / 23	STD.	0.75	19.05	0.88	22.23	1.53	38.86	1.50	38.10	1.50	38.10
			A					2.53	64.26				
			B					3.53	89.66				
			C					4.53	115.06				
	08		STD.	0.88	22.23	1.00	25.40	1.53	38.86	1.63	41.40	1.63	41.40
			A					2.53	64.26				
			B					3.53	89.66				
			C					4.53	115.06				
	09		STD.	1.00	25.40	1.13	28.58	1.53	38.86	1.63	41.40	1.75	44.45
			A					2.53	64.26				
			B					3.53	89.66				
			C					4.53	115.06				
24	04	24 / 25	STD.	0.38	9.53	0.50	12.70	1.53	38.86	1.25	31.75	1.16	29.46
			A					2.53	64.26				
			B					3.53	89.66				
			C					4.53	115.06				
	05		STD.	0.50	12.70	0.63	15.88	1.53	38.86	1.31	33.27	1.25	31.75
			A					2.53	64.26				
			B					3.53	89.66				
			C					4.53	115.06				
	06		STD.	0.63	15.88	0.75	19.05	1.53	38.86	1.38	35.05	1.38	35.05
			A					2.53	64.26				
			B					3.53	89.66				
			C					4.53	115.06				
	07		STD.	0.75	19.05	0.88	22.23	1.53	38.86	1.50	38.10	1.50	38.10
			A					2.53	64.26				
			B					3.53	89.66				
			C					4.53	115.06				
	08		STD.	0.88	22.23	1.00	25.40	1.53	38.86	1.63	41.40	1.63	41.40
			A					2.53	64.26				
			B					3.53	89.66				
			C					4.53	115.06				
	09		STD.	1.00	25.40	1.13	28.58	1.53	38.86	1.63	41.40	1.75	44.45
			A					2.53	64.26				
			B					3.53	89.66				
			C					4.53	115.06				
10	STD.	1.13	28.58	1.25	31.75	1.53	38.86	1.63	41.40	1.88	47.75		
	A					2.53	64.26						
	B					3.53	89.66						
	C					4.53	115.06						

90° & 45°; SPIN COUPLING 38999 Series I, II

MIL Part Number

M85049	/76	10	W	03
Series	Slash Sheet	Shell Size (Table B)	Finish (Table 2, pg. 14)	Clamp Size (Table B)
	76: 90° 77: 45°			

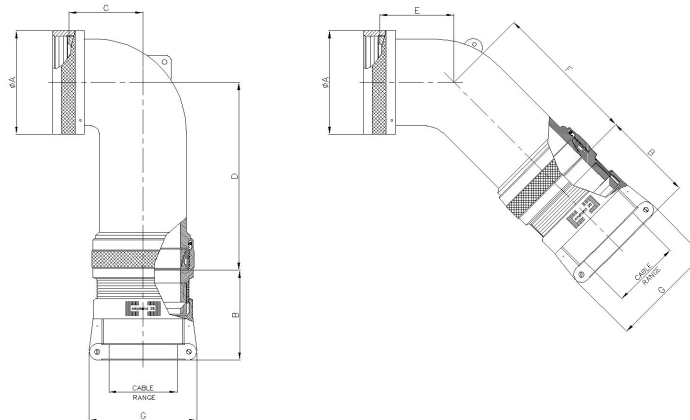

MIL PART NUMBER DESIGNATOR		CONNECTOR SHELL SIZE SE - II / I	CABLE RANGE				A DIA. (MAX)		B (MAX)		C (MAX)		D (MAX)		E (MAX)		Y (MAX)	
ACCESSORY SHELL SIZE	CLAMP SIZE		MIN		MAX		INCH	MM	INCH	MM	INCH	MM	INCH	MM	INCH	MM	INCH	MM
			INCH	MM	INCH	MM												
08	01	8 / 9	0.06	1.57	0.13	3.18	0.75	19.05	0.46	11.68	3.15	80.01	0.69	17.53	3.46	87.88	0.80	20.32
	02		0.13	3.18	0.25	6.35											1.00	25.40
10	01	10 / 11	0.06	1.57	0.13	3.18	0.85	21.59	0.52	13.21	3.21	81.53	0.78	19.81	3.58	90.93	0.80	20.32
	02		0.13	3.18	0.25	6.35											1.00	25.40
	03		0.25	6.35	0.38	9.53											1.10	27.94
12	02	12 / 13	0.13	3.18	0.25	6.35	1.00	25.40	0.58	14.73	3.27	83.06	0.80	20.32	3.60	91.44	1.00	25.40
	03		0.25	6.35	0.38	9.53											1.10	27.94
	04		0.38	9.53	0.50	12.70											1.20	30.48
14	02	14 / 15	0.13	3.18	0.25	6.35	1.15	29.21	0.65	16.51	3.36	85.34	0.88	22.35	3.67	93.22	1.00	25.40
	03		0.25	6.35	0.38	9.53											1.10	27.94
	04		0.38	9.53	0.50	12.70											1.20	30.48
	05		0.50	12.70	0.63	15.88											1.25	31.75
	06		0.63	15.88	0.75	19.05											1.40	35.56
16	02	16 / 17	0.13	3.18	0.25	6.35	1.25	31.75	0.74	18.80	3.47	88.14	0.93	23.62	3.76	95.50	1.00	25.40
	03		0.25	6.35	0.38	9.53											1.10	27.94
	04		0.38	9.53	0.50	12.70											1.20	30.48
	05		0.50	12.70	0.63	15.88											1.25	31.75
	06		0.63	15.88	0.75	19.05											1.40	35.56
18	03	18 / 19	0.25	6.35	0.38	9.53	1.40	35.56	0.93	23.62	3.66	92.96	1.01	25.65	3.93	99.82	1.10	27.94
	04		0.38	9.53	0.50	12.70											1.20	30.48
	05		0.50	12.70	0.63	15.88											1.25	31.75
	06		0.63	15.88	0.75	19.05											1.40	35.56
	07		0.75	19.05	0.88	22.23											1.50	38.10

Table continued

90° & 45°; SPIN COUPLING 38999 Series I, II

MIL PART NUMBER DESIGNATOR		CONNECTOR SHELL SIZE SE-II/I	CABLE RANGE		A DIA. (MAX)		B (MAX)		C (MAX)		D (MAX)		E (MAX)		Y (MAX)			
ACCESSORY SHELL SIZE	CLAMP SIZE		MIN		MAX		INCH	MM	INCH	MM	INCH	MM	INCH	MM	INCH	MM		
			INCH	MM	INCH	MM												
20	03	20 / 21	0.25	6.35	0.38	9.53	1.55	39.37	0.93	23.62	3.66	92.96	1.06	26.92	3.93	99.82	1.10	27.94
	04		0.38	9.53	0.50	12.70											1.20	30.48
	05		0.50	12.70	0.63	15.88											1.25	31.75
	06		0.63	15.88	0.75	19.05											1.40	35.56
	07		0.75	19.05	0.88	22.23											1.50	38.10
	08		0.88	22.23	1.00	25.40											1.65	41.91
22	03	22 / 23	0.25	6.35	0.38	9.53	1.65	41.91	1.02	25.91	3.81	96.77	1.17	29.72	4.04	102.62	1.10	27.94
	04		0.38	9.53	0.50	12.70											1.20	30.48
	05		0.50	12.70	0.63	15.88											1.25	31.75
	06		0.63	15.88	0.75	19.05											1.40	35.56
	07		0.75	19.05	0.88	22.23											1.50	38.10
	08		0.88	22.23	1.00	25.40											1.65	41.91
	09		1.00	25.40	1.13	28.58											1.75	44.45
	04		0.38	9.53	0.50	12.70											1.20	30.48
24	05	24 / 25	0.50	12.70	0.63	15.88	1.85	46.99	1.02	25.91	3.81	96.77	1.18	29.97	4.04	102.62	1.25	31.75
	06		0.63	15.88	0.75	19.05											1.40	35.56
	07		0.75	19.05	0.88	22.23											1.50	38.10
	08		0.88	22.23	1.00	25.40											1.65	41.91
	09		1.00	25.40	1.13	28.58											1.75	44.45
	10		1.13	28.58	1.25	31.75											1.90	48.26

STRAIGHT; SPIN COUPLING 38999 Series III, IV

MIL Part Number

M85049	/18	11	W	03	A
Series	Slash Sheet	Shell Size (Table A)	Finish (Table 2, pg. 14)	Clamp Size (Table A)	Length (Table A) Omit for "STD"
	18: Straight				

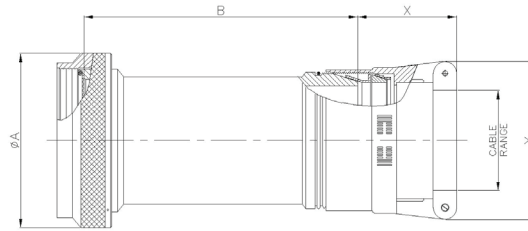

MIL PART NUMBER DESIGNATOR			CONNECTOR SHELL SIZE/CODE (REF.)	CABLE RANGE				A DIA. (MAX)		B (MAX)		X (MAX)		Y (MAX)				
CONNECTOR SHELL SIZE	CLAMP SIZE	LENGTH CODE		MIN		MAX		INCH	MM	INCH	MM	INCH	MM	INCH	MM			
				INCH	MM	INCH	MM											
9	01	STD.	09 / A	0.06	1.57	0.13	3.18	0.75	19.05	1.53	38.86	1.25	31.75	0.80	20.32			
		A								2.53	64.26							
	02	STD.		0.13	3.18	0.25	6.35			1.53	38.86							
	A	2.53		64.26														
11	01	STD.		11 / B	0.06	1.57	0.13			3.18	0.85	21.59	1.53	38.86	1.25	31.75	0.80	20.32
		A											2.53	64.26				
	02	STD.			0.13	3.18	0.25			6.35			1.53	38.86				
	A	2.53			64.26													
	03	STD.	0.25		6.35	0.38	9.53	1.53	38.86	1.25			31.75	1.10	27.94			
		A	2.53		64.26													
02		STD.	0.13		3.18	0.25	6.35	1.53	38.86	1.25			31.75	1.00	25.40			
A		2.53	64.26															
13	02	STD.	13 / C		0.13	3.18	0.25	6.35	1.00	25.40			1.53	38.86	1.25	31.75	1.00	25.40
		A											2.53	64.26				
	03	STD.			0.25	6.35	0.38	9.53					1.53	38.86				
	A	2.53			64.26													
15	02	STD.		15 / D	0.13	3.18	0.25	6.35			1.15	29.21	1.53	38.86	1.25	31.75	1.00	25.40
		A											2.53	64.26				
		B											3.53	89.66				
		03											STD.	0.25				
	A	2.53	64.26															
	B	3.53	89.66															
	04	STD.	0.38		9.53	0.50	12.70	1.53	38.86	1.25			31.75	1.20	30.48			
		A	2.53		64.26													
		B	3.53		89.66													
		05	STD.		0.50	12.70	0.63	15.88	1.53	38.86			1.31	33.27	1.25	31.75		
	A	2.53	64.26															
	B	3.53	89.66															
17	02	STD.	17 / E	0.13	3.18	0.25	6.35	1.25	31.75	1.53	38.86	1.25	31.75	1.00	25.40			
		A								2.53	64.26							
		B								3.53	89.66							
		03								STD.	0.25					6.35	0.38	9.53
	A	2.53		64.26														
	B	3.53		89.66														
	04	STD.		0.38	9.53	0.50	12.70			1.53	38.86	1.25	31.75	1.20	30.48			
		A		2.53	64.26													
		B		3.53	89.66													
		05		STD.	0.50	12.70	0.63			15.88	1.53	38.86	1.31	33.27	1.25	31.75		
	A	2.53		64.26														
	B	3.53		89.66														
06	STD.	0.63	15.88	0.75	19.05	1.53	38.86	1.38	35.05	1.40	35.56							
	A	2.53	64.26															
	B	3.53	89.66															

Table continued

STRAIGHT; SPIN COUPLING 38999 Series III, IV

MIL PART NUMBER DESIGNATOR			CONNECTOR SHELL SIZE/CODE (REF.)	CABLE RANGE				A DIA. (MAX)		B (MAX)		X (MAX)		Y (MAX)	
CONNECTOR SHELL SIZE	CLAMP SIZE	LENGTH CODE		MIN		MAX		INCH	MM	INCH	MM	INCH	MM	INCH	MM
				INCH	MM	INCH	MM								
19	03	STD.	19 / F	0.25	6.35	0.38	9.53	1.40	35.56	1.53	38.86	1.25	31.75	1.10	27.94
		A								2.53	64.26				
		B								3.53	89.66				
	04	STD.		0.38	9.53	0.50	12.70			1.53	38.86	1.25	31.75	1.20	30.48
		A								2.53	64.26				
		B								3.53	89.66				
	05	STD.		0.50	12.70	0.63	15.88			1.53	38.86	1.31	33.27	1.25	31.75
		A								2.53	64.26				
		B								3.53	89.66				
	06	STD.		0.63	15.88	0.75	19.05			1.53	38.86	1.38	35.05	1.40	35.56
		A								2.53	64.26				
		B								3.53	89.66				
07	STD.	0.75	19.05	0.88	22.23	1.53	38.86	1.50	38.10	1.50	38.10				
	A					2.53	64.26								
	B					3.53	89.66								
21	03	STD.	21 / G	0.25	6.35	0.38	9.53	1.55	39.37	1.53	38.86	1.25	31.75	1.10	27.94
		A								2.53	64.26				
		B								3.53	89.66				
		C								4.53	115.06				
	04	STD.		0.38	9.53	0.50	12.70			1.53	38.86	1.25	31.75	1.20	30.48
		A								2.53	64.26				
		B								3.53	89.66				
		C								4.53	115.06				
	05	STD.		0.50	12.70	0.63	15.88			1.53	38.86	1.31	33.27	1.25	31.75
		A								2.53	64.26				
		B								3.53	89.66				
		C								4.53	115.06				
	06	STD.		0.63	15.88	0.75	19.05			1.53	38.86	1.38	35.05	1.40	35.56
		A								2.53	64.26				
		B								3.53	89.66				
		C								4.53	115.06				
	07	STD.		0.75	19.05	0.88	22.23			1.53	38.86	1.50	38.10	1.50	38.10
		A								2.53	64.26				
		B								3.53	89.66				
		C								4.53	115.06				
	08	STD.		0.88	22.23	1.00	25.40			1.53	38.86	1.63	41.40	1.65	41.91
		A								2.53	64.26				
		B								3.53	89.66				
		C								4.53	115.06				
23	03	STD.	23 / H	0.25	6.35	0.38	9.53	1.65	41.91	1.53	38.86	1.25	31.75	1.10	27.94
		A								2.53	64.26				
		B								3.53	89.66				
		C								4.53	115.06				
	04	STD.		0.38	9.53	0.50	12.70			1.53	38.86	1.25	31.75	1.20	30.48
		A								2.53	64.26				
		B								3.53	89.66				
		C								4.53	115.06				
	05	STD.		0.50	12.70	0.63	15.88			1.53	38.86	1.31	33.27	1.25	31.75
		A								2.53	64.26				
		B								3.53	89.66				
		C								4.53	115.06				
06	STD.	0.63	15.88	0.75	19.05	1.53	38.86	1.38	35.05	1.40	35.56				
	A					2.53	64.26								
	B					3.53	89.66								
	C					4.53	115.06								

Table continued

STRAIGHT; SPIN COUPLING 38999 Series III, IV

MIL PART NUMBER DESIGNATOR			CONNECTOR SHELL SIZE/CODE (REF.)	CABLE RANGE				A DIA. (MAX)		B (MAX)		X (MAX)		Y (MAX)	
CONNECTOR SHELL SIZE	CLAMP SIZE	LENGTH CODE		MIN		MAX		INCH	MM	INCH	MM	INCH	MM	INCH	MM
				INCH	MM	INCH	MM								
23, cont.	07	STD.	23 / H	0.75	19.05	0.88	22.23	1.65	41.91	1.53	38.86	1.50	38.10	1.50	38.10
		A								2.53	64.26				
		B								3.53	89.66				
		C								4.53	115.06				
	08	STD.		0.88	22.23	1.00	25.40			1.53	38.86	1.63	41.40	1.65	42.91
		A								2.53	64.26				
		B								3.53	89.66				
		C								4.53	115.06				
	09	STD.		1.00	25.40	1.13	28.58			1.53	38.86	1.63	41.40	1.75	44.45
		A								2.53	64.26				
		B								3.53	89.66				
		C								4.53	115.06				
25	04	STD.	25 / J	0.38	9.53	0.50	12.70	1.85	46.99	1.53	38.86	1.25	31.75	1.20	30.48
		A								2.53	64.26				
		B								3.53	89.66				
		C								4.53	115.06				
	05	STD.		0.50	12.70	0.63	15.88			1.53	38.86	1.31	33.27	1.25	31.75
		A								2.53	64.26				
		B								3.53	89.66				
		C								4.53	115.06				
	06	STD.		0.63	15.88	0.75	19.05			1.53	38.86	1.38	35.05	1.40	35.56
		A								2.53	64.26				
		B								3.53	89.66				
		C								4.53	115.06				
	07	STD.		0.75	19.05	0.88	22.23			1.53	38.86	1.50	38.10	1.50	38.10
		A								2.53	64.26				
		B								3.53	89.66				
		C								4.53	115.06				
	08	STD.		0.88	22.23	1.00	25.40			1.53	38.86	1.63	41.40	1.65	41.91
		A								2.53	64.26				
		B								3.53	89.66				
		C								4.53	115.06				
	09	STD.		1.00	25.40	1.13	28.58			1.53	38.86	1.63	41.40	1.75	44.45
		A								2.53	64.26				
		B								3.53	89.66				
		C								4.53	115.06				
10	STD.	1.13	28.58	1.25	31.75	1.53	38.86	1.63	41.40	1.90	48.26				
	A					2.53	64.26								
	B					3.53	89.66								
	C					4.53	115.06								

90° & 45°; SPIN COUPLING 38999 Series III, IV

MIL Part Number

M85049	/79	11	W	03
Series	Slash Sheet	Shell Size (Table B)	Finish (Table 2, pg. 14)	Clamp Size (Table B)
	78: 45° 79: 90°			

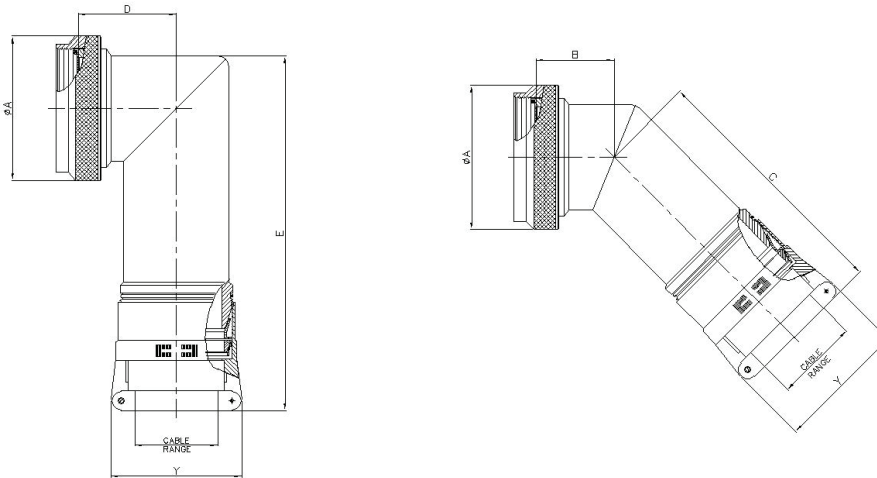

TABLE - B

MIL PART NUMBER DESIGNATOR		CONNECTOR SHELL SIZE/ CODE (REF.)	CABLE RANGE				A DIA. (MAX)		B (MAX)		C (MAX)		D (MAX)		E (MAX)		Y (MAX)	
CONNECTOR SHELL SIZE	CLAMP SIZE		MIN		MAX		INCH	MM	INCH	MM	INCH	MM	INCH	MM	INCH	MM	INCH	MM
			INCH	MM	INCH	MM												
9	01	09 / A	0.06	1.57	0.13	3.18	0.75	19.05	0.46	11.68	3.15	80.01	0.69	17.53	3.46	87.88	0.80	20.32
	02		0.13	3.18	0.25	6.35											1.00	25.40
11	01	11 / B	0.06	1.57	0.13	3.18	0.85	21.59	0.52	13.21	3.21	81.53	0.78	19.81	3.58	90.93	0.80	20.32
	02		0.13	3.18	0.25	6.35											1.10	27.94
	03		0.25	6.35	0.38	9.53											1.20	30.48
13	02	13 / C	0.13	3.18	0.25	6.35	1.00	25.40	0.58	14.73	3.27	83.06	0.80	20.32	3.60	91.44	1.00	25.40
	03		0.25	6.35	0.38	9.53											1.10	27.94
	04		0.38	9.53	0.50	12.70											1.20	30.48
15	02	15 / D	0.13	3.18	0.25	6.35	1.15	29.21	0.65	16.51	3.36	85.34	0.88	22.35	3.67	93.22	1.00	25.40
	03		0.25	6.35	0.38	9.53											1.10	27.94
	04		0.38	9.53	0.50	12.70											1.20	30.48
	05		0.50	12.70	0.63	15.88											1.25	31.75
17	02	17 / E	0.13	3.18	0.25	6.35	1.25	31.75	0.74	18.80	3.47	88.14	0.93	23.62	3.76	95.50	1.00	25.40
	03		0.25	6.35	0.38	9.53											1.10	27.94
	04		0.38	9.53	0.50	12.70											1.20	30.48
	05		0.50	12.70	0.63	15.88											1.25	31.75
	06		0.63	15.88	0.75	19.05											1.40	35.56

Table continued

90° & 45°; SPIN COUPLING 38999 Series III, IV

TABLE – B, cont.

MIL PART NUMBER DESIGNATOR		CONNECTOR SHELL SIZE/ CODE (REF.)	CABLE RANGE				A DIA. (MAX)		B (MAX)		C (MAX)		D (MAX)		E (MAX)		Y (MAX)	
CONNECTOR SHELL SIZE	CLAMP SIZE		MIN		MAX		INCH	MM	INCH	MM	INCH	MM	INCH	MM	INCH	MM	INCH	MM
			INCH	MM	INCH	MM												
19	03	19 / F	0.25	6.35	0.38	9.53	1.40	35.56	0.93	23.62	3.66	92.96	1.01	25.65	3.93	99.82	1.10	27.94
	04		0.38	9.53	0.50	12.70											1.20	30.48
	05		0.50	12.70	0.63	15.88											1.25	31.75
	06		0.63	15.88	0.75	19.05											1.40	35.56
	07		0.75	19.05	0.88	22.23											1.50	38.10
21	03	21 / G	0.25	6.35	0.38	9.53	1.55	39.37	0.93	23.62	3.66	92.96	1.06	26.92	3.93	99.82	1.10	27.94
	04		0.38	9.53	0.50	12.70											1.20	30.48
	05		0.50	12.70	0.63	15.88											1.25	31.75
	06		0.63	15.88	0.75	19.05											1.40	35.56
	07		0.75	19.05	0.88	22.23											1.50	38.10
	08		0.88	22.23	1.00	25.40											1.65	41.91
23	03	23 / H	0.25	6.35	0.38	9.53	1.65	41.91	1.02	25.91	3.81	96.77	1.17	29.72	4.04	102.62	1.10	27.94
	04		0.38	9.53	0.50	12.70											1.20	30.48
	05		0.50	12.70	0.63	15.88											1.25	31.75
	06		0.63	15.88	0.75	19.05											1.40	35.56
	07		0.75	19.05	0.88	22.23											1.50	38.10
	08		0.88	22.23	1.00	25.40											1.65	41.91
	09		1.00	25.40	1.13	28.58											1.75	44.45
25	04	25 / J	0.38	9.53	0.50	12.70	1.85	46.99	1.02	25.91	3.81	96.77	1.18	29.97	4.04	102.62	1.20	30.48
	05		0.50	12.70	0.63	15.88											1.25	31.75
	06		0.63	15.88	0.75	19.05											1.40	35.56
	07		0.75	19.05	0.88	22.23											1.50	38.10
	08		0.88	22.23	1.00	25.40											1.65	41.91
	09		1.00	25.40	1.13	28.58											1.75	44.45
	10		1.13	28.58	1.25	31.75											1.90	48.26

STRAIGHT; SELF-LOCK/NON SELF-LOCK

26482 Series II; 5015 (MS345X); 83723 Series III

MIL Part Number

M85049	/31	-	10	W
Series	Slash Sheet	Coupling	Dash Number (Table A)	Finish (Table 2, pg. 14)
	31: Straight	S: Self Lock -: Non Self-Lock		

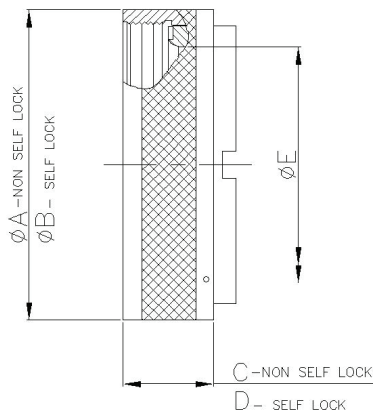

TABLE-A							
MIL PART NUMBER DESIGNATOR	CONNECTOR SHELL SIZE	A DIA. (MAX)		B DIA. (MAX)		C (MAX)	
		INCH	MM	INCH	MM	INCH	MM
08	8	0.69	17.48	0.66	16.69	0.54	13.72
10	10	0.80	20.40	0.77	19.66	0.54	13.72
12	7/12	0.94	23.83	0.90	22.81	0.54	13.72
14	12/14	1.06	27.00	1.02	26.01	0.54	13.72
16	19/16	1.24	31.45	1.15	29.26	0.54	13.72
18	27/18	1.31	33.27	1.24	31.57	0.54	13.72
20	37/20	1.44	36.47	1.37	34.80	0.54	13.72
22	22	1.56	39.62	1.44	36.65	0.54	13.72
24	24	1.69	42.82	1.62	41.10	0.54	13.72
28	28	2.06	52.37	1.97	50.01	0.70	17.83
32	32	2.31	58.72	2.22	56.36	0.70	17.83
36	36	2.56	65.07	2.47	62.71	0.70	17.83
40	40	2.81	71.42	2.72	69.06	0.70	17.83
44	44	3.06	77.77	2.97	75.41	0.70	17.83
48	48	3.31	84.12	3.22	81.76	0.70	17.83

STRAIGHT; SELF-LOCK/NON SELF-LOCK

38999 Series I & Series II

MIL Part Number

M85049	/27	-	10	W
Series	Slash Sheet	Coupling	Dash Number (Table A)	Finish (Table 2, pg. 14)
	27: Straight	S: Self Lock -: Non Self-Lock		

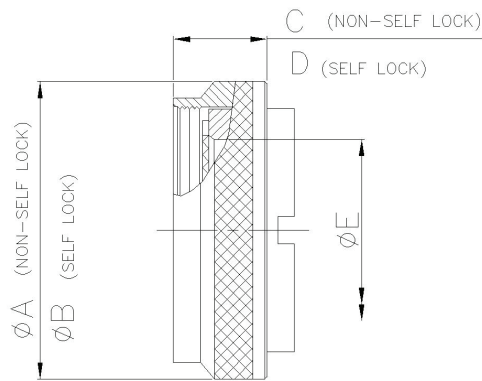

TABLE-A											
MIL PART NUMBER DESIGNATOR	CONNECTOR SHELL SIZE SE-II/I	A DIA. (MAX)		B DIA. (MAX)		C (MAX)		D (MAX)		E DIA. (MAX)	
		INCH	MM	INCH	MM	INCH	MM	INCH	MM	INCH	MM
DASH NO.											
08	8 / 9	0.75	19.05	0.86	21.82	0.54	13.72	0.59	14.99	0.27	6.86
10	10 / 11	0.85	21.59	0.98	24.99	0.54	13.72	0.59	14.99	0.41	10.41
12	12 / 13	1.00	25.40	1.16	29.36	0.54	13.72	0.59	14.99	0.53	13.46
14	14 / 15	1.10	27.94	1.28	32.54	0.54	13.72	0.59	14.99	0.65	16.51
16	16 / 17	1.25	31.75	1.41	35.71	0.54	13.72	0.59	14.99	0.78	19.81
18	18 / 19	1.40	35.56	1.52	38.51	0.54	13.72	0.59	14.99	0.88	22.35
20	20 / 21	1.50	38.10	1.64	41.68	0.54	13.72	0.59	14.99	1.01	25.65
22	22 / 23	1.65	41.91	1.77	44.86	0.54	13.72	0.59	14.99	1.13	28.70
24	24 / 25	1.75	44.45	1.89	48.03	0.54	13.72	0.59	14.99	1.26	32.00

STRAIGHT; SELF-LOCK/NON SELF-LOCK

38999 Series III & Series IV

MIL Part Number

M85049	/14	-	11	W
Series	Slash Sheet	Coupling	Dash Number (Table A)	Finish (Table 2, pg. 14)
	14: Straight	S: Self Lock -: Non Self-Lock		

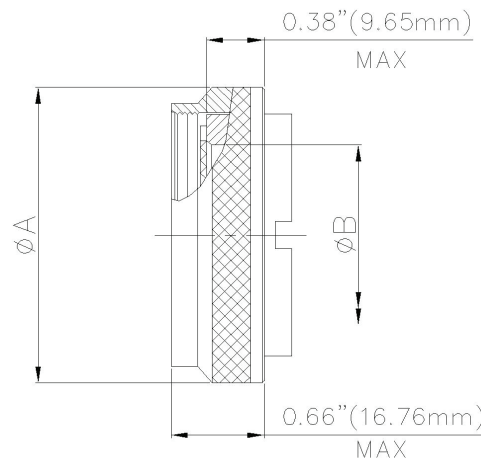

MIL PART NUMBER DESIGNATOR	CONNECTOR SHELL SIZE/ CODE (REF.)	A DIA.(MAX)		B (MAX)	
		INCH	MM	INCH	MM
9	09 / A	0.86	21.79	0.26	6.71
11	11 / B	0.98	24.99	0.39	9.91
13	13 / C	1.16	29.39	0.50	12.80
15	15 / D	1.28	32.49	0.63	16.00
17	17 / E	1.41	35.71	0.76	19.20
19	19 / F	1.52	38.51	0.84	21.41
21	21 / G	1.64	41.71	0.97	24.64
23	23 / H	1.77	44.91	1.09	27.71
25	25 / J	1.87	47.98	1.22	30.91

STRAIGHT, DIRECT COUPLING

38999 Series I & Series II

MIL Part Number

M85049	/29	10	W	06	A
Series	Slash Sheet	Shell Size (Table A)	Finish (Table 2, pg. 14)	Clamp x Size (Table A)	Length (Table A) Omit for "STD"
	29: Straight				

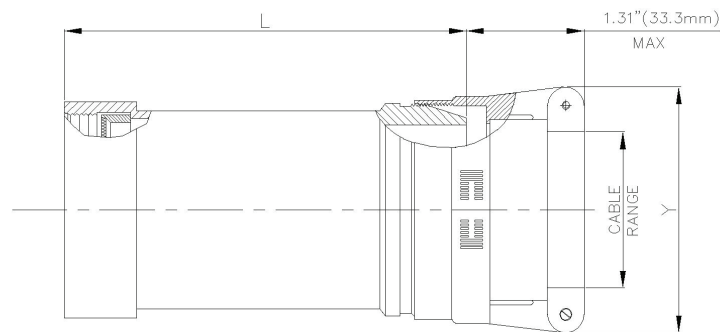

MIL PART NUMBER DESIGNATOR			CONNECTOR SHELL SIZE SE - II / I	CABLE RANGE				L (MAX)		Y (MAX)		
ACCESSORY SHELL SIZE	CLAMP SIZE	LENGTH		MIN		MAX		INCH	MM	INCH	MM	
				INCH	MM	INCH	MM					
08	01	STD.	8 / 9	0.06	1.57	0.13	3.18	1.03	26.16	0.78	19.81	
		A						2.03	51.56			
	02	STD.		0.13	3.18	0.25	6.35	1.03	26.16	0.97	24.64	
		A						2.03	51.56			
10	01	STD.	10 / 11	0.06	1.57	0.13	3.18	1.03	26.16	0.78	19.81	
		A						2.03	51.56			
	02	STD.		0.13	3.18	0.25	6.35	1.03	26.16	0.97	24.64	
		A						2.03	51.56			
	03	STD.		0.25	6.35	0.38	9.53	1.03	26.16	1.06	26.92	
		A						2.03	51.56			
12	02	STD.	12 / 13	0.13	3.18	0.25	6.35	1.03	26.16	0.97	24.64	
		A						2.03	51.56			
	03	STD.		0.25	6.35	0.38	9.53	1.03	26.16	1.06	26.92	
		A						2.03	51.56			
14	02	STD.	14 / 15	0.13	3.18	0.25	6.35	1.03	26.16	0.97	24.64	
		A						2.03	51.56			
	03	STD.		0.25	6.35	0.38	9.53	1.03	26.16	1.06	26.92	
		A						2.03	51.56			
04	STD.	0.31		7.92	0.50	12.70	1.03	26.16	1.16	29.46		
	A						2.03	51.56				
05	STD.	0.44		11.10	0.63	15.88	1.03	26.16	1.25	31.75		
	A						2.03	51.56				
									3.03	76.96		

Table continued

STRAIGHT, DIRECT COUPLING 38999 Series I & Series II

MIL PART NUMBER DESIGNATOR			CONNECTOR SHELL SIZE SE - II / I	CABLE RANGE				L (MAX)		Y (MAX)	
ACCESSORY SHELL SIZE	CLAMP SIZE	LENGTH		MIN		MAX		INCH	MM	INCH	MM
				INCH	MM	INCH	MM				
16	02	STD.	16 / 17	0.13	3.18	0.25	6.35	1.03	26.16	0.97	24.64
		A						2.03	51.56		
		B						3.03	76.96		
	03	STD.		0.25	6.35	0.38	9.53	1.03	26.16	1.06	26.92
		A						2.03	51.56		
		B						3.03	76.96		
	04	STD.		0.31	7.92	0.50	12.70	1.03	26.16	1.16	29.46
		A						2.03	51.56		
		B						3.03	76.96		
	05	STD.		0.44	11.10	0.63	15.88	1.03	26.16	1.25	31.75
		A						2.03	51.56		
		B						3.03	76.96		
06	STD.	0.56	14.27	0.75	19.05	1.03	26.16	1.38	35.05		
	A					2.03	51.56				
	B					3.03	76.96				
18	03	STD.	18 / 19	0.25	6.35	0.38	9.53	1.03	26.16	1.06	26.92
		A						2.03	51.56		
		B						3.03	76.96		
	04	STD.		0.31	7.92	0.50	12.70	1.03	26.16	1.16	29.46
		A						2.03	51.56		
		B						3.03	76.96		
	05	STD.		0.44	11.10	0.63	15.88	1.03	26.16	1.25	31.75
		A						2.03	51.56		
		B						3.03	76.96		
	06	STD.		0.56	14.27	0.75	19.05	1.03	26.16	1.38	35.05
		A						2.03	51.56		
		B						3.03	76.96		
07	STD.	0.69	17.45	0.88	22.23	1.03	26.16	1.50	38.10		
	A					2.03	51.56				
	B					3.03	76.96				
20	03	STD.	20 / 21	0.25	6.35	0.38	9.53	1.03	26.16	1.06	26.92
		A						2.03	51.56		
		B						3.03	76.96		
		C						4.03	102.36		
	04	STD.		0.31	7.92	0.50	12.70	1.03	26.16	1.16	29.46
		A						2.03	51.56		
		B						3.03	76.96		
		C						4.03	102.36		
	05	STD.		0.44	11.10	0.63	15.88	1.03	26.16	1.25	31.75
		A						2.03	51.56		
		B						3.03	76.96		
		C						4.03	102.36		
	06	STD.		0.56	14.27	0.75	19.05	1.03	26.16	1.38	35.05
		A						2.03	51.56		
		B						3.03	76.96		
		C						4.03	102.36		
	07	STD.		0.69	17.45	0.88	22.23	1.03	26.16	1.50	38.10
		A						2.03	51.56		
		B						3.03	76.96		
		C						4.03	102.36		
	08	STD.		0.81	20.62	1.00	25.40	1.03	26.16	1.63	41.40
		A						2.03	51.56		
		B						3.03	76.96		
		C						4.03	102.36		

Table continued

STRAIGHT, DIRECT COUPLING

38999 Series I & Series II

MIL PART NUMBER DESIGNATOR			CONNECTOR SHELL SIZE SE - II / I	CABLE RANGE				L (MAX)		Y (MAX)	
ACCESSORY SHELL SIZE	CLAMP SIZE	LENGTH		MIN		MAX		INCH	MM	INCH	MM
				INCH	MM	INCH	MM				
22	03	STD.	22 / 23	0.25	6.35	0.38	9.53	1.03	26.16	1.06	26.92
		A						2.03	51.56		
		B						3.03	76.96		
		C						4.03	102.36		
	04	STD.		0.31	7.92	0.50	12.70	1.03	26.16	1.16	29.46
		A						2.03	51.56		
		B						3.03	76.96		
		C						4.03	102.36		
	05	STD.		0.44	11.10	0.63	15.88	1.03	26.16	1.25	31.75
		A						2.03	51.56		
		B						3.03	76.96		
		C						4.03	102.36		
	06	STD.		0.56	14.27	0.75	19.05	1.03	26.16	1.38	35.05
		A						2.03	51.56		
		B						3.03	76.96		
		C						4.03	102.36		
	07	STD.		0.69	17.45	0.88	22.23	1.03	26.16	1.50	38.10
		A						2.03	51.56		
		B						3.03	76.96		
		C						4.03	102.36		
	08	STD.		0.81	20.62	1.00	25.40	1.03	26.16	1.63	41.40
		A						2.03	51.56		
		B						3.03	76.96		
		C						4.03	102.36		
	09	STD.		0.94	23.80	1.13	28.58	1.03	26.16	1.75	44.45
		A						2.03	51.56		
		B						3.03	76.96		
		C						4.03	102.36		
24	04	STD.	24 / 25	0.31	7.92	0.50	12.70	1.03	26.16	1.16	29.46
		A						2.03	51.56		
		B						3.03	76.96		
		C						4.03	102.36		
	05	STD.		0.44	11.10	0.63	15.88	1.03	26.16	1.25	31.75
		A						2.03	51.56		
		B						3.03	76.96		
		C						4.03	102.36		
	06	STD.		0.56	14.27	0.75	19.05	1.03	26.16	1.38	35.05
		A						2.03	51.56		
		B						3.03	76.96		
		C						4.03	102.36		
	07	STD.		0.69	17.45	0.88	22.23	1.03	26.16	1.50	38.10
		A						2.03	51.56		
		B						3.03	76.96		
		C						4.03	102.36		
	08	STD.		0.81	20.62	1.00	25.40	1.03	26.16	1.63	41.40
		A						2.03	51.56		
		B						3.03	76.96		
		C						4.03	102.36		
	09	STD.		0.94	23.80	1.13	28.58	1.03	26.16	1.75	44.45
		A						2.03	51.56		
		B						3.03	76.96		
		C						4.03	102.36		
	10	STD.		1.06	26.97	1.25	31.75	1.03	26.16	1.88	47.75
		A						2.03	51.56		
		B						3.03	76.96		
		C						4.03	102.36		

STRAIGHT, SPIN COUPLING

38999 Series III, IV

MIL Part Number

M85049	/21	11	W	02	A
Series	Slash Sheet	Shell Size (Table A)	Finish (Table 2, pg. 14)	Clamp x Size (Table A)	Length (Table A) Omit for "STD"
	21: Straight				

*Example shown on pg. 5 (M85049/211W02A)

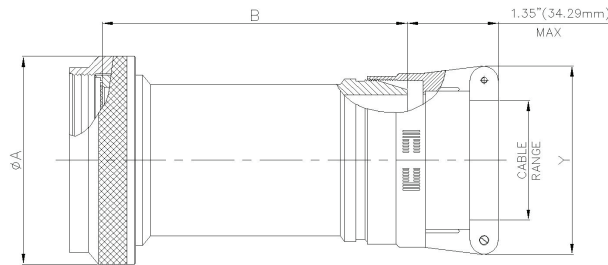

TABLE - A

MIL PART NUMBER DESIGNATOR			CONNECTOR SHELL SIZE/CODE (REF.)	CABLE RANGE				A DIA. (MAX)		B (MAX)		Y (MAX)	
CONNECTOR SHELL SIZE	CLAMP SIZE	LENGTH		MIN		MAX		INCH	MM	INCH	MM	INCH	MM
				INCH	MM	INCH	MM						
9	01	STD.	09 / A	0.06	1.57	0.13	3.18	0.75	19.05	1.53	38.86	0.80	20.32
		A								2.53	64.26		
	02	STD.		0.13	3.18	0.25	6.35			1.53	38.86	1.00	25.40
		A		2.53	64.26								
11	01	STD.	11 / B	0.06	1.57	0.13	3.18	0.85	21.59	1.53	38.86	0.80	20.32
		A								2.53	64.26		
	02	STD.		0.13	3.18	0.25	6.35			1.53	38.86	1.00	25.40
		A		2.53	64.26								
13	03	STD.	13 / C	0.25	6.35	0.38	9.53	1.00	25.40	1.53	38.86	1.10	27.94
		A								2.53	64.26		
	04	STD.		0.31	7.92	0.50	12.70			1.53	38.86	1.20	30.48
		A		2.53	64.26								
15	02	STD.	15 / D	0.13	3.18	0.25	6.35	1.10	27.94	1.53	38.86	1.00	25.40
		A								2.53	64.26		
		B								3.53	89.66		
		B								1.53	38.86		
	03	STD.		0.25	6.35	0.38	9.53			2.53	64.26	1.10	27.94
		A								3.53	89.66		
		B								1.53	38.86		
		B								2.53	64.26		
04	STD.	0.31	7.92	0.50	12.70	1.53	38.86	1.20	30.48				
	A					2.53	64.26						
	B					3.53	89.66						
	B					1.53	38.86						
17	02	STD.	17 / E	0.13	3.18	0.25	6.35	1.25	31.75	1.53	38.86	1.00	25.40
		A								2.53	64.26		
		B								3.53	89.66		
		B								1.53	38.86		
	03	STD.		0.25	6.35	0.38	9.53			2.53	64.26	1.10	27.94
		A								3.53	89.66		
		B								1.53	38.86		
		B								2.53	64.26		
04	STD.	0.31	7.92	0.50	12.70	1.53	38.86	1.20	30.48				
	A					2.53	64.26						
	B					3.53	89.66						
	B					1.53	38.86						

Table continued

STRAIGHT, SPIN COUPLING 38999 Series III, IV

TABLE - A, Cont.																	
MIL PART NUMBER DESIGNATOR			CONNECTOR SHELL SIZE/CODE (REF.)	CABLE RANGE				A DIA. (MAX)		B (MAX)		Y (MAX)					
CONNECTOR SHELL SIZE	CLAMP SIZE	LENGTH		MIN		MAX		INCH	MM	INCH	MM	INCH	MM				
				INCH	MM	INCH	MM										
17, cont.	05	STD.	17/E	0.44	11.10	0.63	15.88	1.25	31.75	1.53	38.86	1.25	31.75				
		A								2.53	64.26						
		B								3.53	89.66						
	06	STD.		0.56	14.27	0.75	19.05			1.53	38.86	1.40	35.56				
		A								2.53	64.26						
		B								3.53	89.66						
19	03	STD.	19 / F	0.25	6.35	0.38	9.53	1.40	35.56	1.53	38.86	1.10	27.94				
		A								2.53	64.26						
		B								3.53	89.66						
	04	STD.		0.31	7.92	0.50	12.70			1.53	38.86	1.20	30.48				
		A								2.53	64.26						
		B								3.53	89.66						
	05	STD.		0.44	11.10	0.63	15.88			1.53	38.86	1.25	31.75				
		A								2.53	64.26						
		B								3.53	89.66						
	06	STD.		0.56	14.27	0.75	19.05			1.53	38.86	1.40	35.56				
		A								2.53	64.26						
		B								3.53	89.66						
	07	STD.		0.69	17.45	0.88	22.23			1.53	38.86	1.50	38.10				
		A								2.53	64.26						
		B								3.53	89.66						
	21	03		STD.	21 / G	0.25	6.35			0.38	9.53	1.50	38.10	1.53	38.86	1.10	27.94
				A										2.53	64.26		
				B										3.53	89.66		
C			4.53	115.06													
04		STD.	0.31	7.92		0.50	12.70	1.53	38.86	1.20	30.48						
		A						2.53	64.26								
		B						3.53	89.66								
		C						4.53	115.06								
05		STD.	0.44	11.10		0.63	15.88	1.53	38.86	1.25	31.75						
		A						2.53	64.26								
		B						3.53	89.66								
		C						4.53	115.06								
06		STD.	0.56	14.27		0.75	19.05	1.53	38.86	1.40	35.56						
		A						2.53	64.26								
		B						3.53	89.66								
		C						4.53	115.06								
07		STD.	0.69	17.45		0.88	22.23	1.53	38.86	1.50	38.10						
		A						2.53	64.26								
		B						3.53	89.66								
		C						4.53	115.06								
08		STD.	0.81	20.62		1.00	25.40	1.53	38.86	1.65	41.91						
		A						2.53	64.26								
		B						3.53	89.66								
		C						4.53	115.06								
23	03	STD.	23 / H	0.25	6.35	0.38	9.53	1.65	41.91	1.53	38.86	1.10	27.94				
		A								2.53	64.26						
		B								3.53	89.66						
		C								4.53	115.06						

Table continued

STRAIGHT, SPIN COUPLING
38999 Series III, IV

TABLE - A

MIL PART NUMBER DESIGNATOR			CONNECTOR SHELL SIZE/CODE (REF.)	CABLE RANGE				A DIA. (MAX)		B (MAX)		Y (MAX)	
CONNECTOR SHELL SIZE	CLAMP SIZE	LENGTH		MIN		MAX		INCH	MM	INCH	MM	INCH	MM
				INCH	MM	INCH	MM						
23, cont.	04	STD.	23 / H	0.31	7.92	0.50	12.70	1.65	41.91	1.20	30.48	1.53	38.86
		A										2.53	64.26
		B										3.53	89.66
		C										4.53	115.06
	05	STD.		0.44	11.10	0.63	15.88			1.25	31.75	1.53	38.86
		A										2.53	64.26
		B										3.53	89.66
		C										4.53	115.06
	06	STD.		0.56	14.27	0.75	19.05			1.40	35.56	1.53	38.86
		A										2.53	64.26
		B										3.53	89.66
		C										4.53	115.06
	07	STD.		0.69	17.45	0.88	22.23			1.50	38.10	1.53	38.86
		A										2.53	64.26
		B										3.53	89.66
		C										4.53	115.06
	08	STD.		0.81	20.62	1.00	25.40			1.65	41.91	1.53	38.86
		A										2.53	64.26
		B										3.53	89.66
		C										4.53	115.06
	09	STD.		0.94	23.80	1.13	28.58			1.75	44.45	1.53	38.86
		A										2.53	64.26
		B										3.53	89.66
		C										4.53	115.06
25	04	STD.	25 / J	0.31	7.92	0.50	12.70	1.75	44.45	1.20	30.48	1.53	38.86
		A										2.53	64.26
		B										3.53	89.66
		C										4.53	115.06
	05	STD.		0.44	11.10	0.63	15.88			1.25	31.75	1.53	38.86
		A										2.53	64.26
		B										3.53	89.66
		C										4.53	115.06
	06	STD.		0.56	14.27	0.75	19.05			1.40	35.56	1.53	38.86
		A										2.53	64.26
		B										3.53	89.66
		C										4.53	115.06
	07	STD.		0.69	17.45	0.88	22.23			1.50	38.10	1.53	38.86
		A										2.53	64.26
		B										3.53	89.66
		C										4.53	115.06
	08	STD.		0.81	20.62	1.00	25.40			1.65	41.91	1.53	38.86
		A										2.53	64.26
		B										3.53	89.66
		C										4.53	115.06
	09	STD.		0.94	23.80	1.13	28.58			1.75	44.45	1.53	38.86
		A										2.53	64.26
		B										3.53	89.66
		C										4.53	115.06
10	STD.	1.06	26.97	1.25	31.75	1.90	48.26	1.53	38.86				
	A							2.53	64.26				
	B							3.53	89.66				
	C							4.53	115.06				

STRAIGHT, SPIN COUPLING

26482 Series II; 5015 (MS345X); 83723 Series III

MIL Part Number

M85049	/25	-102	W
Series	Slash Sheet	Dash Number (Table A)	Finish (Table 2, pg. 14)
	25 :Straight Spin Coupling		

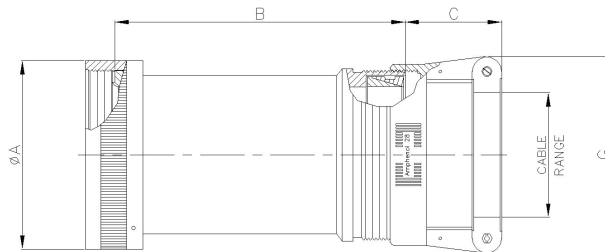

MIL PART NUMBER DESIGNATOR		CONNECTOR SHELL SIZE	TABLE-A											
SHELL SIZE	DASH NO		A DIA. (MAX)		B (MAX)		C (REF) L MAX		G (MAX) L MAX		CABLE RANGE			
			INCH	MM	INCH	MM	INCH	MM	INCH	MM	MIN WIRE		MAX WIRE	
										INCH	MM	INCH	MM	
8	05	8	0.62	15.67	2.13	54.10	1.03	26.09	0.96	24.31	0.13	3.18	0.25	6.35
	06		0.62	15.67	3.13	79.50	1.03	26.09	0.96	24.31	0.13	3.18	0.25	6.35
	07*		0.62	15.67	2.88	73.15	1.03	26.09	1.15	29.08	0.25	6.35	0.44	11.10
	08*		0.62	15.67	3.88	98.55	1.03	26.09	1.15	29.08	0.25	6.35	0.44	11.10
10	09	10	0.73	18.64	2.13	54.10	1.03	26.09	0.96	24.31	0.13	3.18	0.31	7.92
	10		0.73	18.64	3.13	79.50	1.03	26.09	0.96	24.31	0.13	3.18	0.31	7.92
	11*		0.73	18.64	2.88	73.15	1.03	26.09	1.15	29.08	0.25	6.35	0.44	11.10
	12*		0.73	18.64	3.88	98.55	1.03	26.09	1.15	29.08	0.25	6.35	0.44	11.10
	136		0.73	18.64	2.13	54.10	1.03	26.09	1.15	29.08	0.25	6.35	0.38	9.53
	137		0.73	18.64	3.13	79.50	1.03	26.09	1.15	29.08	0.25	6.35	0.38	9.53
12	13	7/12	0.86	21.79	2.13	54.10	1.03	26.09	1.15	29.08	0.25	6.35	0.44	11.10
	14		0.86	21.79	3.13	79.50	1.03	26.09	1.15	29.08	0.25	6.35	0.44	11.10
	15*		0.86	21.79	2.88	73.15	1.03	26.09	1.33	33.83	0.35	8.89	0.63	15.88
	16*		0.86	21.79	3.88	98.55	1.03	26.09	1.33	33.83	0.35	8.89	0.63	15.88
	111		0.86	21.79	2.13	54.10	1.03	26.09	1.33	33.83	0.35	8.89	0.50	12.70
	114		0.86	21.79	2.13	54.10	1.03	26.09	0.96	24.31	0.13	3.18	0.31	7.92
	115		0.86	21.79	3.13	79.50	1.03	26.09	0.96	24.31	0.13	3.18	0.31	7.92
	138		0.86	21.79	2.13	54.10	1.03	26.09	1.33	33.83	0.35	8.89	0.50	12.70
	139		0.86	21.79	3.13	79.50	1.03	26.09	1.33	33.83	0.35	8.89	0.50	12.70
14	17	12/14	0.98	24.99	2.13	54.10	1.03	26.09	1.33	33.83	0.35	8.89	0.58	14.61
	18		0.98	24.99	3.13	79.50	1.03	26.09	1.33	33.83	0.35	8.89	0.58	14.61
	19*		0.98	24.99	2.88	73.15	1.06	26.90	1.55	39.40	0.50	12.70	0.75	19.05
	20*		0.98	24.99	3.88	98.55	1.06	26.90	1.55	39.40	0.50	12.70	0.75	19.05
	116		0.98	24.99	2.13	54.10	1.03	26.09	1.15	29.08	0.25	6.35	0.44	11.10
	117		0.98	24.99	3.13	79.50	1.03	26.09	1.15	29.08	0.25	6.35	0.44	11.10
	150		0.98	24.99	2.13	54.10	1.03	26.09	0.96	24.31	0.13	3.18	0.31	7.92
	151		0.98	24.99	3.13	79.50	1.03	26.09	0.96	24.31	0.13	3.18	0.31	7.92
16	21	19/16	1.11	28.24	2.13	54.10	1.06	26.90	1.55	39.40	0.50	12.70	0.70	17.78
	22		1.11	28.24	3.13	79.50	1.06	26.90	1.55	39.40	0.50	12.70	0.70	17.78
	23*		1.11	28.24	2.88	73.15	1.16	29.36	1.77	44.96	0.63	15.88	0.94	23.80
	24*		1.11	28.24	3.88	98.55	1.16	29.36	1.77	44.96	0.63	15.88	0.94	23.80
	112		1.11	28.24	2.13	54.10	1.03	26.09	1.15	29.08	0.25	6.35	0.44	11.10
	113		1.11	28.24	3.13	79.50	1.03	26.09	1.15	29.08	0.25	6.35	0.44	11.10
	118		1.11	28.24	2.13	54.10	1.03	26.09	1.33	33.83	0.35	8.89	0.63	15.88
	119		1.11	28.24	3.13	79.50	1.03	26.09	1.33	33.83	0.35	8.89	0.63	15.88
	152		1.11	28.24	2.13	54.10	1.03	26.09	0.96	24.31	0.13	3.18	0.31	7.92
	153		1.11	28.24	3.13	79.50	1.03	26.09	0.96	24.31	0.13	3.18	0.31	7.92

(*)Denotes Style-2
Table continued

NON-ENVIRONMENTAL EMI/RFI

STRAIGHT, SPIN COUPLING

26482 Series II; 5015 (MS345X); 83723 Series III

MIL PART NUMBER DESIGNATOR		CONNECTOR SHELL SIZE	TABLE-A											
SHELL SIZE	DASH NO		A DIA. (MAX)		B (MAX)		C (REF) L MAX		G (MAX) L MAX		CABLE RANGE			
			INCH	MM	INCH	MM	INCH	MM	INCH	MM	MIN WIRE		MAX WIRE	
											INCH	MM	INCH	MM
18	25	27/18	1.22	30.94	2.13	54.10	1.03	26.09	1.33	33.83	0.35	8.89	0.63	15.88
	26		1.22	30.94	3.13	79.50	1.03	26.09	1.33	33.83	0.35	8.89	0.63	15.88
	27		1.22	30.94	2.13	54.10	1.06	26.90	1.55	39.40	0.50	12.70	0.75	19.05
	28		1.22	30.94	3.13	79.50	1.06	26.90	1.55	39.40	0.50	12.70	0.75	19.05
	29*		1.22	30.94	2.88	73.15	1.16	29.36	1.77	44.96	0.63	15.88	0.94	23.80
	30*		1.22	30.94	3.88	98.55	1.16	29.36	1.77	44.96	0.63	15.88	0.94	23.80
	120		1.22	30.94	2.13	54.10	1.03	26.09	0.96	24.31	0.13	3.18	0.31	7.92
	121		1.22	30.94	3.13	79.50	1.03	26.09	0.96	24.31	0.13	3.18	0.31	7.92
	122		1.22	30.94	2.13	54.10	1.03	26.09	1.15	29.08	0.25	6.35	0.44	11.10
	123		1.22	30.94	3.13	79.50	1.03	26.09	1.15	29.08	0.25	6.35	0.44	11.10
20	31	37/20	1.35	34.16	3.13	79.50	1.03	26.09	1.33	33.83	0.35	8.89	0.63	15.88
	32		1.35	34.16	4.13	104.90	1.03	26.09	1.33	33.83	0.35	8.89	0.63	15.88
	33		1.35	34.16	3.13	79.50	1.06	26.90	1.55	39.40	0.50	12.70	0.75	19.05
	34		1.35	34.16	4.13	104.90	1.06	26.90	1.55	39.40	0.50	12.70	0.75	19.05
	35*		1.35	34.16	3.88	98.55	1.16	29.36	1.77	44.96	0.63	15.88	0.94	23.80
	36*		1.35	34.16	4.88	123.95	1.16	29.36	1.77	44.96	0.63	15.88	0.94	23.80
	37*		1.35	34.16	3.88	98.55	1.38	34.93	2.11	53.67	0.88	22.23	1.25	31.75
	38*		1.35	34.16	4.88	123.95	1.38	34.93	2.11	53.67	0.88	22.23	1.25	31.75
	124		1.35	34.16	3.13	79.50	1.03	26.09	1.15	29.08	0.25	6.35	0.44	11.10
	125		1.35	34.16	4.13	104.90	1.03	26.09	1.15	29.08	0.25	6.35	0.44	11.10
	140		1.35	34.16	3.13	79.50	1.16	29.36	1.77	44.96	0.63	15.88	0.90	22.96
	141		1.35	34.16	4.13	104.90	1.16	29.36	1.77	44.96	0.63	15.88	0.90	22.96
	22		39	22	1.47	37.29	3.13	79.50	1.03	26.09	1.33	33.83	0.35	8.89
40		1.47	37.29		4.13	104.90	1.03	26.09	1.33	33.83	0.35	8.89	0.63	15.88
41		1.47	37.29		3.13	79.50	1.06	26.90	1.55	39.40	0.50	12.70	0.75	19.05
42		1.47	37.29		4.13	104.90	1.06	26.90	1.55	39.40	0.50	12.70	0.75	19.05
43		1.47	37.29		3.13	79.50	1.16	29.36	1.77	44.96	0.63	15.88	0.94	23.80
44		1.47	37.29		4.13	104.90	1.16	29.36	1.77	44.96	0.63	15.88	0.94	23.80
45*		1.47	37.29		3.88	98.55	1.38	34.93	2.11	53.67	0.88	22.23	1.25	31.75
46*		1.47	37.29		4.88	123.95	1.38	34.93	2.11	53.67	0.88	22.23	1.25	31.75
126		1.47	37.29		3.13	79.50	1.03	26.09	0.96	24.31	0.13	3.18	0.31	7.92
127		1.47	37.29		4.13	104.90	1.03	26.09	0.96	24.31	0.13	3.18	0.31	7.92
128		1.47	37.29		3.13	79.50	1.03	26.09	1.15	29.08	0.25	6.35	0.44	11.10
129		1.47	37.29		4.13	104.90	1.03	26.09	1.15	29.08	0.25	6.35	0.44	11.10
142		1.47	37.29		3.13	79.50	1.38	34.93	2.11	53.67	0.88	22.23	1.03	26.14
143		1.47	37.29		4.13	104.90	1.38	34.93	2.11	53.67	0.88	22.23	1.03	26.14
24	47	24	1.59	40.46	3.13	79.50	1.06	26.90	1.55	39.40	0.50	12.70	0.75	19.05
	48		1.59	40.46	4.13	104.90	1.06	26.90	1.55	39.40	0.50	12.70	0.75	19.05
	49		1.59	40.46	3.13	79.50	1.16	29.36	1.77	44.96	0.63	15.88	0.81	20.62
	50		1.59	40.46	4.13	104.90	1.16	29.36	1.77	44.96	0.63	15.88	0.81	20.62
	51		1.59	40.46	3.13	79.50	1.16	29.36	1.77	44.96	0.63	15.88	0.94	23.80
	52		1.59	40.46	4.13	104.90	1.16	29.36	1.77	44.96	0.63	15.88	0.94	23.80
	53*		1.59	40.46	3.88	98.55	1.38	34.93	2.11	53.67	0.88	22.23	1.25	31.75
	54*		1.59	40.46	4.88	123.95	1.38	34.93	2.11	53.67	0.88	22.23	1.25	31.75
	130		1.59	40.46	3.13	79.50	1.03	26.09	1.33	33.83	0.35	8.89	0.63	15.88
	131		1.59	40.46	4.13	104.90	1.03	26.09	1.33	33.83	0.35	8.89	0.63	15.88
	144		1.59	40.46	3.13	79.50	1.38	34.93	2.11	53.67	0.88	22.23	1.14	29.06
	145		1.59	40.46	4.13	104.90	1.38	34.93	2.11	53.67	0.88	22.23	1.14	29.06
	28		55	28	1.97	50.01	3.13	79.50	1.06	26.90	1.55	39.40	0.50	12.70
56		1.97	50.01		4.13	104.90	1.06	26.90	1.55	39.40	0.50	12.70	0.75	19.05
57		1.97	50.01		3.13	79.50	1.16	29.36	1.77	44.96	0.63	15.88	0.94	23.80
58		1.97	50.01		4.13	104.90	1.16	29.36	1.77	44.96	0.63	15.88	0.94	23.80

(*Denotes Style-2
Table continued

STRAIGHT, SPIN COUPLING

26482 Series II; 5015 (MS345X); 83723 Series III

MIL PART NUMBER DESIGNATOR		CONNECTOR SHELL SIZE	TABLE-A											
SHELL SIZE	DASH NO		A DIA. (MAX)		B (MAX)		C (REF) L MAX		G (MAX) L MAX		CABLE RANGE			
			INCH	MM	INCH	MM	INCH	MM	INCH	MM	MIN WIRE		MAX WIRE	
										INCH	MM	INCH	MM	
28, cont.	59	28	1.97	50.01	3.13	79.50	1.38	34.93	2.11	53.67	0.88	22.23	1.25	31.75
	60		1.97	50.01	4.13	104.90	1.38	34.93	2.11	53.67	0.88	22.23	1.25	31.75
	61		1.97	50.01	3.13	79.50	1.50	38.10	23.63	600.20	1.00	25.40	1.38	34.93
	62		1.97	50.01	4.13	104.90	1.50	38.10	2.36	60.02	1.00	25.40	1.38	34.93
32	63	32	2.22	56.36	3.13	79.50	1.16	29.36	1.77	44.96	0.63	15.88	0.94	23.80
	64		2.22	56.36	4.13	104.90	1.16	29.36	1.77	44.96	0.63	15.88	0.94	23.80
	65		2.22	56.36	3.13	79.50	1.38	34.93	2.11	53.67	0.88	22.23	1.25	31.75
	66		2.22	56.36	4.13	104.90	1.38	34.93	2.11	53.67	0.88	22.23	1.25	31.75
	67		2.22	56.36	3.13	79.50	1.50	38.10	2.36	60.02	1.00	25.40	1.38	34.93
	68		2.22	56.36	4.13	104.90	1.50	38.10	2.36	60.02	1.00	25.40	1.38	34.93
	69		2.22	56.36	3.13	79.50	1.78	45.24	2.77	70.36	1.25	31.75	1.63	41.28
	70		2.22	56.36	4.13	104.90	1.78	45.24	2.77	70.36	1.25	31.75	1.63	41.28
36	71	36	2.47	62.71	4.13	104.90	1.38	34.93	2.11	53.67	0.88	22.23	1.25	31.75
	72		2.47	62.71	5.13	130.30	1.38	34.93	2.11	53.67	0.88	22.23	1.25	31.75
	73		2.47	62.71	4.13	104.90	1.50	38.10	2.36	60.02	1.00	25.40	1.38	34.93
	74		2.47	62.71	5.13	130.30	1.50	38.10	2.36	60.02	1.00	25.40	1.38	34.93
	75		2.47	62.71	4.13	104.90	1.78	45.24	2.77	70.36	1.25	31.75	1.63	41.28
	76		2.47	62.71	5.13	130.30	1.78	45.24	2.77	70.36	1.25	31.75	1.63	41.28
	77*		2.47	62.71	5.01	127.25	1.83	46.48	3.02	76.71	1.44	36.50	1.88	47.63
	78*		2.47	62.71	6.01	152.65	1.83	46.48	3.02	76.71	1.44	36.50	1.88	47.63
	132		2.47	62.71	4.13	104.90	1.06	26.90	1.55	39.40	0.50	12.70	0.75	19.05
	133		2.47	62.71	5.13	130.30	1.06	26.90	1.55	39.40	0.50	12.70	0.75	19.05
	146		2.47	62.71	4.13	104.90	1.83	46.48	3.02	76.71	1.44	36.50	1.84	46.74
	147		2.47	62.71	5.13	130.30	1.83	46.48	3.02	76.71	1.44	36.50	1.84	46.74
	148		2.47	62.71	4.13	104.90	1.16	29.36	1.77	44.96	0.63	15.88	0.94	23.80
149	2.47	62.71	5.13	130.30	1.16	29.36	1.77	44.96	0.63	15.88	0.94	23.80		
40	79	40	2.72	69.06	4.13	104.90	1.38	34.93	2.11	53.67	0.88	22.23	1.25	31.75
	80		2.72	69.06	5.13	130.30	1.38	34.93	2.11	53.67	0.88	22.23	1.25	31.75
	81		2.72	69.06	4.13	104.90	1.50	38.10	2.36	60.02	1.00	25.40	1.38	34.93
	82		2.72	69.06	5.13	130.30	1.50	38.10	2.36	60.02	1.00	25.40	1.38	34.93
	83		2.72	69.06	4.13	104.90	1.78	45.24	2.77	70.36	1.25	31.75	1.63	41.28
	84		2.72	69.06	5.13	130.30	1.78	45.24	2.77	70.36	1.25	31.75	1.63	41.28
	85		2.72	69.06	4.13	104.90	1.83	46.48	3.02	76.71	1.44	36.50	1.88	47.63
	86		2.72	69.06	5.13	130.30	1.83	46.48	3.02	76.71	1.44	36.50	1.88	47.63
	134		2.72	69.06	4.13	104.90	1.06	26.90	1.55	39.40	0.50	12.70	0.75	19.05
	135		2.72	69.06	5.13	130.30	1.06	26.90	1.55	39.40	0.50	12.70	0.75	19.05
	156		2.72	69.06	4.13	104.90	1.16	29.36	1.77	44.96	0.63	15.88	0.94	23.80
	157		2.72	69.06	5.13	130.30	1.16	29.36	1.77	44.96	0.63	15.88	0.94	23.80
44	87	44	2.97	75.41	4.13	104.90	1.38	34.93	2.11	53.67	0.88	22.23	1.25	31.75
	88		2.97	75.41	5.13	130.30	1.38	34.93	2.11	53.67	0.88	22.23	1.25	31.75
	89		2.97	75.41	4.13	104.90	1.50	38.10	2.36	60.02	1.00	25.40	1.38	34.93
	90		2.97	75.41	5.13	130.30	1.50	38.10	2.36	60.02	1.00	25.40	1.38	34.93
	91		2.97	75.41	4.13	104.90	1.78	45.24	2.77	70.36	1.25	31.75	1.63	41.28
	92		2.97	75.41	5.13	130.30	1.78	45.24	2.77	70.36	1.25	31.75	1.63	41.28
	93		2.97	75.41	4.13	104.90	1.83	46.48	3.02	76.71	1.44	36.50	1.88	47.63
	94		2.97	75.41	5.13	130.30	1.83	46.48	3.02	76.71	1.44	36.50	1.88	47.63
	154		2.97	75.41	4.13	104.90	1.16	29.36	1.77	44.96	0.63	15.88	0.94	23.80
155	2.97	75.41	5.13	130.30	1.16	29.36	1.77	44.96	0.63	15.88	0.94	23.80		
48	95	48	3.22	81.76	4.13	104.90	1.38	34.93	2.11	53.67	0.88	22.23	1.25	31.75
	96		3.22	81.76	5.13	130.30	1.38	34.93	2.11	53.67	0.88	22.23	1.25	31.75
	97		3.22	81.76	4.13	104.90	1.50	38.10	2.36	60.02	1.00	25.40	1.38	34.93
	98		3.22	81.76	5.13	130.30	1.50	38.10	2.36	60.02	1.00	25.40	1.38	34.93
	99		3.22	81.76	4.13	104.90	1.78	45.24	2.77	70.36	1.25	31.75	1.63	41.28
	100		3.22	81.76	5.13	130.30	1.78	45.24	2.77	70.36	1.25	31.75	1.63	41.28
	101		3.22	81.76	4.13	104.90	1.83	46.48	3.02	76.71	1.44	36.50	1.88	47.63
	102		3.22	81.76	5.13	130.30	1.83	46.48	3.02	76.71	1.44	36.50	1.88	47.63

NON-ENVIRONMENTAL EMI/RFI

90° & 45°; SPIN COUPLING

26482 Series II; 5015 (MS345X); 83723 Series III

MIL Part Number

M85049	/23	-10	W
Series	Slash Sheet	Dash Number (Table B)	Finish (Table 2, pg. 14)
	23 :45° 24: 90		

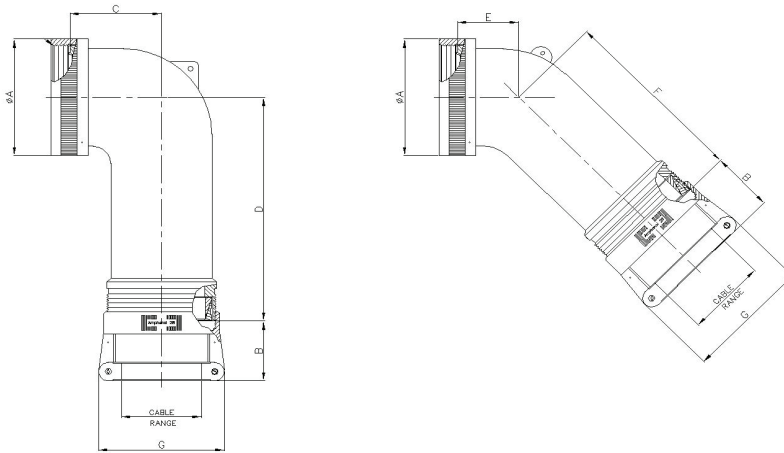

TABLE-B

MIL PART NUMBER DESIGNATOR		CONNECTOR SHELL SIZE	A DIA. (MAX)		B (REF) L MAX		C (MAX)		D (MAX)		E (MAX)		F (MAX)		G (MAX)		CABLE RANGE			
SHELL SIZE	DASH NO		INCH	MM	INCH	MM	INCH	MM	INCH	MM	INCH	MM	INCH	MM	INCH	MM	MIN WIRE		MAX WIRE	
																	INCH	MM	INCH	MM
8	3	8	0.62	15.67	1.03	26.09	0.67	17.02	1.26	32.00	0.63	16.00	1.25	31.75	0.96	24.31	0.13	3.18	0.25	6.35
10	4	10	0.73	18.64	1.03	26.09	0.76	19.30	1.98	50.29	0.69	17.53	1.92	48.77	0.96	24.31	0.13	3.18	0.31	7.92
	49*		0.73	18.64	1.03	26.09	1.52	38.61	2.00	50.80	1.50	38.10	1.98	50.29	1.15	29.08	0.25	6.35	0.44	11.10
	5		0.73	18.64	1.03	26.09	0.76	19.30	1.38	35.05	0.69	17.53	1.31	33.27	1.15	29.08	0.25	6.35	0.38	9.53
12	6	7/12	0.86	21.79	1.03	26.09	0.77	19.56	2.00	50.80	0.75	19.05	1.98	50.29	0.96	24.31	0.13	3.18	0.31	7.92
	71*		0.86	21.79	1.03	26.09	1.81	45.97	2.16	54.86	1.65	41.91	2.18	55.37	1.33	33.83	0.35	8.89	0.63	15.88
	7		0.86	21.79	1.03	26.09	0.77	19.56	2.00	50.80	0.75	19.05	1.98	50.29	1.15	29.08	0.25	6.35	0.44	11.10
	8		0.86	21.79	1.03	26.09	0.77	19.56	1.40	35.56	0.75	19.05	1.98	50.29	1.33	33.83	0.35	8.89	0.50	12.70
14	9	12/14	0.98	24.99	1.03	26.09	0.87	22.10	2.07	52.58	0.81	20.57	2.07	52.58	1.15	29.08	0.25	6.35	0.44	11.10
	10		0.98	24.99	1.03	26.09	0.87	22.10	1.72	43.69	0.81	20.57	1.72	43.69	1.33	33.83	0.35	8.89	0.58	14.61
	50*		0.98	24.99	1.06	26.90	1.89	48.01	2.33	59.18	1.84	46.74	2.37	60.20	1.55	39.40	0.50	12.70	0.75	19.05
	74		0.98	24.99	1.03	26.09	0.87	22.10	2.07	52.58	0.81	20.57	2.07	52.58	0.96	24.31	0.13	3.18	0.31	7.92
16	11	19/16	1.11	28.24	1.03	26.09	1.05	26.67	2.16	54.86	0.91	23.11	2.18	55.37	1.15	29.08	0.25	6.35	0.44	11.10
	12		1.11	28.24	1.06	26.90	1.05	26.67	1.81	45.97	0.91	23.11	1.82	46.23	1.55	39.40	0.50	12.70	0.70	17.78
	40		1.11	28.24	1.03	26.09	1.05	26.67	2.16	54.86	0.91	23.11	2.18	55.37	1.33	33.83	0.35	8.89	0.63	15.88
	51*		1.11	28.24	1.16	29.36	2.04	51.82	2.44	61.98	1.94	49.28	2.52	64.01	1.77	44.96	0.63	15.88	0.94	23.80
	75		1.11	28.24	1.03	26.09	1.05	26.67	2.16	54.86	0.91	23.11	2.18	55.37	0.96	24.31	0.13	3.18	0.31	7.92

(*)Denotes Style-2
Table continued

90° & 45°; SPIN COUPLING

26482 Series II; 5015 (MS345X); 83723 Series III

MIL PART NUMBER DESIGNATOR		CONNECTOR SHELL SIZE	TABLE-B														CABLE RANGE			
			A DIA. (MAX)		B (REF) L MAX		C (MAX)		D (MAX)		E (MAX)		F (MAX)		G (MAX)		MIN WIRE		MAX WIRE	
			INCH	MM	INCH	MM	INCH	MM	INCH	MM	INCH	MM	INCH	MM	INCH	MM	INCH	MM	INCH	MM
18	13	27/18	1.22	30.94	1.03	26.09	1.14	28.96	2.33	59.18	1.09	27.69	2.37	60.20	1.33	33.83	0.35	8.89	0.63	15.88
	14		1.22	30.94	1.16	29.36	1.14	28.96	1.98	50.29	1.09	27.69	2.00	50.80	1.77	44.96	0.63	15.88	0.78	19.79
	41		1.22	30.94	1.03	26.09	1.14	28.96	2.33	59.18	1.09	27.69	2.37	60.20	0.96	24.31	0.13	3.18	0.31	7.92
	42		1.22	30.94	1.03	26.09	1.14	28.96	2.33	59.18	1.09	27.69	2.37	60.20	1.15	29.08	0.25	6.35	0.44	11.10
	52		1.22	30.94	1.06	26.90	1.14	28.96	2.33	59.18	1.09	27.69	2.37	60.20	1.55	39.40	0.50	12.70	0.75	19.05
	72*		1.22	30.94	1.16	29.36	2.05	52.07	2.44	61.98	1.94	49.28	2.52	64.01	1.77	44.96	0.63	15.88	0.94	23.80
20	15	37/20	1.35	34.16	1.03	26.09	1.14	28.96	2.33	59.18	1.09	27.69	2.37	60.20	1.33	33.83	0.35	8.89	0.63	15.88
	16		1.35	34.16	1.16	29.36	1.14	28.96	1.98	50.29	1.09	27.69	2.00	50.80	1.77	44.96	0.63	15.88	0.90	22.96
	43		1.35	34.16	1.03	26.09	1.14	28.96	2.33	59.18	1.09	27.69	2.37	60.20	1.15	29.08	0.25	6.35	0.44	11.10
	54		1.35	34.16	1.06	26.90	1.14	28.96	2.33	59.18	1.09	27.69	2.37	60.20	1.55	39.40	0.50	12.70	0.75	19.05
	55		1.35	34.16	1.38	34.93	2.14	54.36	2.61	66.29	2.06	52.32	2.57	65.28	2.11	53.67	0.88	22.23	1.25	31.75
22	17	22	1.47	37.29	1.06	26.90	1.29	32.77	2.44	61.98	1.19	30.23	2.52	64.01	1.55	39.40	0.50	12.70	0.75	19.05
	18		1.47	37.29	1.38	34.93	1.29	32.77	2.09	53.09	1.19	30.23	2.16	54.86	2.11	53.67	0.88	22.23	1.03	26.14
	44		1.47	37.29	1.03	26.09	1.29	32.77	2.44	61.98	1.19	30.23	2.52	64.01	0.96	24.31	0.13	3.18	0.31	7.92
	45		1.47	37.29	1.03	26.09	1.29	32.77	2.44	61.98	1.19	30.23	2.52	64.01	1.15	29.08	0.25	6.35	0.44	11.10
	56		1.47	37.29	1.03	26.09	1.29	32.77	2.44	61.98	1.19	30.23	2.52	64.01	1.33	33.83	0.35	8.89	0.63	15.88
	57		1.47	37.29	1.16	29.36	1.29	32.77	2.44	61.98	1.19	30.23	2.52	64.01	1.77	44.96	0.63	15.88	0.94	23.80
24	58*	24	1.47	37.29	1.38	34.93	2.14	54.36	2.61	66.29	2.06	52.32	2.57	65.28	2.11	53.67	0.88	22.23	1.25	31.75
	19		1.59	40.46	1.06	26.90	1.29	32.77	2.44	61.98	1.19	30.23	2.52	64.01	1.55	39.40	0.50	12.70	0.75	19.05
	20		1.59	40.46	1.38	34.93	1.29	32.77	2.09	53.09	1.19	30.23	2.16	54.86	2.11	53.67	0.88	22.23	1.14	29.06
	46		1.59	40.46	1.03	26.09	1.29	32.77	2.44	61.98	1.19	30.23	2.52	64.01	1.33	33.83	0.35	8.89	0.63	15.88
	59		1.59	40.46	1.16	29.36	1.29	32.77	2.44	61.98	1.19	30.23	2.52	64.01	1.77	44.96	0.63	15.88	0.94	23.80
28	73*	28	1.59	40.46	1.38	34.93	2.15	54.61	2.61	66.29	2.06	52.32	2.57	65.28	2.12	53.75	0.88	22.23	1.25	31.75
	21		1.97	50.01	1.16	29.36	1.39	35.31	2.61	66.29	1.31	33.27	2.57	65.28	1.77	44.96	0.63	15.88	0.94	23.80
	22		1.97	50.01	1.50	38.10	1.39	35.31	2.26	57.40	1.31	33.27	2.22	56.39	2.36	60.02	1.00	25.40	1.38	34.93
	60		1.97	50.01	1.06	26.90	1.39	35.31	2.61	66.29	1.31	33.27	2.57	65.28	1.55	39.40	0.50	12.70	0.75	19.05
	61		1.97	50.01	1.38	34.93	1.39	35.31	2.61	66.29	1.31	33.27	2.57	65.28	2.11	53.67	0.88	22.23	1.25	31.75
32	23	32	2.22	56.36	1.16	29.36	1.74	44.20	2.86	72.64	1.38	35.05	2.67	67.82	1.77	44.96	0.63	15.88	0.94	23.80
	24		2.22	56.36	1.38	34.93	1.74	44.20	2.86	72.64	1.38	35.05	2.67	67.82	2.11	53.67	0.88	22.23	1.25	31.75
	25		2.22	56.36	1.78	45.24	1.74	44.20	2.51	63.75	1.38	35.05	2.32	58.93	2.77	70.36	1.25	31.75	1.63	41.28
	62		2.22	56.36	1.50	38.10	1.74	44.20	2.86	72.64	1.38	35.05	2.67	67.82	2.36	60.02	1.00	25.40	1.38	34.93
36	26	36	2.47	62.71	1.16	29.36	1.94	49.28	2.83	71.88	1.41	35.81	2.76	70.10	1.77	44.96	0.63	15.88	0.94	23.80
	27		2.47	62.71	1.50	38.10	1.94	49.28	2.83	71.88	1.41	35.81	2.76	70.10	2.36	60.02	1.00	25.40	1.38	34.93
	28		2.47	62.71	1.83	46.48	1.94	49.28	2.48	62.99	1.41	35.81	2.41	61.21	3.02	76.71	1.44	36.50	1.84	46.74
	47		2.47	62.71	1.06	26.90	1.94	49.28	2.83	71.88	1.41	35.81	2.76	70.10	1.55	39.40	0.50	12.70	0.75	19.05
	63		2.47	62.71	1.38	34.93	1.94	49.28	2.83	71.88	1.41	35.81	2.76	70.10	2.11	53.67	0.88	22.23	1.25	31.75
	64		2.47	62.71	1.78	45.24	1.94	49.28	2.83	71.88	1.41	35.81	2.76	70.10	2.77	70.36	1.25	31.75	1.63	41.28
40	29	40	2.72	69.06	1.16	29.36	2.69	68.33	2.83	71.88	2.16	54.86	2.76	70.10	1.77	44.96	0.63	15.88	0.94	23.80
	30		2.72	69.06	1.50	38.10	2.69	68.33	2.83	71.88	2.16	54.86	2.76	70.10	2.36	60.02	1.00	25.40	1.38	34.93
	31		2.72	69.06	1.83	46.48	2.69	68.33	2.48	62.99	2.16	54.86	2.41	61.21	3.02	76.71	1.44	36.50	1.88	47.63
	48		2.72	69.06	1.06	26.90	1.94	49.28	2.83	71.88	2.16	54.86	2.76	70.10	1.55	39.40	0.50	12.70	0.75	19.05
	65		2.72	69.06	1.38	34.93	2.69	68.33	2.83	71.88	2.16	54.86	2.76	70.10	2.11	53.67	0.88	22.23	1.25	31.75
	66		2.72	69.06	1.78	45.24	2.69	68.33	2.83	71.88	2.16	54.86	2.76	70.10	2.77	70.36	1.25	31.75	1.63	41.28
44	32	44	2.97	75.41	1.16	29.36	2.69	68.33	2.83	71.88	2.16	54.86	2.76	70.10	1.77	44.96	0.63	15.88	0.94	23.80
	33		2.97	75.41	1.50	38.10	2.69	68.33	2.83	71.88	2.16	54.86	2.76	70.10	2.36	60.02	1.00	25.40	1.38	34.93
	34		2.97	75.41	1.83	46.48	2.69	68.33	2.48	62.99	2.16	54.86	2.41	61.21	3.02	76.71	1.44	36.50	1.88	47.63
	67		2.97	75.41	1.38	34.93	2.69	68.33	2.83	71.88	2.16	54.86	2.76	70.10	2.11	53.67	0.88	22.23	1.25	31.75
	68		2.97	75.41	1.78	45.24	2.69	68.33	2.83	71.88	2.16	54.86	2.76	70.10	2.77	70.36	1.25	31.75	1.63	41.28
48	35	48	3.22	81.76	1.16	29.36	2.69	68.33	2.83	71.88	2.16	54.86	2.76	70.10	1.77	44.96	0.63	15.88	0.94	23.80
	36		3.22	81.76	1.50	38.10	2.69	68.33	2.83	71.88	2.16	54.86	2.76	70.10	2.36	60.02	1.00	25.40	1.38	34.93
	37		3.22	81.76	1.83	46.48	2.69	68.33	2.48	62.99	2.16	54.86	2.41	61.21	3.02	76.71	1.44	36.50	1.88	47.63
	69		3.22	81.76	1.38	34.93	2.69	68.33	2.83	71.88	2.16	54.86	2.76	70.10	2.11	53.67	0.88	22.23	1.25	31.75
	70		3.22	81.76	1.78	45.24	2.69	68.33	2.83	71.88	2.16	54.86	2.76	70.10	2.77	70.36	1.25	31.75	1.63	41.28

STRAIGHT; DIRECT COUPLING

38999 Series I & Series II

MIL Part Number

M85049	/36	10	W	03	A
Series	Slash Sheet	Shell Size (Table A)	Finish (Table 2, pg. 14)	Clamp Size (Table A)	Length (Table A) Omit for "STD"
	36 : Straight, Direct Coupling				

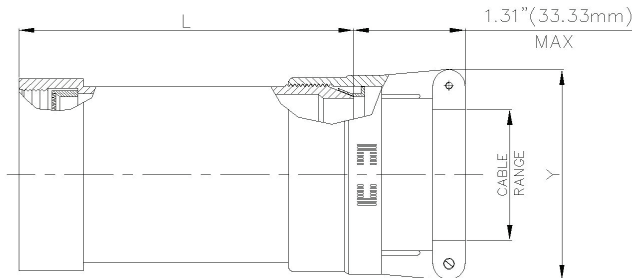

TABLE-A

MIL PART NUMBER DESIGNATOR			CONNECTOR SHELL SIZE SE - II / I	CABLE RANGE				L (MAX)		Y (MAX)	
ACCESSORY SHELL SIZE	CLAMP SIZE	LENGTH CODE		MIN		MAX		INCH	MM	INCH	MM
				INCH	MM	INCH	MM				
08	01	STD.	8 / 9	0.06	1.57	0.13	3.18	1.53	38.86	0.78	19.81
		A						2.53	64.26		
		STD.						1.53	38.86		
	02	STD.		0.13	3.18	0.25	6.35	1.53	38.86	0.97	24.64
		A		2.53	64.26						
		STD.		1.53	38.86						
10	01	STD.	10 / 11	0.06	1.57	0.13	3.18	1.53	38.86	0.78	19.81
		A						2.53	64.26		
		STD.						1.53	38.86		
	02	STD.		0.13	3.18	0.25	6.35	1.53	38.86	0.97	24.64
		A		2.53	64.26						
		STD.		1.53	38.86						
	03	STD.		0.25	6.35	0.38	9.53	1.53	38.86	1.06	26.92
		A		2.53	64.26						
		STD.		1.53	38.86						
12	02	STD.	12 / 13	0.13	3.18	0.25	6.35	1.53	38.86	0.97	24.64
		A						2.53	64.26		
		STD.						1.53	38.86		
	03	STD.		0.25	6.35	0.38	9.53	1.53	38.86	1.06	26.92
		A		2.53	64.26						
		STD.		1.53	38.86						
04	STD.	0.31	7.92	0.50	12.70	1.53	38.86	1.16	29.46		
	A	2.53	64.26								
	STD.	1.53	38.86								
14	02	STD.	14 / 15	0.13	3.18	0.25	6.35	1.53	38.86	0.97	24.64
		A						2.53	64.26		
		B						3.53	89.66		
	03	STD.		0.25	6.35	0.38	9.53	1.53	38.86	1.06	26.92
		A		2.53	64.26						
		B		3.53	89.66						
	04	STD.		0.31	7.92	0.50	12.70	1.53	38.86	1.16	29.46
		A		2.53	64.26						
		B		3.53	89.66						
	05	STD.		0.44	11.10	0.63	15.88	1.53	38.86	1.25	31.75
		A		2.53	64.26						
		B		3.53	89.66						
16	02	STD.	16 / 17	0.13	3.18	0.25	6.35	1.53	38.86	0.97	24.64
		A						2.53	64.26		
		B						3.53	89.66		
	03	STD.		0.25	6.35	0.38	9.53	1.53	38.86	1.06	26.92
		A		2.53	64.26						
		B		3.53	89.66						
	04	STD.		0.31	7.92	0.50	12.70	1.53	38.86	1.16	29.46
		A		2.53	64.26						
		B		3.53	89.66						
	05	STD.		0.44	11.10	0.63	15.88	1.53	38.86	1.25	31.75
		A		2.53	64.26						
		B		3.53	89.66						
	06	STD.		0.56	14.27	0.75	19.05	1.53	38.86	1.38	35.05
		A		2.53	64.26						
		B		3.53	89.66						

Table continued

STRAIGHT; DIRECT COUPLING

38999 Series I & Series II

MIL PART NUMBER DESIGNATOR			CONNECTOR SHELL SIZE SE - II / I	CABLE RANGE				L (MAX)		Y (MAX)	
ACCESSORY SHELL SIZE	CLAMP SIZE	LENGTH CODE		MIN		MAX		INCH	MM	INCH	MM
				INCH	MM	INCH	MM				
18	03	STD.	18 / 19	0.25	6.35	0.38	9.53	1.53	38.86	1.06	26.92
		A						2.53	64.26		
		B						3.53	89.66		
	04	STD.		0.31	7.92	0.50	12.70	1.53	38.86	1.16	29.46
		A						2.53	64.26		
		B						3.53	89.66		
	05	STD.		0.44	11.10	0.63	15.88	1.53	38.86	1.25	31.75
		A						2.53	64.26		
		B						3.53	89.66		
	06	STD.		0.56	14.27	0.75	19.05	1.53	38.86	1.38	35.05
		A						2.53	64.26		
		B						3.53	89.66		
07	STD.	0.69	17.45	0.88	22.23	1.53	38.86	1.50	38.10		
	A					2.53	64.26				
	B					3.53	89.66				
20	03	STD.	20 / 21	0.25	6.35	0.38	9.53	1.53	38.86	1.06	26.92
		A						2.53	64.26		
		B						3.53	89.66		
		C						4.53	115.06		
	04	STD.		0.31	7.92	0.50	12.70	1.53	38.86	1.16	29.46
		A						2.53	64.26		
		B						3.53	89.66		
		C						4.53	115.06		
	05	STD.		0.44	11.10	0.63	15.88	1.53	38.86	1.25	31.75
		A						2.53	64.26		
		B						3.53	89.66		
		C						4.53	115.06		
	06	STD.		0.56	14.27	0.75	19.05	1.53	38.86	1.38	35.05
		A						2.53	64.26		
		B						3.53	89.66		
		C						4.53	115.06		
	07	STD.		0.69	17.45	0.88	22.23	1.53	38.86	1.50	38.10
		A						2.53	64.26		
		B						3.53	89.66		
		C						4.53	115.06		
	08	STD.		0.81	20.62	1.00	25.40	1.53	38.86	1.63	41.40
		A						2.53	64.26		
		B						3.53	89.66		
		C						4.53	115.06		

Table continued

STRAIGHT; DIRECT COUPLING 38999 Series I & Series II

TABLE-A, cont.

MIL PART NUMBER DESIGNATOR			CONNECTOR SHELL SIZE SE - II / I	CABLE RANGE				L (MAX)		Y (MAX)	
ACCESSORY SHELL SIZE	CLAMP SIZE	LENGTH CODE		MIN		MAX		INCH	MM	INCH	MM
				INCH	MM	INCH	MM				
22	03	STD.	22 / 23	0.25	6.35	0.38	9.53	1.53	38.86	1.06	26.92
		A						2.53	64.26		
		B						3.53	89.66		
		C						4.53	115.06		
	04	STD.		0.31	7.92	0.50	12.70	1.53	38.86	1.16	29.46
		A						2.53	64.26		
		B						3.53	89.66		
		C						4.53	115.06		
	05	STD.		0.44	11.10	0.63	15.88	1.53	38.86	1.25	31.75
		A						2.53	64.26		
		B						3.53	89.66		
		C						4.53	115.06		
	06	STD.		0.56	14.27	0.75	19.05	1.53	38.86	1.38	35.05
		A						2.53	64.26		
		B						3.53	89.66		
		C						4.53	115.06		
	07	STD.		0.69	17.45	0.88	22.23	1.53	38.86	1.50	38.10
		A						2.53	64.26		
		B						3.53	89.66		
		C						4.53	115.06		
	08	STD.		0.81	20.62	1.00	25.40	1.53	38.86	1.63	41.40
		A						2.53	64.26		
		B						3.53	89.66		
		C						4.53	115.06		
09	STD.	0.94	23.80	1.13	28.58	1.53	38.86	1.75	44.45		
	A					2.53	64.26				
	B					3.53	89.66				
	C					4.53	115.06				
24	04	STD.	24 / 25	0.31	7.92	0.50	12.70	1.53	38.86	1.16	29.46
		A						2.53	64.26		
		B						3.53	89.66		
		C						4.53	115.06		
	05	STD.		0.44	11.10	0.63	15.88	1.53	38.86	1.25	31.75
		A						2.53	64.26		
		B						3.53	89.66		
		C						4.53	115.06		
	06	STD.		0.56	14.27	0.75	19.05	1.53	38.86	1.38	35.05
		A						2.53	64.26		
		B						3.53	89.66		
		C						4.53	115.06		
	07	STD.		0.69	17.45	0.88	22.23	1.53	38.86	1.50	38.10
		A						2.53	64.26		
		B						3.53	89.66		
		C						4.53	115.06		
	08	STD.		0.81	20.62	1.00	25.40	1.53	38.86	1.63	41.40
		A						2.53	64.26		
		B						3.53	89.66		
		C						4.53	115.06		
	09	STD.		0.94	23.80	1.13	28.58	1.53	38.86	1.75	44.45
		A						2.53	64.26		
		B						3.53	89.66		
		C						4.53	115.06		
10	STD.	1.06	26.97	1.25	31.75	1.53	38.86	1.88	47.75		
	A					2.53	64.26				
	B					3.53	89.66				
	C					4.53	115.06				

STRAIGHT; SPIN COUPLING

38999 Series III, IV

MIL Part Number

M85049	/19	11	W	03	A
Series	Slash Sheet	Shell Size (Table A)	Finish (Table 2, pg. 14)	Clamp Size (Table A)	Length (Table A) Omit for "STD"
	19: Straight				

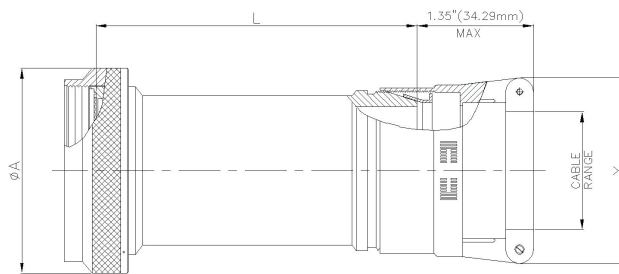

MIL PART NUMBER DESIGNATOR			CONNECTOR SHELL SIZE/ CODE (REF.)	CABLE RANGE				A DIA. (MAX)		L (MAX)		Y (MAX)		
CONNECTOR SHELL SIZE	CLAMP SIZE	LENGTH		MIN		MAX		INCH	MM	INCH	MM	INCH	MM	
				INCH	MM	INCH	MM							
9	01	STD.	09 / A	0.06	1.57	0.13	3.18	0.75	19.05	1.53	38.86	0.80	20.32	
		A								2.53	64.26			
	02	STD.		0.13	3.18	0.25	6.35			1.53	38.86	1.00	25.40	
		A		2.53	64.26									
11	01	STD.	11 / B	0.06	1.57	0.13	3.18	0.85	21.59	1.53	38.86	0.80	20.32	
		A								2.53	64.26			
	02	STD.		0.13	3.18	0.25	6.35			1.53	38.86	1.00	25.40	
		A		2.53	64.26									
	03	STD.		0.25	6.35	0.38	9.53			1.53	38.86	1.10	27.94	
		A		2.53	64.26									
13	02	STD.	13 / C	0.13	3.18	0.25	6.35	1.00	25.40	1.53	38.86	1.00	25.40	
		A								2.53	64.26			
	03	STD.		0.25	6.35	0.38	9.53			1.53	38.86	1.10	27.94	
		A		2.53	64.26									
15	02	STD.	15 / D	0.13	3.18	0.25	6.35	1.10	27.94	1.53	38.86	1.00	25.40	
		A								2.53	64.26			
	B	STD.		0.25	6.35	0.38	9.53			1.53	38.86	1.10	27.94	
		A								2.53	64.26			
	B	STD.		0.31	7.92	0.50	12.70			1.53	38.86	1.20	30.48	
		A								2.53	64.26			
	04	A		STD.	0.44	11.10	0.63			15.88	1.53	38.86	1.25	31.75
				B							2.53	64.26		
STD.		1.53	38.86											
		B	2.53	64.26										

Table continued

STRAIGHT; SPIN COUPLING 38999 Series III, IV

MIL PART NUMBER DESIGNATOR			CONNECTOR SHELL SIZE/CODE (REF.)	CABLE RANGE				A DIA. (MAX)		L (MAX)		Y (MAX)					
CONNECTOR SHELL SIZE	CLAMP SIZE	LENGTH		MIN		MAX		INCH	MM	INCH	MM	INCH	MM				
				INCH	MM	INCH	MM										
17	02	STD.	17 / E	0.13	3.18	0.25	6.35	1.25	31.75	1.53	38.86	1.00	25.40				
		A								2.53	64.26						
		B								3.53	89.66						
	03	STD.		0.25	6.35	0.38	9.53			1.53	38.86	1.10	27.94				
		A								2.53	64.26						
		B								3.53	89.66						
	04	STD.		0.31	7.92	0.50	12.70			1.53	38.86	1.20	30.48				
		A								2.53	64.26						
		B								3.53	89.66						
	05	STD.		0.44	11.10	0.63	15.88			1.53	38.86	1.25	31.75				
		A								2.53	64.26						
		B								3.53	89.66						
	06	STD.		0.56	14.27	0.75	19.05			1.53	38.86	1.40	35.56				
		A								2.53	64.26						
		B								3.53	89.66						
	19	03		STD.	19 / F	0.25	6.35			0.38	9.53	1.40	35.56	1.53	38.86	1.10	27.94
				A										2.53	64.26		
				B										3.53	89.66		
04		STD.	0.31	7.92		0.50	12.70	1.53	38.86	1.20	30.48						
		A						2.53	64.26								
		B						3.53	89.66								
05		STD.	0.44	11.10		0.63	15.88	1.53	38.86	1.25	31.75						
		A						2.53	64.26								
		B						3.53	89.66								
06		STD.	0.56	14.27		0.75	19.05	1.53	38.86	1.40	35.56						
		A						2.53	64.26								
		B						3.53	89.66								
07		STD.	0.69	17.45		0.88	22.23	1.53	38.86	1.50	38.10						
		A						2.53	64.26								
		B						3.53	89.66								
21		03	STD.	21 / G		0.25	6.35	0.38	9.53	1.50	38.10			1.53	38.86	1.10	27.94
			A											2.53	64.26		
			B											3.53	89.66		
	C		4.53		115.06												
	04	STD.	0.31		7.92	0.50	12.70	1.53	38.86			1.20	30.48				
		A						2.53	64.26								
		B						3.53	89.66								
		C						4.53	115.06								
	05	STD.	0.44		11.10	0.63	15.88	1.53	38.86			1.25	31.75				
		A						2.53	64.26								
		B						3.53	89.66								
		C						4.53	115.06								
	06	STD.	0.56		14.27	0.75	19.05	1.53	38.86			1.40	35.56				
		A						2.53	64.26								
		B						3.53	89.66								
		C						4.53	115.06								
	07	STD.	0.69		17.45	0.88	22.23	1.53	38.86			1.50	38.10				
		A						2.53	64.26								
		B						3.53	89.66								
		C						4.53	115.06								
	08	STD.	0.81		20.62	1.00	25.40	1.53	38.86			1.65	41.91				
		A						2.53	64.26								
		B						3.53	89.66								
		C						4.53	115.06								

Table continued

STRAIGHT; SPIN COUPLING 38999 Series III, IV

ML PART NUMBER DESIGNATOR			CONNECTOR SHELL SIZE/CODE (REF.)	CABLE RANGE				A DIA. (MAX)		L (MAX)		Y (MAX)	
CONNECTOR SHELL SIZE	CLAMP SIZE	LENGTH		MIN		MAX		INCH	MM	INCH	MM	INCH	MM
				INCH	MM	INCH	MM						
23	03	STD.	23 / H	0.25	6.35	0.38	9.53	1.65	41.91	1.53	38.86	1.10	27.94
		A								2.53	64.26		
		B								3.53	89.66		
		C								4.53	115.06		
	04	STD.		0.31	7.92	0.50	12.70			1.53	38.86	1.20	30.48
		A								2.53	64.26		
		B								3.53	89.66		
		C								4.53	115.06		
	05	STD.		0.44	11.10	0.63	15.88			1.53	38.86	1.25	31.75
		A								2.53	64.26		
		B								3.53	89.66		
		C								4.53	115.06		
	06	STD.		0.56	14.27	0.75	19.05			1.53	38.86	1.40	35.56
		A								2.53	64.26		
		B								3.53	89.66		
		C								4.53	115.06		
	07	STD.		0.69	17.45	0.88	22.23			1.53	38.86	1.50	38.10
		A								2.53	64.26		
		B								3.53	89.66		
		C								4.53	115.06		
	08	STD.		0.81	20.62	1.00	25.40			1.53	38.86	1.65	41.91
		A								2.53	64.26		
		B								3.53	89.66		
		C								4.53	115.06		
	09	STD.		0.94	23.80	1.13	28.58			1.53	38.86	1.75	44.45
		A								2.53	64.26		
		B								3.53	89.66		
		C								4.53	115.06		
25	04	STD.	25 / J	0.31	7.92	0.50	12.70	1.75	44.45	1.53	38.86	1.20	30.48
		A								2.53	64.26		
		B								3.53	89.66		
		C								4.53	115.06		
	05	STD.		0.44	11.10	0.63	15.88			1.53	38.86	1.25	31.75
		A								2.53	64.26		
		B								3.53	89.66		
		C								4.53	115.06		
	06	STD.		0.56	14.27	0.75	19.05			1.53	38.86	1.40	35.56
		A								2.53	64.26		
		B								3.53	89.66		
		C								4.53	115.06		
	07	STD.		0.69	17.45	0.88	22.23			1.53	38.86	1.50	38.10
		A								2.53	64.26		
		B								3.53	89.66		
		C								4.53	115.06		
	08	STD.		0.81	20.62	1.00	25.40			1.53	38.86	1.65	41.91
		A								2.53	64.26		
		B								3.53	89.66		
		C								4.53	115.06		
	09	STD.		0.94	23.80	1.13	28.58			1.53	38.86	1.75	44.45
		A								2.53	64.26		
		B								3.53	89.66		
		C								4.53	115.06		
	10	STD.		1.06	26.97	1.25	31.75			1.53	38.86	1.90	48.26
		A								2.53	64.26		
		B								3.53	89.66		
		C								4.53	115.06		

STRAIGHT; 90°; SPIN COUPLING; SELF-LOCK W/ SHIELD

26482 Series II; 5015 (MS345X); 83723 Series III

MIL Part Number

M85049	/109	S	10	T	W	03	-6	
Series	Slash Sheet	Coupling	Shell Size (Table A)	Shield Finish	Finish (Table 2, pg. 14)	Entry Size (Table A & B)	Shield Length	D: Drain Hole
	109: Straight 111: 90°	-.:Spin Coupling S:Self-Lock		(Material: Copper) K: Nickel T: Tin			6 inches min. 18 inches max. 1 inch increments 6: 6 inch, 7: 7 inch etc.	

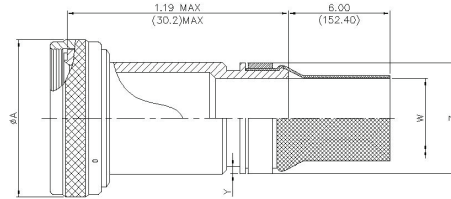
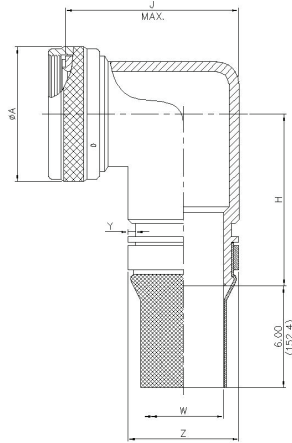

TABLE - B

ENTRY SIZE	W ±0.020	W ±0.508	Y +0.008 -0.000	Y +0.200 -0.000	Z MAX	Z MAX
	INCH	MM	INCH	MM	INCH	MM
01	0.250	6.350	0.044	1.12	0.56	14.22
02	0.312	7.920	0.044	1.12	0.63	16.00
03	0.375	9.530	0.044	1.12	0.69	17.53
04	0.438	11.130	0.044	1.12	0.75	19.05
05	0.500	12.700	0.044	1.12	0.82	20.83
06	0.562	14.270	0.044	1.12	0.89	22.61
07	0.625	15.880	0.044	1.12	0.95	24.13
08	0.688	17.480	0.044	1.12	1.02	25.91
09	0.750	19.050	0.069	1.75	1.07	27.18
10	0.812	20.620	0.069	1.75	1.13	28.70
11	0.875	22.230	0.069	1.75	1.19	30.23
12	0.938	23.830	0.069	1.75	1.26	32.00
13	1.000	25.400	0.069	1.75	1.32	33.53
14	1.125	28.575	0.069	1.75	1.47	37.34
15	1.250	31.750	0.069	1.75	1.60	40.64
16	1.375	34.930	0.069	1.75	1.71	43.43
17	1.500	38.100	0.086	2.18	1.84	46.74
18	1.625	41.280	0.086	2.18	2.00	50.80
19	1.750	44.450	0.086	2.18	2.12	53.85
20	1.875	47.630	0.086	2.18	2.27	57.66
21	2.000	50.800	0.086	2.18	2.44	61.98
22	2.125	53.980	0.086	2.18	2.60	66.04
23	2.250	57.150	0.086	2.18	2.75	69.85
24	2.375	60.325	0.086	2.18	2.90	73.66
25	2.500	63.500	0.086	2.18	3.06	77.72

TABLE - A

PART NUMBER DESIGNATOR			CONNECTOR SHELL SIZE	A DIA.(MAX)		H (MAX)		J (MAX)	
SHELL SIZE-MIL	ALLOWABLE ENTRY SIZE			INCH	MM	INCH	MM	INCH	MM
	MIN	MAX							
08	-	01	8	0.885	22.48	1.73	43.94	1.12	28.45
10	01	03	10	1.010	25.65	1.85	46.99	1.25	31.75
12	01	05	7/12	1.135	28.83	1.87	47.50	1.38	35.05
14	02	06	12/14	1.260	32.00	1.94	49.28	1.44	36.58
16	04	08	19/16	1.385	35.18	2.03	51.56	1.56	39.62
18	05	09	27/18	1.510	38.35	2.20	55.88	1.75	44.45
20	07	11	37/20	1.635	41.53	2.20	55.88	1.75	44.45
22	09	13	22	1.760	44.70	2.31	58.67	2.00	50.80
24	11	14	24	1.885	47.88	2.31	58.67	2.00	50.80
28	14	16	28	2.135	54.23	2.48	62.99	2.25	57.15
32	16	17	32	2.395	60.83	2.73	69.34	2.75	69.85
36	17	19	36	2.635	66.93	2.73	69.34	3.125	79.38
40	19	21	40	2.885	73.28	2.88	73.15	4.125	104.78
44	21	23	44	3.135	79.63	3.00	76.20	4.125	104.78
48	23	25	48	3.385	85.98	3.12	79.25	4.125	104.78

STRAIGHT; 90°; SPIN COUPLING; SELF-LOCK W/ SHIELD

38999 Series I & Series II

MIL Part Number

M85049	/112	S	10	T	W	03	-6	
Series	Slash Sheet	Coupling	Shell Size (Table A)	Shield Finish	Finish (Table 2, pg. 14)	Entry Size (Table A & B)	Shield Length	D
	112: Straight 114: 90°	--Spin Coupling S:Self-Lock		(Material: Copper) K: Nickel T: Tin			6 inches min. 18 inches max. 1 inch increments 6: 6 inch, 7: 7 inch etc.	

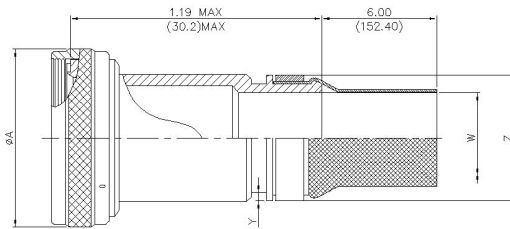
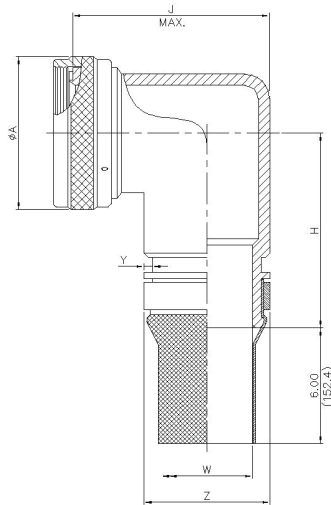

TABLE - A

MIL PART NUMBER DESIGNATOR			CONNECTOR SHELL SIZE SE - II / I	A DIA.(MAX)		H (MAX)		J (MAX)	
ACCESSORY SHELL SIZE	ALLOWABLE ENTRY SIZE			INCH	MM	INCH	MM	INCH	MM
	MIN	MAX							
08	-	01	8/9	0.860	21.84	1.73	43.94	1.07	27.18
10	01	03	10/11	0.980	24.89	1.85	46.99	1.19	30.23
12	01	05	12/13	1.160	29.46	1.87	47.50	1.32	33.53
14	03	07	14/15	1.280	32.51	1.94	49.28	1.44	36.58
16	05	09	16/17	1.410	35.81	2.03	51.56	1.57	39.88
18	06	10	18/19	1.520	38.61	2.20	55.88	1.75	44.45
20	08	12	20/21	1.640	41.66	2.20	55.88	1.75	44.45
22	09	13	22/23	1.770	44.96	2.31	58.67	2.00	50.80
24	10	14	24/25	1.890	48.01	2.31	58.67	2.00	50.80

TABLE - B

ENTRY SIZE	W	W	Y	Y	Z	Z
	±0.020	±0.508	+0.008 -0.000	+0.200 -0.000	MAX	MAX
	INCH	MM	INCH	MM	INCH	MM
01	0.250	6.350	0.044	1.12	0.56	14.22
02	0.312	7.920	0.044	1.12	0.63	16.00
03	0.375	9.530	0.044	1.12	0.69	17.53
04	0.438	11.130	0.044	1.12	0.75	19.05
05	0.500	12.700	0.044	1.12	0.82	20.83
06	0.562	14.270	0.044	1.12	0.89	22.61
07	0.625	15.880	0.044	1.12	0.95	24.13
08	0.688	17.480	0.044	1.12	1.02	25.91
09	0.750	19.050	0.069	1.75	1.07	27.18
10	0.812	20.620	0.069	1.75	1.13	28.70
11	0.875	22.230	0.069	1.75	1.19	30.23
12	0.938	23.830	0.069	1.75	1.26	32.00
13	1.000	25.400	0.069	1.75	1.32	33.53
14	1.125	28.575	0.069	1.75	1.47	37.34

STRAIGHT; 90°; SPIN COUPLING; SELF-LOCK W/ SHIELD

38999 Series III & Series IV

MIL Part Number

M85049	/115	-	11	T	W	03	-6	
Series	Slash Sheet	Coupling	Shell Size (Table A)	Shield Finish	Finish (Table 2, pg. 14)	Entry Size (Table A & B)	Shield Length	D
	115: Straight 117: 90°	--Spin Coupling S:Self-Lock		(Material: Copper) K: Nickel T: Tin			6 inches min. 18 inches max. 1 inch increments 6: 6 inch, 7: 7 inch etc.	

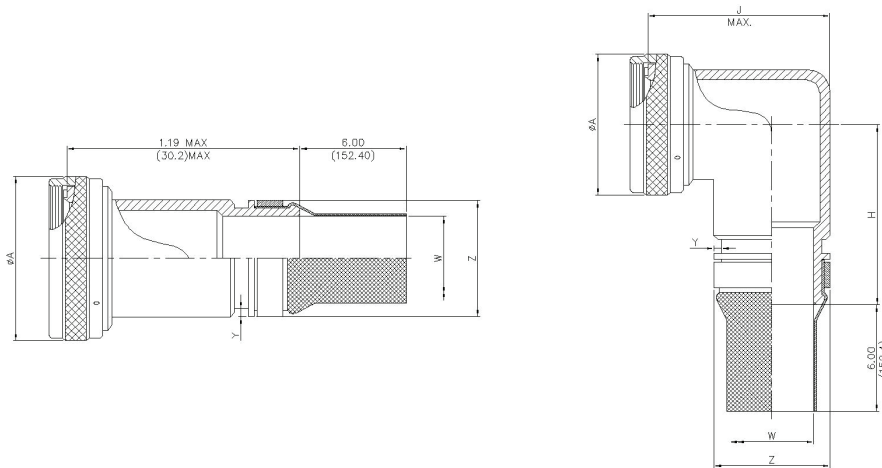

PART NUMBER DESIGNATOR			CONNECTOR SHELL SIZE/ CODE (REF.)	A DIA.(MAX)		H (MAX)		J (MAX)	
SHELL SIZE- MIL	ALLOWABLE ENTRY SIZE			INCH	MM	INCH	MM	INCH	MM
	MIN	MAX							
09	-	01	9 / A	0.860	21.84	1.73	43.94	0.88	22.35
11	01	03	11 / B	0.980	24.89	1.85	46.99	1.00	25.40
13	01	05	13 / C	1.160	29.46	1.87	47.50	1.13	28.70
15	03	07	15 / D	1.280	32.51	1.94	49.28	1.31	33.27
17	05	09	17 / E	1.410	35.81	2.03	51.56	1.50	38.10
19	06	10	19 / F	1.520	38.61	2.20	55.88	1.75	44.45
21	08	12	21 / G	1.640	41.66	2.20	55.88	1.75	44.45
23	09	13	23 / H	1.770	44.96	2.31	58.67	2.00	50.80
25	10	14	25 / J	1.890	48.01	2.31	58.67	2.00	50.80

ENTRY SIZE	W	W	Y	Y	Z	Z
	±0.020	±0.508	+0.008	+0.200	MAX	MAX
	-0.000	-0.000	-0.000	-0.000	INCH	MM
	INCH	MM	INCH	MM	INCH	MM
01	0.250	6.350	0.044	1.12	0.56	14.22
02	0.312	7.920	0.044	1.12	0.63	16.00
03	0.375	9.530	0.044	1.12	0.69	17.53
04	0.438	11.130	0.044	1.12	0.75	19.05
05	0.500	12.700	0.044	1.12	0.82	20.83
06	0.562	14.270	0.044	1.12	0.89	22.61
07	0.625	15.880	0.044	1.12	0.95	24.13
08	0.688	17.480	0.044	1.12	1.02	25.91
09	0.750	19.050	0.069	1.75	1.07	27.18
10	0.812	20.620	0.069	1.75	1.13	28.70
11	0.875	22.230	0.069	1.75	1.19	30.23
12	0.938	23.830	0.069	1.75	1.26	32.00
13	1.000	25.400	0.069	1.75	1.32	33.53
14	1.125	28.575	0.069	1.75	1.47	37.34

STRAIGHT; 90° & 45°; SELF-LOCK/NON SELF-LOCK 26482 Series II; 5015 (MS345X); 83723 Series III

MIL Part Number

M85049	/53	-	10	W
Series	Slash Sheet	Coupling	Dash Number (Table A)	Finish (Table 2, pg. 14)
	53: Straight 54: 45° 55: 90°	-Spin Coupling S: Self-Lock G: Non Self Lock w/grounding Lug (90° Only) T: Self-Lock with grounding lug (only for 90°)		

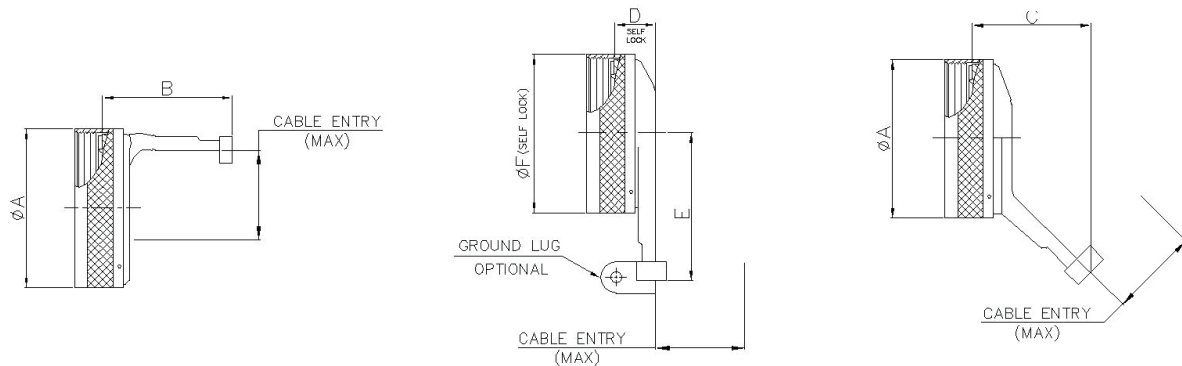

TABLE - A

MIL PART NUMBER DESIGNATOR	CONNECTOR SHELL SIZE	A DIA.(MAX)		B (MAX)		C (MAX)		D (MAX)		E (MAX)		F DIA.(MAX)		WIRING ENTRY MAX	
		INCH	MM	INCH	MM	INCH	MM	INCH	MM	INCH	MM	INCH	MM	INCH	MM
8	8	0.66	16.69	0.95	24.23	1.23	31.29	0.73	18.54	1.22	30.99	0.89	22.48	0.26	6.60
10	10	0.78	19.86	0.95	24.23	1.23	31.29	0.73	18.54	1.29	32.77	1.01	25.65	0.37	9.27
12	07/12/12	0.94	23.80	0.95	24.23	1.23	31.29	0.73	18.54	1.62	41.15	1.14	28.83	0.50	12.73
14	12/14/12	1.05	26.67	1.20	30.58	1.23	31.29	0.73	18.54	1.66	42.16	1.26	32.00	0.58	14.61
16	19/16	1.24	31.47	1.20	30.58	1.23	31.29	0.73	18.54	1.72	43.69	1.39	35.18	0.70	17.78
18	27/18	1.38	35.00	1.20	30.58	1.23	31.29	0.73	18.54	1.72	43.69	1.51	38.35	0.78	19.79
20	37/20	1.50	38.10	1.31	33.27	1.48	37.64	0.75	19.05	1.79	45.47	1.64	41.53	0.90	22.96
22	22	1.63	41.43	1.43	36.32	1.48	37.64	0.75	19.05	1.85	46.99	1.76	44.70	1.03	26.14
24	24	1.75	44.45	1.56	39.62	1.48	37.64	0.75	19.05	1.91	48.51	1.89	47.88	1.14	29.06
28	28	1.97	50.04	1.56	39.62	1.47	37.31	0.75	19.05	2.06	52.32	2.14	54.23	1.38	35.03

STRAIGHT; 90° & 45°; SELF-LOCK/NON SELF-LOCK
38999 Series I & Series II

MIL Part Number

M85049	/56	-	10	W
Series	Slash Sheet	Coupling	Dash Number (Table A)	Finish (Table 2, pg. 14)
	56: Straight 57: 45° 63: 90°	-:Spin Coupling S:Self-Lock G: Non Self Lock w/grounding Lug (/57 and /63 Only)		

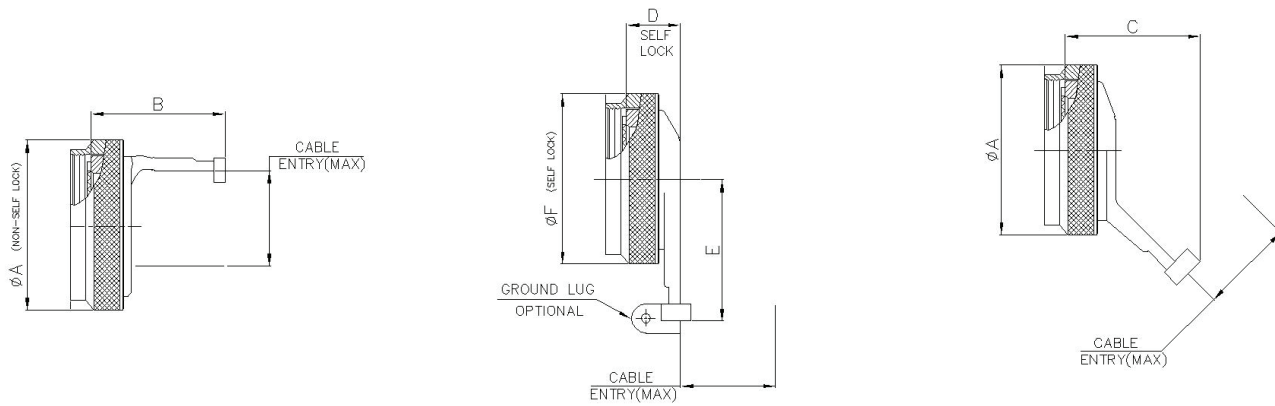

TABLE - A

MIL PART NUMBER DESIGNATOR	CONNECTOR SHELL SIZE SE	A DIA.(MAX)		B (MAX)		C (MAX)		D (MAX)		E (MAX)		F DIA.(MAX)		CABLE ENTRY MAX	
		INCH	MM	INCH	MM	INCH	MM	INCH	MM	INCH	MM	INCH	MM	INCH	MM
DASH NO	- II/I														
8	8 / 9	0.66	16.69	0.95	24.23	1.23	31.29	0.73	18.54	1.22	30.99	0.89	22.48	0.26	6.60
10	10 / 11	0.78	19.86	0.95	24.23	1.23	31.29	0.73	18.54	1.29	32.77	1.01	25.65	0.37	9.27
12	12 / 13	0.94	23.80	0.95	24.23	1.23	31.29	0.73	18.54	1.62	41.15	1.14	28.83	0.50	12.73
14	14 / 15	1.05	26.67	1.20	30.58	1.23	31.29	0.73	18.54	1.66	42.16	1.26	32.00	0.58	14.61
16	16 / 17	1.24	31.47	1.20	30.58	1.23	31.29	0.73	18.54	1.72	43.69	1.39	35.18	0.70	17.78
18	18 / 19	1.38	35.00	1.20	30.58	1.23	31.29	0.73	18.54	1.72	43.69	1.51	38.35	0.78	19.79
20	20 / 21	1.50	38.10	1.31	33.27	1.48	37.64	0.75	19.05	1.79	45.47	1.64	41.53	0.90	22.96
22	22 / 23	1.63	41.43	1.43	36.32	1.48	37.64	0.75	19.05	1.85	46.99	1.76	44.70	1.03	26.14
24	24 / 25	1.75	44.45	1.56	39.62	1.48	37.64	0.75	19.05	1.91	48.51	1.89	47.88	1.14	29.06

90° & 45°; SELF-LOCK/NON SELF-LOCK 38999 Series III & Series IV

MIL Part Number

M85049	/16	-	11	W
Series	Slash Sheet	Coupling	Dash Number (Table A)	Finish (Table 2, pg. 14)
	15: 45° 16: 90°	-: Spin Coupling S: Self-Lock G: Non Self Lock w/grounding Lug (/57 and /63 Only)		

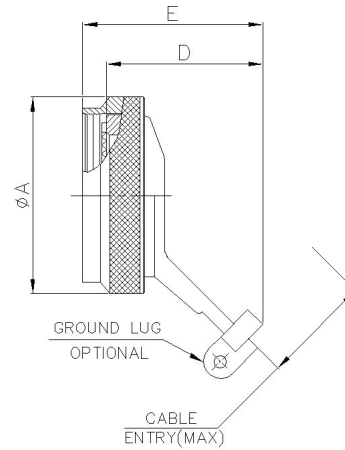
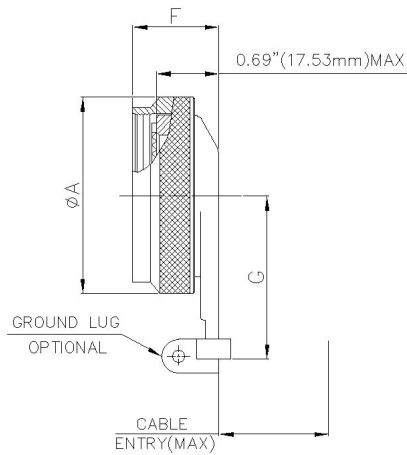

TABLE - A

MIL PART NUMBER DESIGNATOR	CONNECTOR SHELL SIZE/ CODE (REF.)	A DIA.(MAX)		D (MAX)		E (MAX)		F (MAX)		G (MAX)		CABLE ENTRY MAX	
		INCH	MM	INCH	MM	INCH	MM	INCH	MM	INCH	MM	INCH	MM
9	9 / A	0.86	21.79	1.03	26.16	1.43	36.32	0.99	25.15	1.22	30.99	0.26	6.71
11	11 / B	0.98	24.99	1.03	26.16	1.43	36.32	0.99	25.15	1.29	32.77	0.39	9.96
13	13 / C	1.16	29.39	1.03	26.16	1.43	36.32	0.99	25.15	1.62	41.15	0.51	12.85
15	15 / D	1.28	32.49	1.09	27.69	1.93	49.02	0.99	25.15	1.66	42.16	0.63	16.03
17	17 / E	1.41	35.71	1.11	28.19	1.93	49.02	0.99	25.15	1.72	43.69	0.76	19.20
19	19 / F	1.52	38.51	1.21	30.73	2.03	51.56	0.99	25.15	1.72	43.69	0.85	21.46
21	21 / G	1.64	41.71	1.26	32.00	2.09	53.09	0.99	25.15	1.79	45.47	0.97	24.64
23	23 / H	1.77	44.91	1.30	33.02	2.09	53.09	0.99	25.15	1.85	46.99	1.10	27.81
25	25 / J	1.89	47.98	1.34	34.04	2.24	56.90	0.99	25.15	1.91	48.51	1.22	30.99

SHRINK BOOT ADAPTER

STRAIGHT; SPIN COUPLING

26482 Series II; 5015 (MS345X); 83723 Series III

MIL Part Number

M85049	/60-1	W	10
Series	Slash Sheet	Finish (Table 2, pg. 14)	Dash Number (Table A)
	60-1: Straight		

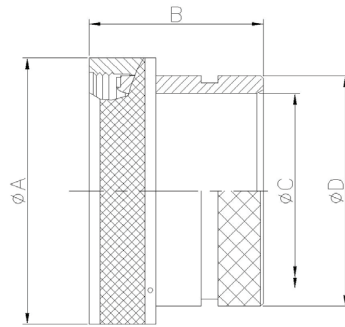

TABLE-A

MIL PART NUMBER DESIGNATOR	CONNECTOR SHELL SIZE	A DIA. (MAX)		B (MAX)		C DIA. (MIN)		D DIA. (MAX)	
		INCH	MM	INCH	MM	INCH	MM	INCH	MM
DASH NO									
8	8	0.62	15.67	1.19	30.15	0.25	6.35	0.53	13.54
10	10	0.73	18.64	1.19	30.15	0.36	9.02	0.61	15.37
12	7/12	0.86	21.79	1.19	30.15	0.49	12.47	0.77	19.66
14	12/14	0.98	24.99	1.19	30.15	0.57	14.35	0.84	21.29
16	19/16	1.11	28.24	1.19	30.15	0.69	17.53	0.96	24.46
18	27/18	1.22	30.94	1.19	30.15	0.77	19.53	1.04	26.47
20	37/20	1.35	34.16	1.19	30.15	0.89	22.71	1.22	30.91
22	22	1.47	37.29	1.19	30.15	1.02	25.88	1.36	34.42
24	24	1.59	40.46	1.19	30.15	1.13	28.80	1.44	36.65
28	28	1.97	50.01	1.51	38.38	1.37	34.77	1.71	43.41
32	32	2.22	56.36	1.51	38.38	1.62	41.02	1.92	48.74
36	36	2.47	62.71	1.51	38.38	1.83	46.48	2.17	55.09
40	40	2.72	69.06	1.51	38.38	2.05	51.94	2.40	61.01
44	44	2.97	75.41	1.51	38.38	2.30	58.42	2.66	67.49
48	48	3.22	81.76	1.51	38.38	2.55	64.77	2.91	73.84

STRAIGHT; SPIN COUPLING

38999 Series I & Series II

MIL Part Number

M85049	/62	10	W	D
Series	Slash Sheet	Dash Number (Table A)	Finish (Table 2, pg. 14)	D: Drain Hole
	62: Straight			

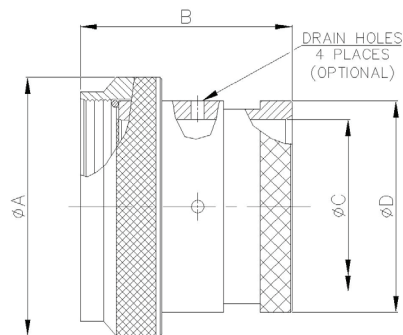

TABLE-A

MIL PART NUMBER DESIGNATOR	CONNECTOR SHELL SIZE	A DIA. (MAX)		B (MAX)		C DIA. (MIN)		D DIA. (MAX)	
		INCH	MM	INCH	MM	INCH	MM	INCH	MM
DASH NO									
8	8	0.62	15.67	1.19	30.15	0.25	6.35	0.53	13.54
10	10	0.73	18.64	1.19	30.15	0.36	9.02	0.61	15.37
12	7/12	0.86	21.79	1.19	30.15	0.49	12.47	0.77	19.66
14	12/14	0.98	24.99	1.19	30.15	0.57	14.35	0.84	21.29
16	19/16	1.11	28.24	1.19	30.15	0.69	17.53	0.96	24.46
18	27/18	1.22	30.94	1.19	30.15	0.77	19.53	1.04	26.47
20	37/20	1.35	34.16	1.19	30.15	0.89	22.71	1.22	30.91
22	22	1.47	37.29	1.19	30.15	1.02	25.88	1.36	34.42
24	24	1.59	40.46	1.19	30.15	1.13	28.80	1.44	36.65
28	28	1.97	50.01	1.51	38.38	1.37	34.77	1.71	43.41
32	32	2.22	56.36	1.51	38.38	1.62	41.02	1.92	48.74
36	36	2.47	62.71	1.51	38.38	1.83	46.48	2.17	55.09
40	40	2.72	69.06	1.51	38.38	2.05	51.94	2.40	61.01
44	44	2.97	75.41	1.51	38.38	2.30	58.42	2.66	67.49
48	48	3.22	81.76	1.51	38.38	2.55	64.77	2.91	73.84

SHRINK BOOT ADAPTER

STRAIGHT; SPIN COUPLING

38999 Series III, IV

MIL Part Number

M85049	/69	11	W	D
Series	Slash Sheet	Shell Size (Table A)	Finish (Table 2, pg. 14)	D: Drain Hole
	69: Straight			

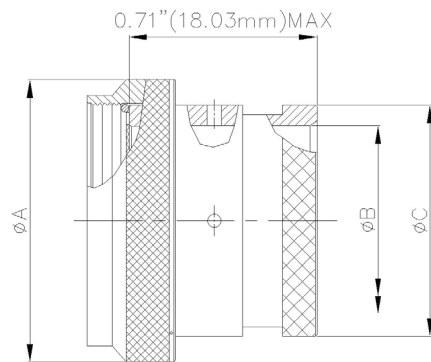

TABLE-A							
MIL PART NUMBER DESIGNATOR	CONNECTOR SHELL SIZE/ CODE (REF.)	A DIA. (MAX)		B DIA. (MIN)		C DIA. (MAX)	
CONNECTOR SHELL SIZE		INCH	MM	INCH	MM	INCH	MM
9	09 / A	0.75	19.05	0.25	6.35	0.53	13.54
11	11 / B	0.85	21.59	0.38	9.53	0.61	15.37
13	13 / C	1.00	25.40	0.50	12.70	0.77	19.66
15	15 / D	1.15	29.21	0.63	15.88	0.84	21.29
17	17 / E	1.25	31.75	0.75	19.05	0.94	23.77
19	19 / F	1.40	35.56	0.81	20.62	1.04	26.47
21	21 / G	1.55	39.37	0.94	23.80	1.22	30.91
23	23 / H	1.65	41.91	1.06	26.97	1.36	34.42
25	25 / J	1.85	46.99	1.19	30.18	1.44	36.65

STRAIN RELIEF CLAMP

STRAIGHT; 90° & 45°; SELF-LOCK/NON SELF-LOCK
26482 Series II; 5015 (MS345X); 83723 Series III

MIL Part Number

M85049	/52	-	10	W
Series	Slash Sheet	Coupling	Dash Number (Table A)	Finish (Table 2, pg. 14)
	43: 45° 51: 90° 52: Straight	S: Self Lock (/51 and /52 Only) -: Non Self Lock (/43 Only) -1: Non Self-Lock (/51 and /52 Only)		

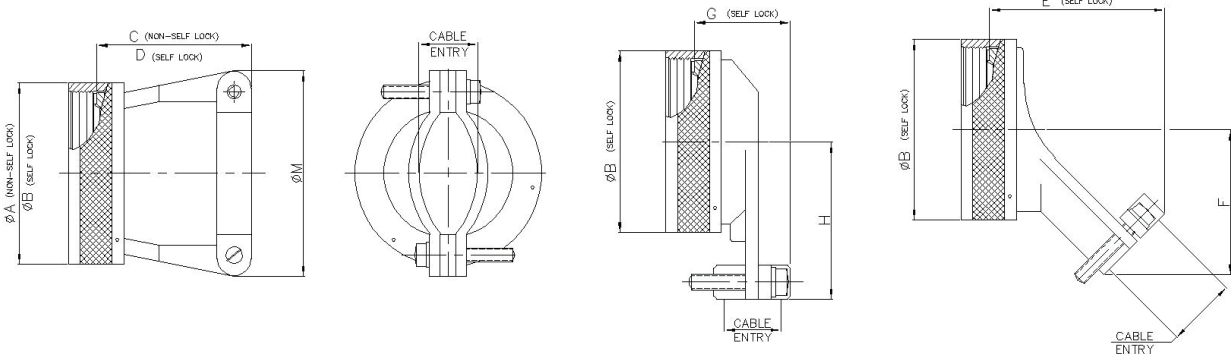

MIL PART NUMBER DESIGNATOR	CONNECTOR SHELL SIZE	A DIA.(MAX)		B DIA.(MAX)		C (MAX)		D (MAX)		E (MAX)		F (MAX)	
		INCH	MM	INCH	MM	INCH	MM	INCH	MM	INCH	MM	INCH	MM
8	8	0.62	15.67	0.89	22.48	0.63	16.00	0.73	18.54	1.32	33.53	0.77	19.61
10	10	0.73	18.64	1.01	25.65	0.74	18.80	0.85	21.59	1.36	34.65	0.80	20.40
12	7/12	0.86	21.79	1.14	28.83	0.86	21.84	0.98	24.89	1.44	36.53	0.87	22.00
14	12/14	0.98	24.99	1.26	32.00	0.86	21.84	0.98	24.89	1.48	37.59	0.93	23.57
16	19/16	1.11	28.24	1.39	35.18	0.99	25.15	1.10	27.94	1.59	40.28	0.99	25.17
18	27/18	1.22	30.94	1.51	38.35	1.24	31.50	1.35	34.29	1.70	43.28	1.11	28.19
20	37/20	1.35	34.16	1.64	41.53	1.36	34.54	1.48	37.59	1.75	44.40	1.17	29.77
22	22	1.47	37.29	1.76	44.70	1.49	37.85	1.60	40.64	1.79	45.52	1.24	31.37
24	24	1.59	40.46	1.89	47.88	1.61	40.89	1.73	43.94	1.84	46.63	1.30	32.94
28	28	1.97	50.01	2.14	54.23	1.76	44.70	1.88	47.75	1.96	49.81	1.54	39.19
32	32	2.22	56.36	2.40	60.83	1.95	49.53	2.13	54.10	2.05	52.04	1.67	42.37
36	36	2.47	62.71	2.64	66.93	2.33	59.18	2.44	61.98	2.09	53.16	1.79	45.54
40	40	2.72	69.06	2.89	73.28	2.51	63.75	2.63	66.80	2.09	53.19	1.92	48.72
44	44	2.97	75.41	3.14	79.63	2.89	73.41	3.00	76.20	2.36	59.94	2.13	54.15
48	48	3.22	81.76	3.39	85.98	3.26	82.80	3.40	86.36	2.45	62.18	2.26	57.33

STRAIN RELIEF CLAMP

STRAIGHT; 90° & 45°; SELF-LOCK/NON SELF-LOCK
26482 Series II; 5015 (MS345X); 83723 Series III

TABLE - A											
MIL PART NUMBER DESIGNATOR	CONNECTOR SHELL SIZE	G (MAX)		H (MAX)		M (MAX)		CABLE ENTRY			
		INCH	MM	INCH	MM	INCH	MM	MIN		MAX	
DASH NO								INCH	MM	INCH	MM
08	8	0.93	23.62	0.75	18.95	0.78	19.86	0.13	3.18	0.20	5.18
10	10	1.02	25.91	0.81	20.45	0.86	21.89	0.19	4.75	0.29	7.26
12	7/12	1.21	30.73	0.87	22.02	1.00	25.48	0.29	7.39	0.42	10.57
14	12/14	1.27	32.26	0.93	23.62	1.06	26.95	0.35	8.92	0.48	12.09
16	19/16	1.42	36.07	0.99	25.25	1.33	33.88	0.50	12.73	0.63	15.90
18	27/18	1.53	38.86	1.17	29.74	1.47	37.24	0.52	13.16	0.71	17.93
20	37/20	1.65	41.91	1.23	31.34	1.57	39.93	0.58	14.76	0.83	21.11
22	22	1.78	45.21	1.30	32.92	1.69	42.88	0.64	16.36	0.96	24.28
24	24	1.90	48.26	1.36	34.49	1.79	45.47	0.71	17.93	1.08	27.46
28	28	2.20	55.88	1.57	39.93	2.04	51.69	0.75	19.05	1.19	30.15
32	32	2.27	57.66	1.80	45.64	2.39	60.60	0.88	22.23	1.25	31.75
36	36	2.39	60.71	1.92	48.82	2.50	63.40	0.94	23.83	1.38	34.93
40	40	2.52	64.01	2.05	51.99	2.57	65.18	0.94	23.83	1.50	38.10
44	44	2.77	70.36	2.30	58.32	2.86	72.64	1.19	30.18	1.75	44.45
48	48	2.89	73.41	2.42	61.49	3.34	84.94	1.31	33.32	1.88	47.63

STRAIN RELIEF CLAMP

STRAIGHT

MIL Part Number

M85049	/41	10	W
Series	Slash Sheet	Dash Number (Table A)	Finish (Table 2, pg. 14)
	41: Straight 42: Straight		

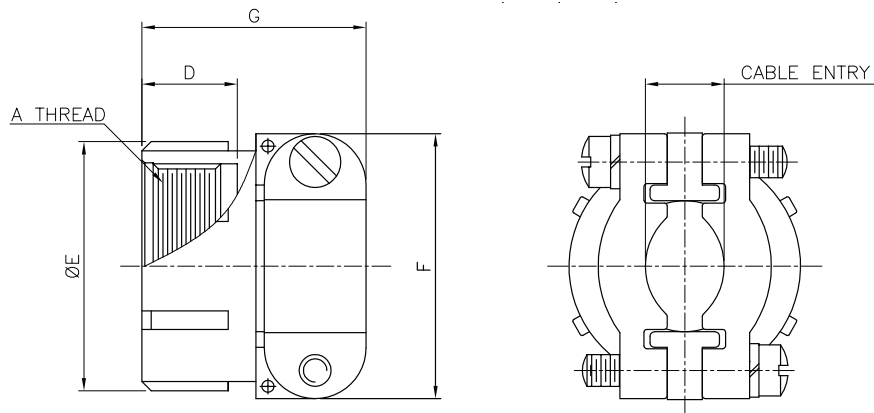

MIL PART NUMBER DESIGNATOR	CONNECTOR SHELL SIZE/ CODE (REF.)	A Thread Class 2B	CABLE ENTRY (MAX)		D (MAX)		E (MAX)		F (MAX)		G (MAX)	
			INCH	MM	±.016	±.40	±.031	±.787	±.031	±.787	±.031	±.787
					INCH	MM	INCH	MM	INCH	MM	INCH	MM
3A	8S, 10S	0.500-28 UNEF	0.250	6.4	0.406	10.3	688	17.5	0.812	20.6	0.812	20.6
4A	10SL, 12S, 12	0.625-24 UNEF	0.312	7.9	0.406	10.3	812	20.6	0.875	22.2	0.812	20.6
6A	14S, 14	0.750-20 UNEF	0.438	11.1	0.406	10.3	969	24.6	1.062	27.0	0.875	22.2
8A	16, 16S	0.875-20 UNEF	0.562	14.3	0.406	10.3	1.094	27.8	1.156	29.4	0.938	23.8
10A	18	1.000-20 UNEF	0.625	15.9	0.406	10.3	1.188	30.2	1.250	31.8	0.938	23.8
12A	20, 22	1.188-18 UNEF	0.750	19.1	0.406	10.3	1.375	34.9	1.469	37.3	0.938	23.8
16A	24, 28	1.438-18 UNEF	0.938	23.8	0.406	10.3	1.656	42.1	1.688	42.9	1.031	26.2
20A	32	1.750-18 UNS	1.250	31.8	0.469	11.9	2.031	51.6	2.031	51.6	1.094	27.8
24A	36	2.000-18 UNS	1.375	34.9	0.531	13.5	2.219	56.4	2.281	57.9	1.156	29.4
28A	40	2.250-16 UN	1.625	41.3	0.531	13.5	2.500	63.5	2.688	68.3	1.688	42.9
32A	44	2.500-16 UN	1.875	47.6	0.594	15.1	2.781	70.6	2.938	74.6	1.750	44.5
40A	48	3.00-16 UN	2.375	60.3	0.656	16.7	3.281	83.3	3.500	88.9	1.750	44.5

STRAIN RELIEF CLAMP

STRAIGHT; SELF-LOCK/NON SELF-LOCK

26482 Series II; 5015 (MS345X); 83723 Series III

MIL Part Number

M85049	/118	-	10	W
Series	Slash Sheet	Coupling	Dash Number (Table A)	Finish (Table 2, pg. 14)
	118: Straight	S: Self Lock -: Non Self Lock		

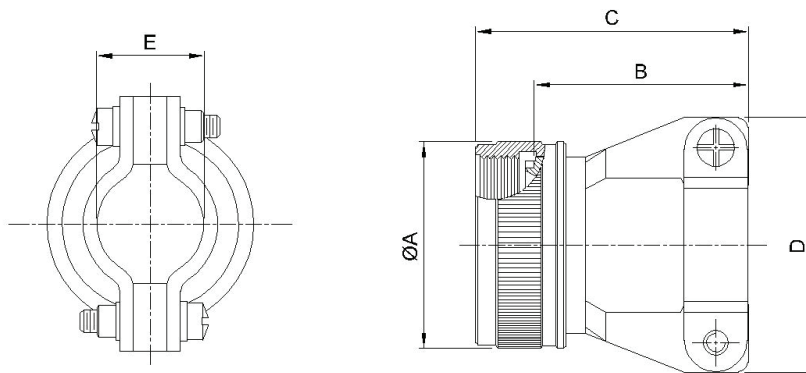

TABLE - A

MIL PART NUMBER DESIGNATOR	CONNECTOR SHELL SIZE/ CODE (REF.)	A DIA.(MAX)		B LENGTH		C (MAX)		D (MAX)		E (CLOSED)	
		INCH	MM	INCH	MM	INCH	MM	INCH	MM	±.031	±.787
CONNECTOR SHELL SIZE											
08	8S	0.89	22.61	0.77/0.51	19.56/12.95	1.14	28.96	0.88	22.35	0.22	5.56
10	10S, 10SL	1.01	25.65	0.89/0.64	22.61/16.26	1.25	31.75	0.94	23.88	0.26	6.71
12	12, 12S	1.14	28.96	1.01/0.76	25.65/19.30	1.38	35.05	1.12	28.45	0.34	8.74
14	14, 14S	1.26	32.00	1.01/0.76	25.65/19.30	1.38	35.05	1.19	30.23	0.46	11.68
16	16, 16S	1.39	35.31	1.13/0.88	28.70/22.35	1.50	38.10	1.44	36.58	0.55	13.84
18	18	1.51	38.35	1.38/1.13	35.05/28.70	1.75	44.45	1.56	39.62	0.62	15.62
20	20	1.64	41.66	1.51/1.25	38.35/31.75	1.88	47.75	1.69	42.93	0.69	17.53
22	22	1.76	44.70	1.62/1.38	41.15/35.05	2.00	50.80	1.75	44.45	0.78	19.81
24	24	1.89	48.01	1.76/1.51	44.70/38.35	2.13	54.10	1.88	47.75	0.85	21.59
28	28	2.14	54.36	2.03/1.67	51.56/42.42	2.56	65.02	2.12	53.85	0.95	24.13
32	32	2.40	60.96	2.28/1.87	57.91/47.50	2.81	71.37	2.50	63.50	1.02	25.78
36	36	2.64	67.06	2.53/2.22	64.26/56.39	3.06	77.72	2.62	66.55	1.19	30.15
40	40	2.89	73.41	2.63/2.41	66.80/61.21	3.16	80.26	2.68	68.07	1.22	30.99
44	44	3.14	79.76	3.00/2.80	76.20/71.12	3.53	89.66	3.00	76.20	1.50	38.10
48	48	3.39	86.11	3.40/3.20	86.36/81.28	3.93	99.82	3.50	88.90	1.63	41.28

STRAIN RELIEF CLAMP

90°; SELF-LOCK/NON SELF-LOCK

26482 Matrix Series II; 5015 Matrix (MS345X); 83723 Matrix & Pyle & Series III

MIL Part Number

M85049	/120	-	10	W
Series	Slash Sheet	Coupling	Dash Number (Table A)	Finish (Table 2, pg. 14)
	120: 90°	S: Self Lock -: Non Self Lock		

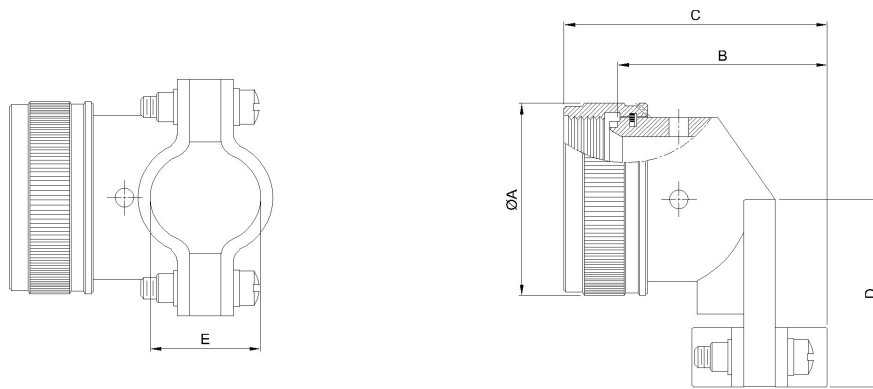

MIL PART NUMBER DESIGNATOR	CONNECTOR SHELL SIZE	A DIA.(MAX)		B (MAX)		C (MAX)		D (MAX)		E (CLOSED)	
		INCH	MM	INCH	MM	INCH	MM	INCH	MM	±.031	±.787
DASH NO											
08	8S	0.88	22.35	0.93	23.62	1.29	32.77	0.81	20.57	0.22	5.56
10	10S, 10SL	0.94	23.88	1.02	25.91	1.38	35.05	0.87	22.10	0.26	6.71
12	12, 12S	1.12	28.45	1.21	30.73	1.57	39.88	0.93	23.62	0.34	8.74
14	14, 14S	1.19	30.23	1.27	32.26	1.63	41.40	1.00	25.40	0.46	11.68
16	16, 16S	1.44	36.58	1.42	36.07	1.78	45.21	1.06	26.92	0.55	13.84
18	18	1.56	39.62	1.53	38.86	1.89	48.01	1.23	31.24	0.62	15.62
20	20	1.69	42.93	1.65	41.91	2.01	51.05	1.30	33.02	0.70	17.73
22	22	1.75	44.45	1.78	45.21	2.14	54.36	1.36	34.54	0.78	19.81
24	24	1.88	47.75	1.90	48.26	2.26	57.40	1.42	36.07	0.85	21.59
28	28	2.12	53.85	2.20	55.88	2.72	69.09	1.63	41.40	0.95	24.13
32	32	2.50	63.50	2.27	57.66	2.79	70.87	1.86	47.24	1.02	25.78
36	36	2.62	66.55	2.39	60.71	2.91	73.91	1.98	50.29	1.19	30.15
40	40	2.68	68.07	2.52	64.01	3.04	77.22	2.10	53.34	1.22	30.99
44	44	3.00	76.20	2.77	70.36	3.29	83.57	2.36	59.94	1.50	38.10
48	48	3.50	88.90	2.89	73.41	3.41	86.61	2.48	62.99	1.63	41.28

STRAIN RELIEF CLAMP

STRAIGHT
Mil-DTL-24308

MIL Part Number

M85049	/48	2	X	XX
Series	Slash Sheet	Straight	Dash Number (Table A)	Finish (Table 2, pg. 14)

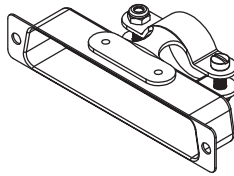
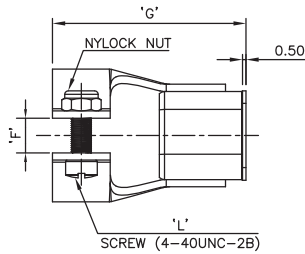
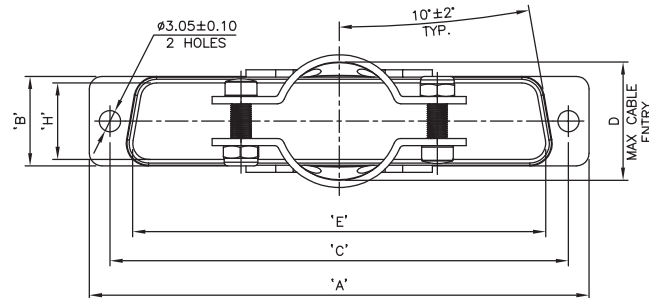

TABLE - A

Sr. No	MIL PART NUMBER DESIGNATOR	CONNECTOR SHELL SIZE	Number of Pins Density		A (MAX)	B (MAX)	C (MAX)	D (MAX)	L (MAX) (CLOSED)
			Std.	High					
			1	M2000/48-2-1Z					
2	M2000/48-2-2Z	2	15	26	39.00	12.40	33.32	10.30	27.80
3	M2000/48-2-3Z	3	25	44	52.90	12.40	47.04	15.10	28.60
4	M2000/48-2-4Z	4	37	62	69.20	12.40	63.50	18.30	28.60
5	M2000/48-2-5Z	5	50	78	66.80	15.25	61.11	18.30	28.60

STRAIN RELIEF CLAMP

STRAIGHT; 90°; SELF-LOCK/NON SELF-LOCK 38999 Series I & Series II

MIL Part Number

M85049	/47	-	10	W
Series	Slash Sheet	Coupling	Dash Number (Table A)	Finish (Table 2, pg. 14)
	49-2: Straight 47: 90°	S: Self Lock -: Non Self Lock		

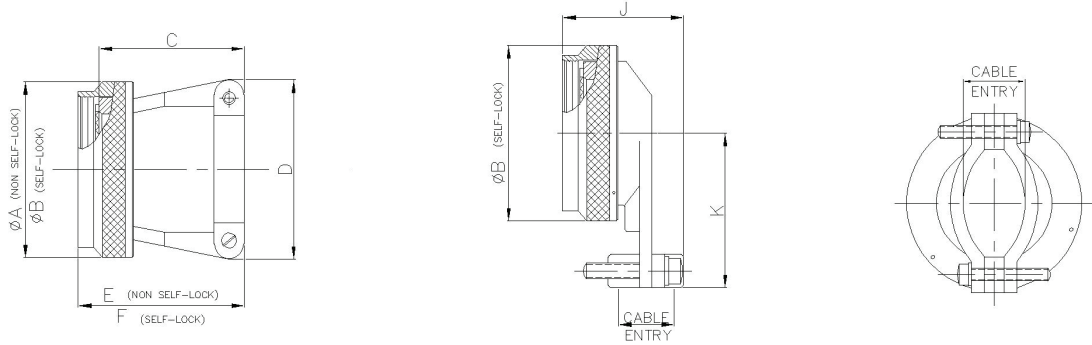

MIL PART NUMBER DESIGNATOR	CONNECTOR SHELL SIZE SE - II / I	A DIA.(MAX)		B DIA.(MAX)		C (MAX)		D (MAX)		E (MAX)		F (MAX)	
		INCH	MM	INCH	MM	INCH	MM	INCH	MM	INCH	MM	INCH	MM
08	8 / 9	0.75	19.05	0.86	21.82	0.91	23.11	0.85	21.59	1.10	27.94	1.15	29.21
10	10 / 11	0.85	21.59	0.98	24.99	0.91	23.11	0.90	22.86	1.10	27.94	1.15	29.21
12	12 / 13	1.00	25.40	1.16	29.36	1.01	25.65	1.10	27.94	1.20	30.48	1.25	31.75
14	14 / 15	1.10	27.94	1.28	32.54	1.06	26.92	1.15	29.21	1.25	31.75	1.30	33.02
16	16 / 17	1.25	31.75	1.41	35.71	1.16	29.46	1.30	33.02	1.36	34.44	1.40	35.56
18	18 / 19	1.40	35.56	1.52	38.51	1.41	35.81	1.50	38.10	1.60	40.64	1.65	41.91
20	20 / 21	1.50	38.10	1.64	41.68	1.51	38.35	1.60	40.64	1.70	43.21	1.75	44.45
24	22 / 23	1.65	41.91	1.77	44.86	1.66	42.16	1.70	43.18	1.85	46.99	1.90	48.26
24	24 / 25	1.75	44.45	1.89	48.03	1.76	44.70	1.80	45.72	1.95	49.56	2.00	50.80

MIL PART NUMBER DESIGNATOR	CONNECTOR SHELL SIZE SE - II / I	J (MAX)		K (MAX)		CABLE ENTRY			
		INCH	MM	INCH	MM	MIN		MAX	
						INCH	MM	INCH	MM
08	8 / 9	1.38	35.05	1.00	25.40	0.10	2.49	0.23	5.94
10	10 / 11	1.38	35.05	1.10	27.94	0.15	3.89	0.23	5.94
12	12 / 13	1.46	37.08	1.10	27.94	0.19	4.83	0.33	8.33
14	14 / 15	1.63	41.40	1.25	31.75	0.26	6.60	0.46	11.61
16	16 / 17	1.80	45.72	1.30	33.02	0.28	7.19	0.61	15.60
18	18 / 19	1.82	46.23	1.35	34.29	0.33	8.26	0.63	16.10
20	20 / 21	1.90	48.26	1.60	40.64	0.34	8.71	0.70	17.73
22	22 / 23	2.04	51.82	1.75	44.45	0.38	9.68	0.82	20.90
24	24 / 25	2.15	54.61	1.85	46.99	0.42	10.62	0.85	21.67

STRAIN RELIEF CLAMP

STRAIGHT; SELF-LOCK/NON SELF-LOCK

38999 Series I & Series II

MIL Part Number

M85049	/121	-	10	W
Series	Slash Sheet	Coupling	Dash Number (Table A)	Finish (Table 2, pg. 14)
	121: Straight	S: Self Lock -: Non Self Lock		

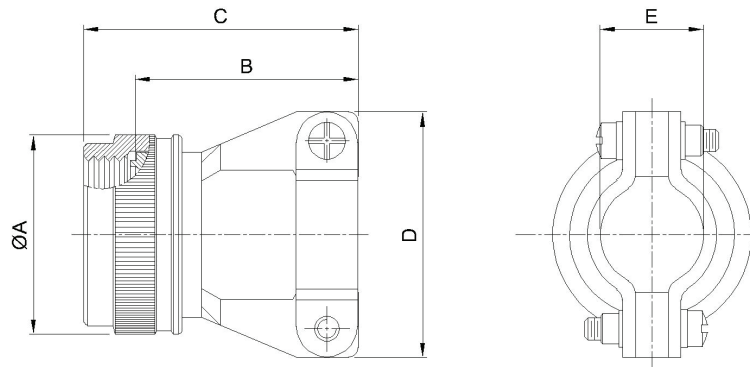

TABLE - A

MIL PART NUMBER DESIGNATOR	CONNECTOR SHELL SIZE SE - II / I	A DIA. (MAX)		B LENGTH		C (MAX)		D (MAX)		E (CLOSED)	
		INCH	MM	INCH	MM	INCH	MM	INCH	MM	±.031	±.787
DASH NO										INCH	MM
08	08	0.86	21.79	0.77/0.51	19.56/12.95	1.01	25.65	0.88	22.35	0.22	5.56
10	10	0.98	24.99	0.89/0.64	22.61/16.26	1.13	28.70	0.94	23.88	0.26	6.71
12	12	1.16	29.39	1.01/0.76	25.65/19.30	1.25	31.75	1.12	28.45	0.34	8.74
14	14	1.28	32.49	1.01/0.76	25.65/19.30	1.25	31.75	1.19	30.23	0.46	11.68
16	16	1.41	35.71	1.13/0.88	28.70/22.35	1.37	34.80	1.44	36.58	0.55	13.84
18	18	1.52	38.51	1.38/1.13	35.05/28.70	1.62	41.15	1.56	39.62	0.62	15.62
20	20	1.64	41.71	1.51/1.25	38.35/31.75	1.75	44.45	1.69	42.93	0.69	17.53
22	22	1.77	44.91	1.62/1.38	41.15/35.05	1.87	47.50	1.75	44.45	0.78	19.81
24	24	1.87	47.47	1.76/1.51	44.70/38.35	2.00	50.80	1.88	47.75	0.85	21.59

STRAIN RELIEF CLAMP

STRAIGHT; 90°; SELF-LOCK/NON SELF-LOCK
38999 Series I & Series II

MIL Part Number

M85049	/123	-	10	W
Series	Slash Sheet	Coupling	Dash Number (Table A)	Finish (Table 2, pg. 14)
	123: 90°	S: Self Lock -: Non Self Lock		

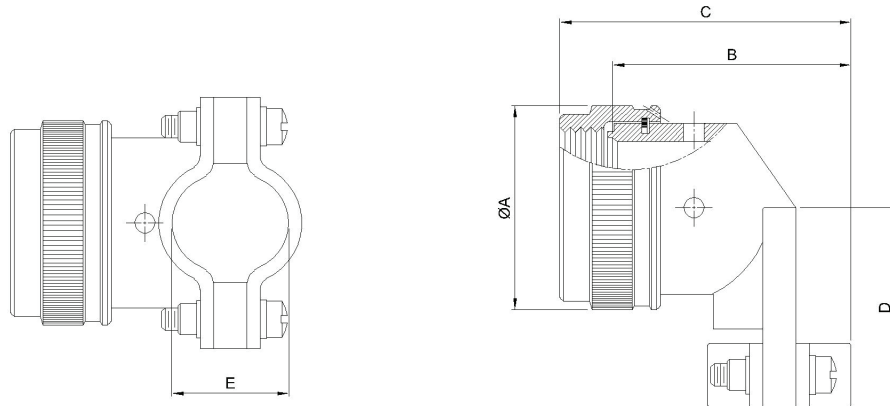

MIL PART NUMBER DESIGNATOR	CONNECTOR SHELL SIZE SE - II / I	A DIA.(MAX)		B (MAX)		C (MAX)		D (MAX)		E (CLOSED)	
		INCH	MM	INCH	MM	INCH	MM	INCH	MM	±.031	±.787
DASH NO										INCH	MM
08	08	0.86	21.79	0.86	21.84	1.10	27.94	0.81	20.57	0.22	5.56
10	10	0.98	24.99	0.94	23.88	1.18	29.97	0.87	22.10	0.26	6.71
12	12	1.16	29.39	1.14	28.96	1.38	35.05	0.93	23.62	0.34	8.74
14	14	1.28	32.49	1.20	30.48	1.44	36.58	0.99	25.15	0.46	11.68
16	16	1.41	35.71	1.34	34.04	1.58	40.13	1.06	26.92	0.55	13.84
18	18	1.52	38.51	1.46	37.08	1.70	43.18	1.23	31.24	0.62	15.62
20	20	1.64	41.71	1.58	40.13	1.82	46.23	1.30	33.02	0.70	17.73
22	22	1.77	44.91	1.71	43.43	1.95	49.53	1.36	34.54	0.78	19.81
24	24	1.87	47.47	1.83	46.48	2.07	52.58	1.42	36.07	0.85	21.59

STRAIN RELIEF CLAMP

STRAIGHT; 90°; SELF-LOCK/NON SELF-LOCK 38999 Series III & Series IV

MIL Part Number

M85049	/38	-	11	W
Series	Slash Sheet	Coupling	Shell Size (Table A)	Finish (Table 2, pg. 14)
	38: Straight 39: 90°	S: Self Lock -: Non Self Lock		

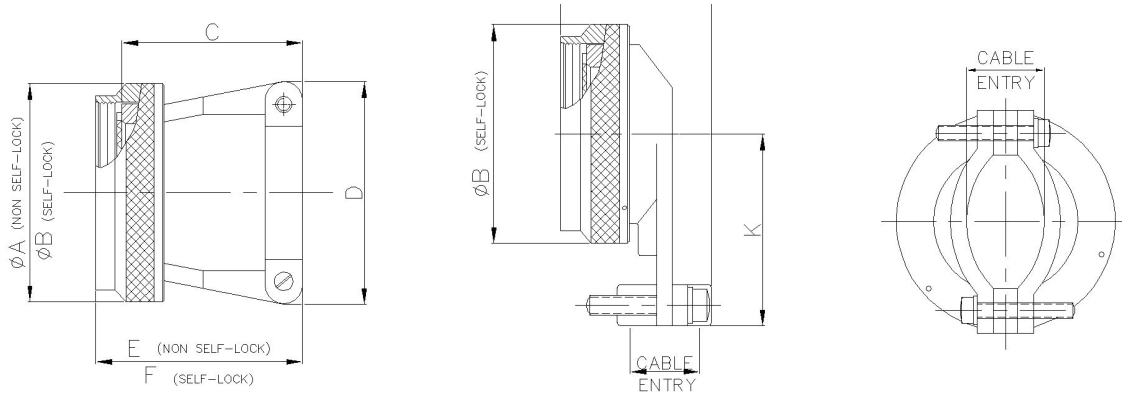

TABLE - A

MIL PART NUMBER DESIGNATOR	CONNECTOR SHELL SIZE/ CODE (REF.)	A DIA.(MAX)		B DIA.(MAX)		C (MAX)		D (MAX)		E (MAX)		F (MAX)	
		INCH	MM	INCH	MM	INCH	MM	INCH	MM	INCH	MM	INCH	MM
09	9 / A	0.75	19.05	0.86	21.82	0.91	23.11	0.85	21.59	1.10	27.94	1.21	30.73
11	11 / B	0.85	21.59	0.98	24.99	0.91	23.11	0.90	22.86	1.10	27.94	1.21	30.73
13	13 / C	1.00	25.40	1.16	29.36	1.01	25.65	1.10	27.94	1.20	30.48	1.31	33.27
15	15 / D	1.10	27.94	1.28	32.54	1.06	26.92	1.15	29.21	1.25	31.75	1.35	34.29
17	17 / E	1.25	31.75	1.41	35.71	1.16	29.46	1.30	33.02	1.36	34.44	1.45	36.83
19	19 / F	1.40	35.56	1.52	38.51	1.41	35.81	1.50	38.10	1.60	40.64	1.71	43.43
21	21 / G	1.50	38.10	1.64	41.68	1.51	38.35	1.60	40.64	1.70	43.21	1.81	45.97
23	23 / H	1.65	41.91	1.77	44.86	1.66	42.16	1.70	43.18	1.85	46.99	1.95	49.53
25	25 / J	1.75	44.45	1.89	48.03	1.76	44.70	1.80	45.72	1.95	49.56	2.05	52.07

TABLE - A, cont.

MIL PART NUMBER DESIGNATOR	CONNECTOR SHELL SIZE/ CODE (REF.)	J (MAX)		K (MAX)		CABLE ENTRY			
		INCH	MM	INCH	MM	MIN		MAX	
CONNECTOR SHELL SIZE						INCH	MM	INCH	MM
9	9 / A	1.31	33.27	1.00	25.40	0.10	2.49	0.23	5.94
11	11 / B	1.31	33.27	1.10	27.94	0.15	3.89	0.23	5.94
13	13 / C	1.51	38.35	1.10	27.94	0.19	4.83	0.33	8.33
15	15 / D	1.55	39.37	1.25	31.75	0.26	6.60	0.46	11.61
17	17 / E	1.71	43.43	1.30	33.02	0.28	7.19	0.61	15.60
19	19 / F	1.81	45.97	1.35	34.29	0.33	8.26	0.63	16.10
21	21 / G	1.95	49.53	1.60	40.64	0.34	8.71	0.70	17.73
23	23 / H	2.10	53.34	1.75	44.45	0.38	9.68	0.82	20.90
25	25 / J	2.21	56.13	1.85	46.99	0.42	10.62	0.85	21.67

STRAIN RELIEF CLAMP

STRAIGHT; SELF-LOCK/NON SELF-LOCK

38999 Series III & Series IV

MIL Part Number

M85049	/124	-	10	W
Series	Slash Sheet	Coupling	Dash Number (Table A)	Finish (Table 2, pg. 14)
	124: 90°	S: Self Lock -: Non Self Lock		

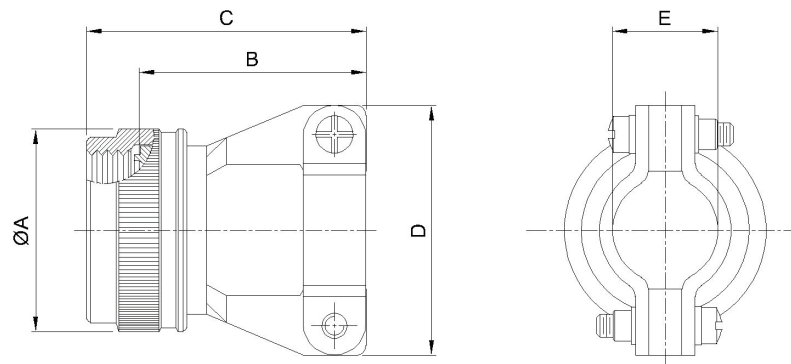

MIL PART NUMBER DESIGNATOR	CONNECTOR SHELL SIZE/ CODE (REF.)	A DIA.(MAX)		B LENGTH		C (MAX)		D (MAX)		E (CLOSED)	
		INCH	MM	INCH	MM	INCH	MM	INCH	MM	±.031	±.787
										INCH	MM
09	9 / A	0.86	21.79	0.77/0.51	19.56/12.95	1.01	25.65	0.88	22.35	0.22	5.56
11	11 / B	0.98	24.99	0.89/0.64	22.61/16.26	1.13	28.70	0.94	23.88	0.26	6.71
13	13 / C	1.16	29.39	1.01/0.76	25.65/19.30	1.25	31.75	1.12	28.45	0.34	8.74
15	15 / D	1.28	32.49	1.01/0.76	25.65/19.30	1.25	31.75	1.19	30.23	0.46	11.68
17	17 / E	1.41	35.71	1.13/0.88	28.70/22.35	1.37	34.80	1.44	36.58	0.55	13.84
19	19 / F	1.52	38.51	1.38/1.13	35.05/28.70	1.62	41.15	1.56	39.62	0.62	15.62
21	21 / G	1.64	41.71	1.51/1.25	38.35/31.75	1.75	44.45	1.69	42.93	0.69	17.53
23	23 / H	1.77	44.91	1.62/1.38	41.15/35.05	1.87	47.50	1.75	44.45	0.78	19.81
25	25 / J	1.87	47.47	1.76/1.51	44.70/38.35	2.00	50.80	1.88	47.75	0.85	21.59

STRAIN RELIEF CLAMP

90°; SELF-LOCK/NON SELF-LOCK
38999 Series III & Series IV

MIL Part Number

M85049	/126	-	11	W
Series	Slash Sheet	Coupling	She Size (Table A)	Finish (Table 2, pg. 14)
	126: 90°	S: Self Lock -: Non Self Lock		

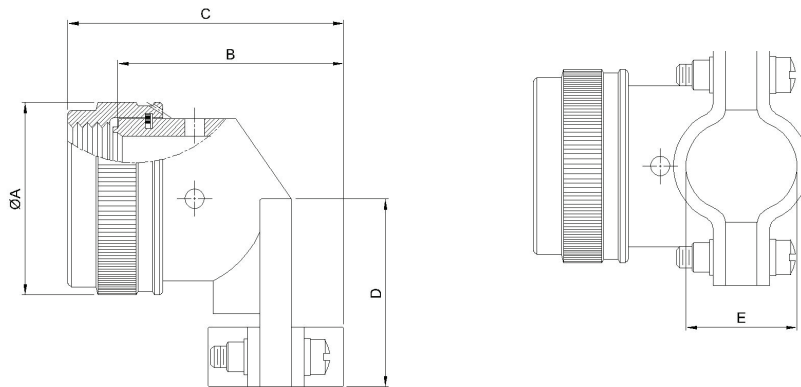

TABLE - A

MIL PART NUMBER DESIGNATOR	CONNECTOR SHELL SIZE/ CODE (REF.)	A DIA.(MAX)		B LENGTH		C (MAX)		D (MAX)		E (CLOSED)	
		INCH	MM	INCH	MM	INCH	MM	INCH	MM	±.031	±.787
										INCH	MM
09	9 / A	0.86	21.79	0.77/0.51	19.56/12.95	1.01	25.65	0.88	22.35	0.22	5.56
11	11 / B	0.98	24.99	0.89/0.64	22.61/16.26	1.13	28.70	0.94	23.88	0.26	6.71
13	13 / C	1.16	29.39	1.01/0.76	25.65/19.30	1.25	31.75	1.12	28.45	0.34	8.74
15	15 / D	1.28	32.49	1.01/0.76	25.65/19.30	1.25	31.75	1.19	30.23	0.46	11.68
17	17 / E	1.41	35.71	1.13/0.88	28.70/22.35	1.37	34.80	1.44	36.58	0.55	13.84
19	19 / F	1.52	38.51	1.38/1.13	35.05/28.70	1.62	41.15	1.56	39.62	0.62	15.62
21	21 / G	1.64	41.71	1.51/1.25	38.35/31.75	1.75	44.45	1.69	42.93	0.69	17.53
23	23 / H	1.77	44.91	1.62/1.38	41.15/35.05	1.87	47.50	1.75	44.45	0.78	19.81
25	25 / J	1.87	47.47	1.76/1.51	44.70/38.35	2.00	50.80	1.88	47.75	0.85	21.59

HEXAGON PANEL NUT FOR SER-III & IV

MIL Part Number

J D38999	/28	11	F
			Class
MIL Number prefix I	Specification sheet number	Dash Number	F - Electroless nickel finish. W- Aluminum, 500 hrs cadmium olive drab

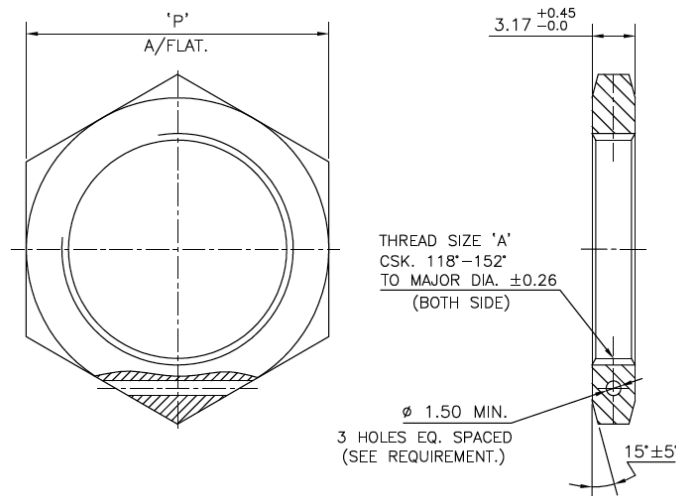

Dash #	Shell Size		"A" Thread Size	Modified	P Hex.
	Ser-III	Ser-IV			
1	09	--	M17 X 1-6H	16.04/16.15	24.0 21.82
2	11	--	M20 X 1-6H	19.07/19.15	27.0 24.99
3	13	11	M25 X 1-6H	---	32.0 29.77
4	15	12	M28 X 1-6H	---	36.0 32.91
5	--	15	M31 X 1-6H	---	41.0 39.26
6	17	--	M32 X 1-6H	---	37.0 36.12
7	--	17	M34 X 1-6H	---	41.0 39.25
8	19	--	M35 X 1-6H	---	41.0 39.25
9	21	19	M38 X 1-6H	---	46.0 42.47
10	23	21	M41 X 1-6H	---	50.0 45.61
11	25	23	M44 X 1-6H	---	51.0 49.25
12	--	23	M47 X 1-6H	---	55.0 53.54

MIL Part Number

D38999	/22	B	W
MIL Number prefix	Specification sheet number	Shell size code	Class
			Shell size codes A, A1 and A2 for shell size 9 only: <ul style="list-style-type: none"> • Shell size code A is a universal configuration for use with plugs with mating key polarizations A, B, C, D, E and N. • Shell size code A1 is for use with plugs with mating key polarizations C, E or N. • Shell size code A2 is for use with plugs with mating key polarizations A, B or D.

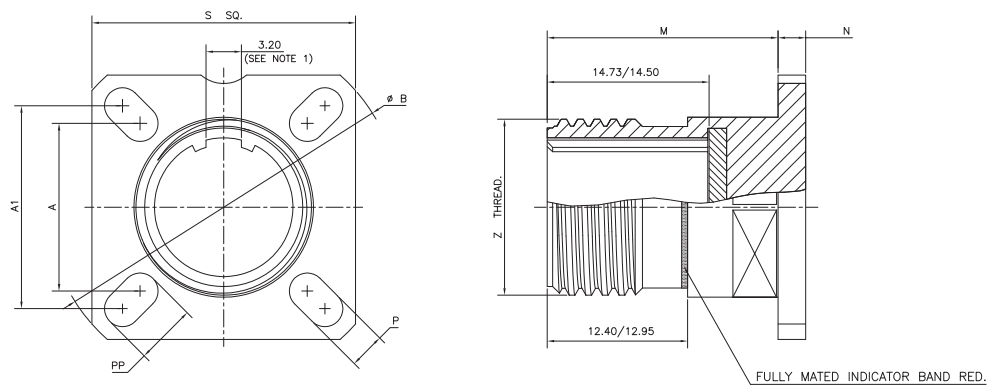

Shell Size	Class	S .3	V +0.00 -0.13	V' +1.4 -0.0	W 3	W'
9	A	23.8 (.937)	20.83 (.820)	19.5 (.768)	2.5 (.098)	3.65 (.144) 2.2 (.087)
9	A	23.8 (.937)	20.83 (.820)	19.5 (.768)	2.5 (.098)	3.65 (.144) 2.2 (.087)
9	A	23.8 (.937)	20.83 (.820)	19.5 (.768)	2.5 (.098)	3.65 (.144) 2.2 (.087)
11	B	26.2 (1.031)	20.83 (.820)	19.5 (.768)	2.5 (.098)	3.65 (.144) 2.2 (.087)
13	C	28.6 (1.126)	20.83 (.820)	19.5 (.768)	2.5 (.098)	3.65 (.144) 2.2 (.087)
15	D	31.0 (1.220)	20.83 (.820)	19.5 (.768)	2.5 (.098)	3.65 (.144) 2.2 (.087)
17	E	33.3 (1.311)	20.83 (.820)	19.5 (.768)	2.5 (.098)	3.65 (.144) 2.2 (.087)
19	F	36.5 (1.437)	20.83 (.820)	19.5 (.768)	2.5 (.098)	3.65 (.144) 2.2 (.087)
21	G	39.7 (1.563)	20.07 (.790)	18.7 (.736)	3.2 (.126)	4.35 / 2.9 (.171 / .114)
23	H	42.9 (1.689)	20.07 (.790)	18.7 (.736)	3.2 (.126)	4.35 / 2.9 (.171 / .114)
25	J	46.0 (1.811)	20.07 (.790)	18.7 (.736)	3.2 (.126)	4.35 / 2.9 (.171 / .114)

STRAIGHT, 90°

Composite

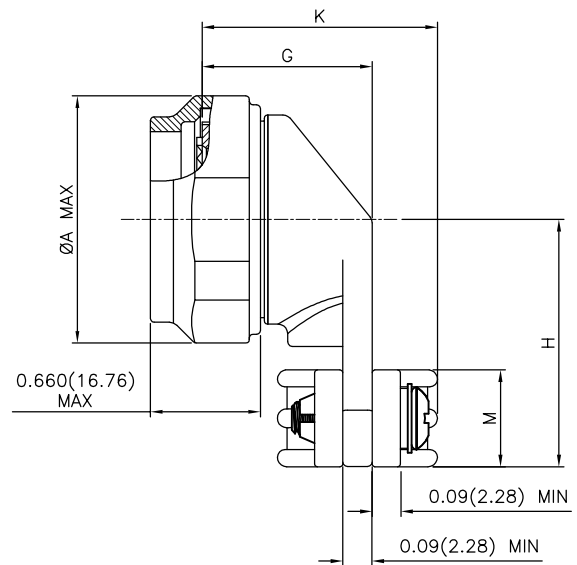
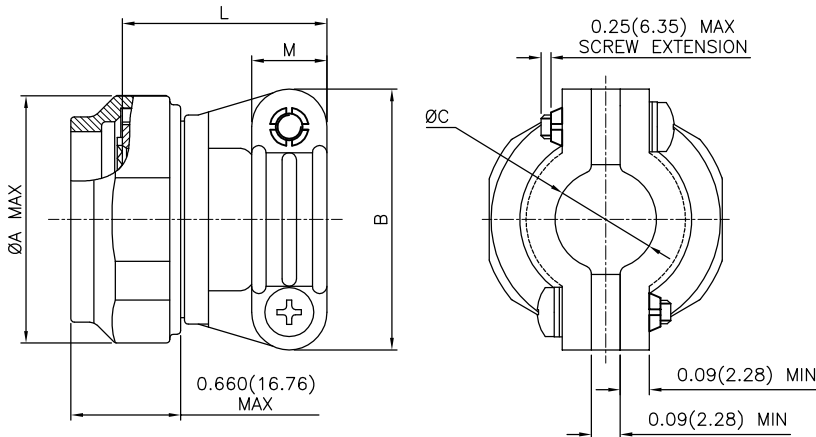

PART NUMBER

M85049/ 91 - 11 T

- Basic part number ————
- Specification sheet ————
- 91 - Straight
- 92 - 90°
- Composite without plating ————
- Shell size (Table A) ————
- Detented self locking ————

TABLE A

SHELL SIZE	A DIA MAX		B MAX		C DIA ±0.031(0.78)	
	INCH	MM	INCH	MM	INCH	MM
09	0.858	21.79	0.980	24.89	0.219	5.56
11	0.984	24.99	1.050	26.67	0.264	6.71
13	1.157	29.39	1.200	30.48	0.344	8.74
15	1.280	32.51	1.300	33.02	0.460	11.68
17	1.406	35.71	1.420	36.07	0.545	13.84
19	1.516	38.51	1.520	38.61	0.615	15.62
21	1.642	41.71	1.640	41.66	0.698	17.73
23	1.768	44.91	1.770	44.96	0.780	19.81
25	1.890	48.01	1.890	48.01	0.850	21.59

Table continued..

TABLE A

L MAX		H ±0.062(1.57)		K MAX		M ±0.03(0.76)		G MAX		SCREW SIZE
INCH	MM	INCH	MM	INCH	MM	INCH	MM	INCH	MM	
0.840	21.34	0.875	22.23	1.060	26.92	0.375	9.53	0.769	19.53	4-40
0.960	24.38	0.937	23.80	1.100	27.94	0.375	9.53	0.792	20.12	4-40
1.100	27.94	1.031	26.19	1.180	29.97	0.406	10.31	0.847	21.51	6-32
1.100	27.94	1.125	28.58	1.300	33.02	0.406	10.31	0.890	22.61	6-32
1.230	31.24	1.312	33.32	1.380	35.05	0.406	10.31	0.941	23.90	6-32
1.410	35.81	1.375	34.93	1.450	36.83	0.406	10.31	0.972	24.69	6-32
1.510	38.35	1.500	38.10	1.540	39.12	0.406	10.31	1.009	25.63	6-32
1.660	42.16	1.625	41.28	1.620	41.15	0.406	10.31	1.050	26.67	6-32
1.760	44.70	1.750	44.45	1.690	42.93	0.406	10.31	1.085	27.56	6-32

MATERIAL -

Coupling nut, strain relief and strap - Composite in accordance with AS85049

Captivated self-locking telescoping screw and washers - 300 Series corrosion resistant steel / passivated, silver plate optional.

COMPOSITE SPLIT RING

STRAIGHT

Composite

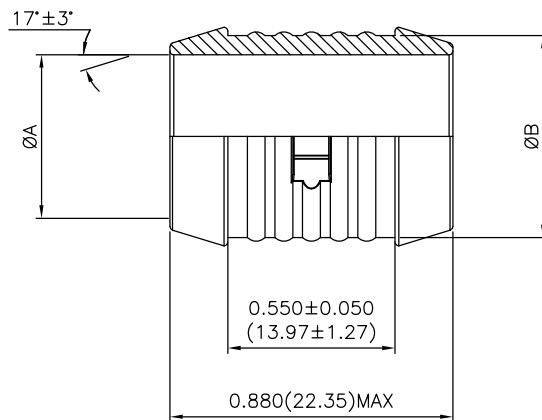

PART NUMBER

M85049/ 93 - 14

Basic part number

Specification sheet

Dash Number (Table A)

TABLE A

DASH NUMBER	A DIA $\pm 0.010(0.254)$		B DIA MAX	
	INCH	MM	INCH	MM
04	0.250	6.35	0.390	9.9
06	0.375	9.53	0.515	13.1
08	0.500	12.70	0.640	16.3
10	0.625	15.88	0.770	19.6
12	0.750	19.05	0.903	22.9
14	0.875	22.23	1.094	27.8
16	1.000	25.40	1.173	29.8
18	1.125	28.58	1.310	33.3
20	1.250	31.75	1.447	36.8
22	1.375	34.93	1.578	40.1
24	1.500	38.10	1.703	43.3
26	1.625	41.28	1.828	46.4
28	1.750	44.45	1.953	49.6

MATERIAL -

Composite in accordance with AS85049

NOTE-

For complete dimensions, see the applicable Military Specification

APPENDIX

Military Series	Amphenol Series	Page			
M85049/6	BV1BRJ	38	M85049/78	BV1BRL	48
M85049/7	BE1BRJ	33	M85049/79	BV1ARL	48
M85049/8	BV1ARJ	38	M85049/82	BL1SSJ	16
M85049/9	BE1ARJ	33	M85049/83	BL1BSJ	16
M85049/10	BV1SRJ	35	M85049/84	BL1ASJ	16
M85049/11	BE1SRJ	30	M85049/85	BL1SSK	17
M85049/14	BG1SRL	52	M85049/86	BL1BSK	17
M85049/15	BQ1BRL	75	M85049/87	BL1ASK	17
M85049/16	BQ1ARL	75	M85049/88	BL1SSL	18
M85049/17	BV1SDK	40	M85049/89	BL1BSL	18
M85049/18	BV1SRL	45	M85049/90	BL1ASL	18
M85049/19	BM1SRL	67	M85049/109	BH1SRJ	70
M85049/20	BC2SRL	21	M85049/111	BH1ARJ	70
M85049/21	BN1SRL	56	M85049/112	BH1SRK	71
M85049/23	BM1BRJ	62	M85049/114	BH1ARK	71
M85049/24	BM1ARJ	62	M85049/115	BH1SRL	72
M85049/25	BM1SRJ	59	M85049/117	BH1ARL	72
M85049/26-1	BC2SRJ	19	M85049/118	BS014SSJ	82
M85049/26-2	BC3XXX	19	M85049/120	BS014ASJ	83
M85049/26-3	BC1SRJ	19	M85049/121	BS014SSK	86
M85049/27	BG1SRK	57	M85049/123	BS014ASK	87
M85049/29	BN1SDK	53	M85049/124	BS014SS	89
M85049/31	BG1SRJ	50	M85049/126	BS014ASL	90
M85049/33-2	BC2SRK	20			
M85049/36	BM1SDK	64			
M85049/38	BS1SRL	88			
M85049/39	BS1ARL	88			
M85049/42	-	81			
M85049/43	BS1BRJ	79			
M85049/47	BS1ARK	85			
M85049/49-2	BS1SRK	85			
M85049/51	BS1ARJ	79			
M85049/52	BS1SRJ	79			
M85049/53	BQ1SRJ	73			
M85049/54	BQ1BRJ	73			
M85049/55	BQ1ARJ	73			
M85049/56	BQ1SRK	74			
M85049/57	BQ1BRKBB1SRJ	74			
M85049/60-1	BB1SRJ	76			
M85049/60-2	BB2SRJ	76			
M85049/62	BB1SRK	77			
M85049/63	BQ1ARK	74			
M85049/69	BB1SRL	78			
M85049/76	BV1ARK	43			
M85049/77	BV1BRK	43			

USA

Amphenol Pcd

72 Cherry Hill Dr.
Beverly, MA 01915 USA
1.978.624.3400
info@amphenolpcd.com
www.amphenolpcd.com
www.backshellworld.com

Germany

Amphenol AirLB GmbH

Am Kleinbahnhof 4 Saarlouis
D-66740, Germany
49.6831.9810.00
www.amphenol-airlb.de

India

Amphenol Interconnect India

105, Bhosari Industrial Area
Pune-411 026, India
91.20.3068.8304
www.amphenol-in.com

United Kingdom

Amphenol Limited

Thanet Way, Whitstable
Kent, CT5 3JF, UK
44.1227.773.200
www.amphenol.co.uk

France

Amphenol Socapex

2 rue, Clément Ader
ZAC de Wé
08110 Carignan
33.04.5089.2800
www.amphenol-socapex.com

Amphenol AirLB France

29 Voie d' Yvois
F-08110 Blagny, France
33.03.2422.3266
www.amphenol-airlb.fr

China

Amphenol Pcd Shenzhen

Building 21, 1st Liao Keng Industrial Zone,
Shi Yan Street Industrial Park
Ba An District Shenzhen, China 518108
86.755.8173.8000
www.amphenolpcd.com.cn

AMPHENOL PRODUCTS



Backshells



Cable Solutions & Cable Adapters
NEW

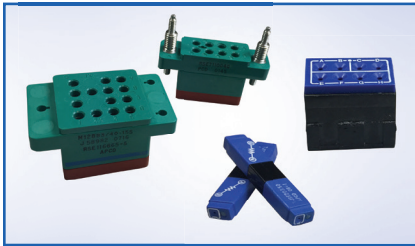

Relay Sockets & Junction Modules

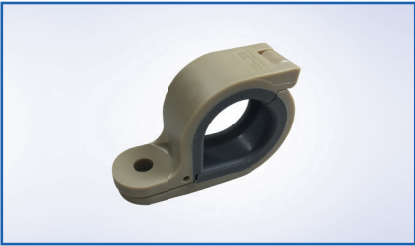

System Attachments



Luminus Series, Rayzor Series & Pegasus Series
NEW

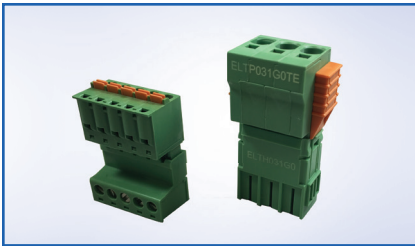

Terminal Blocks

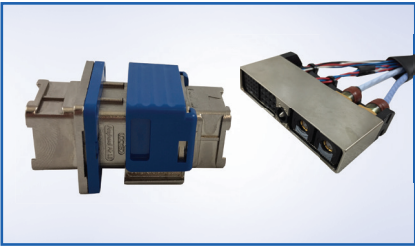

SIM



Rectangular



Circular



Waterproof Solutions



Rugged Solutions



Military Audio /Power

Amphenol Japan

Connecting People & Technology

Amphenol アンフェノール ジャパン株式会社

- 本社・工場 〒520-3041 滋賀県栗東市出庭471-1
TEL 077-553-8503・FAX 077-551-2200
- 横浜オフィス 〒222-0033 神奈川県横浜市港北区新横浜2-2-8
TEL 045-473-9219・FAX 045-473-9204

<http://www.amphenol.co.jp/military>

QPL Backshells

Amphenol Japan

本社・工場

〒520-3041 滋賀県栗東市出庭471-1
TEL 077-553-8503(代)・FAX 077-551-2200

横浜オフィス

〒222-0033 神奈川県横浜市港北区新横浜2-2-8
TEL 045-473-9219(代)・FAX 045-473-9204

X-ON Electronics

Largest Supplier of Electrical and Electronic Components

Click to view similar products for [Circular MIL Spec Backshells](#) category:

Click to view products by [Amphenol](#) manufacturer:

Other Similar products are found below :

[5M2919-3DW](#) [5M2953-1HW](#) [5PTC0023-28C](#) [5PTV7106-AC](#) [5PTV7107-HC](#) [610HS012M15](#) [M28840/805WB](#) [M28840/815WA](#)
[655HS002NF11](#) [CW3899-000](#) [M85049/10-134S](#) [M85049/10-17S](#) [M85049/120-14W](#) [M85049/6-19N](#) [M85049/79-25N04](#) [M85049/81-10](#)
[M85049/85-24P01](#) [M85049/88-19P02](#) [M85049/88-21P02](#) [M85049/89-11P03](#) [M85049/90-11J03](#) [M85049/90-19P02](#) [M85049/92-09T](#) [801-](#)
[005-02Z19-19PA](#) [84030008](#) [8500-2472](#) [900](#) [85202A14](#) [FRCIR020R-16-10P-F80-T108-VO](#) [8D105B02](#) [G8234-24D](#) [1234-258-09228](#) [1234-](#)
[259-19228](#) [1234-206-11192](#) [1234-259-11192](#) [1234-259-21228](#) [1234-279-19228](#) [1234-279-23228](#) [D38999/46WF35SNLC](#) [BACC10HG24C](#)
[BACC10JP22B](#) [189HS011-15053](#) [189HS016NF1907-3](#) [205M520-19C](#) [C8824-3W25](#) [91A3-20-11-1-B-HE200](#) [30-269-1P15F09](#)
[189HS016NF1105-3](#) [189HS016NF2111-3](#) [CF7294-000](#) [290WS003G-1406H3](#)