

SYN		REVISIONS	
ZONE	NO.	DESCRIPTION	DATE
B		RELEASED TO PRODUCTION EGN# HK585	

CONTACT CONFIGURATION FOR EVEN POSITION

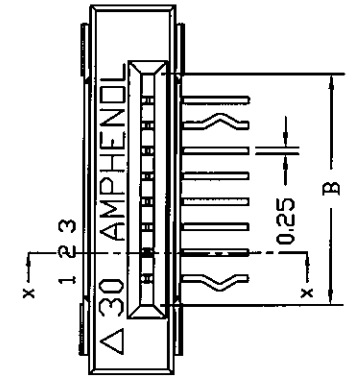
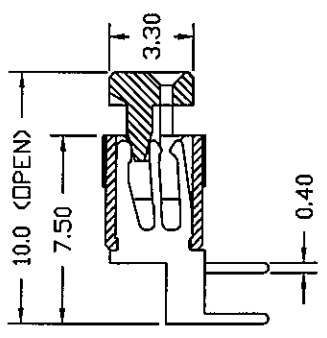

**PART NUMBER SYSTEM**  
 C007-10X-XXX-X/X 0 X

FPC SERIES  
 FLEXPRINT  
 THK=0.3MM  
 PITCH  
 B : 1.00 MM  
 E : 1.25 MM

CONTACT PLATING  
 0 : TIN/LEAD  
 1 : GOLD FLASH

TERMINATIONS  
 -0X01 : DIP SOLDER PIN, STRAIGHT  
 -1X01 : DIP SOLDER PIN, RIGHT ANGLED  
 -0X02 : SMT PIN, RIGHT ANGLED  
 -1X02 : SMT PIN, STRAIGHT

NO. OF WAYS  
 N : SEE TABLE I

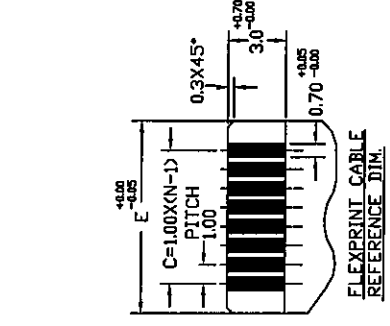
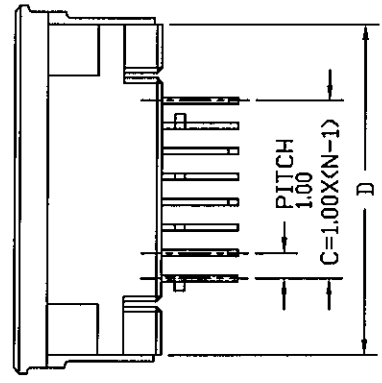

-TABLE I-

PART NUMBERS	NO OF WAYS (N)	A	B	C	D	E
C007-10B-005-1001	5	11.50	6.10	4.00	10.00	6.10
C007-10B-008-1001	8	14.50	9.10	7.00	13.00	9.10
C007-10B-010-1001	10	16.50	11.10	9.00	15.00	11.10
C007-10B-012-1001	12	18.50	13.10	11.00	17.00	13.10
C007-10B-014-1001	14	20.50	15.10	13.00	19.00	15.10
C007-10B-016-1001	16	22.50	17.10	15.00	21.00	17.10
C007-10B-017-1001	17	23.50	18.10	16.00	22.00	18.10
C007-10B-018-1001	18	24.50	19.10	17.00	23.00	19.10
C007-10B-020-1001	20	26.50	21.10	19.00	25.00	21.10
C007-10B-021-1001	21	27.50	22.10	20.00	26.00	22.10
C007-10B-022-1001	22	28.50	23.10	21.00	27.00	23.10
C007-10B-024-1001	24	30.50	25.10	23.00	29.00	25.10
C007-10B-025-1001	25	31.50	26.10	24.00	30.00	26.10
C007-10B-026-1001	26	32.50	27.10	25.00	31.00	27.10
C007-10B-030-1001	30	36.50	31.10	29.00	35.00	31.10

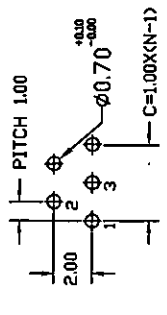

RECOMMENDED PCB LAYOUT FOR ODD POSITION

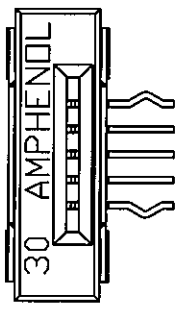

CONTACT CONFIGURATION FOR ODD POSITION

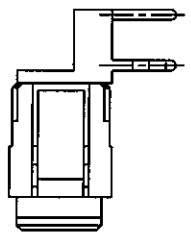

UNLESS OTHERWISE SPECIFIED  
 TOLERANCES U.S.  
 X +/-  
 XX +/-  
 XXX +/-  
 ANGLES +/-

APPROVAL DATE  
 DRAWN Y.M. LEE  
 CHECKED Y.M. LEE  
 APPR.  
 APPR.  
 APPR.

ANGLE OF PROJECTION

REMOVE SHARP EDGES  
 DIMENSIONS  
 INCHES  
 OMO

AMPHENOL  
 Amphenol East Asia Limited  
 Manufacturing Operation

TITLE  
 FPC, RIGHT ANGLE  
 DIP SOLDER PIN

SIZE DRAWING NO.  
 B C007-10B-XXX-1X01

SCALE NONE

SHEET 1 OF 1

THE DESIGNER IS THE SOLE AUTHORITY OF AMPHENOL CORPORATION AND IS RESPONSIBLE FOR THE DESIGN OF THE PRODUCT. THE USER SHALL BE RESPONSIBLE FOR THE SELECTION OF THE APPROPRIATE PART NUMBER AND THE USE OF THE PRODUCT IN THE END USER'S APPLICATION.

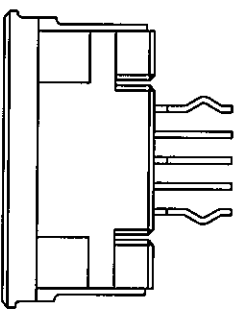
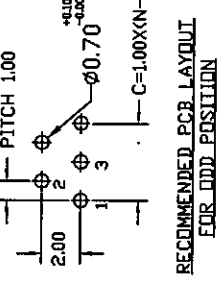
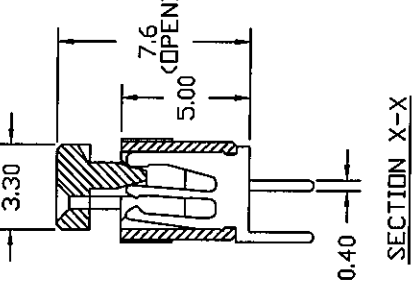
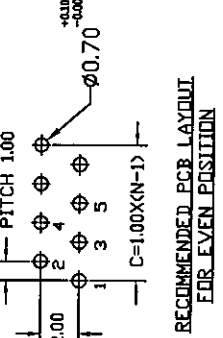
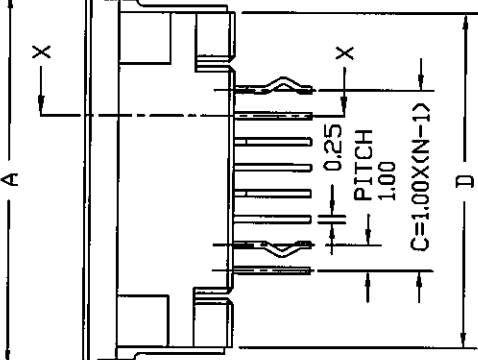
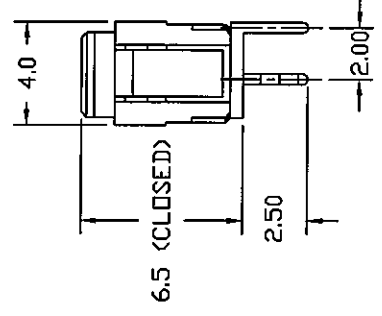
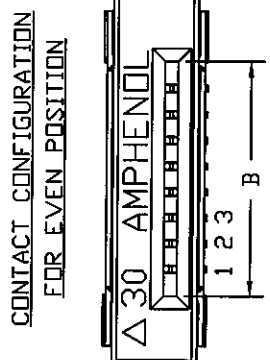
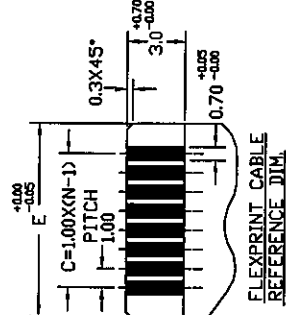

**PART NUMBER SYSTEM**

C007-10X-XXX-X X 0 X

**FPC SERIES**  
 FLEXPRINT THK=0.3MM  
 PITCH  
 B : 1.00 MM  
 E : 1.25 MM

**NO. OF WAYS**  
 N : SEE TABLE I

**TERMINATIONS**  
 -0X01 : DIP SOLDER PIN, STRAIGHT  
 -1X01 : DIP SOLDER PIN, RIGHT ANGLED  
 -0X02 : SMT PIN, RIGHT ANGLED  
 -1X02 : SMT PIN, STRAIGHT

**CONTACT PLATING**  
 0 : TIN/LEAD  
 1 : GOLD FLASH

**VARIATION**

-TABLE I-

PART NUMBERS	NO. OF WAYS (N)	A	B	C	D	E
C007-10B-005-0001	5	11.50	6.10	4.00	10.00	6.10
C007-10B-008-0001	8	14.50	9.10	7.00	13.00	9.10
C007-10B-010-0001	10	16.50	11.10	9.00	15.00	11.10
C007-10B-012-0001	12	18.50	13.10	11.00	17.00	13.10
C007-10B-014-0001	14	20.50	15.10	13.00	19.00	15.10
C007-10B-016-0001	16	22.50	17.10	15.00	21.00	17.10
C007-10B-017-0001	17	23.50	18.10	16.00	22.00	18.10
C007-10B-018-0001	18	24.50	19.10	17.00	23.00	19.10
C007-10B-020-0001	20	26.50	21.10	19.00	25.00	21.10
C007-10B-021-0001	21	27.50	22.10	20.00	26.00	22.10
C007-10B-022-0001	22	28.50	23.10	21.00	27.00	23.10
C007-10B-024-0001	24	30.50	25.10	23.00	29.00	25.10
C007-10B-025-0001	25	31.50	26.10	24.00	30.00	26.10
C007-10B-026-0001	26	32.50	27.10	25.00	31.00	27.10
C007-10B-030-0001	30	36.50	31.10	29.00	35.00	31.10

\* PENDING

REV. ZONE	DESCRIPTION	DATE	APPROVED
B	RELEASED TO PRODUCTION ECM# HKS85	1/19/87	

UNLESS OTHERWISE SPECIFIED TOLERANCES U.S. METRIC

X ±.015  
 XX ±.010  
 XXX ±.005  
 ANGLES ±.1°

FINISHES: 1 - SEE NOTES

REMOVE SHARP EDGES

DIMENSIONS: INCHES, MM

APPROVAL: DRAWN Y.M. LEE, CHECKED H.M. LEE, APPR. [Signatures]

DATE: [Blank]

Amphenol

Approved East Asia Limited Manufacturing Operations

TITLE: FPC, STRAIGHT DIP SOLDER PIN

SIZE DRAWING NO. B C007-10B-XXX-0X01

SCALE: NONE

SHEET 1 OF 1

## X-ON Electronics

Largest Supplier of Electrical and Electronic Components

*Click to view similar products for [Memory Card Connectors](#) category:*

*Click to view products by [Amphenol](#) manufacturer:*

Other Similar products are found below :

[M21-033321-005](#) [6407-249V-25273P](#) [6407-249V-25343P](#) [69.920.0553.0](#) [DM3AT-SF-PEJM5\(41\)](#) [HMCAP001](#) [2041353-2](#) [33CFAE-DN](#) [10-629549-258N](#) [617230001](#) [95622-003LF](#) [N7E50-U516RB-50-SIN0005](#) [95079-00CALF](#) [84648-056HLF](#) [125A-78C00](#) [MI20A-50PD-SF-EJL\(71\)](#) [KP10S-SF-PEJ\(812\)](#) [504536-0691](#) [CCM03-3109 B LFT](#) [MI21-50PD-SF\(91\)](#) [2309923-1](#) [IC1GA-68PD-1.27DS-EJ\(72\)](#) [GTFP08432B1HR](#) [G85DT17001P1EU](#) [G85C11101152HHR](#) [G85D1160022HHR](#) [XKSMO-072-P9](#) [XKNANO-1131-18](#) [XKSIM-1130-1](#) [XKNANO-1131-1](#) [XKTF-1152-1](#) [XKSMC-1200-200](#) [XKSD-1250-1](#) [XKTF-1307-16](#) [XKTF-1250-21](#) [XKNANO-1131-K](#) [XKTF-7131-1](#) [XKNANO-1308](#) [XKTF-1251-1](#) [XKTF-1230-51](#) [XKSD-1250-DS28](#) [XKNANO-1131-04](#) [XKSD-1250-29](#) [XKSD-1251-5C1](#) [XKSMC-1200-145](#) [SD-109-ACP13H16](#) [TF-123B-ARP9H17](#) [TF-123B-ARP9H15](#) [TF-123-ARP9H17](#) [TF-123-ARP9H15](#)