

# ELFP SERIES PART NUMBERING SCHEME

REV	ECN	APPD
-	3600	JEC 12/11/98
A	3865	JEC 11/9/99
B	4686	IQ 1/2/02
C	4761	IQ 2/20/02
D	4821	IQ 4/4/02
E	5742	2W 12/28/05

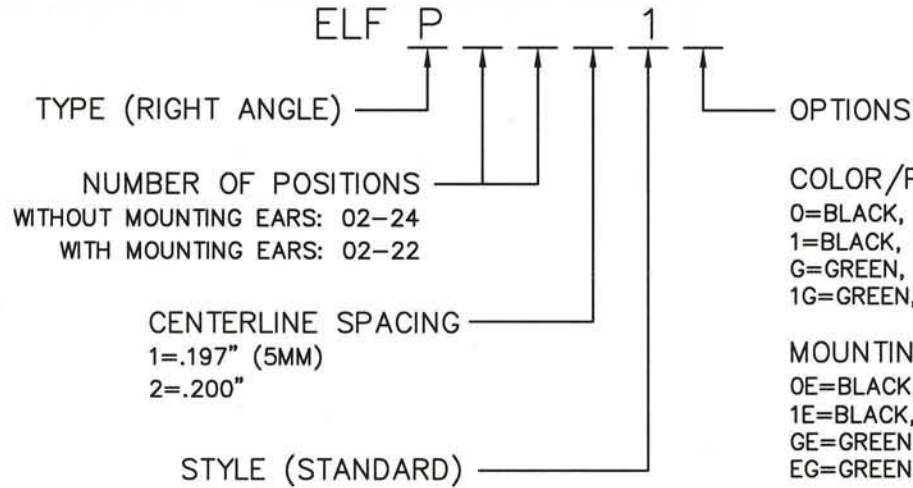

**COLOR/PLATING**  
 0=BLACK, TIN (STANDARD)  
 1=BLACK, SELECTIVE GOLD  
 G=GREEN, TIN  
 1G=GREEN, SEL. GOLD

**MOUNTING EARS**  
 OE=BLACK, TIN  
 1E=BLACK, SEL. GOLD  
 GE=GREEN, TIN  
 EG=GREEN, SEL. GOLD

CONSULT PCD FOR PART NO. AND AVAILABILITY OF FOLLOWING OPTIONS:

- \* CUSTOM COLORS
- \* CUSTOM MARKING
- \* CUSTOM KEYING
- \* SELECTIVE CONTACT LOADING

**UL RATINGS**  
 CURRENT - 15A  
 VOLTAGE - 300V  
 U.L. FILE NO. E83421

**SA RATINGS**  
 CURRENT - 15A  
 VOLTAGE - 300V  
 CSA FILE NO. LR69703

DIN VDE 0627:1986  
 DIN VDE 0110-1:1989  
 EN 60947-1:1991  
 EN 60947-7-1:1992  
 CURRENT - 15A  
 VOLTAGE - 300 V  
 TUV FILE NO. 20396

**INSTALLATION RECOMMENDATIONS:**  
 WIRE RANGE: AWG #14-26, STRANDED OR SOLID; AWG #12 STRANDED  
 WIRE STRIP LENGTH: .310"  
 TIGHTENING TORQUE: 7 LB-IN.

**MATERIALS:**  
 HOUSING: PPO, UL 94 V-0  
 CONTACT: COPPER ALLOY, OPTIONAL FINISH  
 SCREW: STEEL, NICKEL FINISH  
 WIRE CLAMP: COPPER ALLOY, NICKEL FINISH  
 OPERATING TEMPERATURE RANGE:  
 -40°C-95°C

<b>DIMENSIONS</b> ANSI Y14.5M UNITS: INCHES ACAD FILE	<b>TOLERANCES</b> .XX ±.01 .XXX ±.005 ANGLES ±2°	<b>PROJECTION</b> 	<b>Amphenol Pcd</b> SPECIFICATION DRAWING		<b>TITLE</b> ELFP SERIES PLUGGABLE TERMINAL BLOCK, RIGHT ANGLE			
			ENGR J. WILKINSON 11/8/98					SIZE A
ORIGINAL STAMPED IN RED	THIS DOCUMENT CONTAINS PROPRIETARY INFORMATION WHICH IS THE CONFIDENTIAL PROPERTY OF AMPHENOL PCD INC. PEABODY, MA		CHKD A. PATRIE 12/4/98		CODE: 58982		SCALE: NONE	SHEET 1 OF 2
			APPD J. CAHALY 12/11/98					

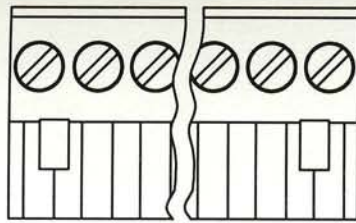

WITHOUT MOUNTING EARS

L=NUM OF POS X CL SPACING

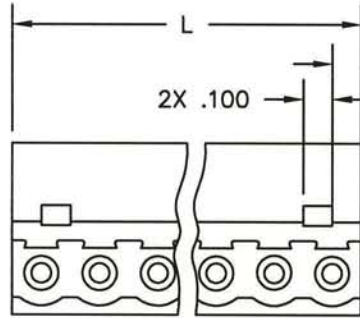

2X .097 (.197 CL)  
.100 (.200 CL)

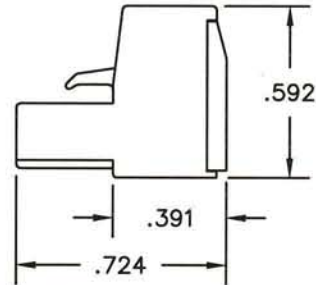

WITH MOUNTING EARS

L=NUM OF POS X CL SPACING

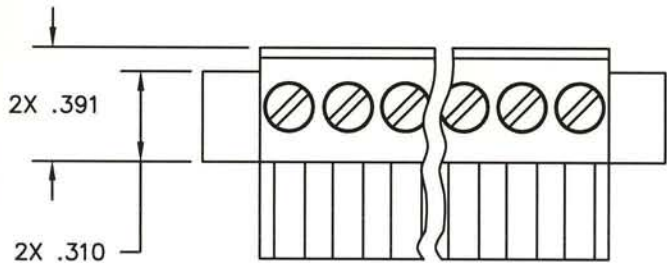

2X .196

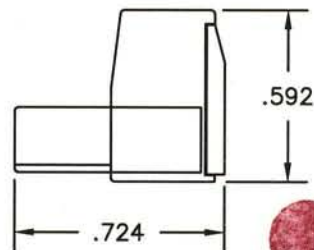
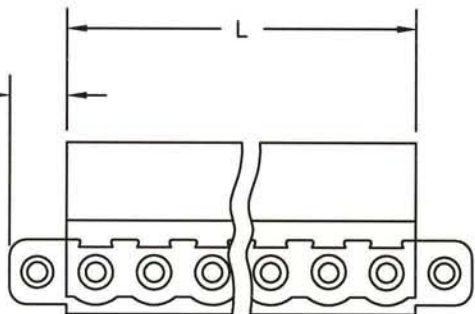

SIZE	DWG NO.	REV
A	ELFP02110	E
CODE: 58982	SCALE: NONE	SHEET 2 OF 2

## X-ON Electronics

Largest Supplier of Electrical and Electronic Components

*Click to view similar products for [Pluggable Terminal Blocks](#) category:*

*Click to view products by [Amphenol](#) manufacturer:*

Other Similar products are found below :

[57.404.7553](#) [57.504.0053.7](#) [57.510.0053](#) [57.910.6153](#) [01.112.1453](#) [CTB932VE/6](#) [MC 1.5/ 6-ST-3.5 GY AU](#) [ET02015000J0G](#) [734-104](#) [734-302](#) [734-304](#) [8-141-P](#) [FKCT 2.5/ 3-ST KMGY](#) [860505](#) [860508](#) [860516](#) [860810](#) [861908](#) [GBPACX-12](#) [93.731.4953.0](#) [PV05-5,08-K](#) [PVP02-5,00](#) [PVP04-3,50](#) [PVS02-5,00](#) [1-1986160-3](#) [H-10](#) [ELFH09150](#) [ELFH16150](#) [ELFP03110](#) [ELFT06250](#) [ELFT07250](#) [ELVF09400](#) [ELVP03100](#) [ELXH03100](#) [ELXH071G0E](#) [ELXP041G0](#) [ELXT046G0](#) [1700101](#) [1700410](#) [1700425](#) [1703176](#) [1703243](#) [1705229](#) [1710175](#) [1714537](#) [1717806](#) [1719600](#) [1729386](#) [1734692](#) [1734795](#)