

AMPHENOL PART NUMBER CONFIGURATION
 UE86-3G2620-X0X61

LIGHT PIPE OPTION

- 0 - NO LIGHT PIPE
- 1 - 4 LP PER 2X1, NORMAL ORIENTATION
- 2 - 2 INNER LP PER 2X1, NORMAL ORIENTATION
- 3 - 2 OUTER LP PER 2X1, NORMAL ORIENTATION
- 4 - 4 LP PER 2X1, REVERSING ORIENTATION
- 5 - 2 INNER LP PER 2X1, REVERSING ORIENTATION
- 6 - 2 OUTER LP PER 2X1, REVERSING ORIENTATION
- 7 - 3 LP PER 2X1, 2 OUTER LP, NORMAL ORIENTATION
- 8 - 3 LP PER 2X1, 2 OUTER LP, REVERSING ORIENTATION

PACKAGING

- 1 - TRAY PACKAGING (STACKED)

PLATING OPTIONS FOR CONNECTOR

- 2 - 30µ" GOLD PLATING ON MATING AREA
15~100µ" MATTE TIN ON TERMINATION
- 3 - 30µ" GOLD PLATING ON MATING AREA
150~300µ" MATTE TIN ON TERMINATION
- 5 - 15µ" GOLD PLATING ON MATING AREA
15~100µ" MATTE TIN ON TERMINATION
- 6 - 15µ" GOLD PLATING ON MATING AREA
150~300µ" MATTE TIN ON TERMINATION

PART NUMBER (LAST DIGIT INDICATING PACKAGING TYPE, NOT PRINTED ON THE PART)
 DATE CODE

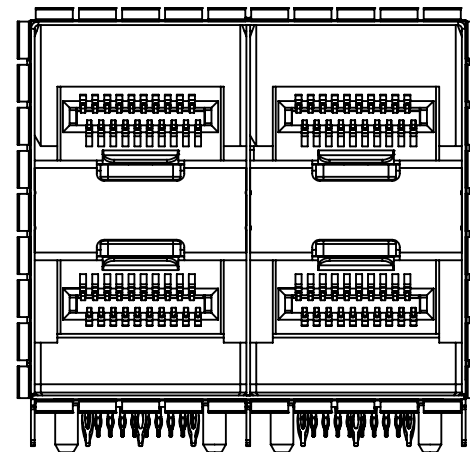
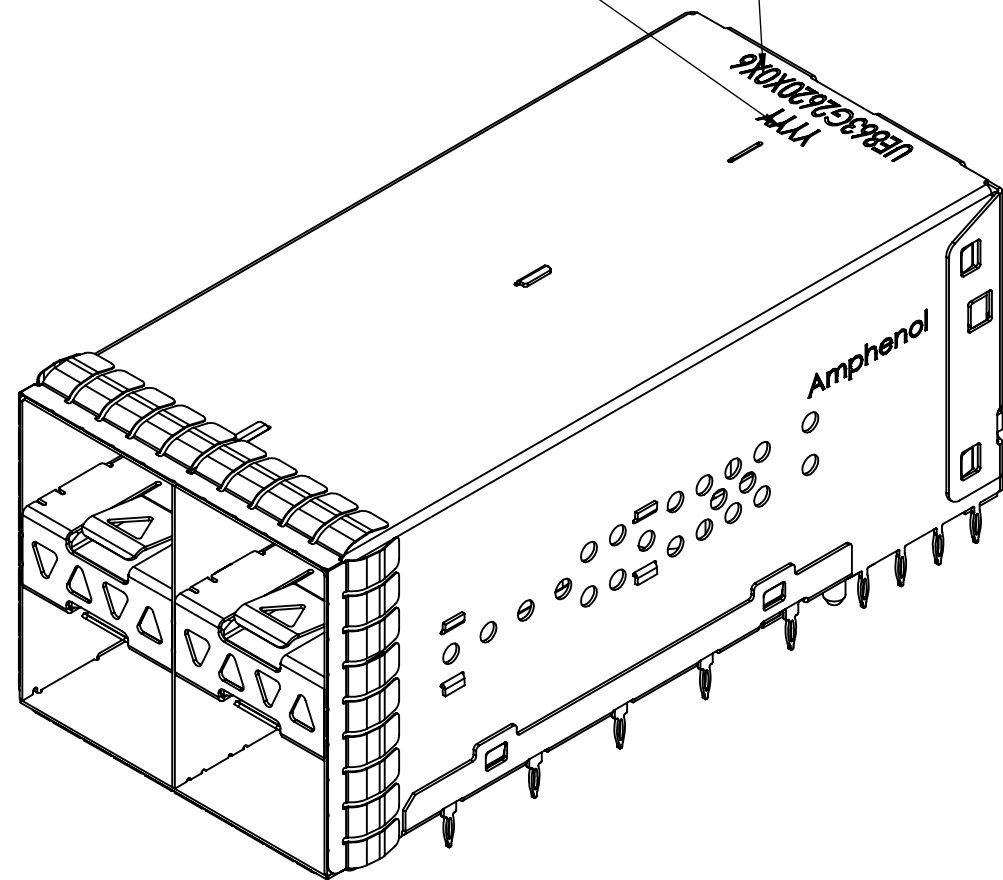

NO LIGHT PIPES
 UE86-3G2620-00X61

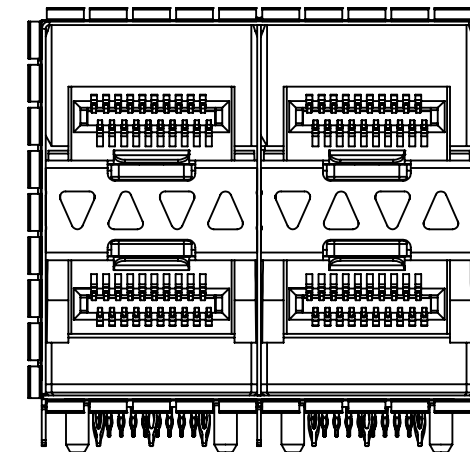

4 LIGHT PIPES
 UE86-3G2620-10X61

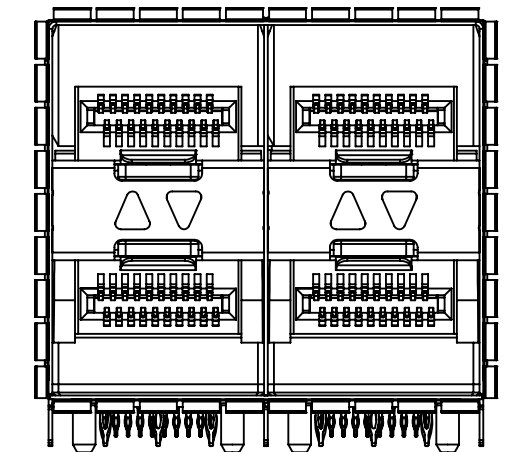

2 INNER LIGHT PIPES
 UE86-3G2620-20X61

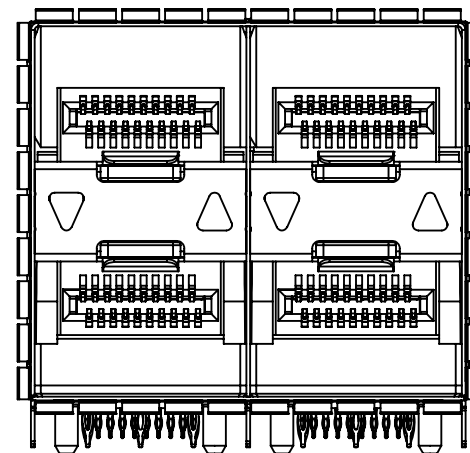

2 OUTER LIGHT PIPES
 UE86-3G2620-30X61

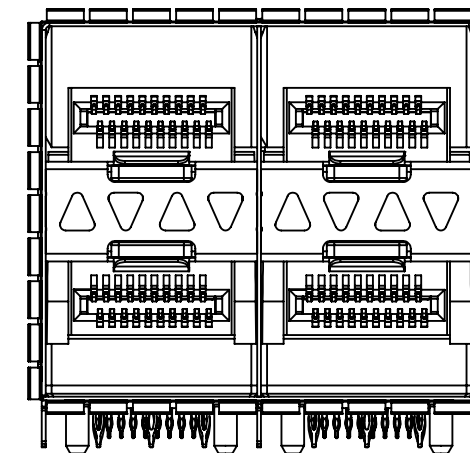

4 LIGHT PIPES UPSIDE DOWN
 UE86-3G2620-40X61

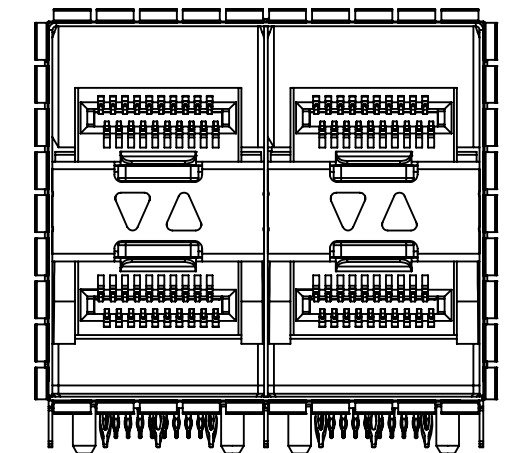

2 INNER LIGHT PIPES UPSIDE DOWN
 UE86-3G2620-50X61

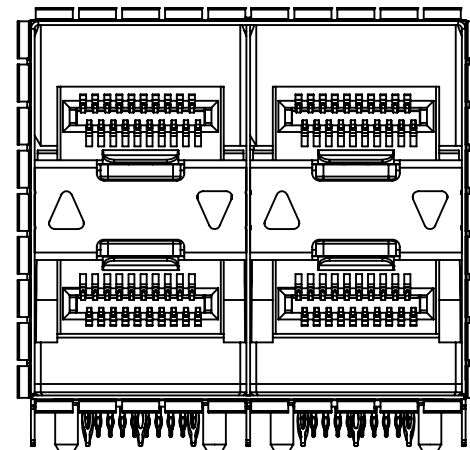

2 OUTER LIGHT PIPES UPSIDE DOWN
 UE86-3G2620-60X61

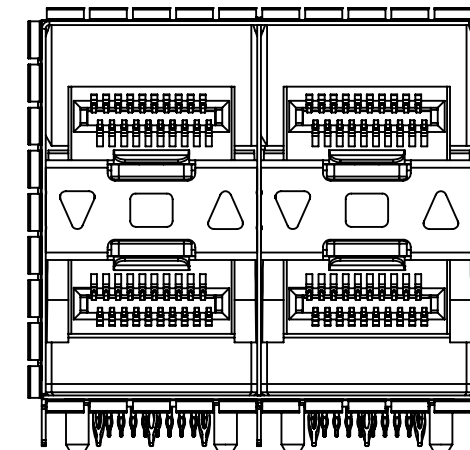

3 LIGHT PIPES
 UE86-3G2620-70X61

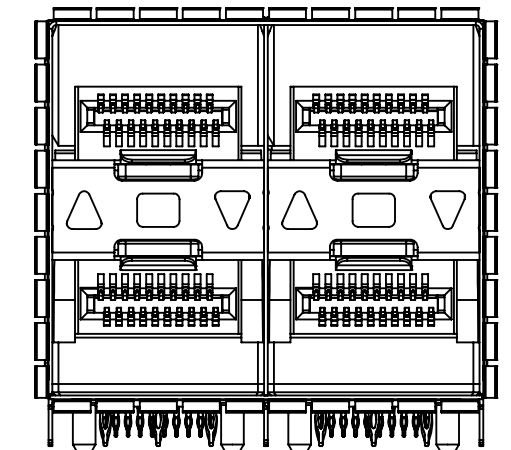

3 LIGHT PIPES UPSIDE DOWN
 UE86-3G2620-80X61

MATERIAL: (RoHS COMPLIANT)

1. CAGE - PRESS FIT: COPPER ALLOY (NICKEL SILVER)
2. CONNECTOR - PRESS FIT:
 -PLASTIC HOUSING: LCP, FLAMMABILITY RATING UL94-V0.
 -CONTACTS: PHOSPHOR BRONZE
3. LIGHT PIPE: CLEAR POLYCARBONATE, FLAMMABILITY RATING UL94-V0.
4. PACKAGING: TRAY PACKAGING.
5. TEMPERATURE RANGE: -40°C TO +85°C



REVISIONS				
REV.	ECN	DESCRIPTION	DATE	APPROVED
C		UPDATE NOTES	AUG 15/14	J.SI
D		CHANGED PCB THICKNESS	NOV 03/15	J.SI
E		REMOVED DIM. ZONE C2, SHEET 2 OF 4	OCT 31/16	J.SI

THIS DOCUMENT CONTAINS PROPRIETARY INFORMATION AND SUCH INFORMATION MAY NOT BE DISCLOSED TO OTHERS FOR ANY PURPOSE OR USED FOR MANUFACTURING PURPOSES WITHOUT WRITTEN PERMISSION FROM AMPHENOL CANADA CORP.

UNLESS SPECIFIED OTHERWISE DIMENSIONS ARE IN MILLIMETERS	DRAWN	P. OU	FEB10/14	Amphenol High Speed Interconnects A Division of Amphenol Corp. www.amphenolcanada.com
REFERENCE IN PARENTHESES	CHECKED	J. SI	NOV03/15	
GENERAL TOLERANCES	M.E. APP'D			2X2 SFP ULTRAPORT WITH LIGHT PIPE OPTIONS AND EMI SPRING FINGER
1 DECIMAL PLACE ±0.25	Q.A. APP'D			
2 DECIMAL PLACE ±0.15	DWG APP'D	J. SI	NOV03/15	REV E
3 DECIMAL PLACE ±0.10	MATERIAL AND FINISH	SEE NOTES		
ANGULAR DEGREES ±1°	REF.	ECN Exxxxx	DWG. NO.	P-UE86-3G2620-X0X61
ENG. REL. NO.	THIRD ANGLE PROJECTION	DO NOT SCALE DRAWING	CODE ID NO. 03554	DWG SIZE: C
			SCALE: 2:1	SHEET 1 OF 4

REVISIONS				
REV.	ECN	DESCRIPTION	DATE	APPROVED
C		UPDATE NOTES	AUG 15/14	J.SI
D		CHANGED PCB THICKNESS	NOV 03/15	J.SI
E		REMOVED DIM. ZONE C2, SHEET 2 OF 4	OCT 31/16	J.SI

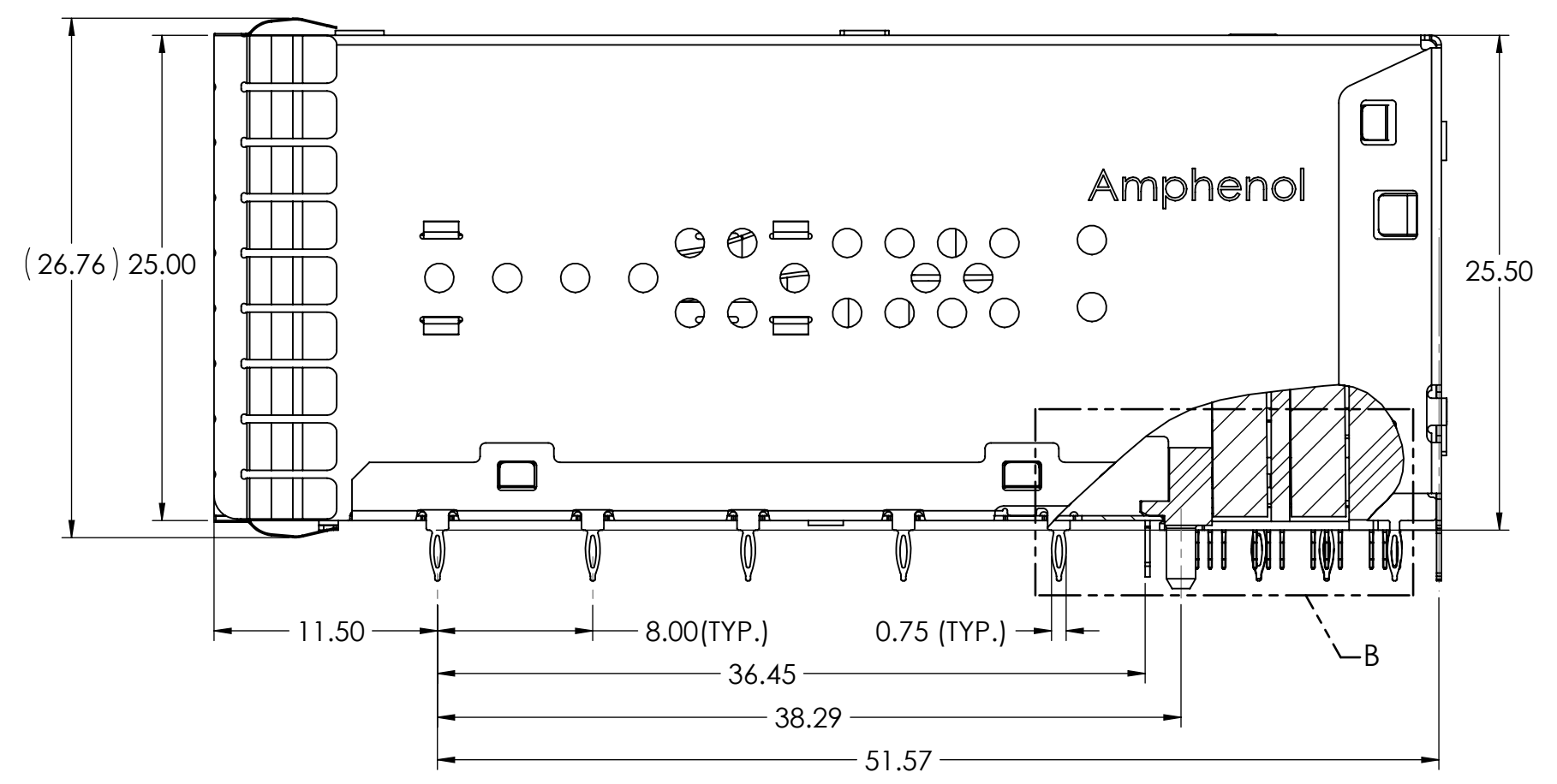
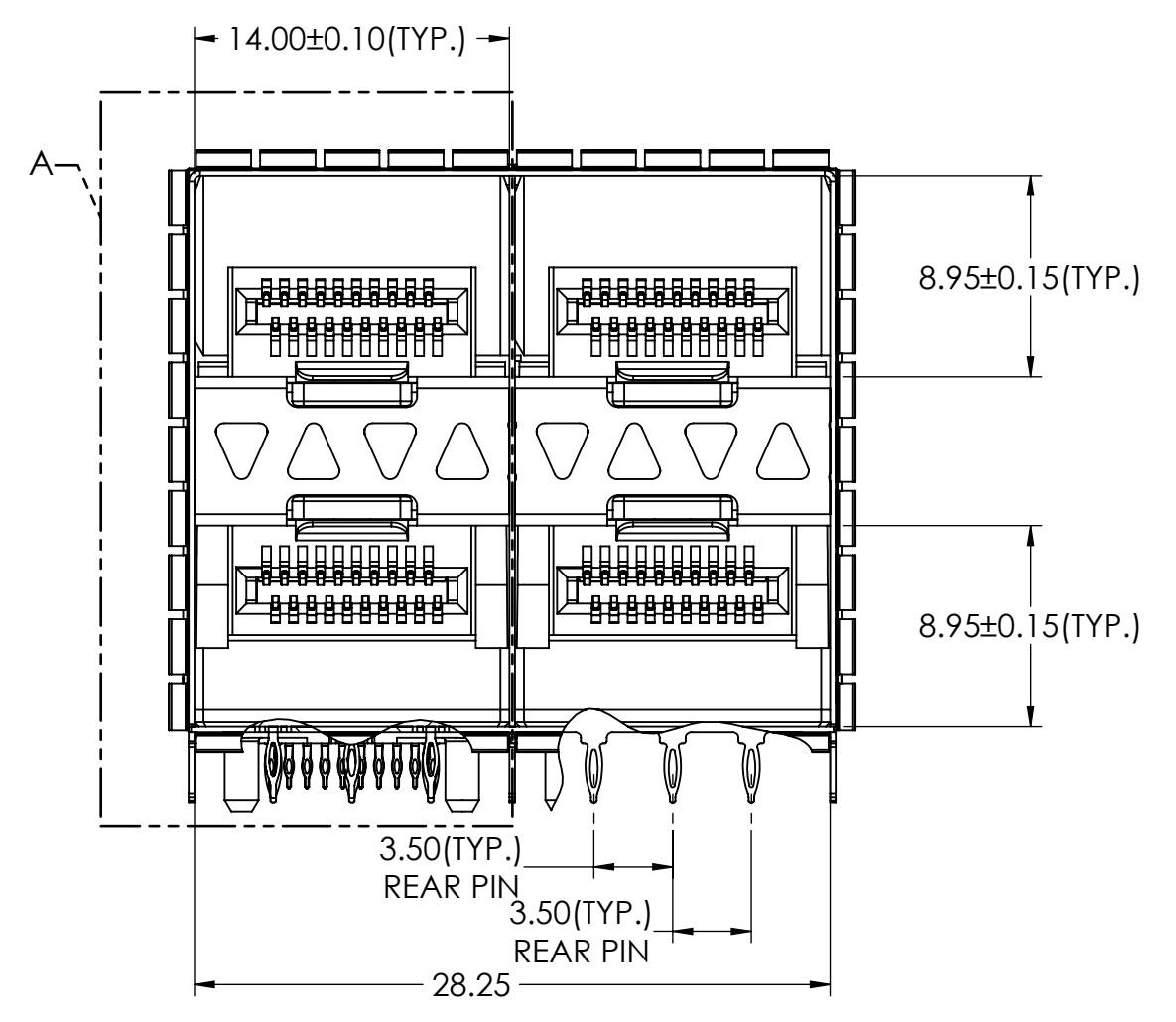
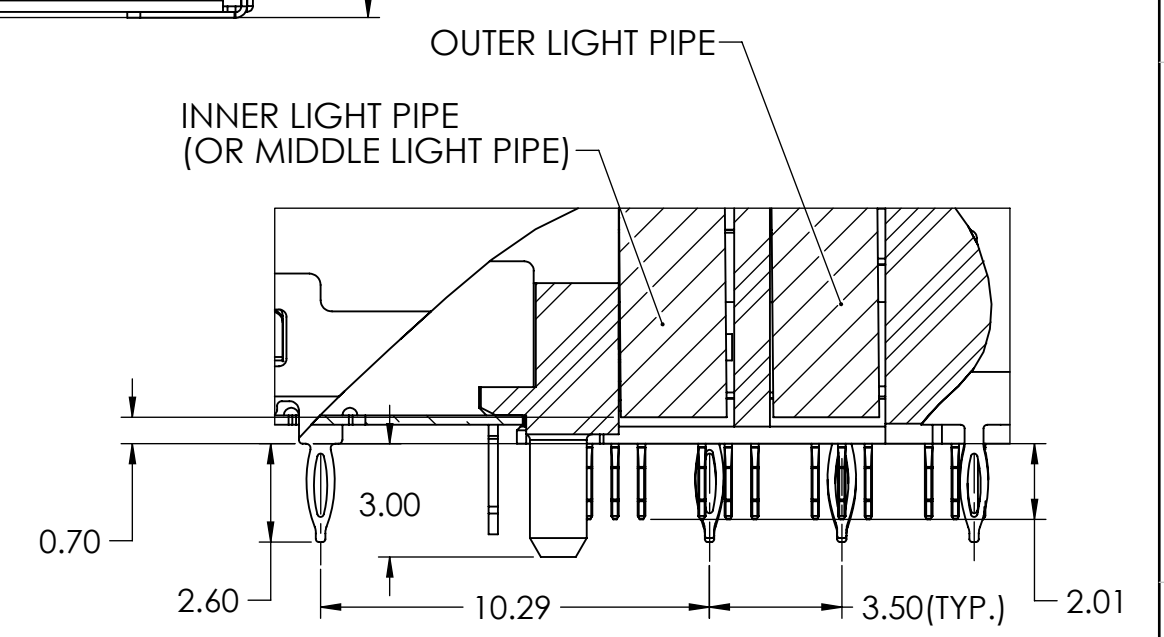
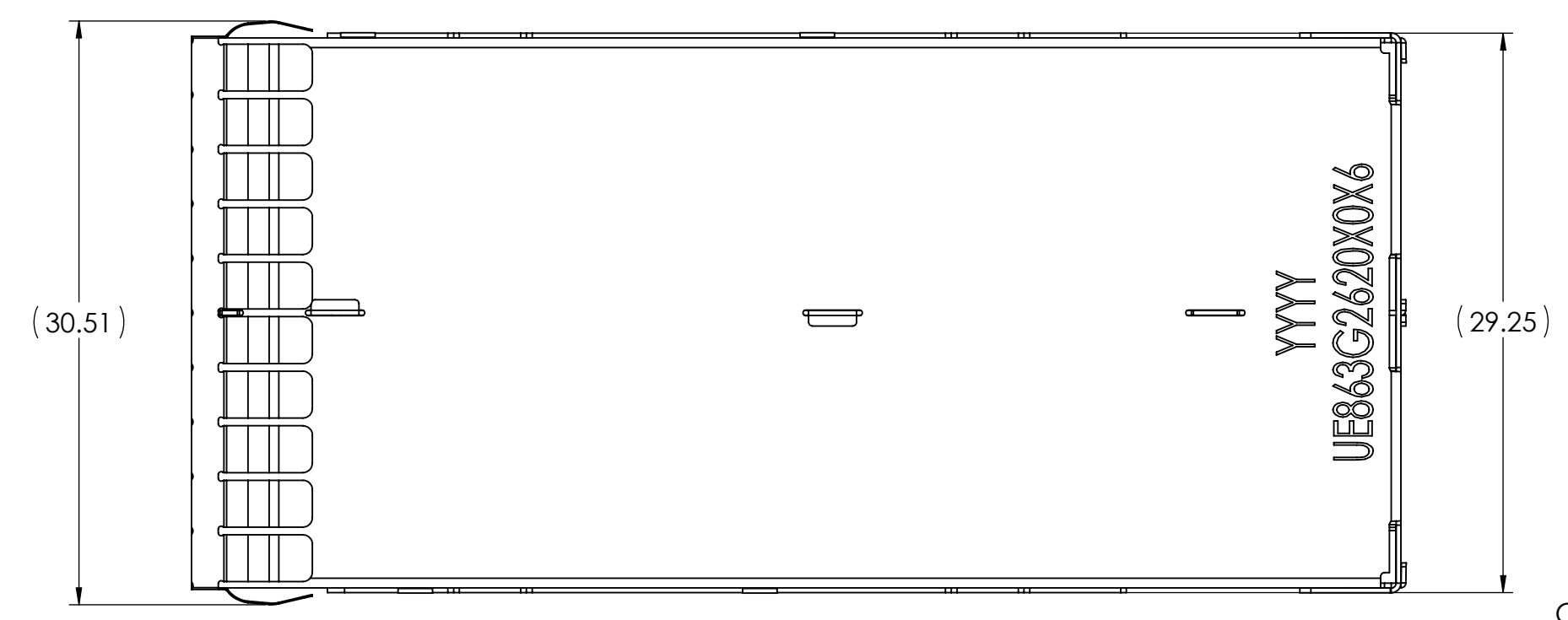
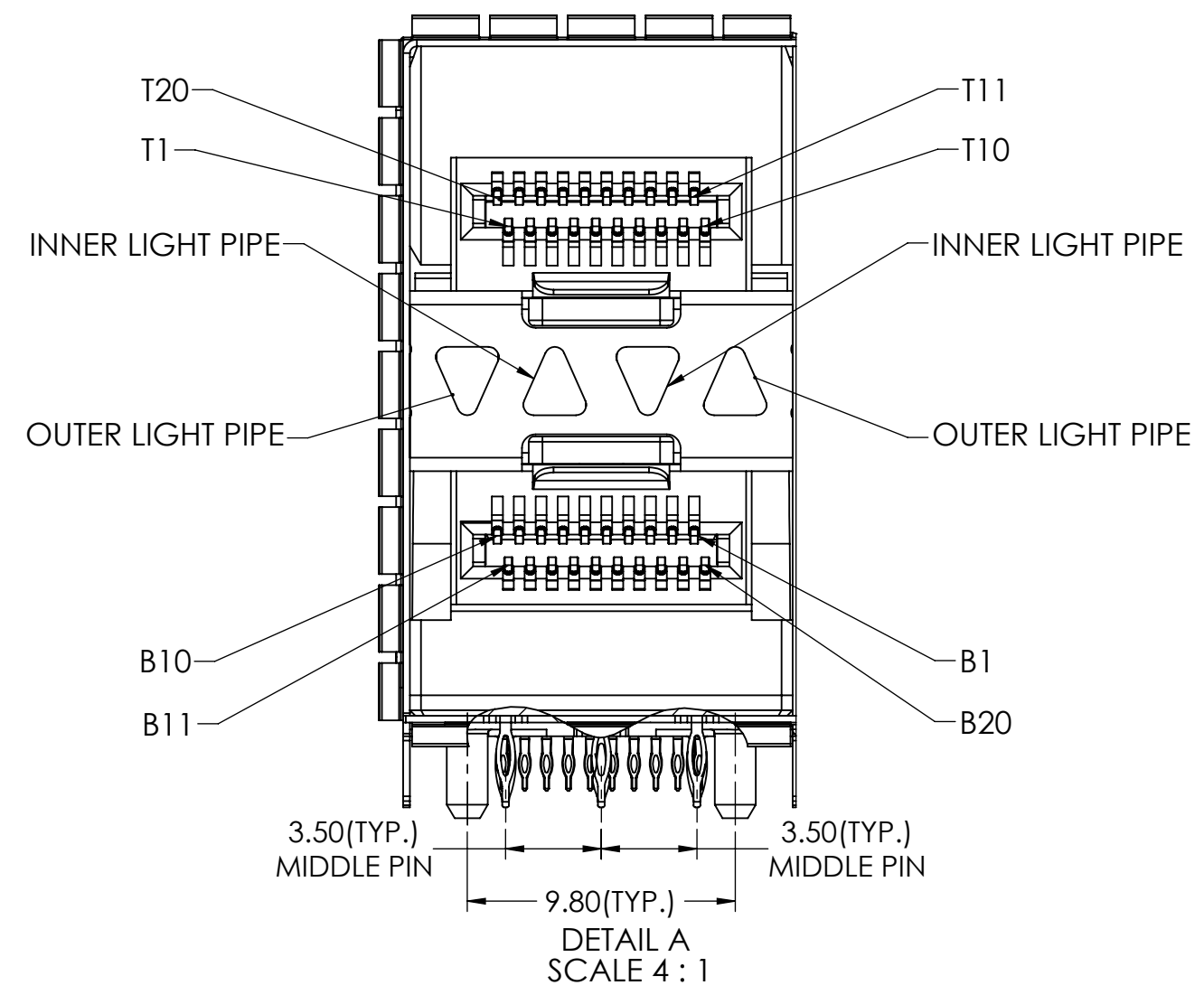

UNLESS SPECIFIED OTHERWISE DIMENSIONS ARE IN MILLIMETERS REFERENCE IN PARENTHESES	DRAWN P. OU CHECKED J. SI M.E. APP'D Q.A. APP'D	FEB10/14 NOV03/15	Amphenol High Speed Interconnects A Division of Amphenol Corp. www.amphenolcanada.com
GENERAL TOLERANCES 1 DECIMAL PLACE ±0.25 2 DECIMAL PLACE ±0.15 3 DECIMAL PLACE ±0.10 ANGULAR DEGREES ±1°	DWG APP'D J. SI MATERIAL AND FINISH SEE NOTES REF. ECN Exxxxx	NOV03/15	
ENG. REL. NO.	THIRD ANGLE PROJECTION	DO NOT SCALE DRAWING	DWG. NO. P-UE86-3G2620-X0X61
THIS DOCUMENT CONTAINS PROPRIETARY INFORMATION AND SUCH INFORMATION MAY NOT BE DISCLOSED TO OTHERS FOR ANY PURPOSE OR USED FOR MANUFACTURING PURPOSES WITHOUT WRITTEN PERMISSION FROM AMPHENOL CANADA CORP.		CODE ID NO. 03554	DWG SIZE: C SCALE: 3:1 SHEET 2 OF 4

THIS DOCUMENT CONTAINS PROPRIETARY INFORMATION AND SUCH INFORMATION MAY NOT BE DISCLOSED TO OTHERS FOR ANY PURPOSE OR USED FOR MANUFACTURING PURPOSES WITHOUT WRITTEN PERMISSION FROM AMPHENOL CANADA CORP.

REVISIONS				
REV.	ECN	DESCRIPTION	DATE	APPROVED
C		UPDATE NOTES	AUG 15/14	J.SI
D		CHANGED PCB THICKNESS	NOV 03/15	J.SI
E		REMOVED DIM. ZONE C2, SHEET 2 OF 4	OCT 31/16	J.SI

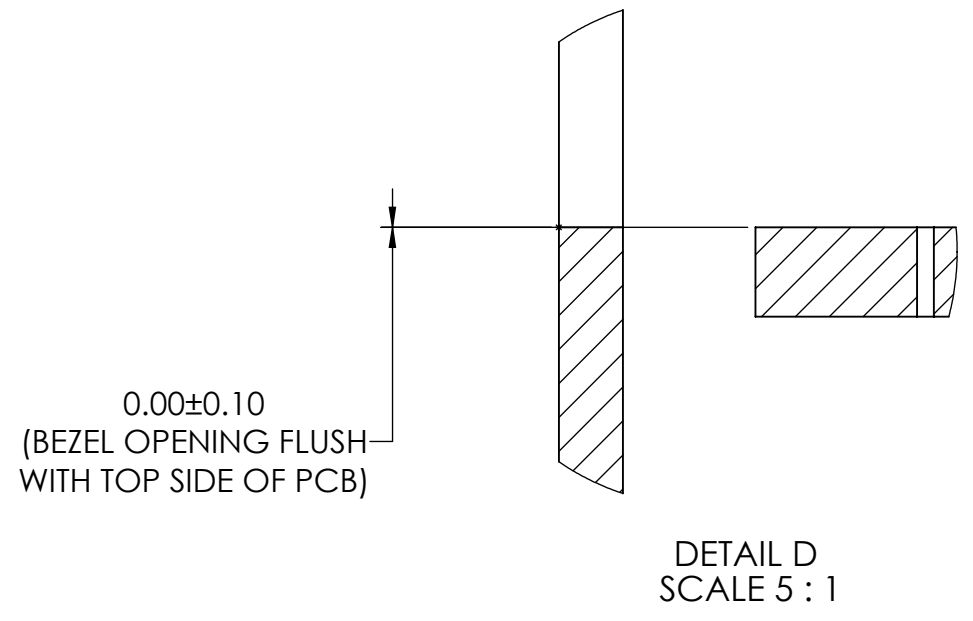
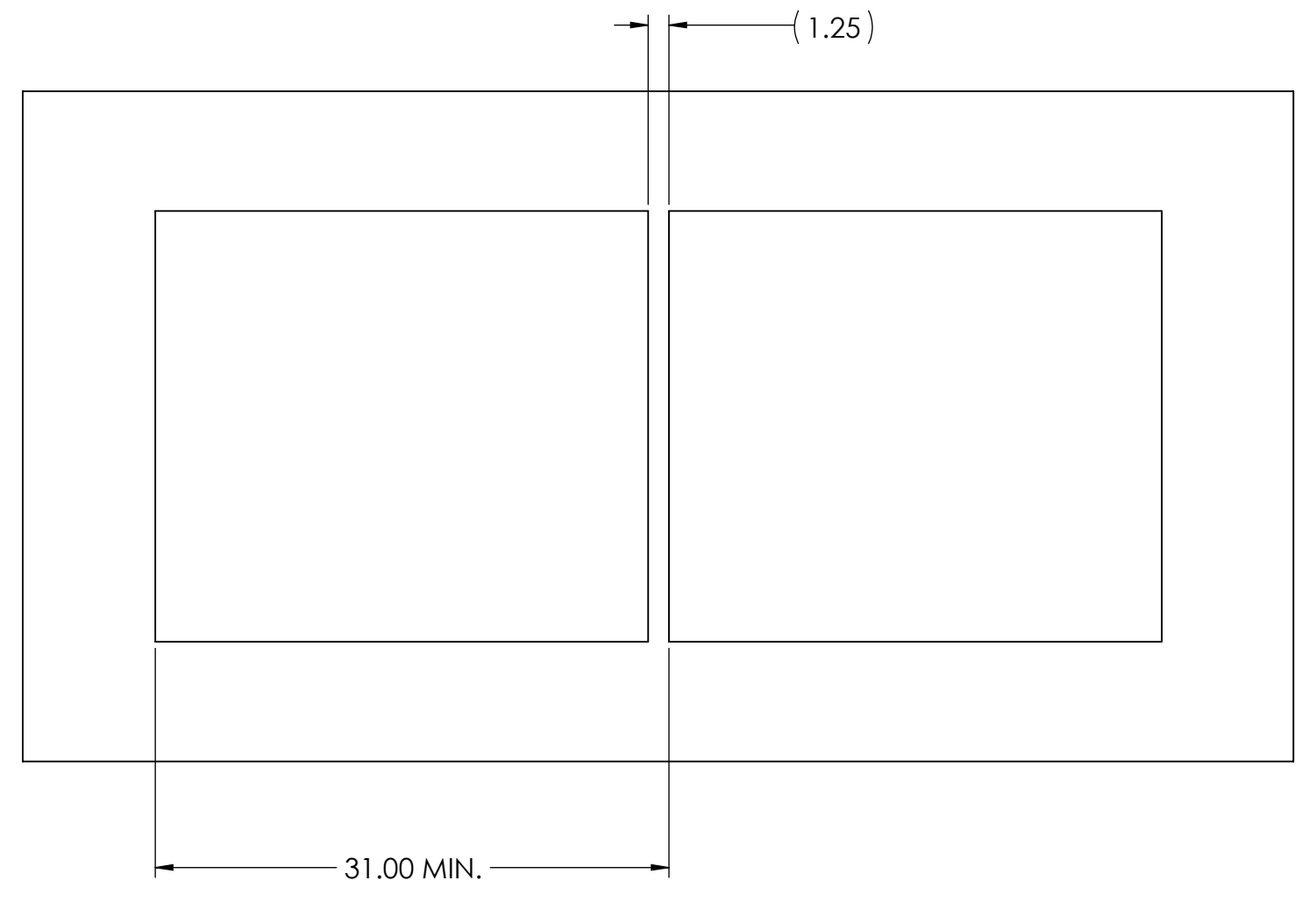
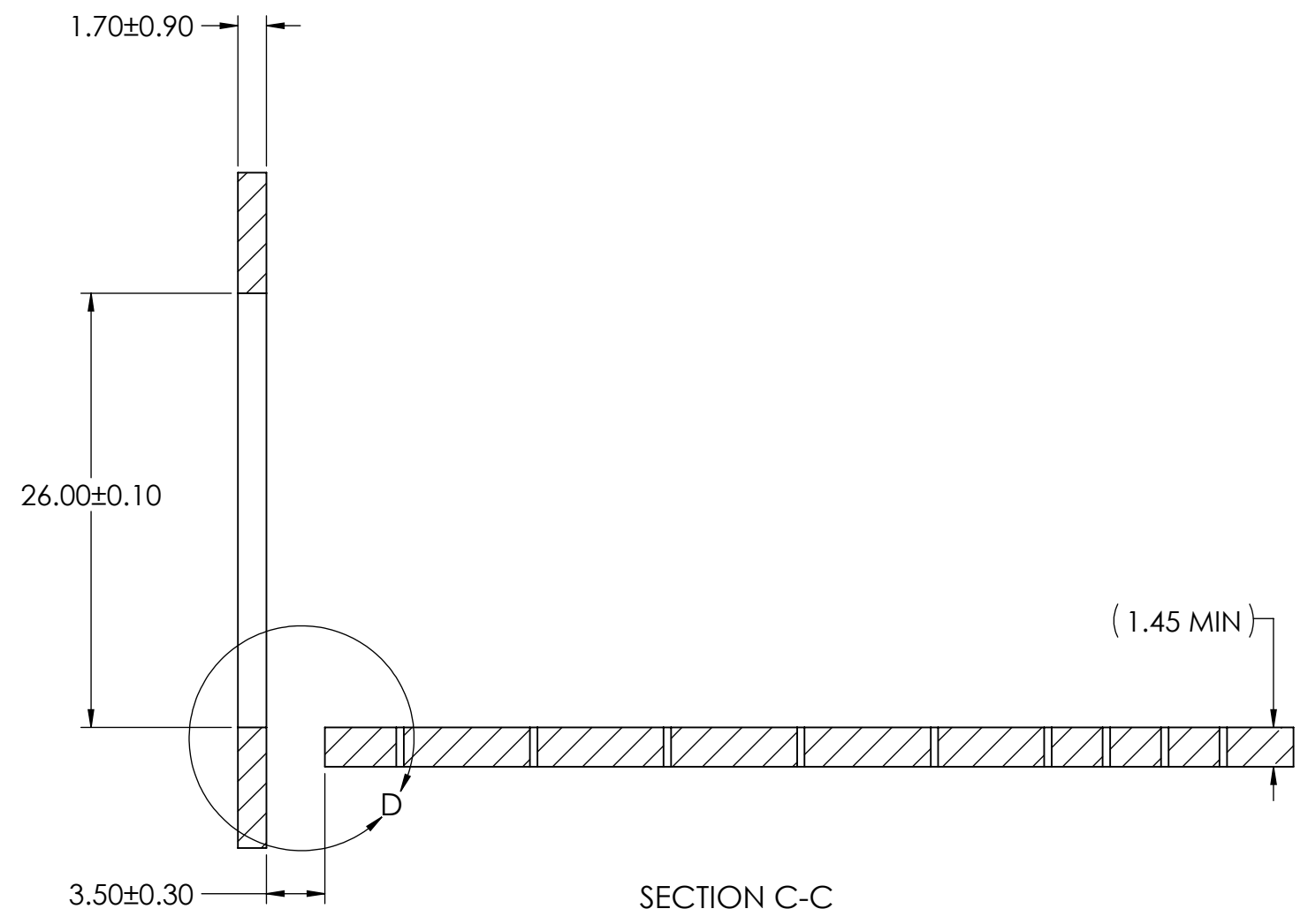
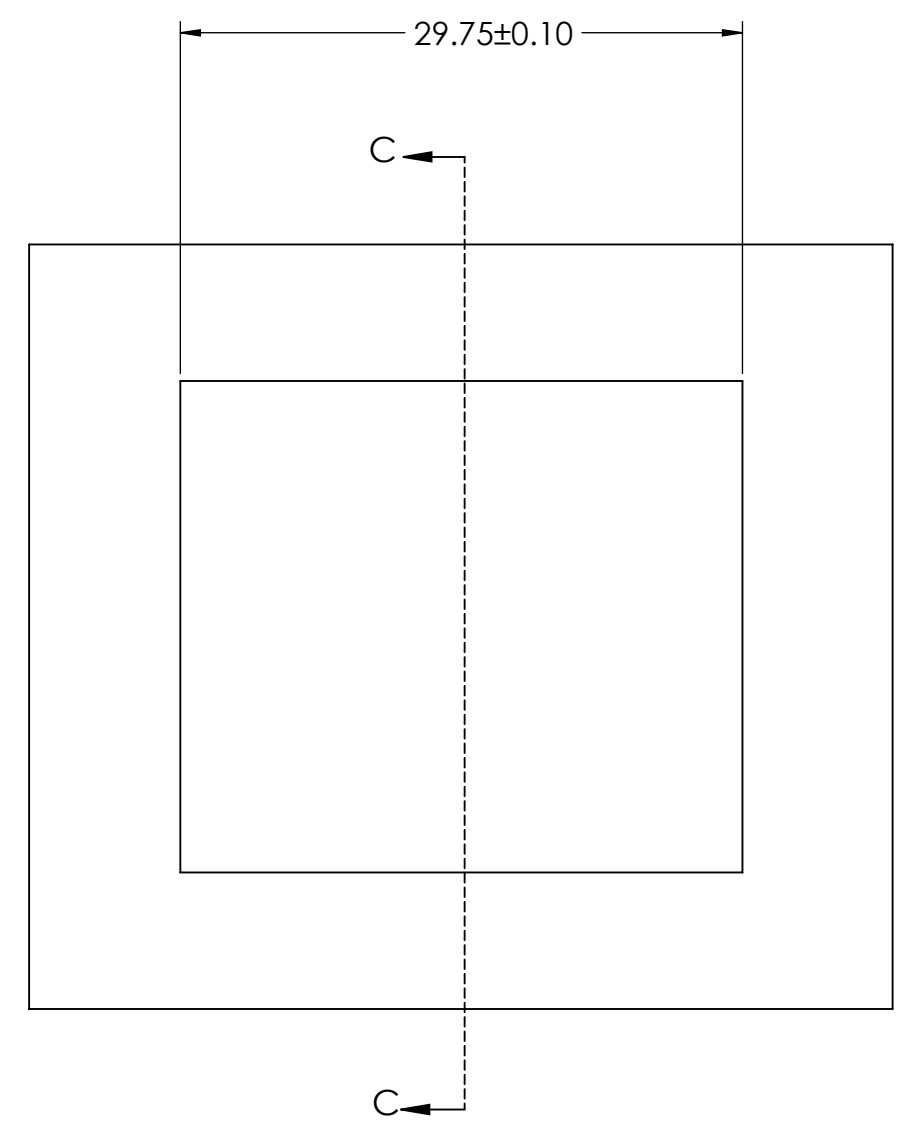

THIS DOCUMENT CONTAINS PROPRIETARY INFORMATION AND SUCH INFORMATION MAY NOT BE DISCLOSED TO OTHERS FOR ANY PURPOSE OR USED FOR MANUFACTURING PURPOSES WITHOUT WRITTEN PERMISSION FROM AMPHENOL CANADA CORP.

UNLESS SPECIFIED OTHERWISE	DRAWN	P. OU	FEB10/14	Amphenol High Speed Interconnects A Division of Amphenol Corp. www.amphenolcanada.com
DIMENSIONS ARE IN MILLIMETERS	CHECKED	J. SI	NOV03/15	
REFERENCE IN PARENTHESES	M.E. APP'D			
GENERAL TOLERANCES	Q.A. APP'D			2X2 SFP ULTRAPORT WITH LIGHT PIPE OPTIONS AND EMI SPRING FINGER
1 DECIMAL PLACE ±0.25	DWG APP'D	J. SI	NOV03/15	
2 DECIMAL PLACE ±0.15	MATERIAL AND FINISH	SEE NOTES		
3 DECIMAL PLACE ±0.10	REF.	ECN Exxxxx		DWG. NO.
ANGULAR DEGREES ±1°	THIRD ANGLE PROJECTION	DO NOT SCALE DRAWING		P-UE86-3G2620-X0X61
ENG. REL. NO.				CODE ID NO. 03554 DWG SIZE: C SCALE: 2.5:1 SHEET 3 OF 4

REV E

REVISIONS				
REV.	ECN	DESCRIPTION	DATE	APPROVED
C		UPDATE NOTES	AUG 15/14	J.SI
D		CHANGED PCB THICKNESS	NOV 03/15	J.SI
E		REMOVED DIM. ZONE C2, SHEET 2 OF 4	OCT 31/16	J.SI

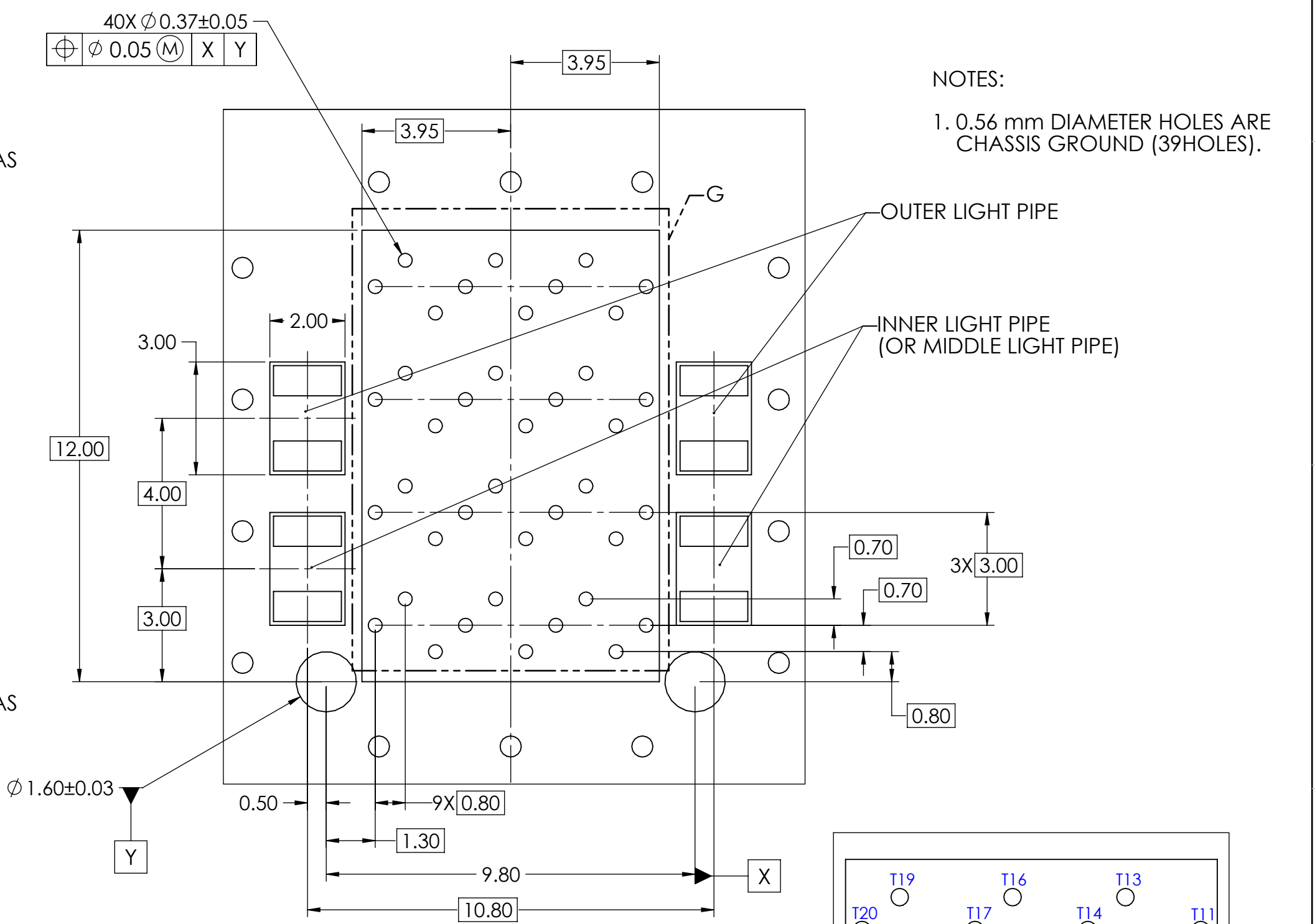
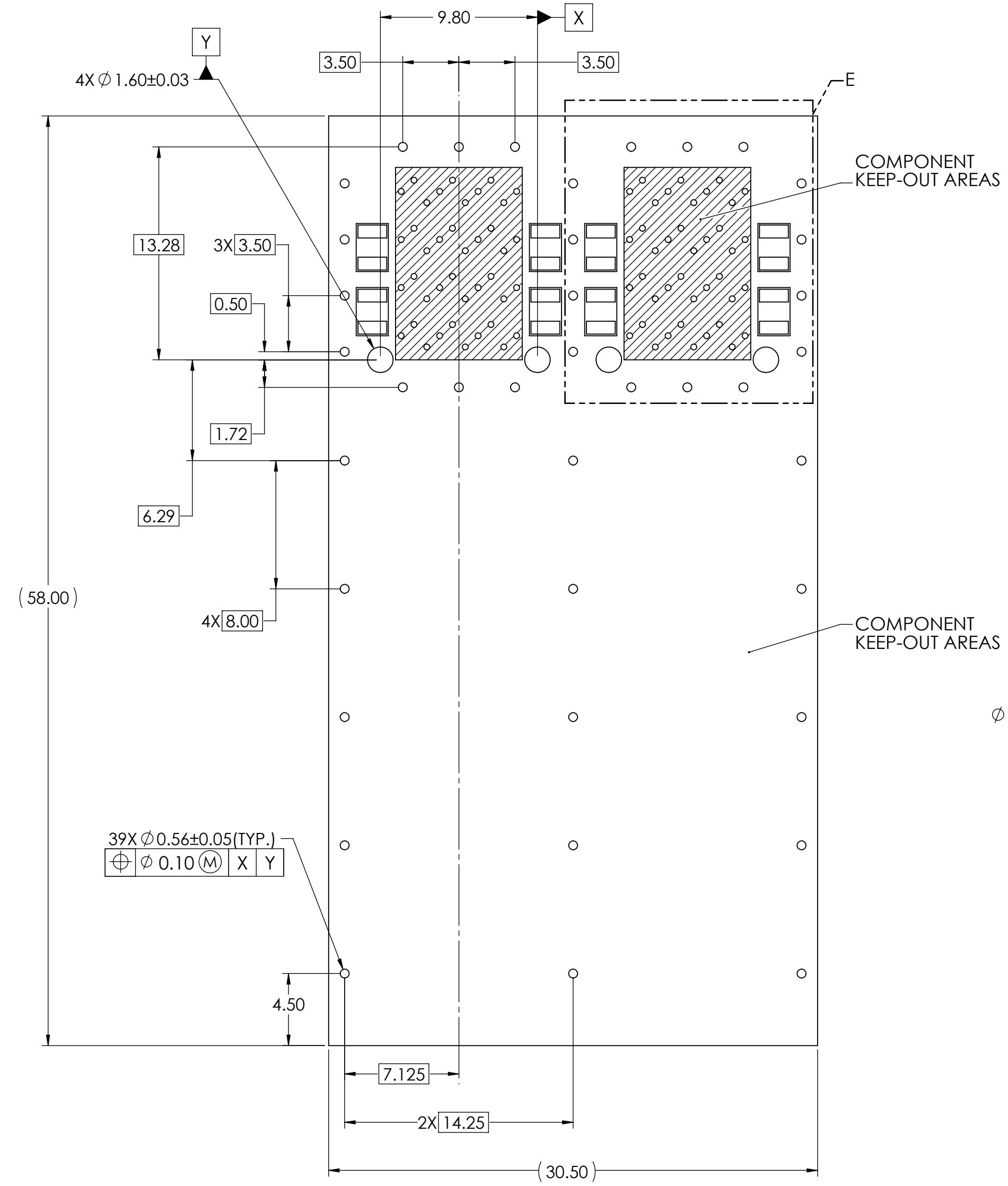

NOTES:
1. 0.56 mm DIAMETER HOLES ARE CHASSIS GROUND (39HOLES).

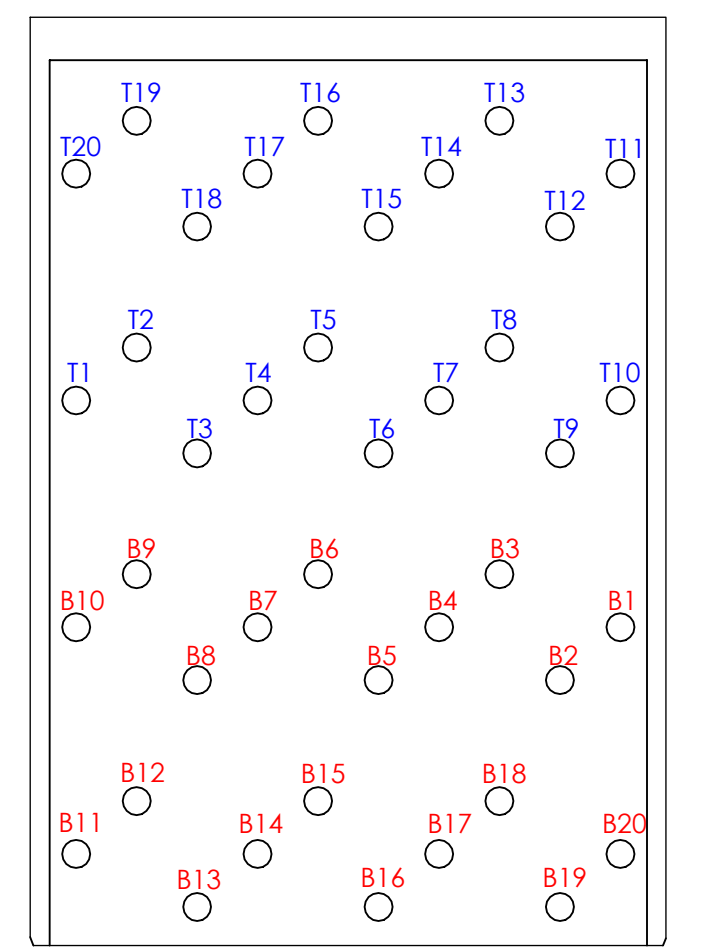

THIS DOCUMENT CONTAINS PROPRIETARY INFORMATION AND SUCH INFORMATION MAY NOT BE DISCLOSED TO OTHERS FOR ANY PURPOSE OR USED FOR MANUFACTURING PURPOSES WITHOUT WRITTEN PERMISSION FROM AMPHENOL CANADA CORP.

UNLESS SPECIFIED OTHERWISE	DRAWN	P. OU	FEB10/14	Amphenol High Speed Interconnects A Division of Amphenol Corp. www.amphenolcanada.com
DIMENSIONS ARE IN MILLIMETERS	CHECKED	J. SI	NOV03/15	
REFERENCE IN PARENTHESES	M.E. APP'D			2X2 SFP ULTRAPORT WITH LIGHT PIPE OPTIONS AND EMI SPRING FINGER
GENERAL TOLERANCES	Q.A. APP'D			
1 DECIMAL PLACE ± 0.25	DWG APP'D	J. SI	NOV03/15	REV E
2 DECIMAL PLACE ± 0.15	MATERIAL AND FINISH	SEE NOTES		
3 DECIMAL PLACE ± 0.10	REF.	ECN Exxxxx	DWG. NO.	P-UE86-3G2620-X0X61
ANGULAR DEGREES $\pm 1^\circ$	THIRD ANGLE PROJECTION	DO NOT SCALE DRAWING	CODE ID NO. 03554	
ENG. REL. NO.			DWG SIZE: C	SCALE: 4:1
				SHEET 4 OF 4

X-ON Electronics

Largest Supplier of Electrical and Electronic Components

Click to view similar products for [I/O Connectors](#) category:

Click to view products by [Amphenol](#) manufacturer:

Other Similar products are found below :

[571763P](#) [58098-0628](#) [72.250.1628.2](#) [72.250.2428.2](#) [74720-0505](#) [76.350.0729.0](#) [76871-1403](#) [FCN-244F080-G/1](#) [FCN-260A9920](#) [PCR-E36PM](#) [PCS-XE26MA+](#) [G38A71314B](#) [1571250010](#) [157-22500-3](#) [MS3471L14-19P L/C](#) [192991-0703](#) [172501-4002](#) [172501-6002](#) [FCN-260C008-A/L0](#) [FCN-260C024-AL0](#) [FCN-261Z008](#) [2000314-1](#) [200331-1](#) [PCR-E36FC+](#) [PCS-E28FS+](#) [PCS-XE26SLFD+](#) [PCS-XE26SLFDT+](#) [G730VID08BDC24](#) [HDR-E14MSG1+](#) [U90B2054081210](#) [UE86K842720321](#) [38113800006](#) [DP3AR020WQ1R200](#) [Z4.102.0680.0](#) [500-1040](#) [500-1052](#) [500-1054](#) [ZP-4008-66L](#) [0709821002](#) [DX40-20P\(55\)](#) [5554841-1](#) [MS3474W18-8P-LC*](#) [SM3106F14S-7S-LC](#) [U90B3054061110](#) [U65-E04-4020](#) [ZPF000000000097891](#) [557-262M2-06C](#) [747360449](#) [10099439-003C-TRLF](#) [10137239-0021LF](#)