

# ORIGINAL

This document is the property of Amphenol Corporation and is delivered on the express condition that is not to be disclosed, reproduced or used, in whole or in part, for manufacture or sale by anyone other than Amphenol Corporation without its prior consent, and that no right is granted to disclose or to use any information in this document.

The marking on this product doesn't contain environmental hazardous materials per Material Specification SS-00259 for Sony GP compliant or per directive 2011/65/EU for RoHS compliant.

REVISIONS				
SYM	ECN No.	DESCRIPTION	DATE	BY
A	NE-14070	NEW RELEASE	04/28/2014	HANK HSU
B	NE-14176	ADDED COLOR DESCRIPTION IN NOTES	10/02/2014	HANK HSU

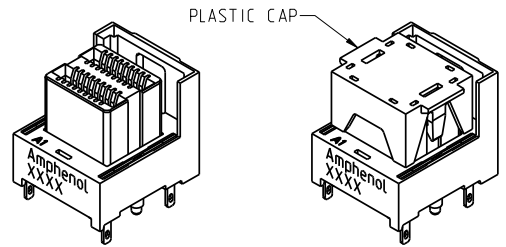
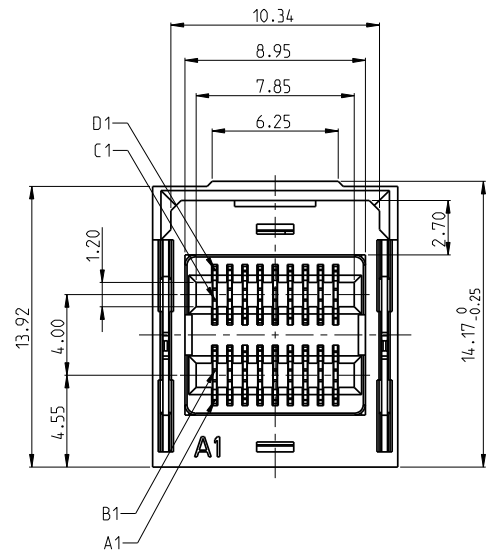
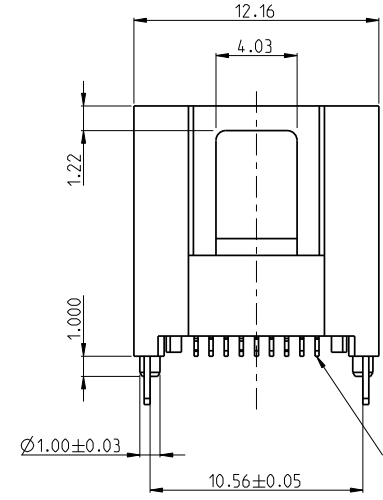
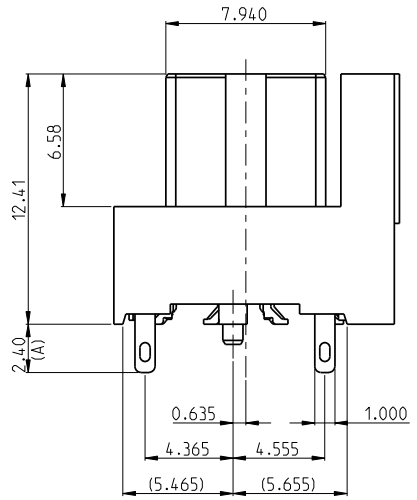
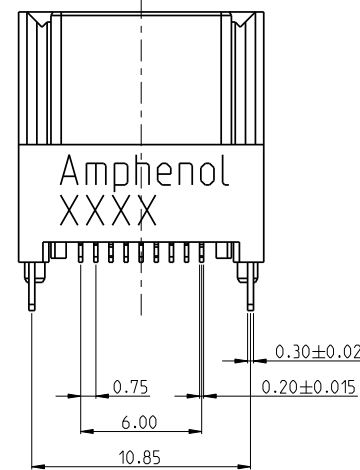
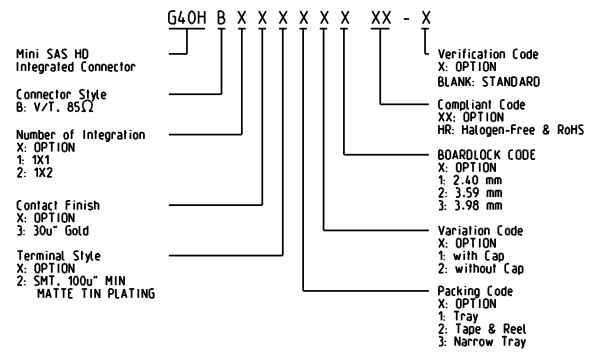

TABLE 1

DIM A	APPLICABLE PCB THK
2.40	1.57~1.60
3.59	2.36~2.79
3.98	3.18

### PART NUMBER SYSTEM



- NOTES:
- INSULATOR: HIGH TEMPERATURE UL94V-0, COLOR: NC(BRACKET), BK(HOUSING)
  - TERMINAL: COPPER ALLOYBRASS  
CONTACT AREA: OPTION  
SOLDERING AREA: OPTION  
UNDER PLTING.: Ni 100u" MIN.
  - THIS PRODUCT DOESN'T CONTAIN ENVIRONMENTAL HAZARDOUS PER DIRECTIVE 2011/65/EU FOR RoHS AND PER IEC 61249-2-21 FOR HALOGEN-FREE COMPLIANT.

TOLERANCE	DRAWN	APPROVALS	DATE	TITLE	Amphenol® Amphenol Corporation Amphenol Taiwan Corporation					
X. X.X ±0.30 X.XX ±0.20 X.XXX ±0.10	DESIGNED	Hank Hsu	10/02/2014	MINI SAS HD INTEGRATED CONNECTOR 0.75 PITCH, V/T, SMT TYPE	UNIT	mm	SIZE	A3	PART No.	G40HBXXXXXXHR-C
ANGULAR ±2°	CHECKED	Sondra Sang	10/02/2014		SCALE	NA	SHEET	1 OF 3	DWG No.	G40HBXXXXXXHR-C
UNLESS OTHERWISE SPECIFIED	DWG TYPE	CUST DWG	PROJECT CODE	1515					REV.	B

ORIGINAL

REVISIONS				
SYM	ECN No.	DESCRIPTION	DATE	BY
A	NE-14070	NEW RELEASE	04/28/2014	HANK HSU
B	NE-14176	ADDED COLOR DESCRIPTION IN NOTES	10/02/2014	HANK HSU

This document is the property of Amphenol Corporation and is delivered on the express condition that is not to be disclosed, reproduced or used, in whole or in part, for manufacture or sale by anyone other than Amphenol Corporation without its prior consent, and that no right is granted to disclose or to use any information in this document.

The marking on this product doesn't contain environmental hazardous materials per Material Specification SS-00259 for Sony GP compliant or per directive 2011/65/EU for RoHS compliant.

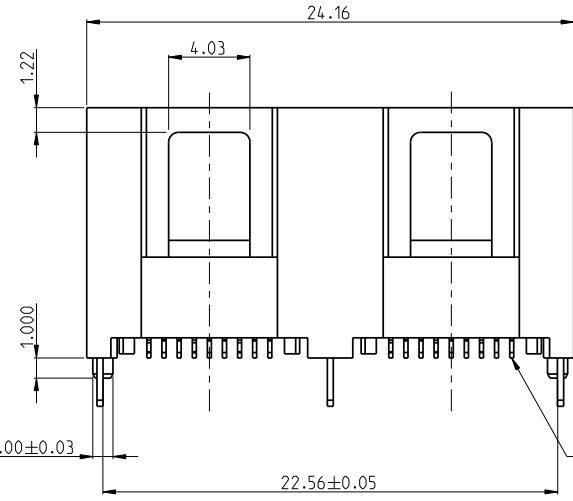
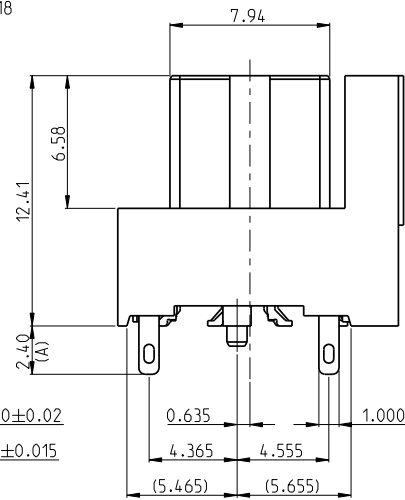
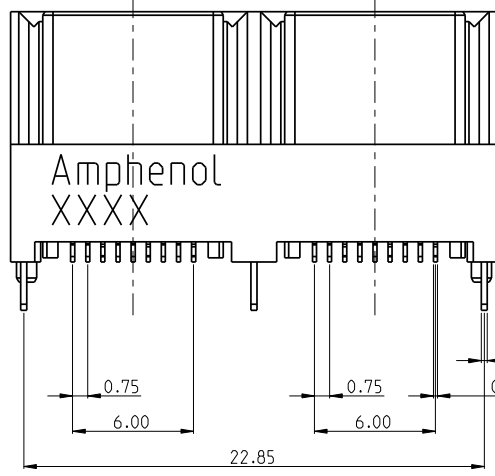
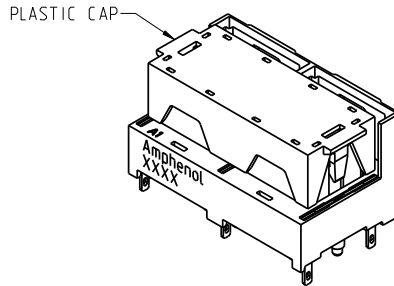
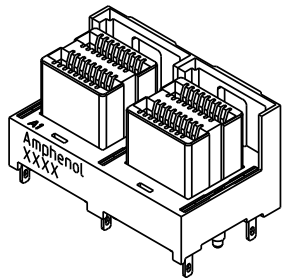
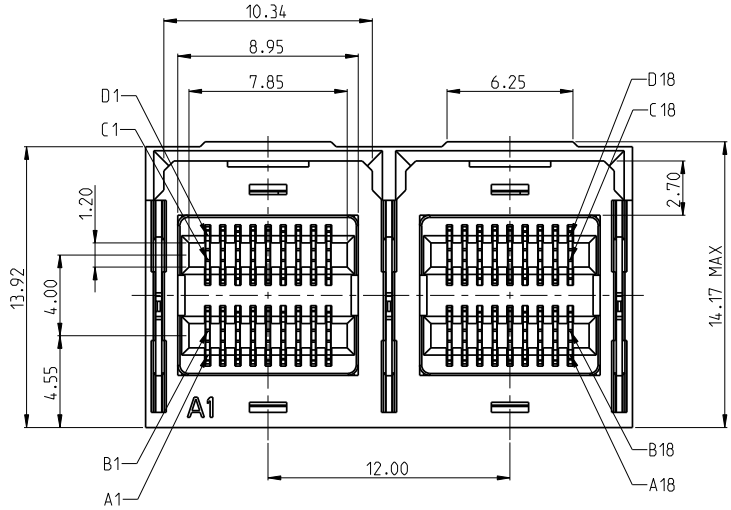

0.10 ALL SMT TAILS

TOLERANCE	DRAWN	APPROVALS	DATE	TITLE	Amphenol® Amphenol Corporation Amphenol Taiwan Corporation			
X. ±0.30	DESIGNED	Hank Hsu	10/02/2014	MINI SAS HD INTEGRATED CONNECTOR 0.75 PITCH, V/T, SMT TYPE	UNIT	SIZE	PART No.	G40HBXXXXXXHR-C
X.X ±0.20	CHECKED	Sondra Sang	10/02/2014		mm	A3	G40HBXXXXXXHR-C	
X.XX ±0.10	APPROVED	Hank Hsu	10/02/2014		SCALE	SHEET		
ANGULAR ±2°	DWG TYPE	CUST DWG	PROJECT CODE	1515	NA	2 OF 3	G40HBXXXXXXHR-C	B
UNLESS OTHERWISE SPECIFIED								

ORIGINAL

REVISIONS				
SYM	ECN No.	DESCRIPTION	DATE	BY
A	NE-14070	NEW RELEASE	04/28/2014	HANK HSU
B	NE-14176	ADDED COLOR DESCRIPTION IN NOTES	10/02/2014	HANK HSU

This document is the property of Amphenol Corporation and is delivered on the express condition that is not to be disclosed, reproduced or used, in whole or in part, for manufacture or sale by anyone other than Amphenol Corporation without its prior consent, and that no right is granted to disclose or to use any information in this document.

The marking on this product doesn't contain environmental hazardous materials per Material Specification SS-00259 for Sony GP compliant or per directive 2011/65/EU for RoHS compliant.

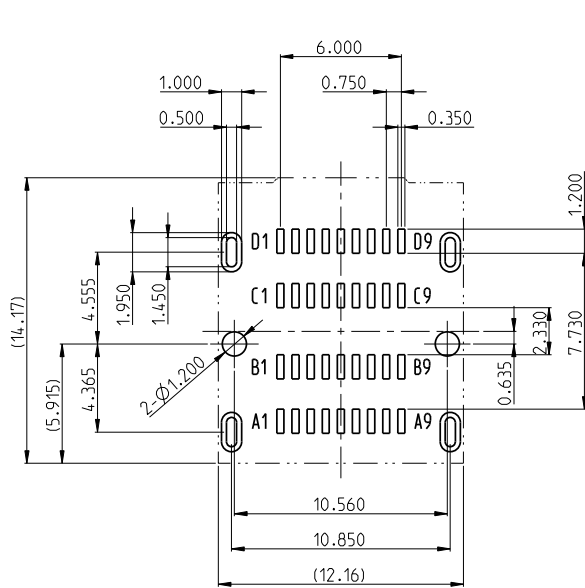

1X1 RECOMMENDED PCB LAYOUT  
(ALL TOLERANCES ARE ±0.05)

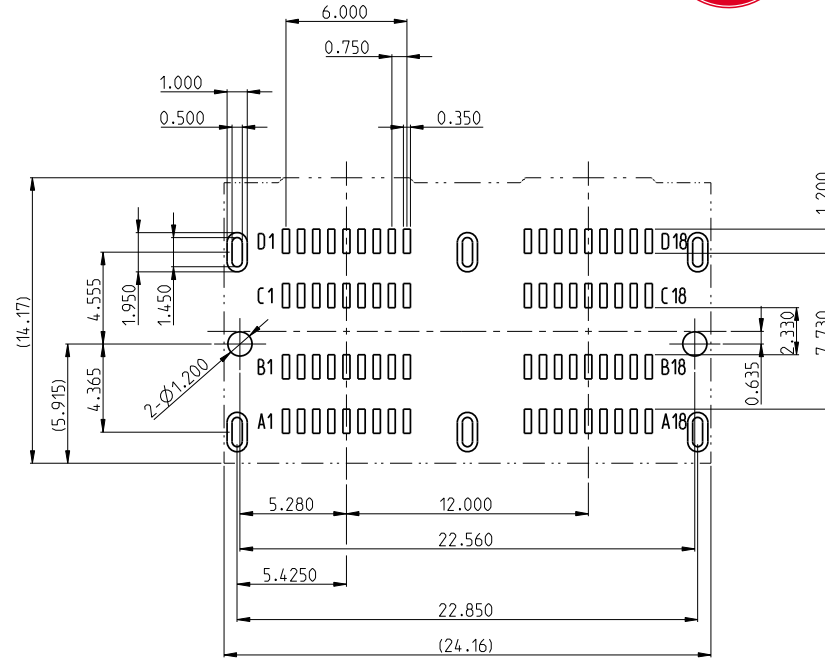

1X2 RECOMMENDED PCB LAYOUT  
(ALL TOLERANCES ARE ±0.05)

NOTES:

1. RECOMMENDED PCB HOLE Ø1.20 IS NPTH FOR ORIENTATION POST.
2. RECOMMENDED PCB ELLIPTICAL HOLE 0.5X1.45 IS PTH FOR BOARD-LOCK.
3. MINIMUM PCB THICKNESS: 1.57MM
4. PIN ASSIGNMENTS PLEASE REFER TO SERIAL ATTACHED SCSI-3 (SAS-3) STANDARD.

TOLERANCE	DRAWN APPROVALS	DATE	TITLE	UNIT		SIZE	PART No.
X.	DESIGNED <b>Hank Hsu</b>	10/02/2014	MINI SAS HD INTEGRATED CONNECTOR 0.75 PITCH, V/T, SMT TYPE	mm	A3	G40HBXXXXXHR-C	
X.X ±0.30	CHECKED <b>Sondra Sang</b>	10/02/2014					
X.XX ±0.20	APPROVED <b>Hank Hsu</b>	10/02/2014					
X.XXX ±0.10	DWG TYPE <b>CUST DWG</b>	PROJECT CODE <b>1515</b>		SCALE <b>NA</b>	SHEET <b>3 OF 3</b>	DWG No. <b>G40HBXXXXXHR-C</b>	REV. <b>B</b>
ANGULAR ±2°	UNLESS OTHERWISE SPECIFIED						

Amphenol®

Amphenol Corporation  
Amphenol Taiwan Corporation

## X-ON Electronics

Largest Supplier of Electrical and Electronic Components

*Click to view similar products for [I/O Connectors](#) category:*

*Click to view products by [Amphenol](#) manufacturer:*

Other Similar products are found below :

[571763P](#) [58098-0628](#) [72.250.1628.2](#) [72.250.2428.2](#) [74720-0505](#) [76.350.0729.0](#) [76871-1403](#) [FCN-244F080-G/1](#) [FCN-260A9920](#) [MP-5T180MUNNA-005](#) [PCR-E36PM](#) [PCS-XE26MA+](#) [G38A71314B](#) [1571250010](#) [157-22500-3](#) [MS3471L14-19P L/C](#) [192991-0703](#) [172501-4002](#) [172501-6002](#) [FCN-260C008-A/L0](#) [FCN-260C024-AL0](#) [FCN-261Z008](#) [2000314-1](#) [200331-1](#) [PCR-E36FC+](#) [PCS-E28FS+](#) [PCS-XE26SLFD+](#) [PCS-XE26SLFDT+](#) [G730VID08BDC24](#) [HDR-E14MSG1+](#) [U90B2054081210](#) [UE86K842720321](#) [38113800006](#)  
[DP3AR020WQ1R200](#) [Z4.102.0680.0](#) [500-1040](#) [500-1052](#) [500-1054](#) [ZP-4008-66L](#) [0709821002](#) [DX40-20P\(55\)](#) [5554841-1](#) [MS3474W18-8P-LC\\*](#) [SM3106F14S-7S-LC](#) [U90B3054061110](#) [U65-E04-4020](#) [ZPF000000000097891](#) [557-262M2-06C](#) [747360449](#) [10099439-003C-TRLF](#)