

This document is the property of Amphenol Corporation and is delivered on the express condition that it is not to be disclosed, reproduced or used, in whole or in part, for manufacture or sale by anyone other than Amphenol Corporation without its prior consent, and that no right is granted to disclose or to use any information in this document.

The marking on this product doesn't contain environmental hazardous material and must follow one or more specifications per Material Specification SS-00259 for Sony GP compliant or per directive 2002/95/EC for RoHS compliant or per IEC 61249-2-21 for Halogen Free compliant.

REVISIONS				
SYM	ECN No.	DESCRIPTION	DATE	BY
A	NE-12016	RELEASE TO PRODUCTION	02/03/2012	Chenny Yeh

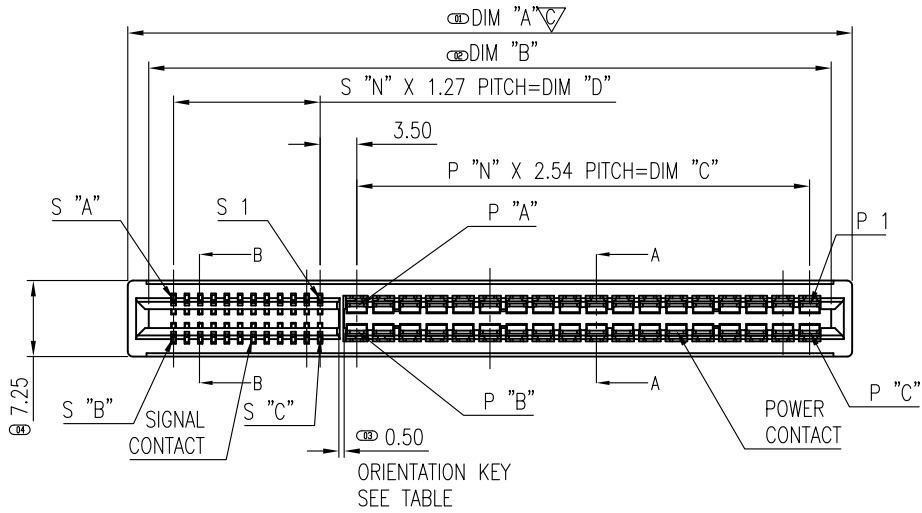

P/N SYSTEM:
GPCE 3 X X X X X 1 X HR

CONTACT FINISH:
0: GOLD FLASH
1: 5u" GOLD
2: 10u" GOLD
3: 15u" GOLD
4: 30u" GOLD

POWER PIN Q'TY:
08: 8 PIN
36: 36 PIN
48: 48 PIN
56: 56 PIN

VARIATION CODE:
BLANK: STANDARD
1: WITHOUT ORIENTATION KEY

SIGNAL PIN Q'TY:
12: 12 PIN
20: 20 PIN
24: 24 PIN

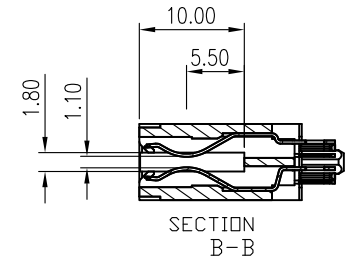
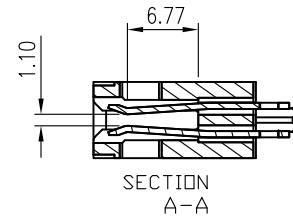
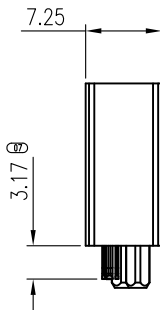
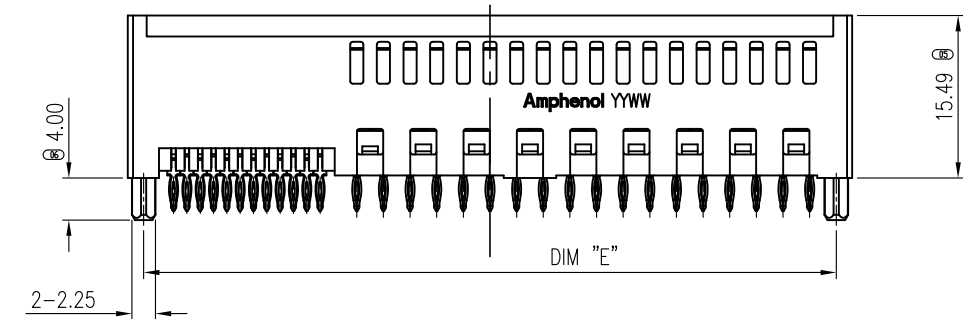

NOTES:

- MATERIAL:**
HOUSING: HIGH TEMPERATURE THERMO PLASTIC UL94V-0 COLOR BLACK
TERMINAL: HIGH PERFORMANCE COPPER ALLOY
- FINISH:**
TERMINAL:
CONTACT AREA: SELECTIVE GOLD PL.
SOLDERING AREA: MATT TIN PL. 120 μ" THK MIN.
UNDER PL.: NICKEL PL. 50 μ" THK MIN.
- THIS PRODUCT DOESN'T CONTAIN ENVIRONMENTAL HAZARDOUS MATERIALS PER DIRECTIVE 2002/95/EC FOR RoHS AND PER IEC 61249-2-21 FOR HALOGEN FREE COMPLIANT.
- THE DIMENSIONS MARKED (NO) WILL BE CHECKED BY Q.C. AND PROCESS ENGINEERS.

TOLERANCE	DRAWN	APPROVALS	DATE	TITLE		PART No.	
X. ±0.30 X.X ±0.20 X.XX ±0.10 X.XXX ±0.10	DESIGNED	Chenny Yeh	2/8/2012	ENERGY EDGE RECEPTACLE,PRESS-FIT TYPE		Amphenol [®] Amphenol Corporation Amphenol Taiwan Corporation	
	CHECKED	Sondra Sang	2/8/2012				
	APPROVED	Hank Hsu	2/8/2012				
ANGULAR ±2°	DWG TYPE	CUST DWG	PROJECT CODE	UNIT	SIZE	PART No.	
UNLESS OTHERWISE SPECIFIED			T521	mm	A3	GPCE3XXXXX1HR	
				SCALE	SHEET	DWG No.	
				NA	1 OF 4	GPCE3X36241HR	
						REV. A	

This document is the property of Amphenol Corporation and is delivered on the express condition that it is not to be disclosed, reproduced or used, in whole or in part, for manufacture or sale by anyone other than Amphenol Corporation without its prior consent, and that no right is granted to disclose or to use any information in this document.

The marking on this product doesn't contain environmental hazardous material and must follow one or more specifications per Material Specification SS-00259 for Sony GP compliant or per directive 2002/95/EC for RoHS compliant or per IEC 61249-2-21 for Halogen Free compliant.

REVISIONS				
SYM	ECN No.	DESCRIPTION	DATE	BY
A	NE-12016	RELEASE TO PRODUCTION	02/03/2012	Chenny Yeh

GPCE3X562411HR	NO	27	11	94.48	90.48	68.58	13.97	91.44	P28	P29	P56	S12	S13	S24
GPCE3X56241HR	YES	27	11	94.48	90.48	68.58	13.97	91.44	P28	P29	P56	S12	S13	S24
GPCE3X481211HR	NO	23	5	76.70	72.70	58.42	6.35	73.66	P24	P25	P48	S6	S7	S12
GPCE3X48121HR	YES	23	5	76.70	72.70	58.42	6.35	73.66	P24	P25	P48	S6	S7	S12
GPCE3X362411HR	NO	17	11	69.08	65.08	43.18	13.97	66.04	P18	P19	P36	S12	S13	S24
GPCE3X36241HR	YES	17	11	69.08	65.08	43.18	13.97	66.04	P18	P19	P36	S12	S13	S24
GPCE3X242411HR	NO	11	11	53.84	49.84	27.94	13.97	50.80	P12	P13	P24	S12	S13	S24
GPCE3X24241HR	YES	11	11	53.84	49.84	27.94	13.97	50.80	P12	P13	P24	S12	S13	S24
GPCE3X162411HR	NO	7	11	43.68	39.68	17.78	13.97	40.64	P8	P9	P16	S12	S13	S24
GPCE3X16241HR	YES	7	11	43.68	39.68	17.78	13.97	40.64	P8	P9	P16	S12	S13	S24
GPCE3X082011HR	NO	3	9	30.98	26.98	7.62	11.43	27.94	P4	P5	P8	S10	S11	S20
GPCE3X08201HR	YES	3	9	30.98	26.98	7.62	11.43	27.94	P4	P5	P8	S10	S11	S20
PART NUMBER	ORIENTATION KEY	P "N"	S "N"	DIM "A"	DIM "B"	DIM "C"	DIM "D"	DIM "E"	P "A"	P "B"	P "C"	S "A"	S "B"	S "C"

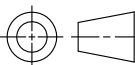
TOLERANCE	DRAWN	APPROVALS	DATE	TITLE				UNIT	SIZE	PART No.	Amphenol [®] Amphenol Corporation Amphenol Taiwan Corporation	
X. X.X ±0.30 X.XX ±0.20 X.XXX ±0.10	DESIGNED	Chenny Yeh	2/8/2012	ENERGY EDGE RECEPTACLE,PRESS-FIT TYPE	mm	A3		GPCE3XXXXX1HR				
ANGULAR ±2°	CHECKED	Sondra Sang	2/8/2012		SCALE	SHEET		DWG No.				
UNLESS OTHERWISE SPECIFIED	APPROVED	Hank Hsu	2/8/2012		NA	2 OF 4		GPCE3X36241HR	REV. A			
	DWG TYPE	CUST DWG	PROJECT CODE									
			T521									

on the express condition that it is not to be disclosed, reproduced or used, in whole or in part, for manufacture or sale by anyone other than Amphenol Corporation without its prior consent, and that no right is granted to disclose or to use any information in this document.

The marking on this product doesn't contain environmental hazardous material and must follow one or more specifications per Material Specification SS-00259 for Sony GP compliant or per directive 2002/95/EC for RoHS compliant or per IEC 61249-2-21 for Halogen Free compliant.

REVISIONS				
SYM	ECN No.	DESCRIPTION	DATE	BY
A	NE-12016	RELEASE TO PRODUCTION	02/03/2012	Chenny Yeh

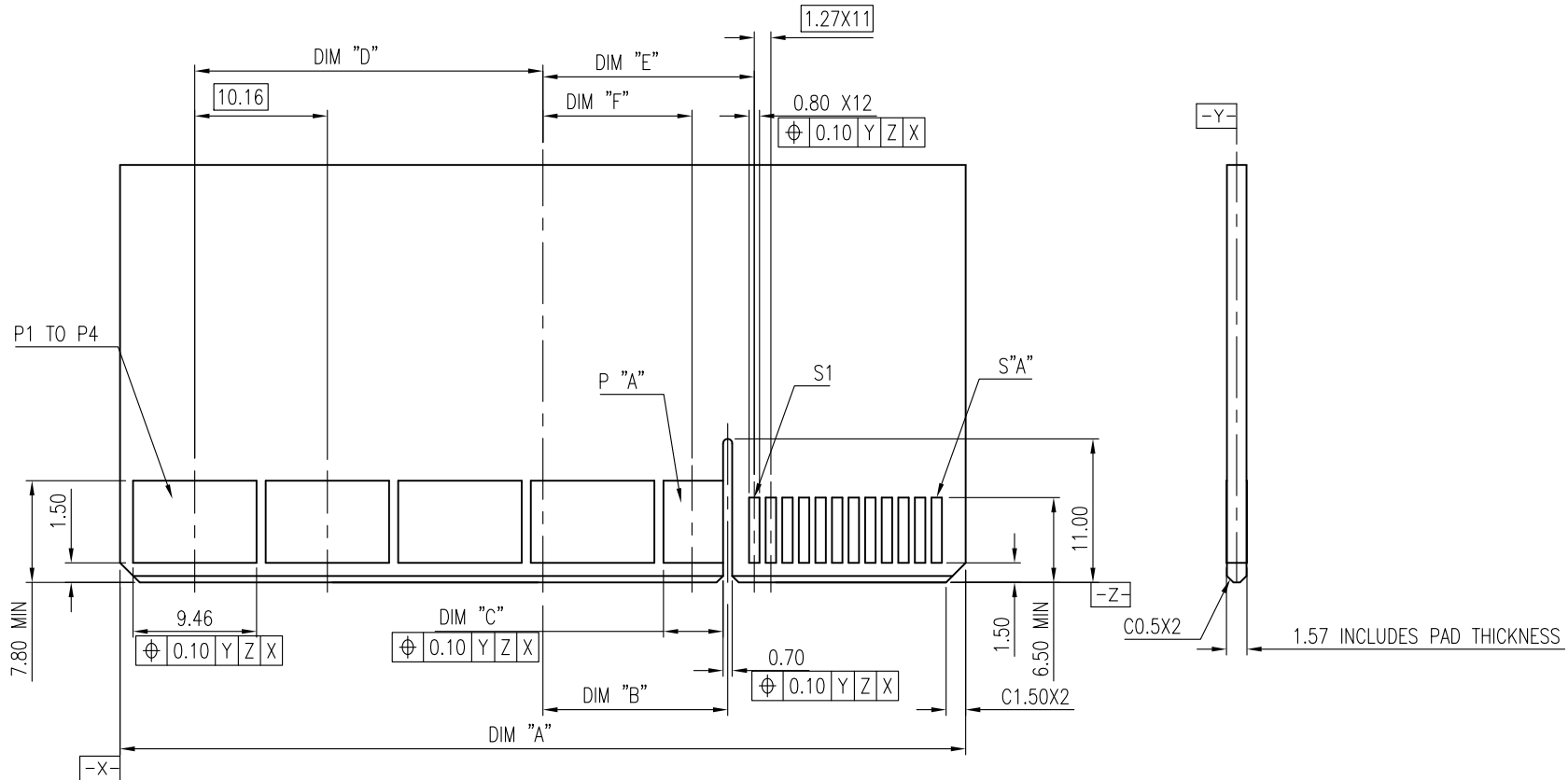

RECOMMENDED MATING BOARD FOOTPRINT

GPCE3X56241HR	90.18	26.86	9.46	39.37	28.90	21.59	P28	S12
GPCE3X48121HR	72.40	25.59	9.46	30.48	27.63	20.42	P24	S6
GPCE3X36241HR	64.78	14.61	4.57	26.67	16.2	11.43	P18	S12
GPCE3X24241HR	49.54	6.54	9.46	19.05	8.58	1.27	P12	S12
GPCE3X16241HR	39.38	1.46	9.46	13.97	3.50	3.81	P8	S12
GPCE3X08201HR	26.68	2.45		7.52	0.40			S10
PART NUMBER	DIM "A"	DIM "B"	DIM "C"	DIM "D"	DIM "E"	DIM "F"	P "A"	S "A"

TOLERANCE	DRAWN	APPROVALS	DATE	TITLE	UNIT	SCALE	SIZE	PART No.
X. ±0.30	DESIGNED	Chenny Yeh	2/8/2012	ENERGY EDGE RECEPTACLE,PRESS-FIT TYPE	mm	NA	A3	GPCE3XXXXX1HR
X.X ±0.20	CHECKED	Sondra Sang	2/8/2012					
X.XXX ±0.10	APPROVED	Hank Hsu	2/8/2012					
ANGULAR ±2°	DWG TYPE	CUST DWG		PROJECT CODE	T521		SHEET	DWG No.
UNLESS OTHERWISE SPECIFIED					3	OF 4	GPCE3X36241HR	REV. A

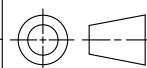

Amphenol[®]
Amphenol Corporation
Amphenol Taiwan Corporation

on the express condition that it is not to be disclosed, reproduced or used, in whole or in part, for manufacture or sale by anyone other than Amphenol Corporation without its prior consent, and that no right is granted to disclose or to use any information in this document.

The marking on this product doesn't contain environmental hazardous material and must follow one or more specifications per Material Specification SS-00259 for Sony GP compliant or per directive 2002/95/EC for RoHS compliant or per IEC 61249-2-21 for Halogen Free compliant.

REVISIONS				
SYM	ECN No.	DESCRIPTION	DATE	BY
A	NE-12016	RELEASE TO PRODUCTION	02/03/2012	Chenny Yeh

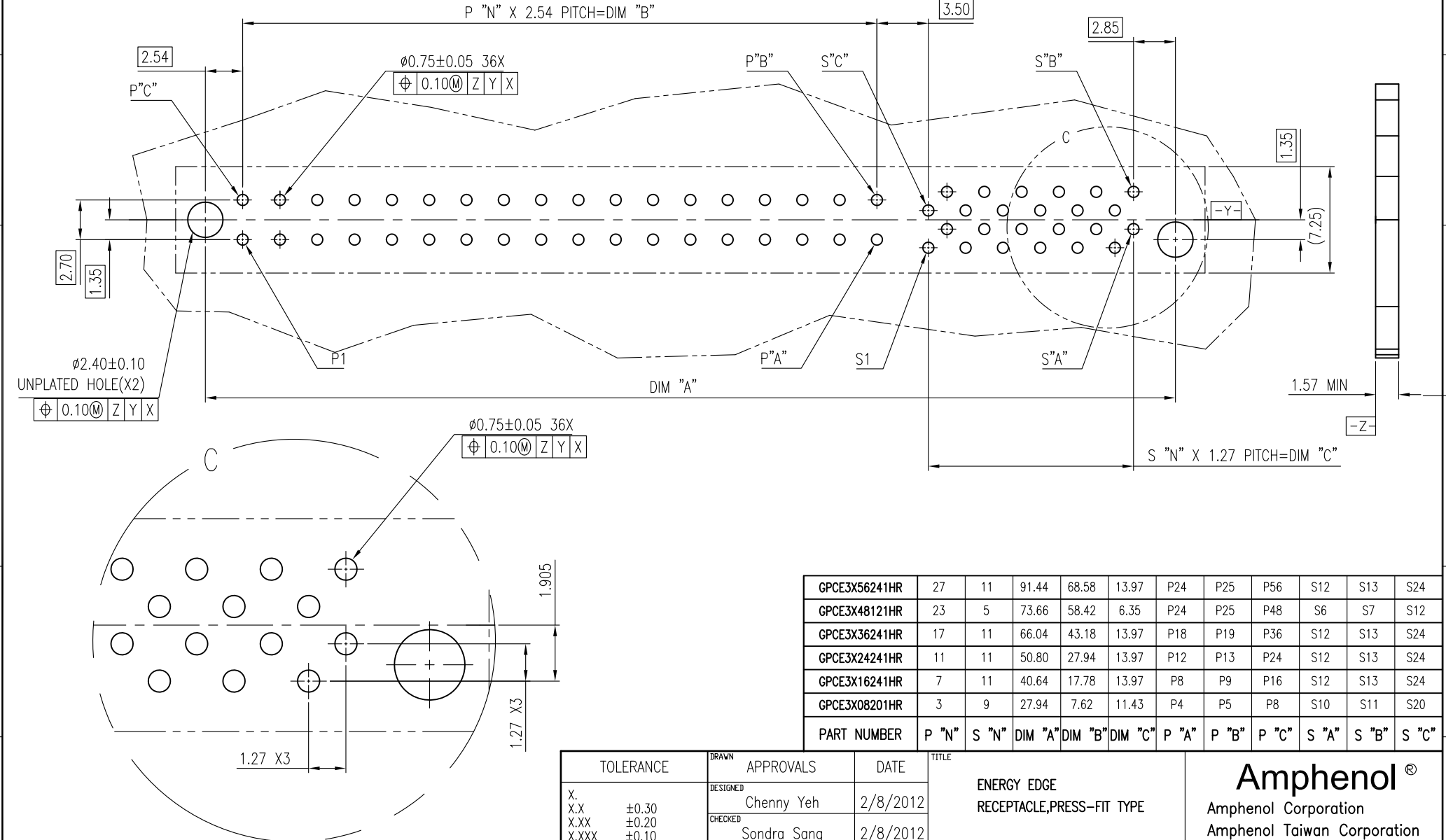

GPCE3X56241HR	27	11	91.44	68.58	13.97	P24	P25	P56	S12	S13	S24
GPCE3X48121HR	23	5	73.66	58.42	6.35	P24	P25	P48	S6	S7	S12
GPCE3X36241HR	17	11	66.04	43.18	13.97	P18	P19	P36	S12	S13	S24
GPCE3X24241HR	11	11	50.80	27.94	13.97	P12	P13	P24	S12	S13	S24
GPCE3X16241HR	7	11	40.64	17.78	13.97	P8	P9	P16	S12	S13	S24
GPCE3X08201HR	3	9	27.94	7.62	11.43	P4	P5	P8	S10	S11	S20
PART NUMBER	P "N"	S "N"	DIM "A"	DIM "B"	DIM "C"	P "A"	P "B"	P "C"	S "A"	S "B"	S "C"

TOLERANCE	DRAWN	APPROVALS	DATE	TITLE	UNIT	SIZE	PART No.
X. ±0.30	DESIGNED	Chenny Yeh	2/8/2012	ENERGY EDGE RECEPTACLE,PRESS-FIT TYPE	mm	A3	GPCE3XXXXX1HR
X.X ±0.20	CHECKED	Sondra Sang	2/8/2012				
X.XXX ±0.10	APPROVED	Hank Hsu	2/8/2012				
ANGULAR ±2°	DWG TYPE	CUST DWG	PROJECT CODE	T521	SCALE	NA	SHEET
UNLESS OTHERWISE SPECIFIED						4 OF 4	DWG No.
							GPCE3X36241HR
							REV. A

SCALE 8:1

X-ON Electronics

Largest Supplier of Electrical and Electronic Components

Click to view similar products for [Power to the Board](#) category:

Click to view products by [Amphenol](#) manufacturer:

Other Similar products are found below :

[6450171-4](#) [6450552-7](#) [6600323-8](#) [6643429-1](#) [6646040-2](#) [6651939-1](#) [6766604-1](#) [120959-1](#) [1393557-2](#) [1393532-2](#) [1393532-3](#) [1393532-4](#)
[1393557-1](#) [1600812-5](#) [1-6450861-2](#) [1744132-7](#) [1761122-1](#) [1766250-1](#) [1892109-1](#) [2-6450860-5](#) [2-6450870-0](#) [1-6450161-4](#) [1-6450850-6](#) [1-](#)
[6450869-6](#) [1645526-2](#) [1-6600130-0](#) [2005243-2](#) [TE34-12-16P-F0](#) [5-6450830-6](#) [5646956-4](#) [4-6450830-9](#) [4-6600333-3](#) [10125416-4050LF](#)
[6600320-3](#) [3-6450860-5](#) [1888123-2](#) [6450166-1](#) [6643978-1](#) [6766605-1](#) [N11444](#) [6651938-1](#) [6450810-7](#) [46437-1112](#) [1-1589677-8](#) [5646956-5](#)
[6450813-2](#) [6450129-4](#) [1645523-1](#) [PSS-06-01-T-S](#) [0465621864](#)