

REVISIONS				
REV	DESCRIPTION	ECN	BY	DATE
A	RELEASED	J05-0270	H.T	5/10/05

CAT. NO. & DIMENSIONS

NO. OF CONTACTS (n)	CAT. NO.		DIMENSIONS (NOTE 1)		
	RIGHT ANGLE TYPE	STRAIGHT TYPE	A ± 0.3	B ± 0.1	C
4	HLW 4R-2C7LF	HLW 4S-2C7LF	6.6	5.12	3.0
5	HLW 5R-2C7LF	HLW 5S-2C7LF	7.6	6.12	4.0
6	HLW 6R-2C7LF	HLW 6S-2C7LF	8.6	7.12	5.0
7	HLW 7R-2C7LF	HLW 7S-2C7LF	9.6	8.12	6.0
8	HLW 8R-2C7LF	HLW 8S-2C7LF	10.6	9.12	7.0
9	HLW 9R-2C7LF	HLW 9S-2C7LF	11.6	10.12	8.0
10	HLW 10R-2C7LF	HLW 10S-2C7LF	12.6	11.12	9.0
11	HLW 11R-2C7LF	HLW 11S-2C7LF	13.6	12.12	10.0
12	HLW 12R-2C7LF	HLW 12S-2C7LF	14.6	13.12	11.0
13	HLW 13R-2C7LF	HLW 13S-2C7LF	15.6	14.12	12.0
14	HLW 14R-2C7LF	HLW 14S-2C7LF	16.6	15.12	13.0
15	HLW 15R-2C7LF	HLW 15S-2C7LF	17.6	16.12	14.0
16	HLW 16R-2C7LF	HLW 16S-2C7LF	18.6	17.12	15.0
17	HLW 17R-2C7LF	HLW 17S-2C7LF	19.6	18.12	16.0
18	HLW 18R-2C7LF	HLW 18S-2C7LF	20.6	19.12	17.0
19	HLW 19R-2C7LF	HLW 19S-2C7LF	21.6	20.12	18.0
20	HLW 20R-2C7LF	HLW 20S-2C7LF	22.6	21.12	19.0
21	HLW 21R-2C7LF	HLW 21S-2C7LF	23.6	22.12	20.0
22	HLW 22R-2C7LF	HLW 22S-2C7LF	24.6	23.12	21.0
23	HLW 23R-2C7LF	HLW 23S-2C7LF	25.6	24.12	22.0
24	HLW 24R-2C7LF	HLW 24S-2C7LF	26.6	25.12	23.0
25	HLW 25R-2C7LF	HLW 25S-2C7LF	27.6	26.12	24.0
26	HLW 26R-2C7LF	HLW 26S-2C7LF	28.6	27.12	25.0
27	HLW 27R-2C7LF	HLW 27S-2C7LF	29.6	28.12	26.0
28	HLW 28R-2C7LF	HLW 28S-2C7LF	30.6	29.12	27.0
29	HLW 29R-2C7LF	HLW 29S-2C7LF	31.6	30.12	28.0
30	HLW 30R-2C7LF	HLW 30S-2C7LF	32.6	31.12	29.0
31	HLW 31R-2C7LF	HLW 31S-2C7LF	33.6	32.12	30.0
32	HLW 32R-2C7LF	HLW 32S-2C7LF	34.6	33.12	31.0

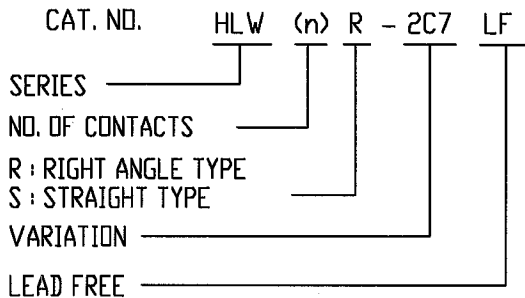

NOTES

1. SEE PART DRAWINGS FOR DIMENSIONS A~C.

SHEET INDEX	ISSUE	A																	
	SH NO.	1																	
TOLERANCES UNLESS OTHERWISE SPECIFIED		DR	<i>T. Sasaki</i>		DATE	5/11/05		CUSTOMER COPY	TITLE CAT NO. TABLE FOR 1mm SPACING CONNECTOR (Cat. No. : HLW__R/S-2C7LF)										
LINEAR		ENGR	<i>H. Takahashi</i>		DATE	5/13/05		 THIRD ANGLE PROJ											
		CHK	<i>H. Takahashi</i>		DATE	5/13/05													
ANGLES		APPD	<i>H. Takahashi</i>		DATE	5/13/05		UNIT	MM	PRODUCT FAMILY	58JF		CODE	JP					
DO NOT SCALE PRINT										THIS INFORMATION IS CONFIDENTIAL AND IS DISCLOSED TO YOU ON CONDITION THAT NO FURTHER DISCLOSURE IS MADE BY YOU TO OTHER THAN FCI PERSONNEL WITHOUT WRITTEN AUTHORIZATION FROM FCI JAPAN K.K.									
DF-140A REV A		JSA96405 96406 93382 93383		SCALE	mm	SIZE	X	DWG. NO.	JSA 96403		REV	A	SHEET	1 OF 1					

REVISIONS				
REV	DESCRIPTION	ECN	BY	DATE
A	RELEASED	J05-0270	H.T	5/10/05
B	Added heat resistance	J05-0735	H.T	10/28/05

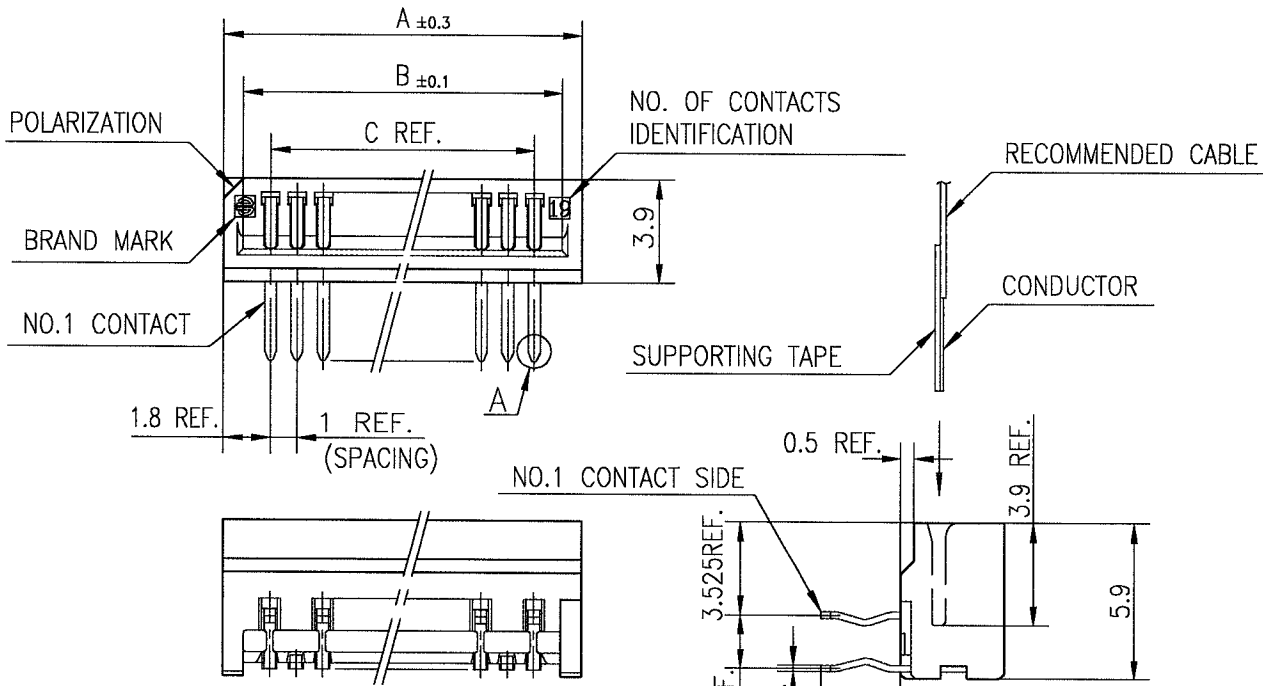

MATERIAL

INSULATOR : PBT RESIN GLASS REINFORCED (UL94V-0)
 COLOR : BLACK
 CONTACT : PHOSPHOR BRONZE
 PLATING : TIN

NOTE

1. THIS PRODUCT IS RIGHT ANGLE TYPE CONNECTOR.
2. THIS PRODUCT MEETS EUROPEAN UNION DIRECTIVES AND OTHER COUNTRY REGULATIONS AS DESCRIBED IN GS-22-008.
3. THE HOUSING WILL WITHSTAND EXPOSURE TO 260°C PEAK TEMPERATURE FOR 10 SECONDS IN A WAVE SOLDER APPLICATION WITH A 1.6mm THICK CIRCUIT BOARD.

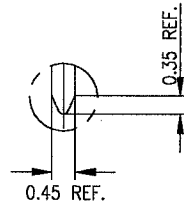

DETAIL A

RECOMMENDED PC BOARD

THICKNESS : 1.2~1.6
 HOLE PATTERN (COMPONENT SIDE)

n : NO. OF CONTACTS

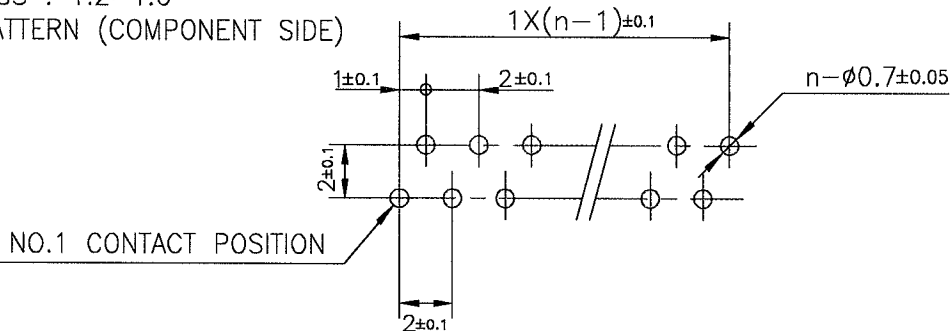

SHEET INDEX	ISSUE	B									
	SH NO.	1									
TOLERANCES UNLESS OTHERWISE SPECIFIED		DR	<i>M. Murayama</i>	DATE	10/28/05	CUSTOMER COPY	TITLE				
LINEAR	±0.2	ENGR	<i>H. Takahashi</i>		5/11/01		1mm SPACING CONNECTOR FOR FPC/FFC (Cat. No. :HLW__R-2C7LF)				
		CHK	<i>H. Takahashi</i>		10/31/05		THIRD ANGLE PROJ	PRODUCT FAMILY		58JF	CODE JP
ANGLES		APPD	<i>S. Oda</i>		11/1/08	UNIT	MM				
DO NOT SCALE PRINT		THIS INFORMATION IS CONFIDENTIAL AND IS DISCLOSED TO YOU ON CONDITION THAT NO FURTHER DISCLOSURE IS MADE BY YOU TO OTHER THAN FCI PERSONNEL WITHOUT WRITTEN AUTHORIZATION FROM FCI JAPAN K.K.					SCALE	SIZE	DWG. NO.	REV	SHEET
DF-140A REV A							∕	A	JSA 96405	B	1 of 1

SC-HLW05 JSA96403

REVISIONS				
REV	DESCRIPTION	ECN	BY	DATE
A	RELEASED	J05-0270	H.T	5/10/05
B	Added heat resistance	J05-0735	H.T	10/28/05

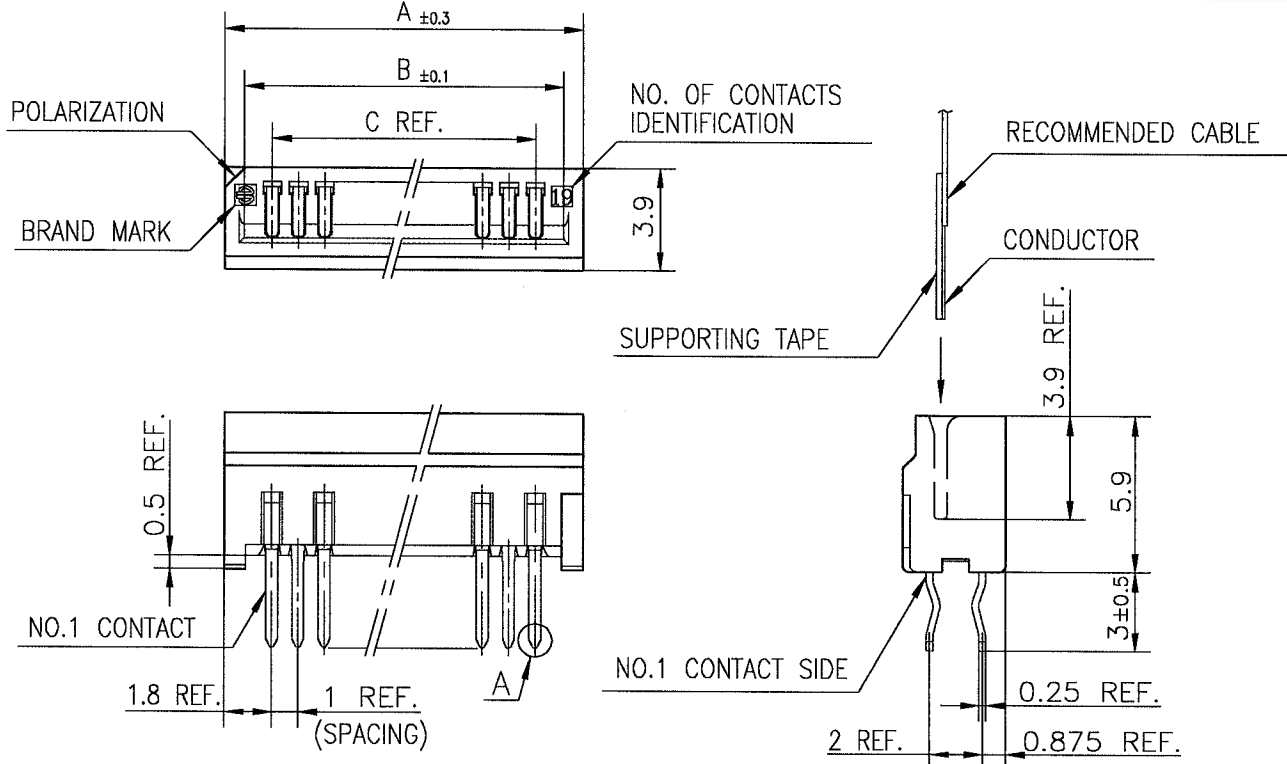

MATERIAL

INSULATOR : PBT RESIN GLASS REINFORCED (UL94V-0)
 COLOR : BLACK
 CONTACT : PHOSPHOR BRONZE
 PLATING : TIN

- NOTE 1. THIS PRODUCT IS STRAIGHT TYPE CONNECTOR.
 2. THIS PRODUCT MEETS EUROPEAN UNION DIRECTIVES AND OTHER COUNTRY REGULATIONS AS DESCRIBED IN GS-22-008.
 3. THE HOUSING WILL WITHSTAND EXPOSURE TO 260°C PEAK TEMPERATURE FOR 10 SECONDS IN A WAVE SOLDER APPLICATION WITH A 1.6mm THICK CIRCUIT BOARD.

RECOMMENDED PC BOARD

THICKNESS : 1.2~1.6
 HOLE PATTERN (COMPONENT SIDE)

n : NO. OF CONTACTS

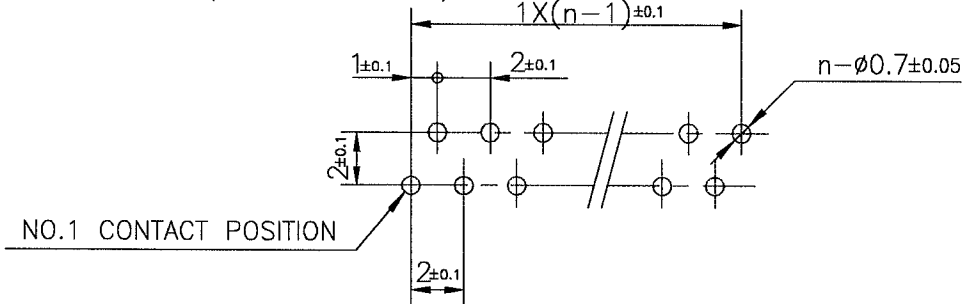

SHEET INDEX	ISSUE	B											TITLE 1mm SPACING CONNECTOR FOR FPC/FFC (Cat. No. :HLW__S-2C7LF)
	SH NO.	1											
TOLERANCES UNLESS OTHERWISE SPECIFIED	DR	<i>M. Motomura</i>		DATE	10/28/05		CUSTOMER COPY	THIRD ANGLE PROJ UNIT $\frac{MM}{INCH}$					
	ENGR	<i>H. Kobayashi</i>		DATE	10/31/05								
	CHK	<i>H. Kobayashi</i>		DATE	11/1/05								
LINEAR	± 0.2	APPD	<i>S. Sudo</i>		DATE	11/1/05		PRODUCT FAMILY	58JF		CODE JP		
ANGLES								SCALE	SIZE	DWG. NO.	REV	SHEET	
DO NOT SCALE PRINT		THIS INFORMATION IS CONFIDENTIAL AND IS DISCLOSED TO YOU ON CONDITION THAT NO FURTHER DISCLOSURE IS MADE BY YOU TO OTHER THAN FCI PERSONNEL WITHOUT WRITTEN AUTHORIZATION FROM FCI JAPAN K.K.							\times	A	JSA 96406	B	1 OF 1

REVISIONS				
REV	DESCRIPTION	ECN	BY	DATE
AA	Changed form	J05-0270	H.T	5/11/05

RECOMMENDED CABLE (FPC)

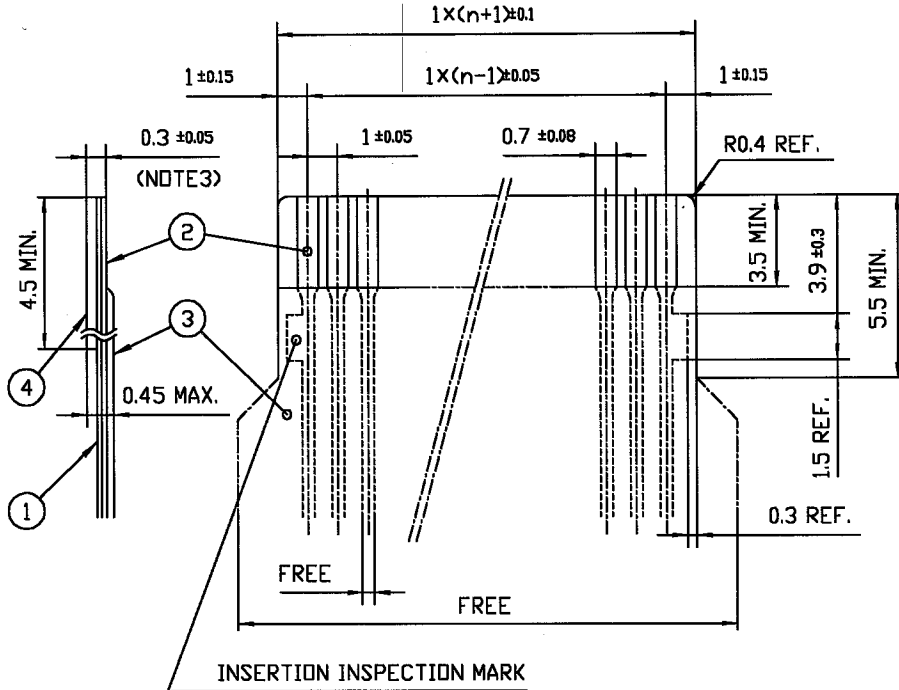

n : NO. OF CONDUCTORS



PT. NO.	DESCRIPTION	MATERIAL	THICKNESS (μm)
1	BASE FILM	POLYIMIDE OR POLYESTER OR EQUIVALENT	25
2	CONDUCTOR	COPPER FOIL (PLATING : SOLDER 1μm MIN.)	35
3	OVERLAY	POLYIMIDE OR POLYESTER OR EQUIVALENT	—
4	SUPPORTING TAPE	POLYESTER OR POLYIMIDE OR EQUIVALENT	188

NOTES

1. NO BURR AT EACH PORTION.
2. NO PEELING IN COMMON USE.
3. TOTAL THICKNESS LIMIT OF EACH MATERIAL (INCLUDING ADHESIVE AGENT) IS SPECIFIED.

SHEET INDEX	ISSUE	AA													
	SH NO.	1													
TOLERANCES UNLESS OTHERWISE SPECIFIED		DR	<i>T. Sasaki</i>	DATE	5/11/05	CUSTOMER COPY	TITLE								
LINEAR		ENGR	<i>H. Takahara</i>	5/13/05		RECOMMENDED CABLE (FPC) (Cat. No. HLW__R/S-__)									
		CHK	<i>H. Takahara</i>	5/13/05		THIRD ANGLE PROJ	PRODUCT FAMILY								
ANGLES		APPD	<i>M. Masuoka</i>	5/17/05	UNIT	MM	58JF	CODE		JP					
DO NOT SCALE PRINT	THIS INFORMATION IS CONFIDENTIAL AND IS DISCLOSED TO YOU ON CONDITION THAT NO FURTHER DISCLOSURE IS MADE BY YOU TO OTHER THAN FCI PERSONNEL WITHOUT WRITTEN AUTHORIZATION FROM FCI JAPAN K.K.					SCALE	4/1	SIZE	A	DWG. NO.	JSA93382	REV	AA	SHEET	OF

REVISIONS				
REV	DESCRIPTION	ECN	BY	DATE
AA	Changed form	J05-0274	H.T	5/11/05

RECOMMENDED CABLE (FFC)

n : NO. OF CONDUCTORS

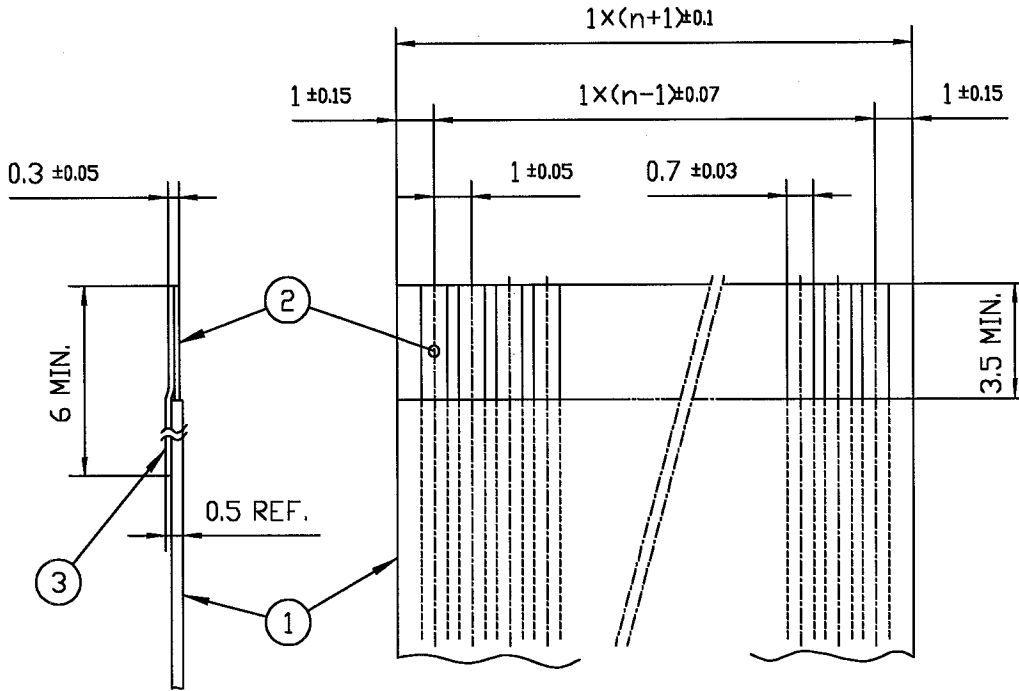

PT. NO.	DESCRIPTION	MATERIAL	NOTE
1	INSULATOR	FLAME RESISTING POLYESTER OR EQUIVALENT	_____
2	CONDUCTOR	COPPER FOIL	PLATING : TIN OR SOLDER 1μm MIN.
3	SUPPORTING TAPE	FLAME RESISTING POLYESTER OR EQUIVALENT	_____

NOTES

1. NO BURR AT EACH PORTION.
2. NO PEELING IN COMMON USE.

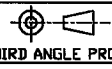
SHEET INDEX	ISSUE	AA																		
	SH NO.	1																		
TOLERANCES UNLESS OTHERWISE SPECIFIED		DR	<i>T. Sasaki</i>		DATE	5/11/05		CUSTOMER COPY	TITLE											
LINEAR		ENGR	<i>H. Takahara</i>		DATE	5/13/05		 THIRD ANGLE PROJ	RECOMMENDED CABLE(FFC)											
		CHK	<i>H. Takahara</i>		DATE	5/13/05			(Cat. No. HLW__R/S-__)											
		APPD	<i>M. Hasegawa</i>		DATE	5/17/05			PRODUCT FAMILY											
ANGLES		UNIT	MM		CODE JP															
DO NOT SCALE PRINT		THIS INFORMATION IS CONFIDENTIAL AND IS DISCLOSED TO YOU ON CONDITION THAT NO FURTHER DISCLOSURE IS MADE BY YOU TO OTHER THAN FCI PERSONNEL WITHOUT WRITTEN AUTHORIZATION FROM FCI JAPAN K.K.										SCALE	SIZE	DWG. NO.	REV	SHEET				
DF-140A REV A												-	A	JSA 93383	AA	DF				

REVISIONS				
REV	DESCRIPTION	ECN	BY	DATE
A	RELEASED	J05-0270	H.T	5/10/05
B	Added heat resistance	J05-0735	H.T	10/28/05

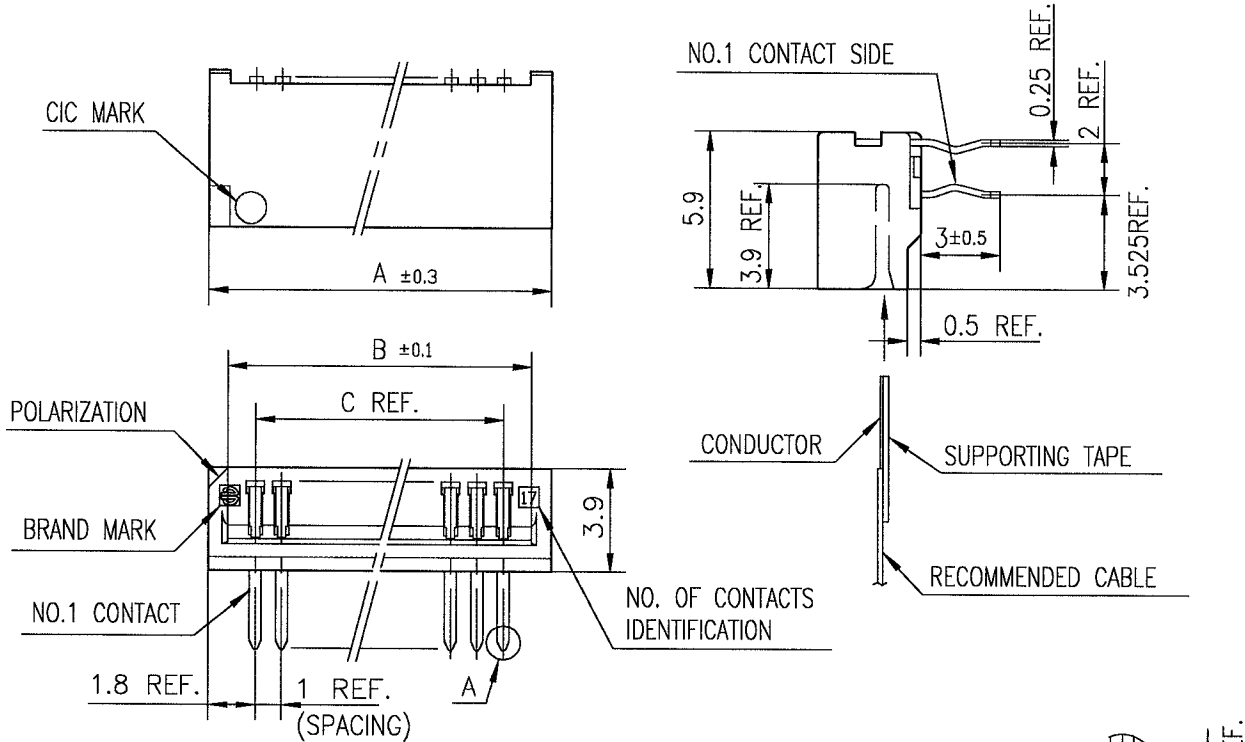

MATERIAL

INSULATOR : PBT RESIN GLASS REINFORCED (UL94V-0)
 COLOR : BLACK
 CONTACT : PHOSPHOR BRONZE
 PLATING : TIN

NOTE

1. THIS PRODUCT IS RIGHT ANGLE TYPE CONNECTOR.
2. THIS PRODUCT MEETS EUROPEAN UNION DIRECTIVES AND OTHER COUNTRY REGULATIONS AS DESCRIBED IN GS-22-008.
3. THE HOUSING WILL WITHSTAND EXPOSURE TO 260°C PEAK TEMPERATURE FOR 10 SECONDS IN A WAVE SOLDER APPLICATION WITH A 1.6mm THICK CIRCUIT BOARD.

RECOMMENDED PC BOARD

THICKNESS : 1.2~1.6
 HOLE PATTERN (COMPONENT SIDE)

n : NO. OF CONTACTS

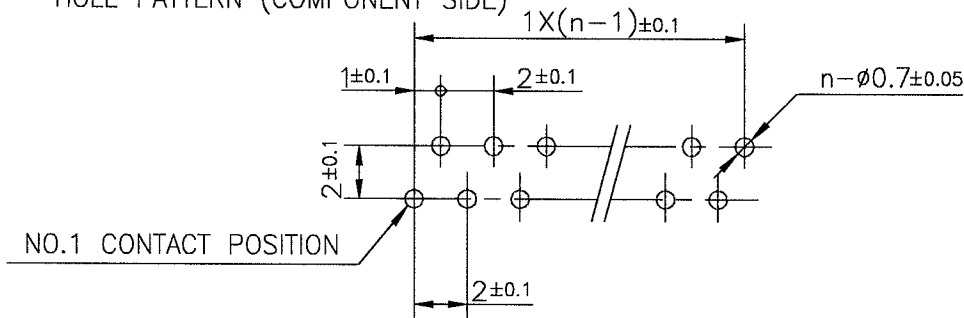

SHEET INDEX	ISSUE	B									
	SH NO.	1									
TOLERANCES UNLESS OTHERWISE SPECIFIED		DR	<i>M. Matsuyama</i>	DATE	10/28/05	CUSTOMER COPY	TITLE				
LINEAR	±0.2	ENGR	<i>H. Hatakeyama</i>		10/21/05		1mm SPACING CONNECTOR FOR CIC (Cat. No. :HLW__R-6C7LF)				
		CHK	<i>H. Hatakeyama</i>		10/31/05		THIRD ANGLE PROJ	PRODUCT FAMILY		58JF	CODE JP
ANGLES		APPD	<i>S. Ochiai</i>		11/11/05	UNIT	MM				
DO NOT SCALE PRINT		THIS INFORMATION IS CONFIDENTIAL AND IS DISCLOSED TO YOU ON CONDITION THAT NO FURTHER DISCLOSURE IS MADE BY YOU TO OTHER THAN FCI PERSONNEL WITHOUT WRITTEN AUTHORIZATION FROM FCI JAPAN K.K.					SCALE	SIZE	DWG. NO.	REV	SHEET
DF-140A REV A							X	A	JSA 96407	B	1 of 1

SC-HLW06 JSA96404

REVISIONS				
REV	DESCRIPTION	ECN	BY	DATE
A	RELEASED	J05-0270	H.T	5/10/05
B	Added heat resistance	J05-0735	H.T	10/28/05

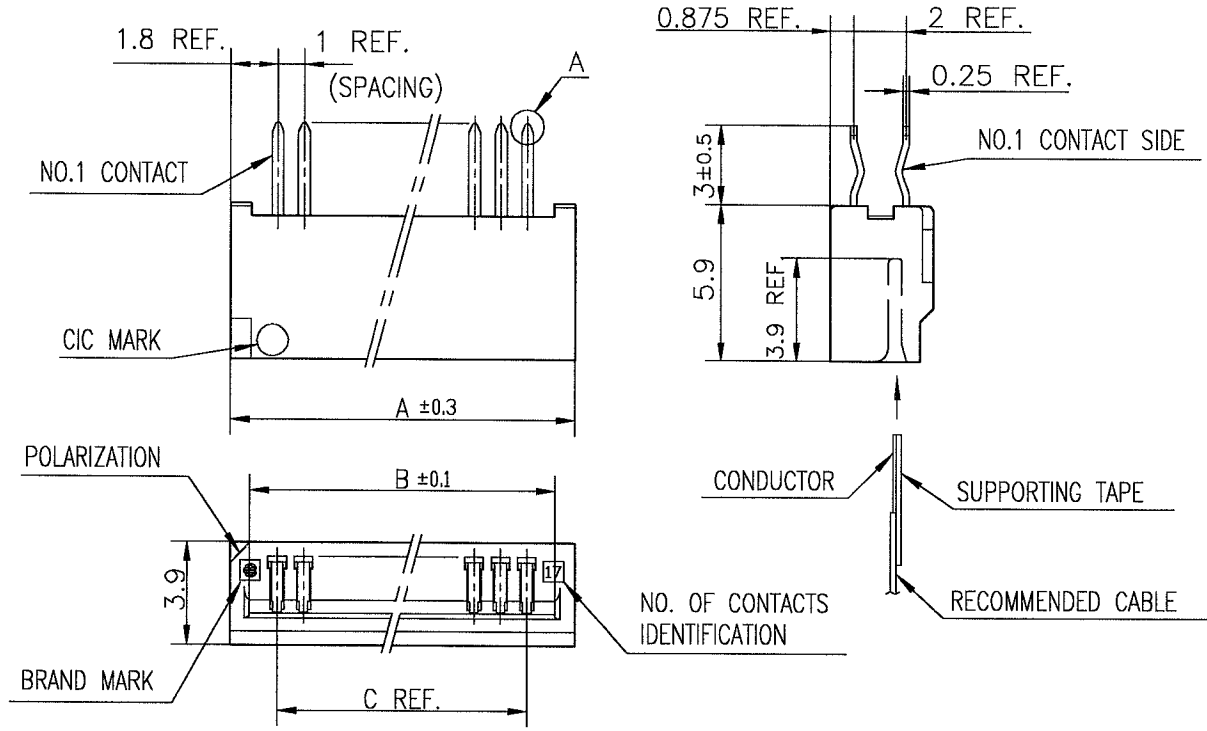

MATERIAL
 INSULATOR : PBT RESIN GLASS REINFORCED (UL94V-0)
 COLOR : BLACK
 CONTACT : PHOSPHOR BRONZE
 PLATING : TIN

NOTE
 1. THIS PRODUCT IS STRAIGHT TYPE CONNECTOR.
 2. THIS PRODUCT MEETS EUROPEAN UNION DIRECTIVES AND OTHER COUNTRY REGULATIONS AS DESCRIBED IN GS-22-008.
 3. THE HOUSING WILL WITHSTAND EXPOSURE TO 260°C PEAK TEMPERATURE FOR 10 SECONDS IN A WAVE SOLDER APPLICATION WITH A 1.6mm THICK CIRCUIT BOARD.
 RECOMMENDED PC BOARD THICKNESS : 1.2~1.6
 HOLE PATTERN (COMPONENT SIDE)
 n : NO. OF CONTACTS

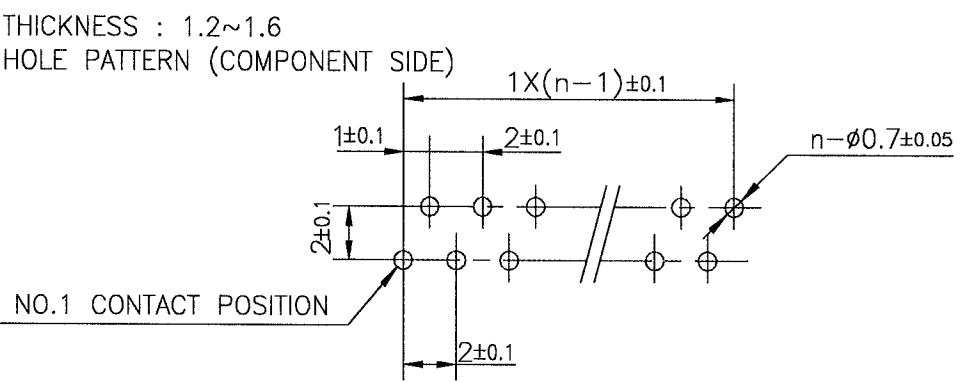

SHEET INDEX	ISSUE	B									
	SH NO.	1									
TOLERANCES UNLESS OTHERWISE SPECIFIED		DR	<i>[Signature]</i>	DATE	10/28/05	CUSTOMER COPY	TITLE				
LINEAR	±0.2	ENGR	<i>[Signature]</i>		10/21/05		1mm SPACING CONNECTOR FOR CIC (Cat. No. :HLW__S-6C7LF)				
		CHK	<i>[Signature]</i>		10/21/05		THIRD ANGLE PROJ				
ANGLES		APPD	<i>[Signature]</i>		11/11/05	UNIT	MM	PRODUCT FAMILY	58JF	CODE JP	
DO NOT SCALE PRINT		THIS INFORMATION IS CONFIDENTIAL AND IS DISCLOSED TO YOU ON CONDITION THAT NO FURTHER DISCLOSURE IS MADE BY YOU TO OTHER THAN FCI PERSONNEL WITHOUT WRITTEN AUTHORIZATION FROM FCI JAPAN K.K.					SCALE	SIZE	DWG. NO.	REV	SHEET
DF-140A REV A							X	A	JSA 96408	B	1 of 1

SC-HLW 06 JSA96404

REVISIONS				
REV	DESCRIPTION	ECN	BY	DATE
AA	Changed form	J05-0270	H.T	5/11/05

RECOMMENDED CABLE (CIC)

n : NO. OF CONDUCTORS

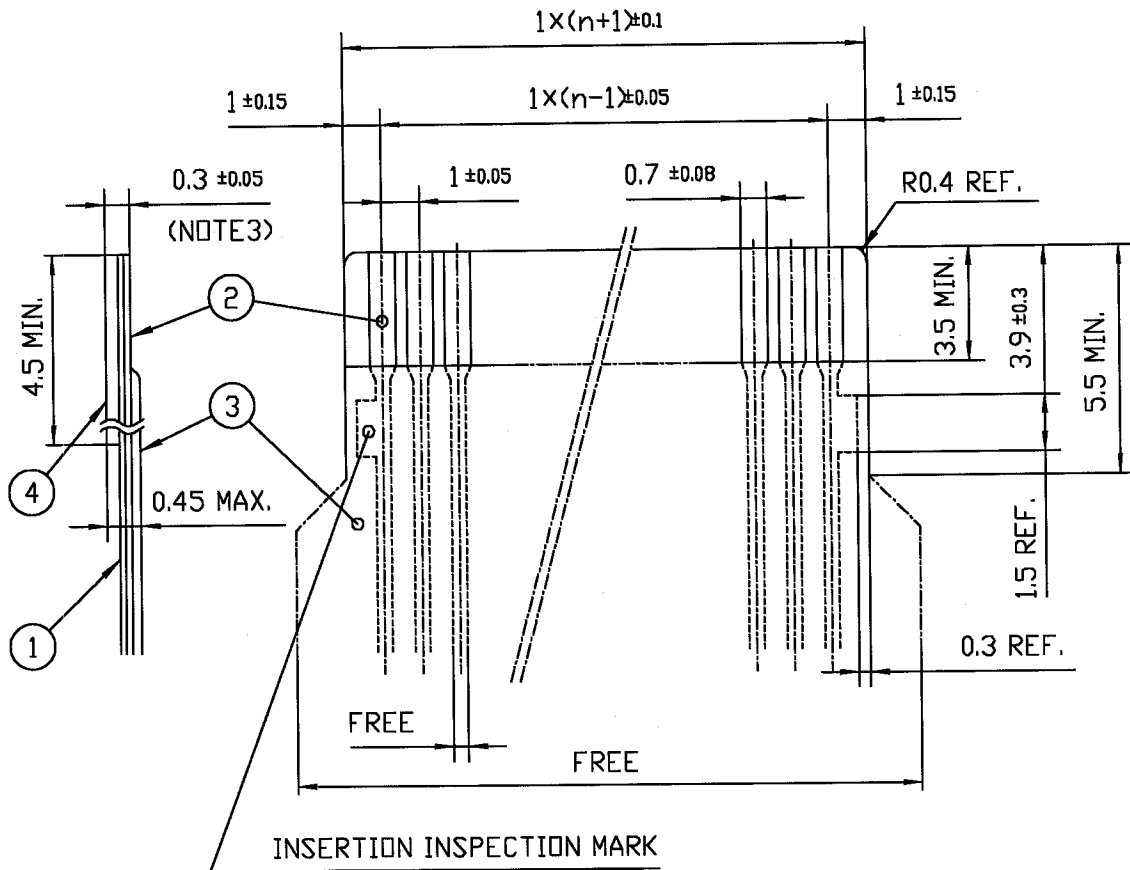

PT. NO.	DESCRIPTION	MATERIAL	THICKNESS (μm)	
1	BASE FILM	POLYESTER OR EQUIVALENT	75	25
2	CONDUCTOR	CARBON PASTE OVER SILVER PASTE	10 MIN.	
3	OVERLAY	POLYIMIDE OR POLYESTER OR EQUIVALENT	—	
4	SUPPORTING TAPE	POLYESTER OR POLYIMIDE OR EQUIVALENT	188	250

NOTES

1. NO BURR AT EACH PORTION.
2. NO PEELING IN COMMON USE.
3. TOTAL THICKNESS LIMIT OF EACH MATERIAL (INCLUDING ADHESIVE AGENT) IS SPECIFIED.

SHEET INDEX	ISSUE	AA														
	SH NO.	1														
LINEAR	TOLERANCES UNLESS OTHERWISE SPECIFIED		DR	<i>J. Sasaki</i>	DATE	5/11/05	CUSTOMER COPY	TITLE RECOMMENDED CABLE (CIC) (Cat. No. HLW__R/S-___)								
			ENGR	<i>H. Takahashi</i>		5/12/05	THIRD ANGLE PROJ									
				CHK	<i>H. Takahashi</i>		5/12/05	UNIT	MM	INCH						
ANGLES			APPD	<i>M. Hasegawa</i>		5/12/05		PRODUCT FAMILY	58JF	CODE JP						
DO NOT SCALE PRINT		THIS INFORMATION IS CONFIDENTIAL AND IS DISCLOSED TO YOU ON CONDITION THAT NO FURTHER DISCLOSURE IS MADE BY YOU TO OTHER THAN FCI PERSONNEL WITHOUT WRITTEN AUTHORIZATION FROM FCI JAPAN K.K.					SCALE	5/1	SIZE	A	DWG. NO.	JSA93626	REV	AA	SHEET	OF

X-ON Electronics

Largest Supplier of Electrical and Electronic Components

Click to view similar products for [FFC & FPC Connectors](#) category:

Click to view products by [Amphenol](#) manufacturer:

Other Similar products are found below :

[K-FC20](#) [FH29B-80S-0.2SHW\(99\)](#) [FPH-2022G](#) [AYF332735](#) [52610-1075](#) [52610-1275](#) [52610-1934](#) [501864-3091-TR225](#) [086222026001800](#)
[52610-0675](#) [62684-36210E9ALF](#) [52746-1671-TR250](#) [10051922-2810EHLF](#) [6-520415-9](#) [SFV6R-1STE9HLF](#) [XF3M-2915-1B-R100](#)
[1658549-1](#) [46214008010800](#) [AYF534065TA](#) [AYF351525](#) [086212040340800+](#) [AYF530365TA](#) [67000-014LF](#) [67000-004LF](#)
[006207341915000+](#) [DS1020-19RT1D](#) [67000-003LF](#) [67000-011LF](#) [67000-016LF](#) [HFW14R-2STE9LF](#) [SFV32R-2STBE9HLF](#) [SFW12R-](#)
[5STE9LF](#) [SFW18R-1STAE9LF](#) [SFW4R-5STE9LF](#) [52807-0430](#) [046283021002868+](#) [THD1015-8CL-SN](#) [67000-006LF](#) [502250-8027](#)
[104267-9617](#) [66987-011LF](#) [AYF362535](#) [F0501-T-50-20T-R](#) [HFW8S-2STAE1HLF](#) [67000-008LF](#) [67000-012LF](#) [ECC576069EU](#) [F1002-B-](#)
[20-20T-R](#) [HFW15S-2STAE1HLF](#) [5019511030](#)