

Amphenol High Density HDB³/HSB³ Connectors



TABLE OF CONTENTS

Amphenol High Density HDB³ and HSB³ Connectors

- Table of Contents47
- Introduction - Features, Options, Performance 48, 49

HDB³

- HDB³ Mother Board Connector50
- HDB³ Daughter Board Connector51
- HDB³ I/O Connector52
- HDB³ Stacker Connector.....53

HSB³

- HSB³ Mother Board Connector54
- HSB³ Daughter Board Connector.....55
- HSB³ Arrangements56
- Recommended Board Layout - HSB³ Daughter Board.....57
- Recommended Board Layout - HSB³ Mother Board58
- Hardware for both HDB³ and HSB³ Connectors59



HDB³ and HSB³ Typical Markets:

- Transportation
- Medical Equipment
- Military & Commercial Avionics
- C4ISR
- UAVs
- Naval
- High Definition Cameras



New/Featured Product

Amphenol's HDB³ High Density Brush Series with Tighter (.070 inch X .060 inch) Staggered Grid Spacing

This new connector series of brush connectors incorporates a higher density contact pattern and lower mated height than Amphenol's standard low mating force rectangular connectors. HDB³ connectors utilize the same durable and reliable B³ brush contact in a tighter .070" X .060" staggered grid pattern.

HDB³ Advantages over Competitive Connectors:

- Higher density contact pattern
- Uses less board space
- Allows for shorter mated height
- Provides the durability and performance of the Brush contact
- Low cost

AMPHENOL'S BRUSH CONTACT - THE SUPERIOR CHOICE FOR BOARD LEVEL INTERCONNECTS

BRUSH CONTACT

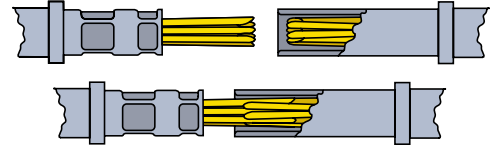

Multiple strands of high tensile strength wire bundled together to form brush-like contacts. See Brush Contact Technology section of this catalog for further description.

CONVENTIONAL PIN AND SOCKET CRIMP CONTACT



AMPHENOL HDB ³ COMPARED TO COMPETITION			
Connector Features	Amphenol HDB3	Hypertronics HPH	Airborn RM4
Contact System	Brush	Hyperloid	Pin & Socket
Durability, Mating Cycles	100,0000	2,000	500
Contact Mating Forces (ounces)	1.5	1.5	2.5
Mother Board	.070 X .060	.075 X .075	.075 X .070
Daughter Board	.070 X .060	.075 X .100	.075 X .100
Connector Width	.350	.443	.400
Mated Height, MB to 4th row of DB	.680	.986	.915



HIGH DENSITY STYLES

HDB³ Daughter Board/Mother Board

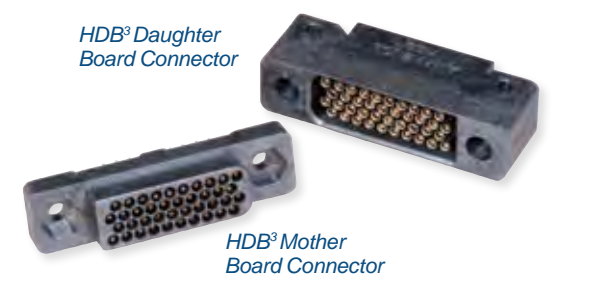

HDB³ I/O Connector

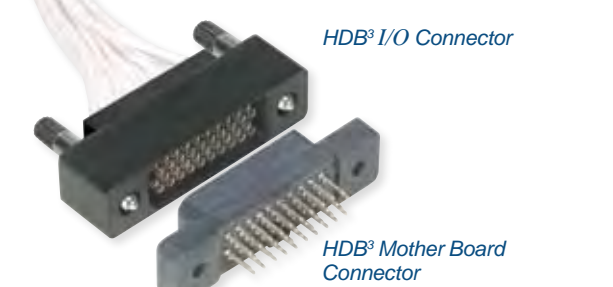

HDB³ Stacker

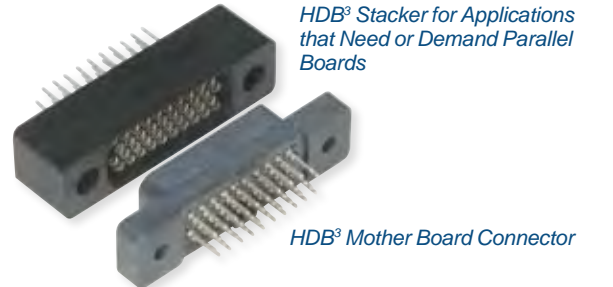

HSB³ High Speed



Introduction/ Pkg. Solutions/ Brush Contact
LRM (Line Replaceable Modules) Options/ Hybrids - Fiber Optics/ Staggered/ GEN-X
Ruggedized VME64x/ VITA 60, 66
High Density HDB³ HSB³ Hi Speed
Low Mating Force MIL-DTL-55302 Hybrids - Signal/Power/ Standard Brush
Docking Conn./ Accessories/Install.
Rack & Panel Brush Ruggedized
LMD/LMS Rectangular Interconnects
Other Rectangular Interconnects

INTRODUCTION: FEATURES & PERFORMANCE



HDB³ 120 pin Mother Board and Daughter Board

HDB³ & HSB³ HIGH DENSITY CONNECTOR PERFORMANCE:

Durability	100,000 mating cycles
Insertion/Extraction Force:	1.5 ounce typical per contact
Operating Temperature:	-65° to 125°C
Current Rating:	2 amperes Hot swap 1 ampere maximum (load dependent)
Insulation Resistance:	5 gigaohms minimum
Dielectric Withstanding Voltage:	750 volts, 60 hertz, rms @ Sea Level, 250 volts, 60 hertz, rms @ 70,000 feet elevation
Solderability:	MIL-STD-202, Method 208
Salt Fog:	48 Hours IAW MIL-STD-1344, method 1001, test condition B
Humidity:	IAW MIL-STD-1344, method 1002, type II
Vibration:	4 hours in each of 3 mutually perpendicular axes IAW MIL STD-1344, method 2005, test condition V, letter H
Shock:	1 shock along each of three mutually perpendicular axes IAW MIL-STD-1344, method 2004, test condition G
Data Rate (HSB ³):	Capable of up to 6.250 Gbps (consult Amphenol for arrangement)

CUSTOM DESIGN AVAILABILITY:

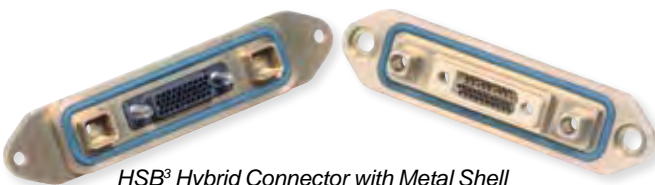

HSB³ Hybrid Connector with Metal Shell and RF Contacts supplied by SV Microwave*

* See more information on SMPM RF contacts in Other Rectangular Interconnects Section, page 126. SMPM RF contacts can be supplied by Amphenol SV Microwave. Phone: 561-840-1800 Website: www.svmicrowave.com

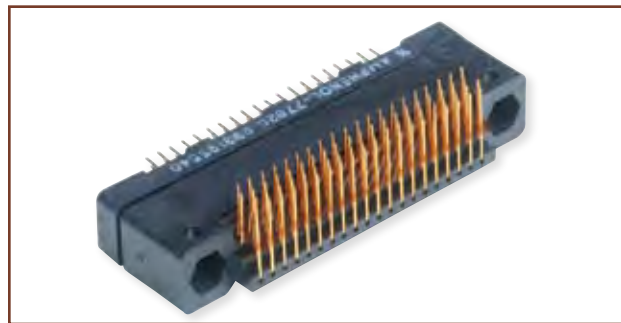

HDB³ Mother Board and Daughter Board Mated

HDB³ & HSB³ HIGH DENSITY CONNECTOR FEATURES:

Polarization:	“D” shaped design
Keying:	Optional keys offer 36 unique keying combinations
Guide Pins	Optional guide pins provide additional alignment
Radial Misalignment:	Capable of correcting up to a 020” initial radial misalignment
Angular Misalignment:	Capable of mating with up to a 2° initial angular misalignment

MATERIALS:

Insulator:	Liquid crystal polymer, 30% glass filled
Contact: Wire:	Beryllium copper per ASTM B197; finish is gold per ASTM B488 over nickel per AMS-QQ-N-290
Holder:	Brass similar to UNS C33500; available finishes include gold per MIL-G-45204, tin-lead per MIL-P-81728 or tin per MIL-T-10727 (RoHS Compliant)
Sleeve:	Stainless steel per AMS-5514, passivated IAW QQ-P-35 (Daughter-board, I/O and Stacker connector)

Introduction/ Pkg. Solutions/ Brush Contact	LRM (Line Replaceable Modules)	Ruggedized VME 64x/ VITA 60, 66	High Density HDB ³ HSB ³ Hi Speed	Low Mating Force MIL-DTL-55302	Rock & Panel Brush Ruggedized	UMD/LMS Rectangular Interconnects	Other Rectangular Interconnects
Staggered/ GEN-X	Hybrids - Fiber Optics/ Hi Speed/RF/Power	Options/ Accessories	Standard Brush	Hybrids - Signal/Power/ Cook/Fiber Optics	Rectangular Interconnects		

Mother Board

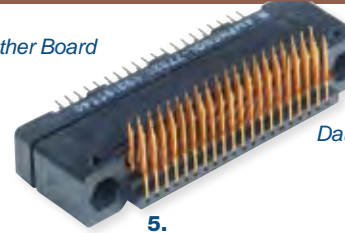

Daughter Board

HDB³ MOTHER BOARD - HOW TO ORDER

Mates with:

- Daughter Board
- I/O
- Stacker

1. Connector Type

HDB-M4

Designates HDB³ Mother Board

	1.	2.	3.	4.	5.	6.
	Number of Contacts	Brush Wire Plating	Termination	Contact Termination Finish	Less Hardware	(Purchased separately see pg XX for hardware options)
HDB-M4	-040	M	24	2	X	

2. Number of Contacts

	Number of Contacts	Dimension A	Dimension C
040	40	1.375	1.075
060	60	1.725	1.425
080	80	2.075	1.775
120	120	2.775	2.475
160	160	3.475	3.175

3. Brush Wire Plating

M	0.000050 Au Min. thick over Nickel
C	0.000020 Au Min. thick over Nickel

4. Termination

	Type	Stickout (Dim. E)
22	PCB, Straight, .016 Dia	0.120
23	PCB, Straight, .016 Dia	0.150
24	PCB, Straight, .016 Dia	0.180
26	PCB, Straight, .016 Dia	0.240
28	PCB, Straight, .016 Dia	0.300

5. Contact Termination Finish

2	Gold plated in accordance with MIL-G-45204, Type II, .000030 Min. thick Gold over .000050 Min. thick Nickel
5	Tin plated in accordance with ASTM B545, .00010 Min. thick Matte Tin over .00010 Min. thick Nickel
6	Tin-Lead plated in accordance with SAE-AMS-P-81728, .00010 Min. thick Tin-Lead over .00010 Min. thick Copper

6. Hardware

X	Less Hardware
----------	---------------

Hardware is purchased separately (see page 59 for hardware options).

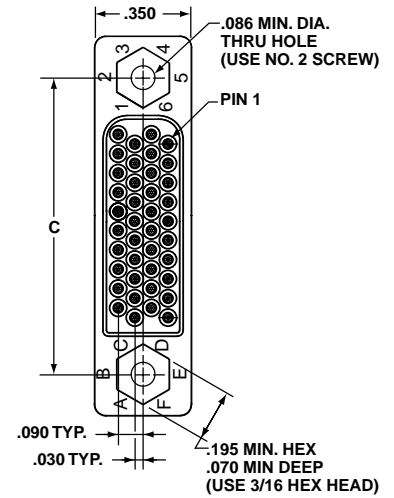
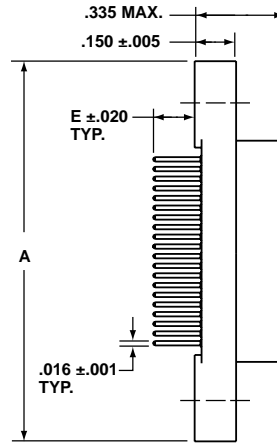

Mother Board Layout

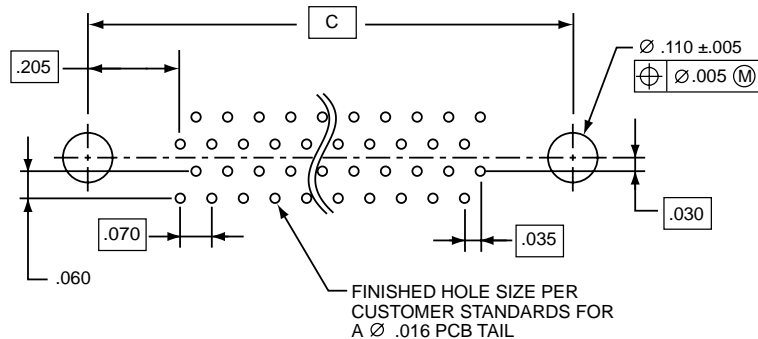

Introduction/
Pkg. Solutions/
Brush Contact

LRM (Line Replaceable Modules)
Options/
Accessories

Ruggedized
VME64x/
VITA 60, 66

High Density
HDB³
HSB
Hi Speed

Low Mating Force MIL-DTL-55302
Docking Conn./
Accessories/Install.

Rack & Panel
Brush
Ruggedized

LMD/LMS
Rectangular
Interconnects

Other
Rectangular
Interconnects

DIMENSIONAL DRAWING & HOW TO ORDER

HDB³ DAUGHTER BOARD - HOW TO ORDER

Mates with:

- Mother Board

1. Connector Type

HDB-D4

Designates HDB³ Daughter Board

	1.	2.	3.	4.	5.	
	HDB-D4	Number of Contacts	Brush Wire Plating	Termination	Contact Termination Finish	Less Hardware (Purchased separately see pg X for hardware options)
		-040	M	01	2	X

2. Number of Contacts

	Number of Contacts	Dimension A	Dimension C
040	40	1.375	1.075
060	60	1.725	1.425
080	80	2.075	1.775
120	120	2.775	2.475
160	160	3.475	3.175

3. Brush Wire Plating

M	0.000050 Au Min. thick over Nickel
C	0.000020 Au Min. thick over Nickel

4. Termination

	Type	Stickout (Dim. E)
01	PCB, Right Angle, .016 Dia.	0.090
02	PCB, Right Angle, .016 Dia.	0.120
03	PCB, Right Angle, .016 Dia.	0.150
04	PCB, Right Angle, .016 Dia.	0.180
06	PCB, Right Angle, .016 Dia.	0.300

5. Contact Termination Finish

2	Gold plated in accordance with MIL-G-45204, Type II, .000030 Min. thick Gold over .000050 Min. thick Nickel
5	Tin plated in accordance with ASTM B545, .00010 Min. thick Matte Tin over .00010 Min. thick Nickel
6	Tin-Lead plated in accordance with SAE-AMS-P-81728, .00010 Min. thick Tin-Lead over .00010 Min. thick Copper

6. Hardware

X Less Hardware

Hardware is purchased separately (see page 59 for hardware options).

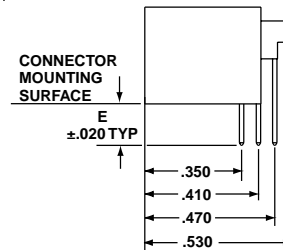
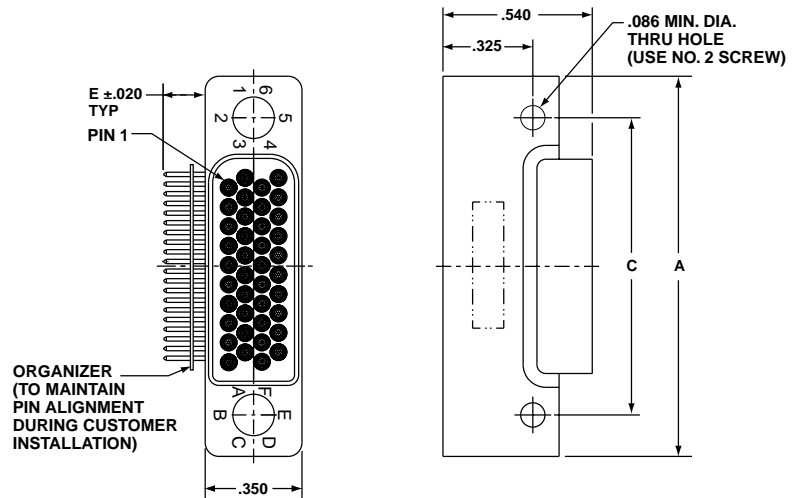

Daughter Board Layout

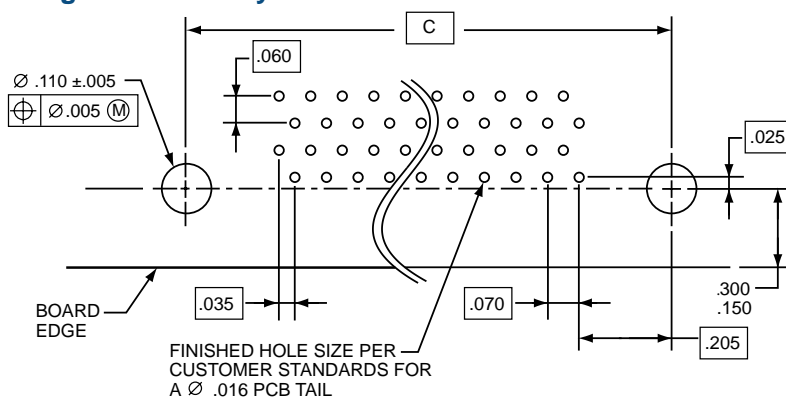

Mated Height Dimensions

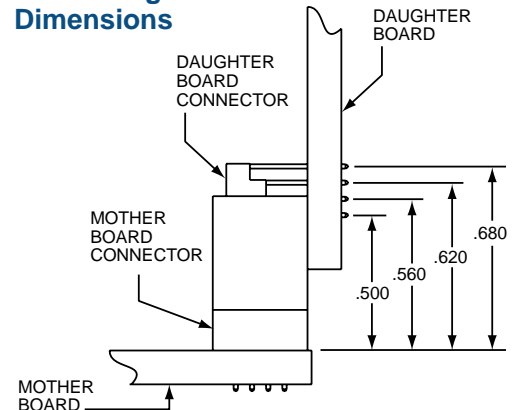

Introduction/
Pkg. Solutions/
Brush Contact

LRM (Line Replaceable Modules)
Staggered/ Hybrids - Fiber Optics/
GEN-X

Hi Speed/RF/Power

Options/
Accessories

Ruggedized
VITA 64x/
VITA 60, 66

High Density
HDB³
HSB³
Hi Speed

Low Mating Force MIL-DTL-55302
Standard Hybrids - Signal/Power/
Brush Cook/Fiber Optics

Docking Conn./
Accessories/Install.

Rack & Panel
Brush
Ruggedized

UMD/LMS
Rectangular
Interconnects

Other
Rectangular
Interconnects

Introduction/
Pkg. Solutions/
Brush Contact

LRM (Line Replaceable Modules)

Options/
Accessories

Ruggedized
VME64x/
VITA 60, 66

High Density
HSB³
Hi Speed

Low Mating Force MIL-DTL-55302

Rack & Panel
Brush
Ruggedized

LMD/LMS
Rectangular
Interconnects

Other
Rectangular
Interconnects

HDB³ I/O APPLICATIONS

- Cable to board applications
- Crimp termination
- Uses wire well size 22D

HDB³ I/O - HOW TO ORDER

Mates with:

- Standard Mother Board

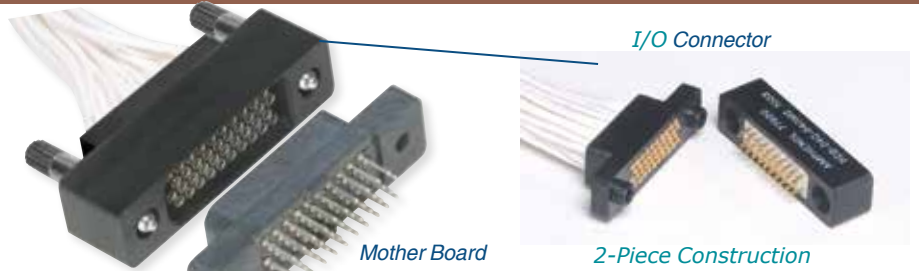

1. Connector Type

HDB-D4C

Designates HDB³ I/O Connector

1.	2.	3.	4.
Connector Type	Number of Contacts	Brush Wire Plating	Contact Termination Finish
HDB-D4C	-120	C	2

2. Number of Contacts

Number of Contacts	Dimension A	Dimension C
040	1.375	1.075
060	1.725	1.425
080	2.075	1.775
120	2.775	2.475
160	3.475	3.175

3. Brush Wire Plating

M	0.000050 Au Min. thick over Nickel
C	0.000020 Au Min. thick over Nickel

4. Contact Termination Finish

2	Gold plated in accordance with MIL-G-45204, Type II, .000030 Min. thick Gold over .000050 Min. thick Nickel
---	---

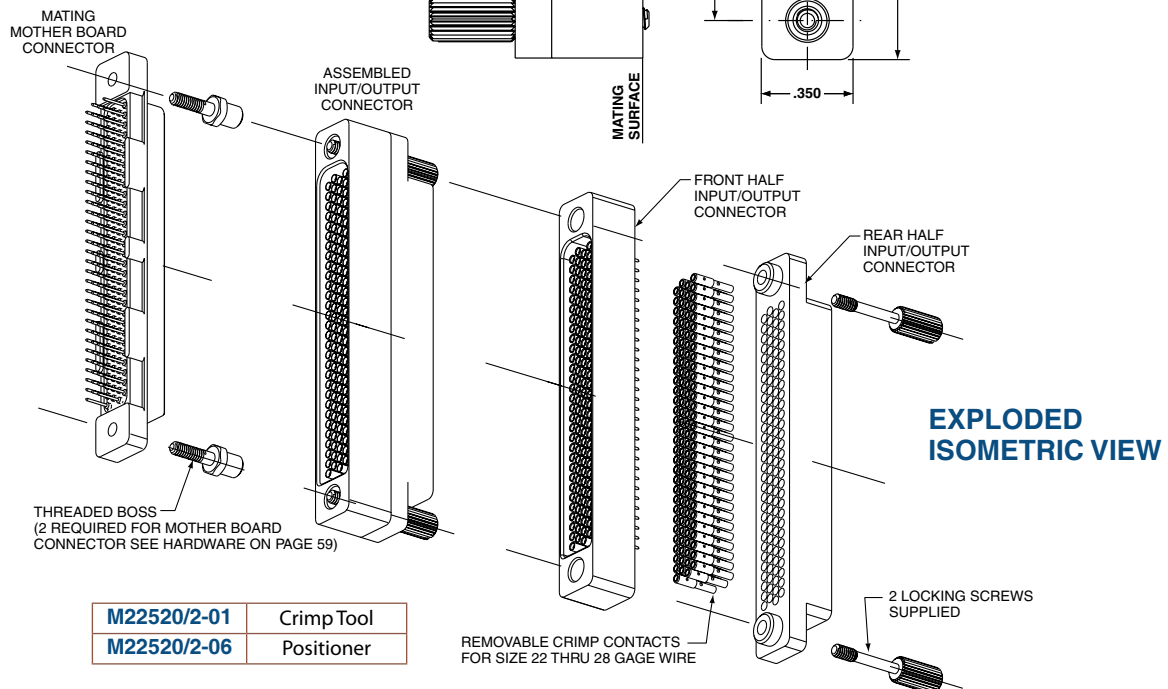
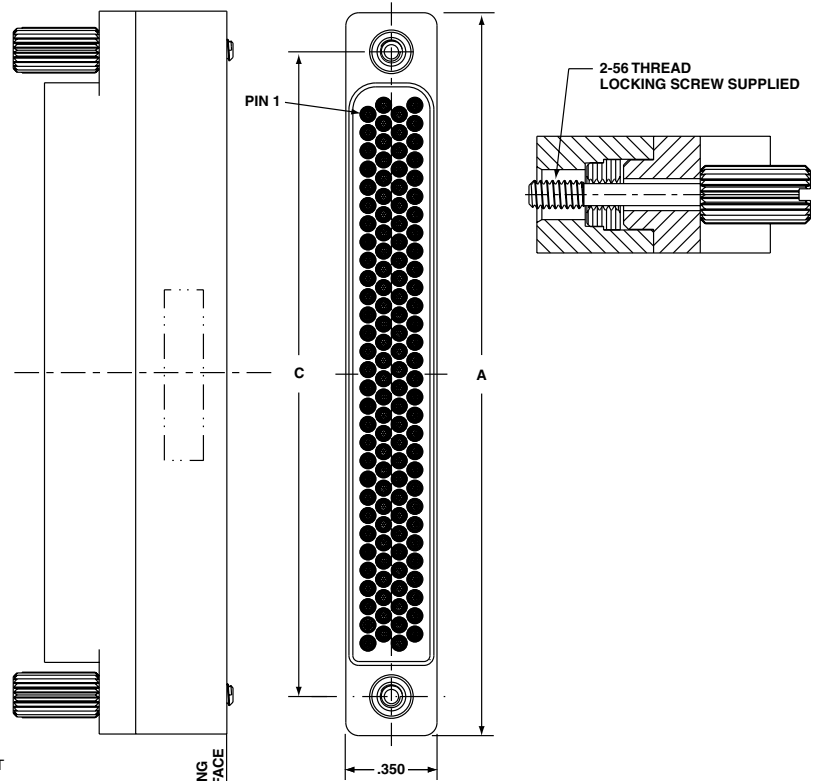

M22520/2-01	Crimp Tool
M22520/2-06	Positioner

DIMENSIONAL DRAWING & HOW TO ORDER

HDB³ STACKER APPLICATIONS

For applications that need or demand parallel boards

HDB³ STACKER - HOW TO ORDER

Mates with:

- Standard Mother Board

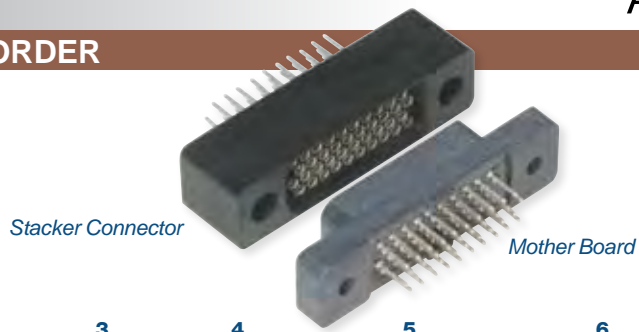

1. Connector Type

HDB-D4S

Designates HDB³ Stacker Connector

	1.	2.	3.	4.	5.	6.
	Number of Contacts	Brush Wire Plating	Termination	Contact Termination Finish	Required Field	
HDB-D4S	120	C	22	2	X	

2. Number of Contacts

Number Diff Signals	Number of Contacts	Dimension A	Dimension C
040	40	1.375	1.075
060	60	1.725	1.425
080	80	2.075	1.775
120	120	2.775	2.475
160	160	3.475	3.175

3. Brush Wire Plating

M	0.000050 Au Min. thick over Nickel
C	0.000020 Au Min. thick over Nickel

4. Termination

	Type	Stickout (Dim. E) ±.020
22	PCB, Straight, .016 Dia	0.100
23	PCB, Straight, .016 Dia	0.130
24	PCB, Straight, .016 Dia	0.160
28	PCB, Straight, .016 Dia	0.280

5. Contact Termination Finish

2	Gold plated in accordance with MIL-G-45204, Type II, .000030 Min. thick Gold over .000050 Min. thick Nickel
----------	---

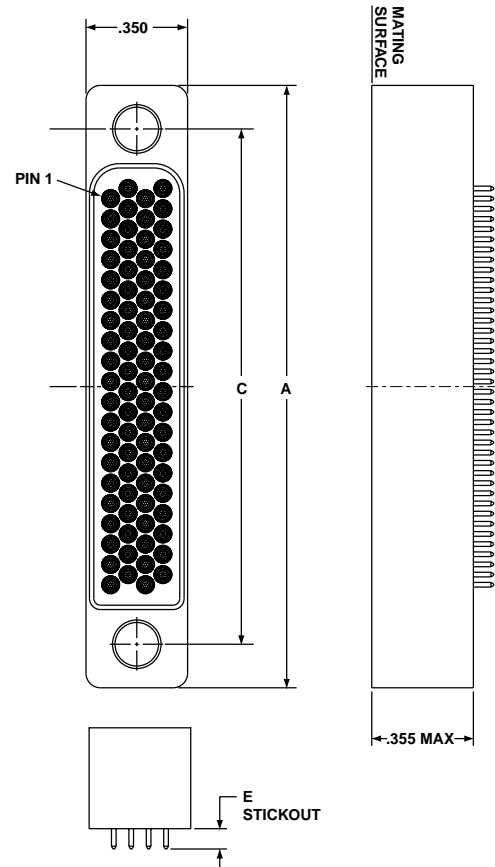

EXPLODED ISOMETRIC VIEW

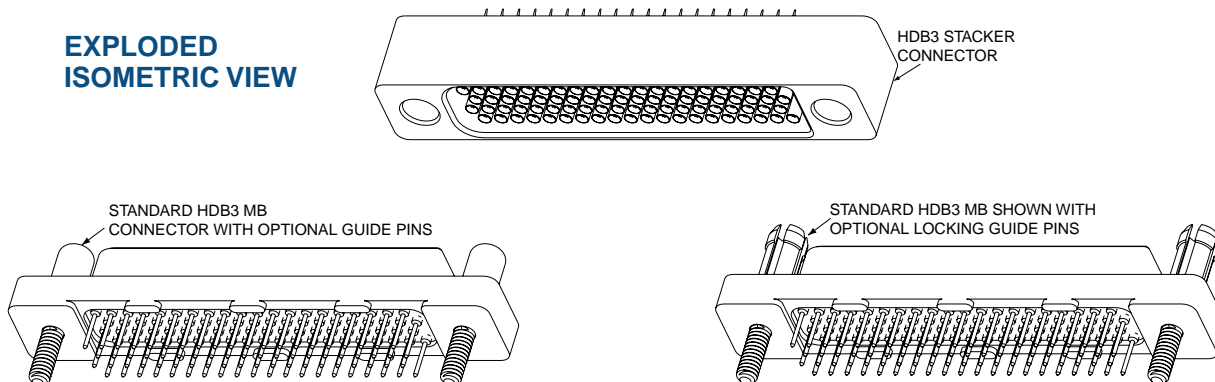

Introduction/
Pkg. Solutions/
Brush Contact

LRM (Line Replaceable Modules)
Staggered/
GEN-X

Hybrids - Fiber Optics/
Hi Speed/RF/Power

Options/
Accessories

Ruggedized
VME 64x/
VITA 60, 66

High Density
HDB³
HSB³
Hi Speed

Low Mating Force MIL-DTL-55302
Standard Brush
Hybrids - Signal/Power/
Cook/Fiber Optics

Docking Conn./
Accessories/Install.

Rack & Panel
Brush
Ruggedized

UMD/LMS
Rectangular
Interconnects

Other
Rectangular
Interconnects

Introduction/
Pkg. Solutions/
Brush Contact

LRM (Line Replaceable Modules)
Options - Fiber Optics / Staggered/
GEN-X

Options/
Accessories
Hi Speed/RF/Power

Ruggedized
VME64x/
VITA 60, 66

High Density
HSB³
Hi Speed

Low Mating Force MIL-DTL-55302
Docking Conn./
Accessories/Install.

Rack & Panel
Brush
Ruggedized

LMD/LMS
Rectangular
Interconnects

Other
Rectangular
Interconnects

HSB³ - HIGH SPEED SERIES 6.250 GBS

High speed configuration available that allows data rates up to 6.250 Gb/s via 100 ohm matched impedance differential pairs.

- Partially populated standard HDB³ mother board and daughter board bodies
- Contact an Amphenol sales engineer for validation results

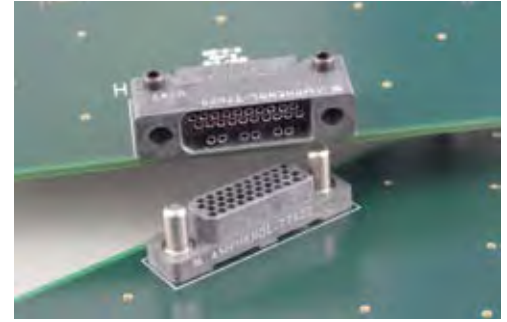

HSB³ HIGH SPEED MOTHER BOARD - HOW TO ORDER

Mates with:

- High Speed Daughter Board

1. Connector Type

HSB-M4

Designates High Speed HDB³ I/O Connector

	1.	2.	3.	4.	5.	6.	7.
		Number of Differential Pairs	Differential Signal	Brush Wire Plating	Termination	Contact Termination Finish	Less Hardware (Purchased separately see pg XX for hardware options)
HSB-M4	HSB-M4	-03	D	M	24	2	X

2. Number of Contacts

Number Differential Pairs	No. Low Speed Signals	Dimension A	Dimension C
03	20	1.375	1.075
05	30	1.725	1.425
07	40	2.075	1.775
10	60	2.775	2.475
13	80	3.475	3.175

3. Differential Signal

D	Standard
----------	----------

4. Brush Wire Plating

M	0.000050 Au Min. thick over Nickel
C	0.000020 Au Min. thick over Nickel

5. Termination

	Type	Stickout (Dim. E)
22	PCB, Straight, .016 Dia	0.120
23	PCB, Straight, .016 Dia	0.150
24	PCB, Straight, .016 Dia	0.180
26	PCB, Straight, .016 Dia	0.240
28	PCB, Straight, .016 Dia	0.300

6. Contact Termination Finish

2	Gold plated in accordance with MIL-G-45204, Type II, .000030 Min. thick Gold over .000050 Min. thick Nickel
5	Tin plated in accordance with ASTM B545, .00010 Min. thick Matte Tin over .00010 Min. thick Nickel
6	Tin-Lead plated in accordance with SAE-AMS-P-81728, .00010 Min. thick Tin-Lead over .00010 Min. thick Copper

7. Hardware

X	Less Hardware
----------	---------------

Hardware is purchased separately (see page 59 for hardware options).

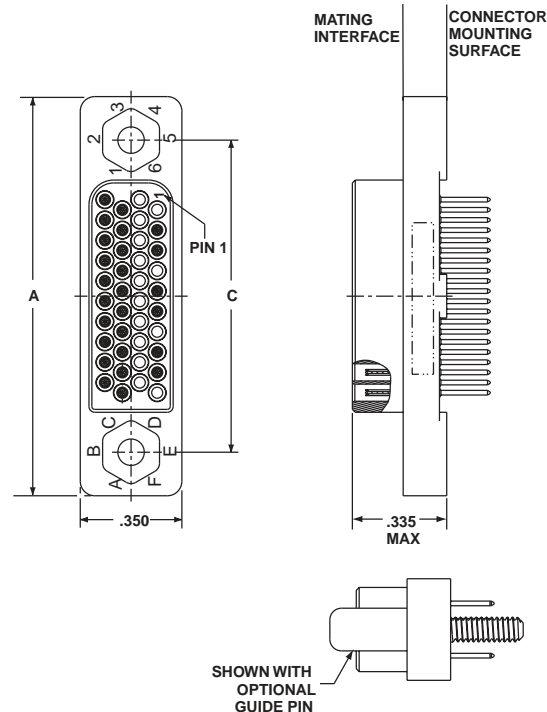

DIMENSIONAL DRAWING & HOW TO ORDER

HSB³ HIGH SPEED DAUGHTER BOARD - HOW TO ORDER

Mates with:

- High Speed Mother Board

	1.	2.	3.	4.	5.	6.	7.
	Number of Differential Pairs	Differential Signals	Brush Wire Plating	Termination	Contact Termination Finish	Less Hardware (Purchased separately see pg 10 for hardware options)	
HSB-D4	-03	D	M	02	2	X	

1. Connector Type

HSB-D4

Designates High Speed HSB³ Daughter Board

2. Number of Contacts

Number Diff Pairs	No. Low Speed Signals	Dimension A	Dimension D
03	20	1.375	1.075
05	30	1.725	1.425
07	40	2.075	1.775
10	60	2.775	2.475
13	80	3.475	3.175

3. Differential Signals

D	Standard
----------	----------

4. Brush Wire Plating

M	0.000050 Au Min. thick over Nickel
C	0.000020 Au Min. thick over Nickel

5. Termination

	Type	Stickout (Dim. E)
01	PCB, Right Angle, .016 Dia	0.090
02	PCB, Right Angle, .016 Dia	0.120
03	PCB, Right Angle, .016 Dia	0.150
04	PCB, Right Angle, .016 Dia	0.180
06	PCB, Right Angle, .016 Dia	0.300

6. Contact Termination Finish

2	Gold plated in accordance with MIL-G-45204, Type II, .000030 Min. thick Gold over .000050 Min. thick Nickel
5	Tin plated in accordance with ASTM B545, .00010 Min. thick Matte Tin over .00010 Min. thick Nickel
6	Tin-Lead plated in accordance with SAE-AMS-P-81728, .00010 Min. thick Tin-Lead over .00010 Min. thick Copper

7. Hardware

X	Less Hardware
----------	---------------

Hardware is purchased separately (see page 59 for hardware options).

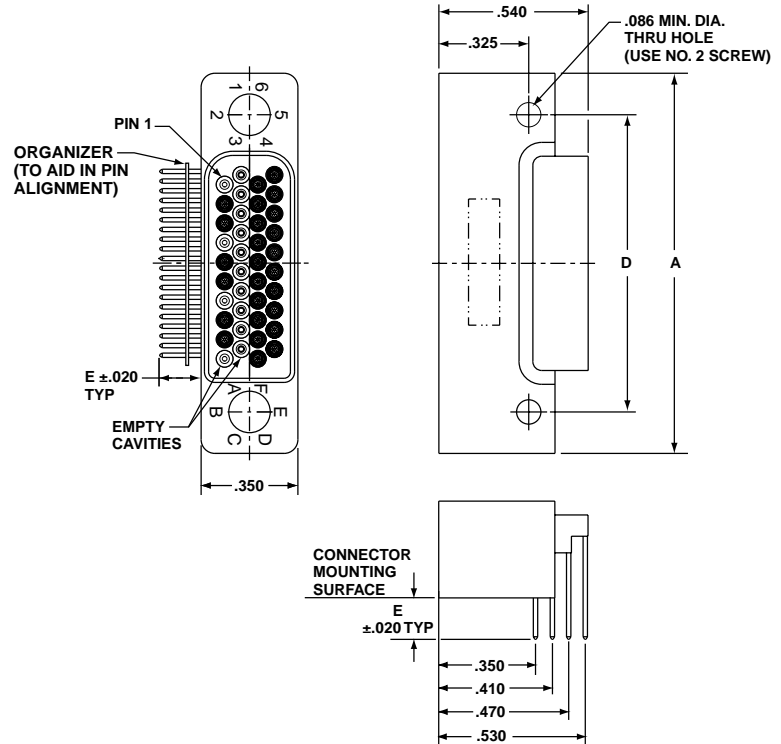

Introduction/
Pkg. Solutions/
Brush Contact

LRM (Line Replaceable Modules)
Staggered/ Hybrids - Fiber Optics/
GEN-X

Options/
Accessories

Ruggedized
VME 64x/
VITA 60, 66

High Density
HSB³
HSB³
Hi Speed

Low Mating Force MIL-DTL-55302
Standard Brush
Hybrids - Signal/Power/
Coax/Fiber Optics

Docking Conn./
Accessories/Install.

Rack & Panel
Brush
Ruggedized

LRM/LMS
Rectangular
Interconnects

Other
Rectangular
Interconnects

ARRANGEMENTS

Introduction/
Pkg. Solutions/
Brush Contact

LRM (Line Replaceable Modules)
Options/
Accessories

Hybrids - Fiber Optics/
Hi Speed/RF/Power

Staggered/
GEN-X

Ruggedized
VME64x/
VITA 60, 66

High Density
HSB³
Hi Speed

HDB³

Low Mating Force MIL-DTL-55302
Docking Conn./
Accessories/Install.

Hybrids - Signal/Power/
Coax/Fiber Optics

Standard
Brush

Rack & Panel
Brush
Ruggedized

LMD/LMS
Rectangular
Interconnects

Other
Rectangular
Interconnects

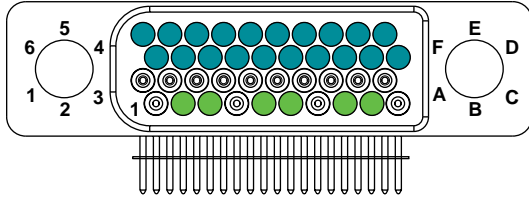

40 Pin Body with 3 Differential Pair, 20 Signal Contacts

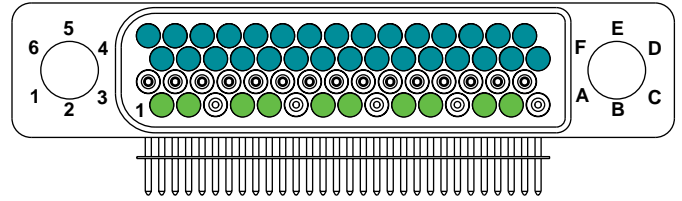

60 Pin Body with 5 Differential Pair, 30 Signal Contacts

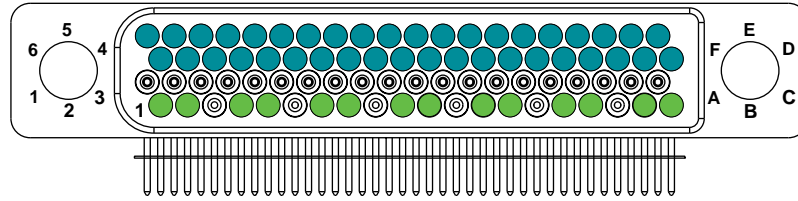

80 Pin Body with 7 Differential Pair, 40 Signal Contacts

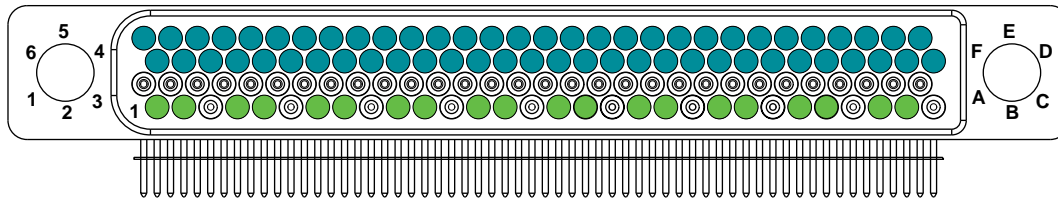

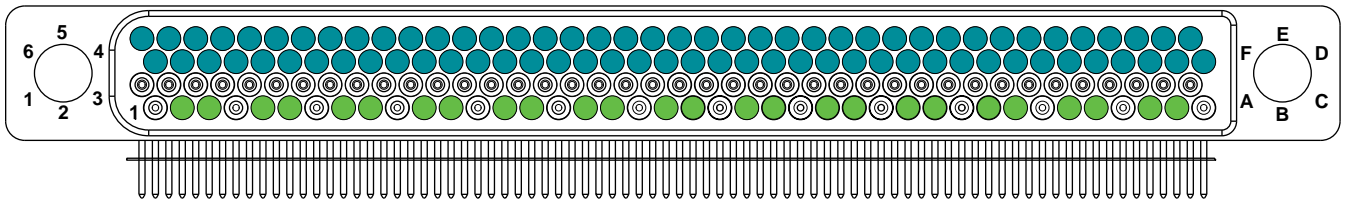

120 Pin Body with 10 Differential Pair, 60 Signal Contacts



160 Pin Body with 13 Differential Pair, 80 Signal Contacts

KEY

-  100 Ohm Differential Pair Contacts
(100 Ohm Differential contact pairs capable of 6.250 Gb/s data rates)
-  Empty Contact Cavity
-  Standard Digital, Low Speed Signal Contacts

As viewed from front of daughter board connector

RECOMMENDED BOARD LAYOUT - HSB³ DAUGHTER BOARD

HSB³ DAUGHTER BOARD

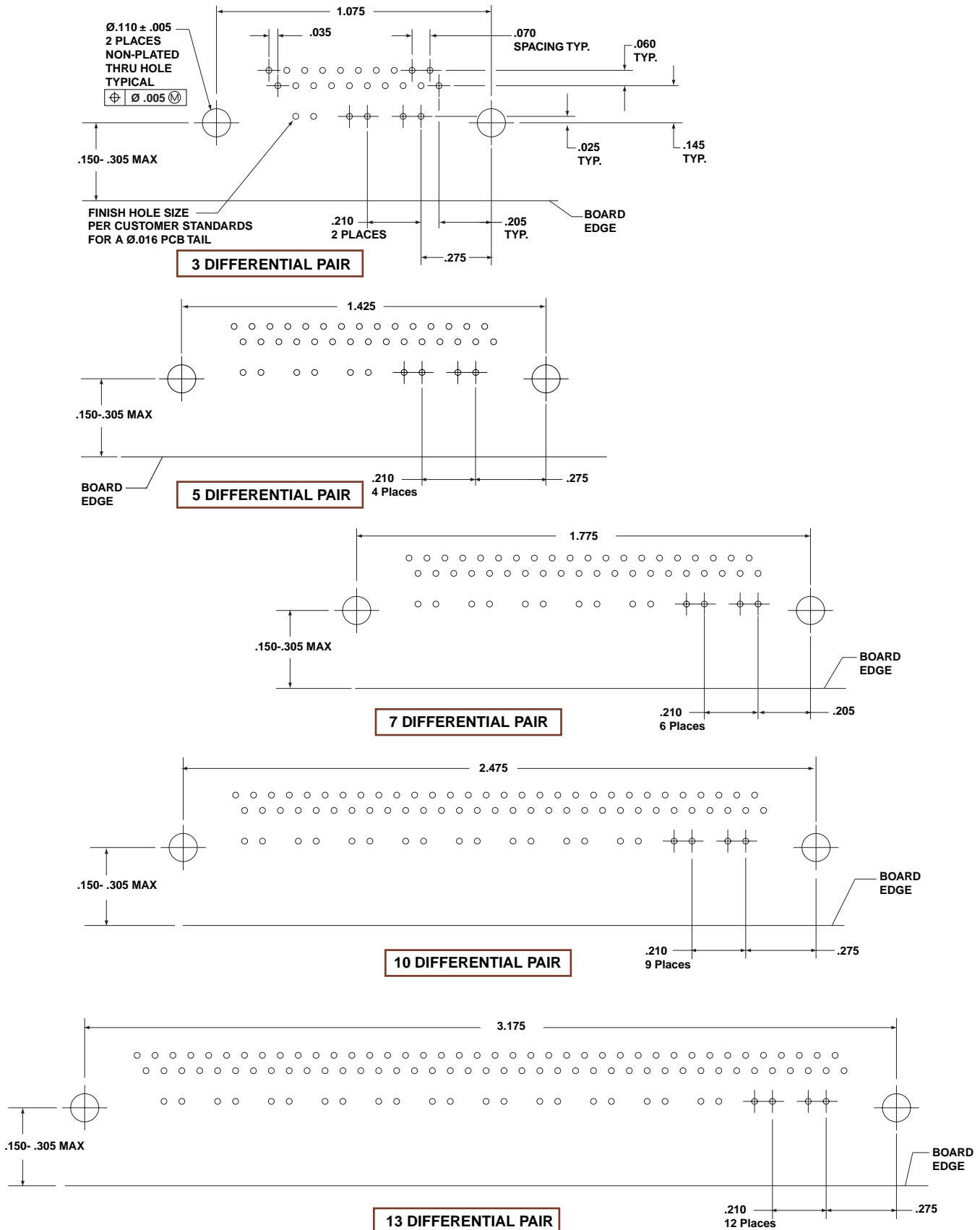

- Introduction/
Pkg. Solutions/
Brush Contact
- LRM (Line Replaceable Modules)
- Staggered/
GEN-X
- Hybrids - Fiber Optics/
Hi Speed/RF/Power
- Options/
Accessories
- Ruggedized
VME 64x/
VITA 60, 66
- High Density
HSB³
HSB³
Hi Speed
- Low Mating Force MIL-DTL-55302
Standard | Hybrids - Signal/Power/
Brush
Cook/Fiber Optics
- Docking Conn./
Accessories/Install.
- Rack & Panel
Brush
Ruggedized
- UMD/LMS
Rectangular
Interconnects
- Other
Rectangular
Interconnects

Introduction/
Pkg. Solutions/
Brush Contact

LRM (Line Replaceable Modules)
Options/
Accessories

Ruggedized
VME64x/
VITA 60, 66

High Density
HSB³
Hi Speed

Low Mating Force MIL-DTL-55302
Docking Conn./
Accessories/Install.

Rack & Panel
Brush
Ruggedized

LMD/LMS
Rectangular
Interconnects

Other
Rectangular
Interconnects

HSB³ MOTHER BOARD

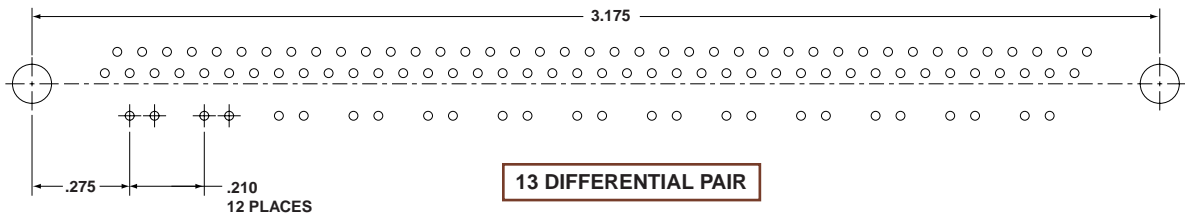
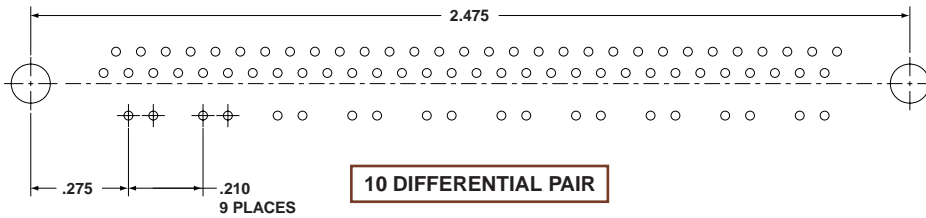
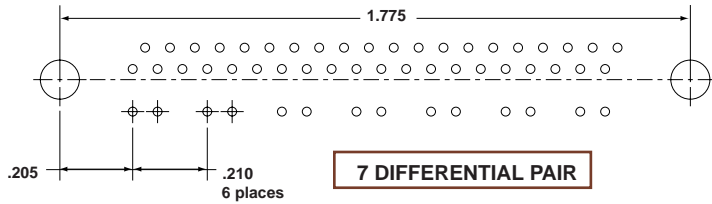
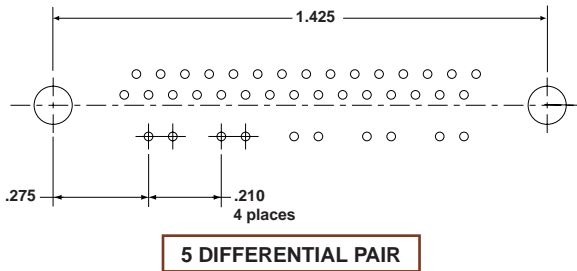
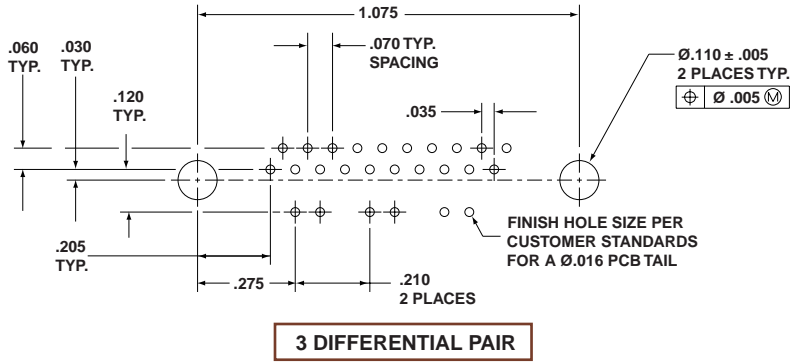

HARDWARE FOR BOTH HDB³ AND HSB³

HARDWARE FOR ALL CONFIGURATIONS (Sold Separately)

Each connector requires (2) of the component hardware listed below. These components are sold as individual units.

MOTHER BOARD			
PART NUMBER	TYPE	STICKOUT	
HDB-508803-001	POLARIZATION KEY	0.250	
HDB-508803-002	POLARIZATION KEY	0.500	
HDB-508803-003	POLARIZATION KEY	0.750	
HDB-508802-001	GUIDE PIN	0.250	
HDB-508802-002	GUIDE PIN	0.500	
HDB-508802-003	GUIDE PIN	0.750	
HDB-508808-001	THREADED BOSS*	0.250	
HDB-508808-002	THREADED BOSS*	0.500	
HDB-508808-003	THREADED BOSS*	0.750	
HDB-508808-020	LOCKING GUIDE PIN	0.250	
HDB-508808-021	LOCKING GUIDE PIN	0.500	
HDB-508808-022	LOCKING GUIDE PIN	0.750	

Accepts
I/O Connector
Jack Screw

Shown with
Mother Board
Connector on page 53

* Required with Mother Board only when mating to I/O Connector

DAUGHTER BOARD		
PART NUMBER	TYPE	
HDB-508804-000	POLARIZATION KEY	
HDB-508804-001	LOW PROFILE MOUNTING NUT	

EXPLODED ISOMETRIC VIEW

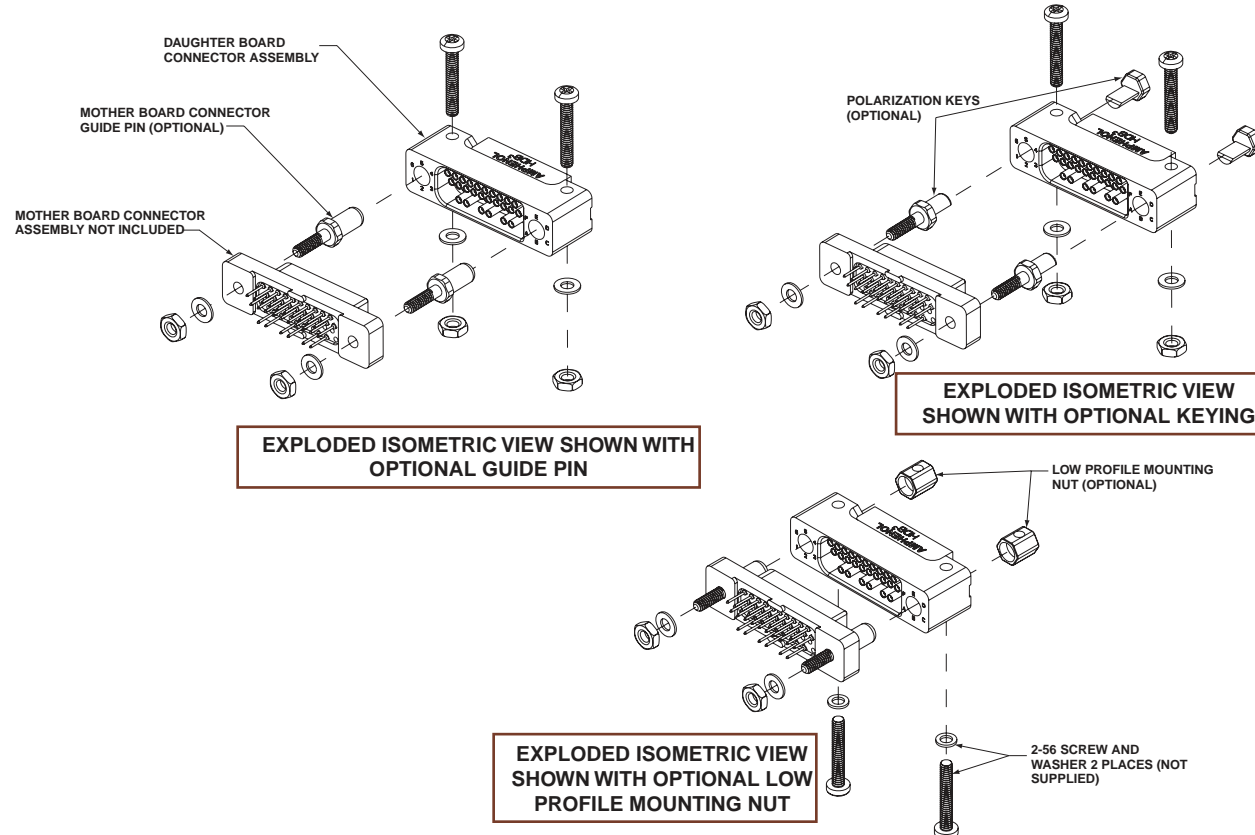

Introduction/
Pkg. Solutions/
Brush Contact

LRM (Line Replaceable Modules)

Staggered/
GEN-X

Hybrids - Fiber Optics/
Hi Speed/RF/Power

Options/
Accessories

Ruggedized
VME 64x/
VITA 60, 66

High Density
HDB³ | HSB³
Hi Speed

Low Mating Force MIL-DTL-55302
Standard | Hybrids - Signal/Power/
Brush | Cook/Fiber Optics

Docking Conn./
Accessories/Install.

Rack & Panel
Brush
Ruggedized

UMD/LMS
Rectangular
Interconnects

Other
Rectangular
Interconnects

X-ON Electronics

Largest Supplier of Electrical and Electronic Components

Click to view similar products for [Rectangular MIL Spec Connectors](#) category:

Click to view products by [Amphenol](#) manufacturer:

Other Similar products are found below :

[891-011-15SA2-BSST](#) [CTS-S16/16](#) [65002-062](#) [CY4602-000](#) [732-8020-01](#) [77058-22-55PN](#) [81542-20](#) [86.030.0053.0](#) [1241346-1](#) [RM252-020-311-2900](#) [DMC-M 08-16 SA](#) [1589051-4](#) [MSO34MPK1E1](#) [BACC65CAMA](#) [BACC65CP1PN](#) [BACI10BC0816PNBA](#) [HSB-D4S03DM222X](#) [2217548-1](#) [891-006-9PS-BST1T](#) [891-009-15SA2-BRT1T](#) [27963-20T12](#) [SIM2S100A](#) [1604996-2](#) [SMD25PN90L-4055](#) [1900ND08S1B00A](#) [22628-10-6P-791](#) [33526M11-08PD](#) [RE04-212S](#) [M32139/03-G05SN](#) [CTD160E01F-6148](#) [CTJ112E03B](#) [CTJ122E02D-8000](#) [CTJ-3D-12](#) [CTJ920E06N-513](#) [CTJ920E12N-513](#) [CTL-16-090](#) [RM300-000-581-0000](#) [CY4600-000](#) [CY4601-000](#) [38111-14-15SN](#) [38112-14-15PN](#) [MMA23-0111R1](#) [MMD25-0071P1](#) [33516062020](#) [33526M11-08PE](#) [DMC-M99-01AN](#) [Y59113WE20PNV00300](#) [ZPF000000000106310](#) [105979-31](#) [EN4165M01AD0G0](#)