

PART NUMBER	DIM A	DIM B
7840-001	5.20	4.30
7840-002	12.20	11.30
7840-003	23.62	22.72
7840-101	5.20	4.30
7810-102	12.20	11.30

DRAWING CREATED WITH SW

REVISIONS			
REV	DESCRIPTION	DATE	DWN
9	EC-12781 UPDATED TO MATCH INSP REV. LEVEL	3/1/18	GQ

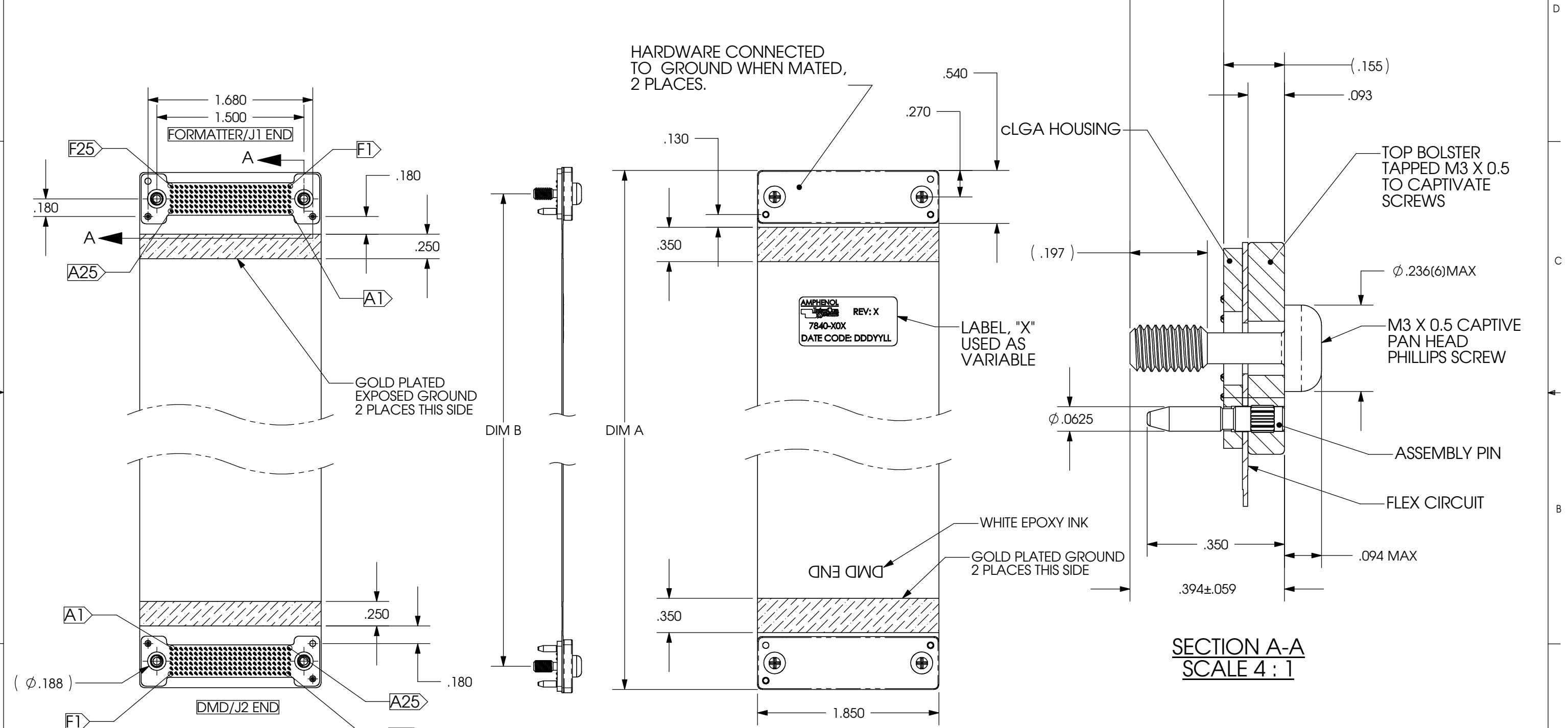

SECTION A-A
SCALE 4:1

CLGA CONTACTS
NOT SHOW THIS PAGE
FOR CLARITY



THIS DOCUMENT CONTAINS PROPRIETARY INFORMATION OF AMPHENOL INTERCON SYSTEMS AND MAY NOT BE DISCLOSED, REPRODUCED OR OTHERWISE USED WITHOUT WRITTEN PERMISSION

ALL DIMENSIONS AND TOLERANCES PER ASME Y14.5M-1994	THIRD ANGLE PROJECTION
INSPECTION	TOLERANCES UNLESS SPECIFIED OTHERWISE
◇ FIRST PIECE	2PLC ± .010
△ SPC	3PLC ± .005
○ IN-PROCESS	4PLC ± .002
	ANGLES ± 1°
MATERIAL	FINISH

Amphenol Inter-Con Systems		AMPHENOL INTERCON SYSTEMS INC. ETTERS, PA 17319	
NAME CSTACK SYSTEM, FLEX ASSEMBLY & BOLSTER PLATE, 150 POSITION			
SIZE B	PROD CODE 043	DRAWING NUMBER C - 7840	REV 9
SCALE 1:1	CUSTOMER		SHEET 1 OF 5

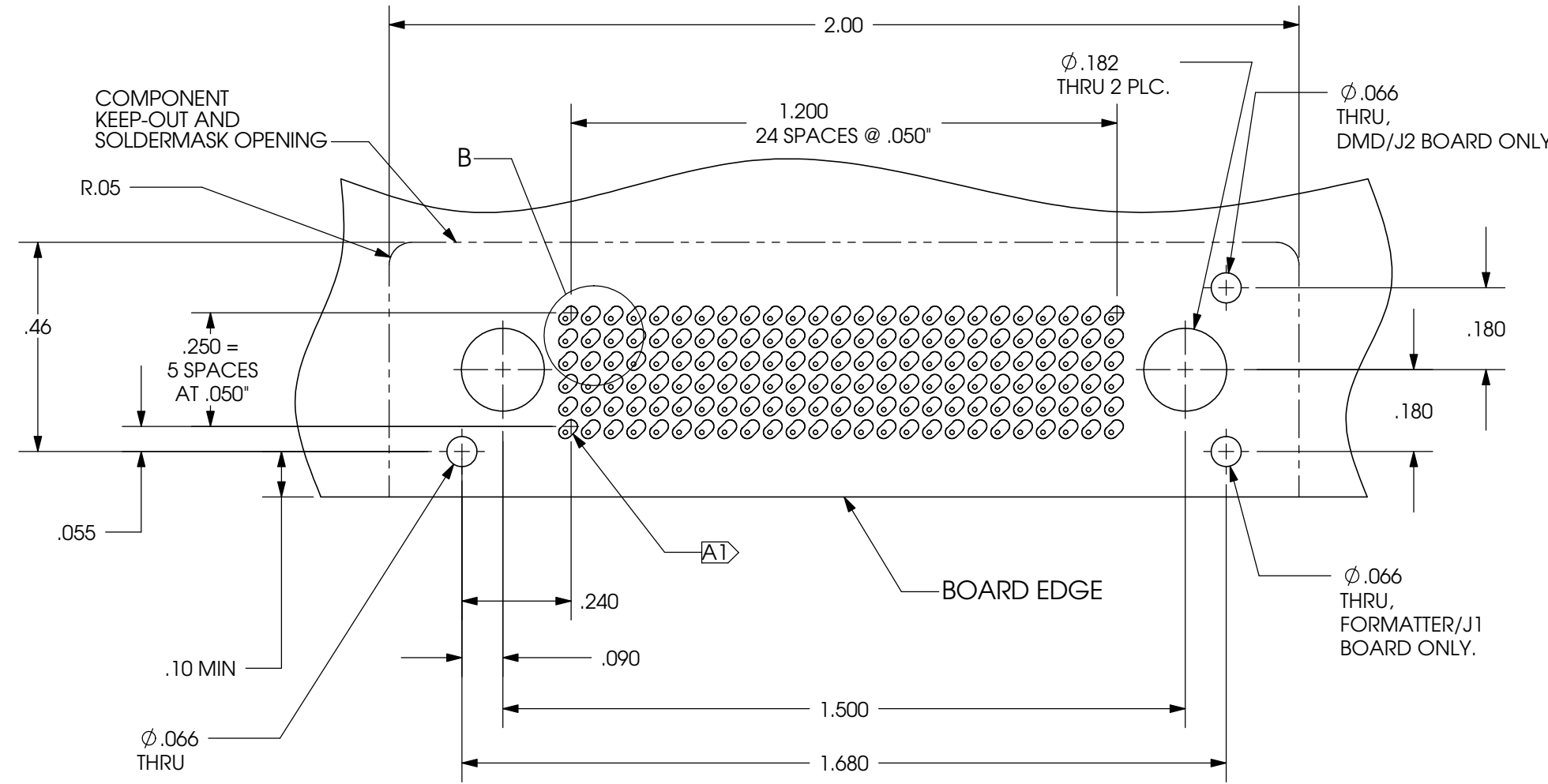

RECOMMENDED P.C. BOARD LAYOUT
ALL .XXX DIMENSIONS ±.003" UNLESS OTHERWISE INDICATED

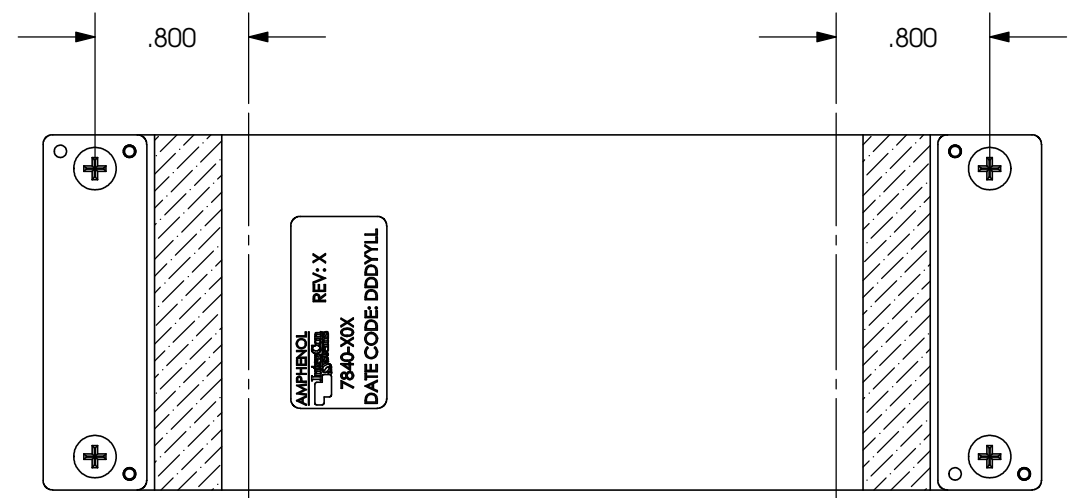
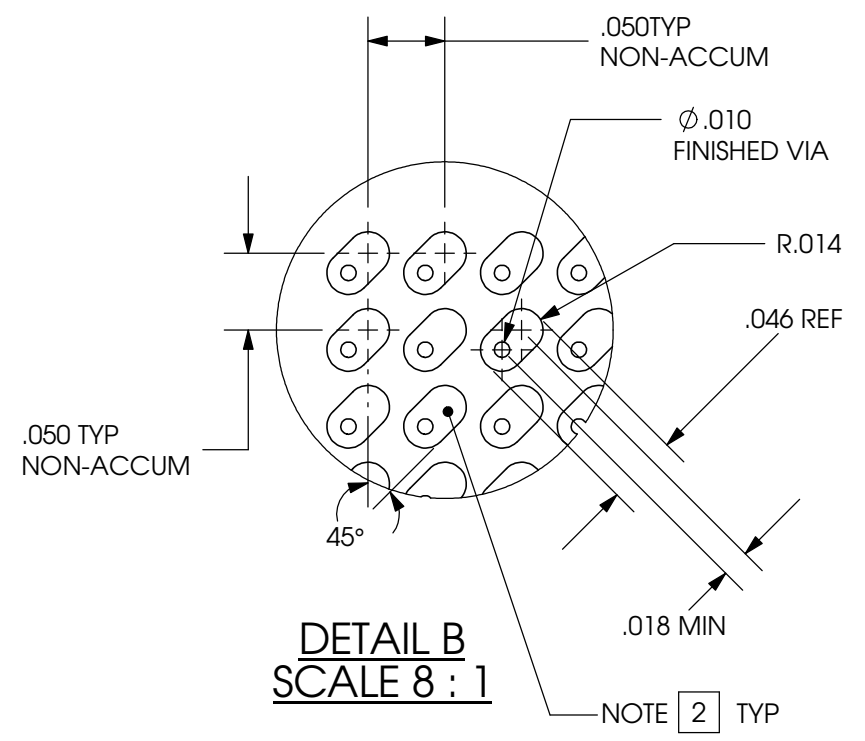

BEND REQUIREMENTS
SCALE 1:1
 NOTE [6]



THIS DOCUMENT CONTAINS PROPRIETARY INFORMATION OF AMPHENOL INTERCON SYSTEMS AND MAY NOT BE DISCLOSED, REPRODUCED OR OTHERWISE USED WITHOUT WRITTEN PERMISSION

ALL DIMENSIONS AND TOLERANCES PER ASME Y14.5M-1994	THIRD ANGLE PROJECTION
INSPECTION	TOLERANCES UNLESS SPECIFIED OTHERWISE
◇ FIRST PIECE	2PLC ± .010
△ SPC	3PLC ± .005
○ IN-PROCESS	4PLC ± .002
	ANGLES ± 1°
MATERIAL	FINISH

AMPHENOL INTERCON SYSTEMS INC. ETTERS, PA 17319	
NAME	
cSTACK SYSTEM, FLEX ASSEMBLY & BOLSTER PLATE, 150 POSITION	
SIZE	PROD CODE
B	043
DRAWING NUMBER	REV
C - 7840	9
SCALE	CUSTOMER
3:1	
SHEET	OF
2	5

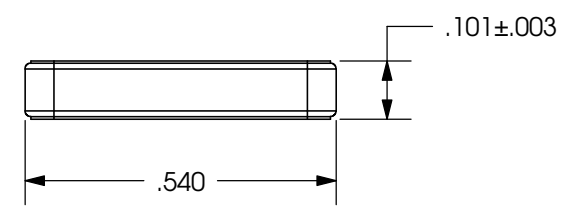
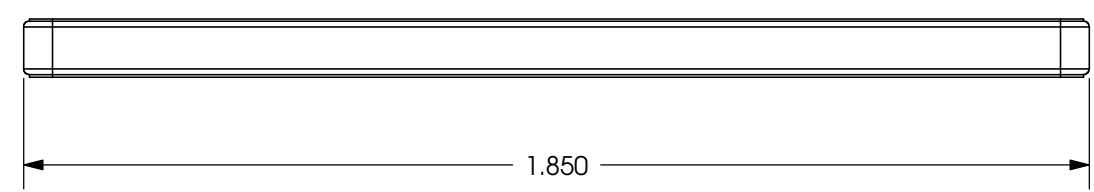
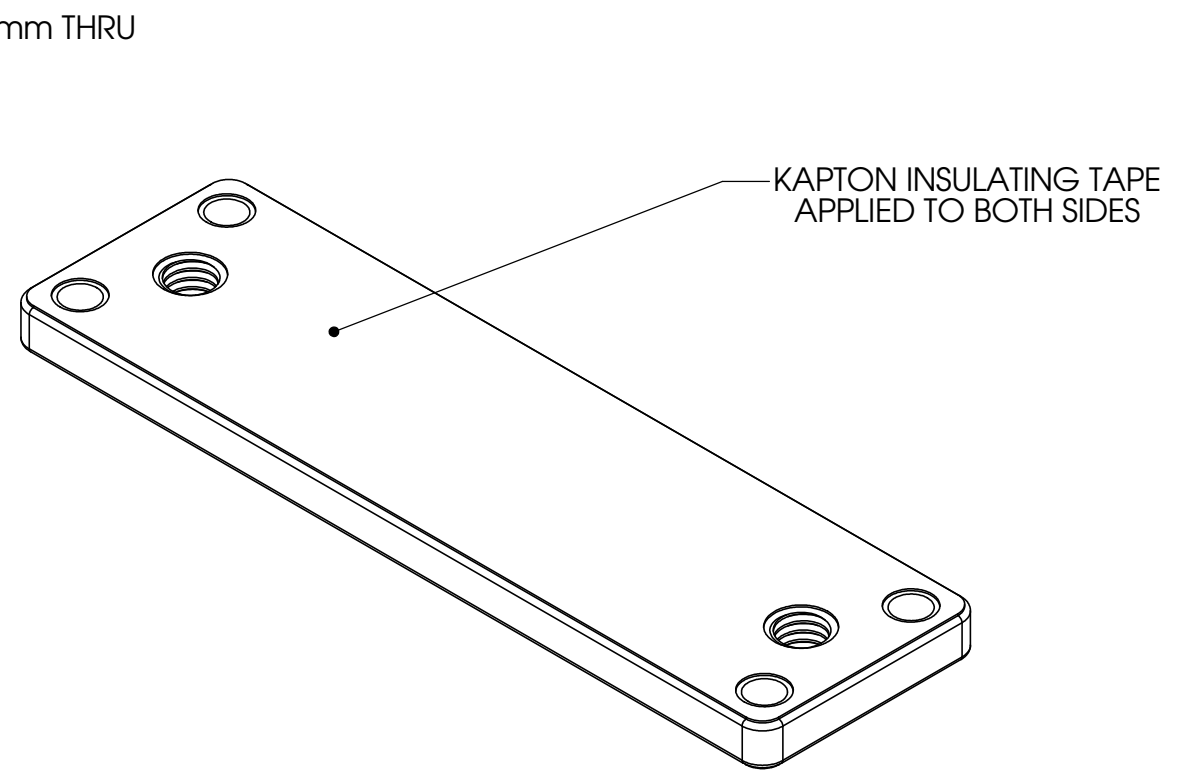
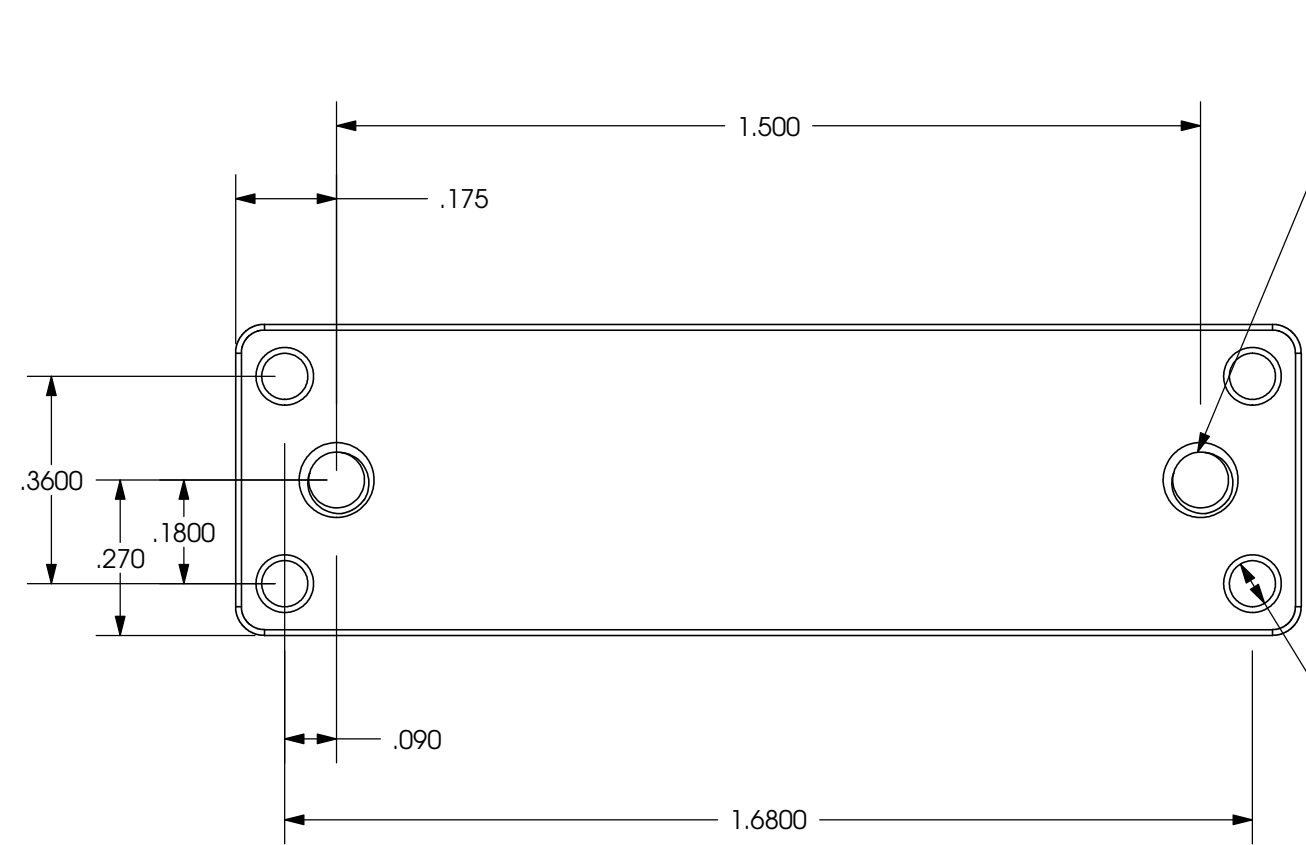

PCB BOLSTER ASSEMBLY

8



THIS DOCUMENT CONTAINS PROPRIETARY INFORMATION OF AMPHENOL INTERCON SYSTEMS AND MAY NOT BE DISCLOSED, REPRODUCED OR OTHERWISE USED WITHOUT WRITTEN PERMISSION

ALL DIMENSIONS AND TOLERANCES PER ASME Y14.5M-1994	THIRD ANGLE PROJECTION
INSPECTION	TOLERANCES UNLESS SPECIFIED OTHERWISE
◇ FIRST PIECE	2PLC ± .010
△ SPC	3PLC ± .005
○ IN-PROCESS	4PLC ± .002
	ANGLES ± 1°
MATERIAL <input type="checkbox"/>	FINISH <input type="checkbox"/>

		AMPHENOL INTERCON SYSTEMS INC. ETTERS, PA 17319	
NAME			
CSTACK SYSTEM, FLEX ASSEMBLY & BOLSTER PLATE, 150 POSITION			
SIZE	PROD CODE	DRAWING NUMBER	REV
B	043	C - 7840	9
SCALE	CUSTOMER		SHEET
1:1			3 OF 5

NETLIST:

NET	PIN	PIN
DDAP13	J1.A02	J2.E24
DDAP9	J1.A04	J2.E22
DDAP7	J1.A06	J2.E20
DDAP3	J1.A08	J2.E18
SCPDO	J1.A10	J2.E16
MBRST15	J1.A12	J2.E14
MBRST10	J1.A14	J2.E12
MBRST13	J1.A16	J2.E10
DDBP3	J1.A18	J2.E08
DDBP7	J1.A20	J2.E06
DDBP9	J1.A22	J2.E04
DDBP13	J1.A24	J2.E02

DDAN13	J1.B02	J2.D24
DDAP11	J1.B03	J2.F23
DDAN9	J1.B04	J2.D22
DCLKAP	J1.B05	J2.F21
DDAN7	J1.B06	J2.D20
DDAP5	J1.B07	J2.F19
DDAN3	J1.B08	J2.D18
DDAP1	J1.B09	J2.F17
SCPCLK	J1.B10	J2.D16
DMDSPARE1	J1.B11	J2.F15
MBRST14	J1.B12	J2.D14
MBRST6	J1.B14	J2.D12
MBRST9	J1.B15	J2.F11
MBRST12	J1.B16	J2.D10
DDBP1	J1.B17	J2.F09
DDBN3	J1.B18	J2.D08
DDBP5	J1.B19	J2.F07
DDBN7	J1.B20	J2.D06
DCLKBP	J1.B21	J2.F05
DDBN9	J1.B22	J2.D04
DDBP11	J1.B23	J2.F03
DDBN13	J1.B24	J2.D02
DDBP15	J1.B25	J2.F01

GROUND	J1.A01	J1.A03
	J1.A05	J1.A07
	J1.A09	J1.A11
	J1.A15	J1.A17
	J1.A19	J1.A21
	J1.A23	J1.A25
	J1.C02	J1.C04
	J1.C06	J1.C08
	J1.C10	J1.C12
	J1.C14	J1.C16
	J1.C18	J1.C20
	J1.C22	J1.C24
	J1.D01	J1.D03
	J1.D05	J1.D07
	J1.D09	J1.D11
	J1.D13	J1.D15

NET	PIN	PIN
DDAN11	J1.C03	J2.E23
DCLKAN	J1.C05	J2.E21
DDAN5	J1.C07	J2.E19
DDAN1	J1.C09	J2.E17
DMDSELZ	J1.C11	J2.E15
MBRST1	J1.C13	J2.F13
MBRST7	J1.C15	J2.E11
DDBN1	J1.C17	J2.E09
DDBN5	J1.C19	J2.E07
DCLKBN	J1.C21	J2.E05
DDBN11	J1.C23	J2.E03
DDBN15	J1.C25	J2.E01

DDAP14	J1.D02	J2.B24
DDAP10	J1.D04	J2.B22
SCTRLAP	J1.D06	J2.B20
DDAP4	J1.D08	J2.B18
DDAP0	J1.D10	J2.B16
DMDSPARE0	J1.D12	J2.B14
MBRST0	J1.D14	J2.B12
DDBP0	J1.D16	J2.B10
DDBP4	J1.D18	J2.B08
SCTRLBP	J1.D20	J2.B06
DDBP10	J1.D22	J2.B04
DDBP14	J1.D24	J2.B02

DMD3P3VA	J1.C01	J1.B01	J2.E25	J2.F25
----------	--------	--------	--------	--------

DMD3P3VB	J1.F25	J1.E25	J2.C01	J2.B01
----------	--------	--------	--------	--------

DMDVCC2	J1.B13	J1.A13	J2.A13	J2.B13
---------	--------	--------	--------	--------

GROUND	J1.D17	J1.D19
	J1.D21	J1.D23
	J1.D25	J1.F02
	J1.F04	J1.F06
	J1.F08	J1.F10
	J1.F12	J1.F14
	J1.F16	J1.F18
	J1.F20	J1.F22
	J1.F24	J2.A01
	J2.A03	J2.A05
	J2.A07	J2.A09
	J2.A11	J2.A15
	J2.A17	J2.A19
	J2.A21	J2.A23
	J2.A25	J2.C02
	J2.C04	J2.C06

NET	PIN	PIN
DDAP15	J1.E01	J2.C25
DDAN14	J1.E02	J2.A24
DDAP12	J1.E03	J2.C23
DDAN10	J1.E04	J2.A22
DDAP8	J1.E05	J2.C21
SCTRLAN	J1.E06	J2.A20
DDAP6	J1.E07	J2.C19
DDAN4	J1.E08	J2.A18
DDAP2	J1.E09	J2.C17
DDAN0	J1.E10	J2.A16
SCPO_DI	J1.E11	J2.C15
MBRST11	J1.E12	J2.A14
MBRST5	J1.E13	J2.E13
MBRST3	J1.E14	J2.A12
MBRST2	J1.E15	J2.C11
DDBN0	J1.E16	J2.A10
DDBP2	J1.E17	J2.C09
DDBN4	J1.E18	J2.A08
DDBP6	J1.E19	J2.C07
SCTRLBN	J1.E20	J2.A06
DDBP8	J1.E21	J2.C05
DDBN10	J1.E22	J2.A04
DDBP12	J1.E23	J2.C03
DDBN14	J1.E24	J2.A02

DDAN15	J1.F01	J2.B25
DDAN12	J1.F03	J2.B23
DDAN8	J1.F05	J2.B21
DDAN6	J1.F07	J2.B19
DDAN2	J1.F09	J2.B17
DMDRSTZ	J1.F11	J2.B15
MBRST4	J1.F13	J2.C13
MBRST8	J1.F15	J2.B11
DDBN2	J1.F17	J2.B09
DDBN6	J1.F19	J2.B07
DDBN8	J1.F21	J2.B05
DDBN12	J1.F23	J2.B03

GROUND	J2.C08	J2.C10
	J2.C12	J2.C14
	J2.C16	J2.C18
	J2.C20	J2.C22
	J2.C24	J2.D01
	J2.D03	J2.D05
	J2.D07	J2.D09
	J2.D11	J2.D13
	J2.D15	J2.D17
	J2.D19	J2.D21
	J2.D23	J2.D25
	J2.F02	J2.F04
	J2.F06	J2.F08
	J2.F10	J2.F12
	J2.F14	J2.F16
	J2.F18	J2.F20
	J2.F22	J2.F24



THIS DOCUMENT CONTAINS PROPRIETARY INFORMATION OF AMPHENOL INTERCON SYSTEMS AND MAY NOT BE DISCLOSED, REPRODUCED OR OTHERWISE USED WITHOUT WRITTEN PERMISSION	
ALL DIMENSIONS AND TOLERANCES PER ASME Y14.5M-1994	THIRD ANGLE PROJECTION
INSPECTION	TOLERANCES UNLESS SPECIFIED OTHERWISE
<ul style="list-style-type: none"> ◇ FIRST PIECE △ SPC ○ IN-PROCESS 	2PLC ± .010 3PLC ± .005 4PLC ± .002 ANGLES ± 1°
MATERIAL <input type="checkbox"/>	FINISH <input type="checkbox"/>

AMPHENOL INTERCON SYSTEMS INC. ETTERS, PA 17319	
NAME	
CSTACK SYSTEM, FLEX ASSEMBLY & BOLSTER PLATE, 150 POSITION	
SIZE	PROD CODE
B	043
DRAWING NUMBER	REV
C - 7840	9
SCALE	SHEET
1:1	4 OF 5

D
C
B
A

D
C
B
A

SHIPPING CONFIGURATION SHOWN

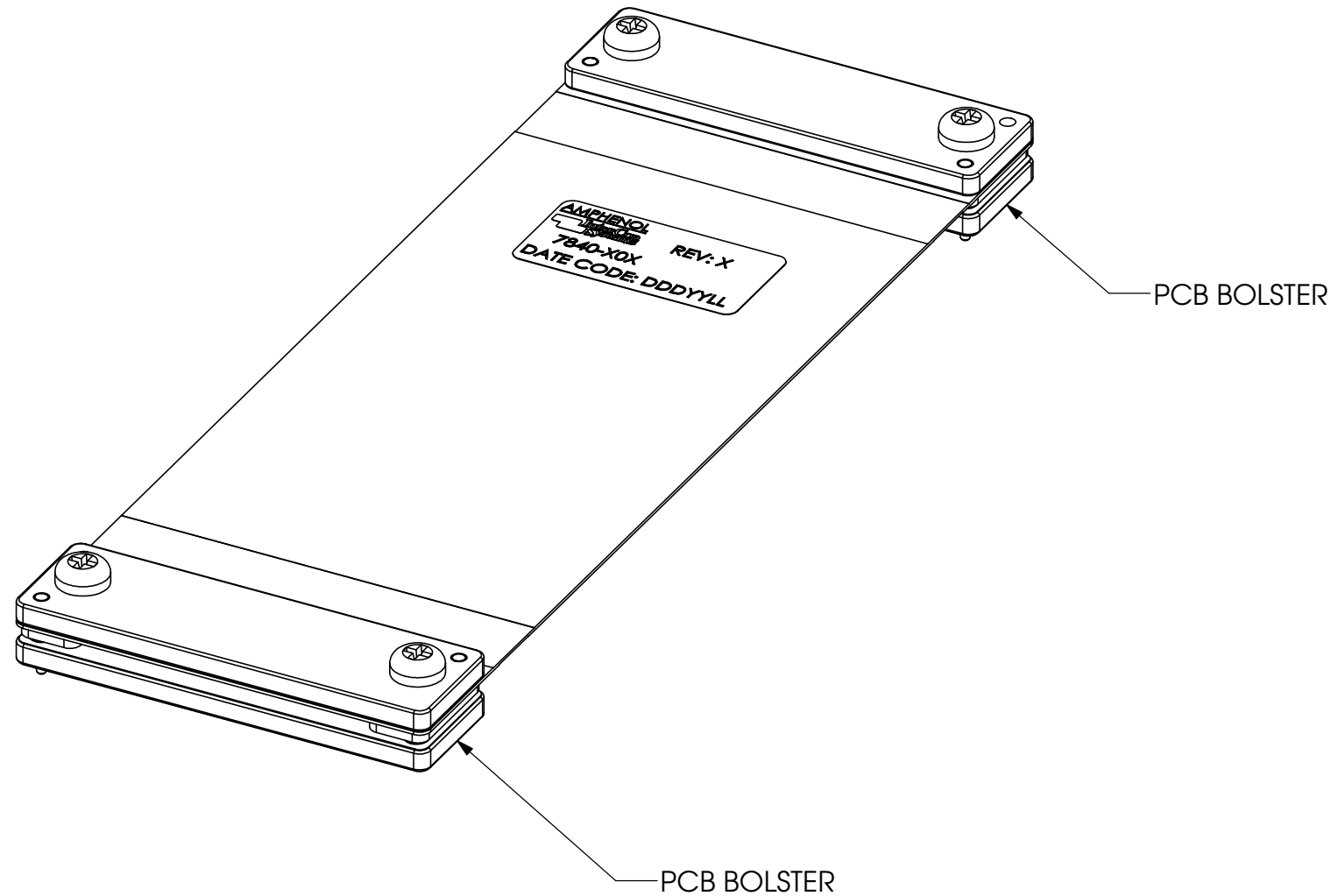

NOTES:

- 1 MATERIALS:
 HOUSING: LIQUID CRYSTAL POLYMER, UL 94 V-0, COLOR: BLACK.
 CONTACT: BERYLLIUM COPPER, .0017 THICK, PLATED WITH
 20 MICROINCHES MINIMUM HARD GOLD OVER 10 MICROINCHES
 MINIMUM SOFT GOLD OVER 30 TO 70 MICROINCHES SULFAMATE NICKEL.
 FLEX CIRCUIT: COPPER/POLYIMIDE LAMINATE, UL 94 V-0.
 FLEX BOLSTER: STEEL
 PCB BOLSTER: STEEL
 INSULATOR: POLYIMIDE TAPE
 SCREW: STEEL
 ASSEMBLY PIN: STEEL
- 2 PC BOARD PAD PLATING REQUIREMENTS:
 30 MICROINCHES MINIMUM HARD ELECTROPLATED GOLD
 OVER 100 MICROINCHES MINIMUM ELECTROPLATED NICKEL.
- 3. MAXIMUM BOARD THICKNESS: .100"
- 4. PC BOARD BOLSTERING REQUIREMENT:
 BOLSTER DIMENSIONS: SEE TOP BOLSTER.
 BOLSTER STIFFNESS: EQUAL OR BETTER THAN TOP BOLSTER.
 FLATNESS AT BOARD MATING FACE: .002" (.05 mm).
 M3 X 0.5 THREADS TWO PLACES, CLEARANCE FOR ASSEMBLY PINS.
 INSULATING MEMBER BETWEEN BOARD AND BOLSTER.
- 5. SCREW TORQUE REQUIREMENT: 6-8 IN*LB (0.7-0.9 N*m)
- 6 MINIMUM BEND RADIUS FOR FORMING FLEXIBLE CIRCUIT SHALL BE
 .250 (6.35) AND ALL BENDS SHALL BE LOCATED WITHIN AREA
 DEFINED ON SHEET 2.
- 7. EACH 7840 IS SHIPPED WITH 2 PCB BOLSTER PLATES.
- 8 SHIPPING:
 PCB BOLSTER PLATES FASTENED TO MATING FACE OF FLEX ASSEMBLY
 WITH M3 SCREWS.



THIS DOCUMENT CONTAINS PROPRIETARY INFORMATION OF AMPHENOL INTERCON SYSTEMS AND MAY NOT BE DISCLOSED, REPRODUCED OR OTHERWISE USED WITHOUT WRITTEN PERMISSION	
ALL DIMENSIONS AND TOLERANCES PER ASME Y14.5M-1994	THIRD ANGLE PROJECTION
INSPECTION	TOLERANCES UNLESS SPECIFIED OTHERWISE
◇ FIRST PIECE	2PLC ± .010
△ SPC	3PLC ± .005
○ IN-PROCESS	4PLC ± .002
	ANGLES ± 1°
MATERIAL <input type="checkbox"/>	FINISH <input type="checkbox"/>

AMPHENOL INTERCON SYSTEMS INC. ETTERS, PA 17319			
NAME			
cSTACK SYSTEM, FLEX ASSEMBLY & BOLSTER PLATE, 150 POSITION			
SIZE	PROD CODE	DRAWING NUMBER	REV
B	043	C - 7840	9
SCALE	CUSTOMER		SHEET 5 OF 5
1:1			

X-ON Electronics

Largest Supplier of Electrical and Electronic Components

Click to view similar products for [Ribbon Cables / IDC Cables](#) category:

Click to view products by [Amphenol](#) manufacturer:

Other Similar products are found below :

[FSK-12A](#) [AWG28-10G](#) [EHJ3C](#) [EHJ4C](#) [cab-LVDV-PWR-10-15](#) [FSP-25A](#) [cab-LVDV-DAT-34-15](#) [49635-C62-S2](#) [1-3636-600-5204](#) [92315-1408](#) [426171120-3](#) [2-1589735-3](#) [JSM015PP2DCC23N](#) [92301-0283](#) [ACL-eSSI-2](#) [92301-0718](#) [MMSDT-06-20-S-05.5-D-K-LDX](#) [IDD-04-G](#) [NM-2J2-051-PS1-JJAB](#) [1700/14SF \(100FT\)](#) [1700/26SF \(100FT\)](#) [1700/34SF \(100FT\)](#) [3801/09 \(100FT\)](#) [119-885](#) [318-818](#) [318-818-25](#) [318-818-50](#) [DS1057-06A282R-30.5](#) [DS1057-09A282R-30.5](#) [DS1057-12A282R-30.5](#) [DS1057-14A282R-76.5](#) [DS1057-20A282R-76.5](#) [DS1057-30A282R-76.5](#) [DS1057-34A282R-76.5](#) [DS1057-40A282R-76.5](#) [DS1057-60A282R-76.5](#) [DS1057-64A282R-76.5](#) [DS1058-08M28-30.5](#) [DS1058-30M28-30.5](#) [3750/10 \(100FT\)](#) [0015712](#) [0015905](#) [S30109](#) [11203](#) [11223](#) [11243](#) [11262](#) [0037147](#) [0022512](#) [0022412](#)