

# Amphenol Pcd Relay Sockets

## JRS/JRE Quick Mount Relay sockets

### Amphenol Pcd Quick Mount Relay Sockets

Amphenol Pcd recently introduced the JRS/JRE line Quick-Mount Relay Sockets. These relay sockets snap mount into standard aircraft panel cutouts and eliminate all socket-to-bulkhead mounting hardware, simplifying installation and dramatically reducing weight and installed cost. JRS/JRE line sockets meet the applicable performance and dimensional requirements of MIL-PRF-12883, are compatible with MIL SPEC approved relays from any manufacturer, and can be utilized in existing avionic systems with standard slotted panel cutouts.



JRS 4 Pole  
Relay Sockets

JRS 3 Pole  
Relay Sockets

JRS 2 Pole  
Relay Sockets

JRS 1 Pole  
Relay Sockets

JRE 2 Pole  
Relay Sockets

JRE 4 Pole  
Relay Sockets

### Key Features and Benefits

#### Socket Construction & Installation

JRS/JRE sockets maintain the same MIL mounting configurations and construction (molded polyetherimide bodies and silicone rubber sealing grommets) as Amphenol Pcd's traditional relay sockets. A heel and toe snap-in system allows the socket to be mounted to the panel without hardware and held securely in place. The assembled socket and relay meet all shock and vibration requirements

#### Lower Installed Cost

Elimination of loose hardware and the time required to assemble individual hardware components to the sockets results in a reduction of over 45% in socket installation time.

#### No Loose Hardware

The combination of snap-in relay-to-panel mounting and pre-assembled relay hardware eliminates all loose hardware from the socket and relay mounting and installation process. The logistical and safety issues related with loose hardware are completely avoided.

#### Relay Installation

JRE/JRS Relay Sockets feature externally threaded mounting screws and spacer assemblies which are pre-assembled to the relay. These mounting screws are captured and aligned by a conical spring, and utilized to fasten the relay to the socket. The screws engage internally threaded bushings captured in the socket and once the relay is secured, the socket snap features are no longer under stress.

#### Reduced Weight

The elimination of socket mounting hardware and a streamlined polyetherimide body combine to reduce the weight of a Quick-Mount Relay Socket. When compared to Amphenol Pcd standard MIL-PRF-12883 relay sockets provided with traditional mounting hardware, the weight is reduced by 30 to 40%.

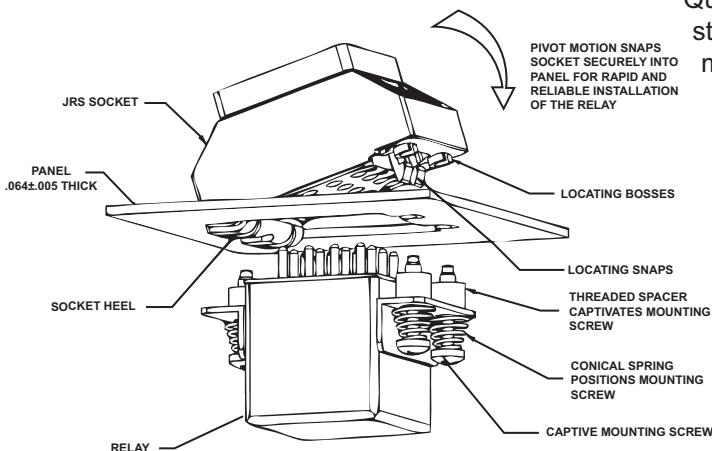

## Quick Mount Relay Sockets



Replaces MIL-PRF-12883/55  
Mates with M6106 Relays

# Quick Mount Relay Sockets

## JRS 1 Pole / 25 Amp / Size 12 & 16

### Operating Range

**Temperature:**

-65°C to 125°C

**Insulation Resistance:**

1000 Megaohms Min.

**Dielectric Withstanding Voltage:**

1500 VRMS at Sea Level

500 VRMS at 80,000 ft.

**Vibration:**

MIL-STD-202, Method 204

Test Condition G

**Shock:**

MIL-STD-213, Method 213

Test Condition C

### Materials

**Socket Body:**

Polythermide per ASTM-D5205

**Grommet:**

Silicone Rubber per A-A-59588

**Contact Retainers:**

Stainless Steel

**Internal Socket Contacts:**

Copper Alloy, Hard Gold Finish

per SAE-AMS-2422

### Socket Configurations

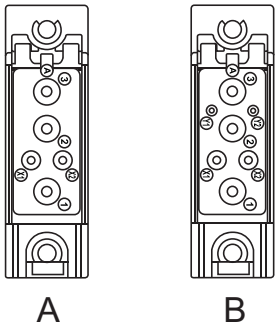

### Extended Height Relay Sockets

APCD P/N	QTY	Size	Contact	Mating Relay	Configuration
JRS500100	2	16/16	/92-533	M6106/19, M6106/20	A
	3	12/12	/92-535		
JRS500200	2	16/16	/92-533	M6106/19, M6106/20	B
	3	12/12	/92-535		

### Relay Socket Weight

Relay Socket	Pounds	Grams
Low Profile	.042	19

### Required Mounting Panel Cutout

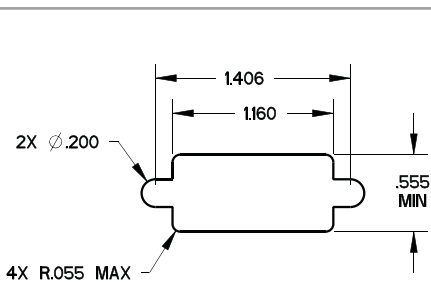

### Relay Socket Dimensions

#### Side View

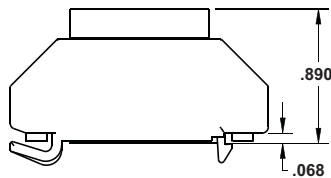

#### Top View

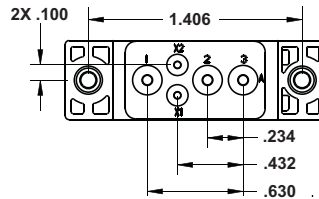

#### Bottom View

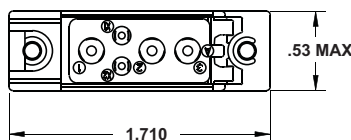

### Mounting Hardware

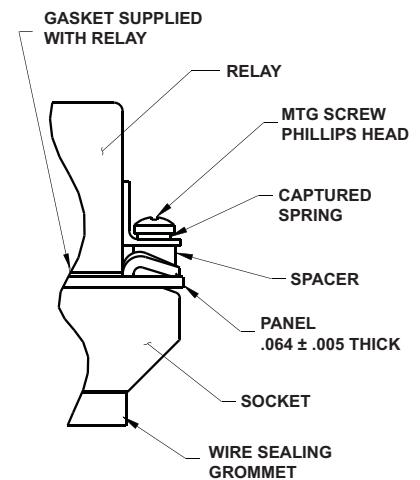

### Part Number Instructions

APCD P/N	Hardware	Contacts
JRS500100	NONE	NONE
JRS500101	NONE	YES
JRS500110	YES	NONE
JRS500111	YES	YES

# Quick Mount Relay Sockets

## JRS 2 Pole / 10 Amp / Size 16

### Operating Range

**Temperature:**

-65°C to 125°C

**Insulation Resistance:**

1000 Megaohms Min.

**Dielectric Withstanding Voltage:**

1500 VRMS at Sea Level

500 VRMS at 80,000 ft.

**Vibration:**

MIL-STD-202, Method 204

Test Condition G

**Shock:**

MIL-STD-213, Method 213

Test Condition C

### Materials

**Socket Body:**

Polythermide per ASTM-D5205

**Grommet:**

Silicone Rubber per A-A-59588

**Contact Retainers:**

Stainless Steel

**Internal Socket Contacts:**

Copper Alloy, Hard Gold Finish per SAE-AMS-2422

## Quick Mount Relay Sockets



Replaces MIL-PRF-12883/41  
Mates with M83536 Relays

### Extended Height Relay Sockets

APCD P/N	QTY	Size <sup>1</sup>	Contact	Mating Relay	Configuration
JRS200100	8	16/16	/92-533	M83536	A
JRS200200	8	16/16	/92-533	M83536	B
JRS200300	8	16/16	/92-533	M83536	C

### Socket Configurations

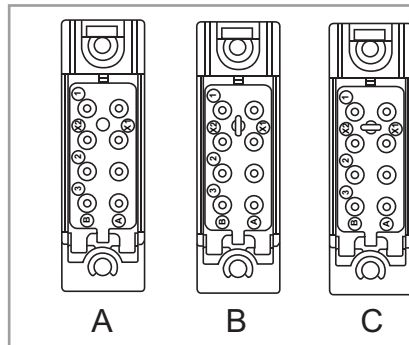

### Relay Socket Weight

Relay Socket	Pounds	Grams
Low Profile	.042	19

### Required Mounting Panel Cutout

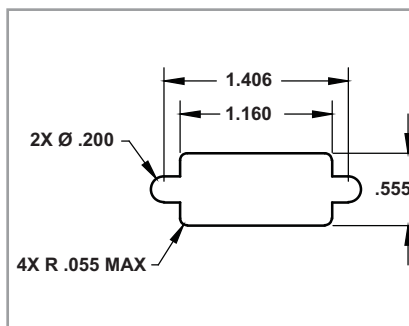

### Relay Socket Dimensions

#### Side View

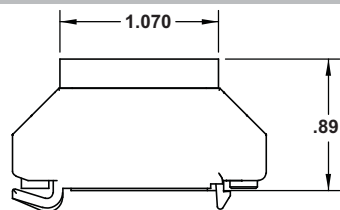

#### Top View

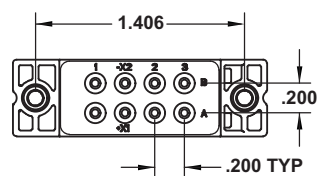

#### Bottom View

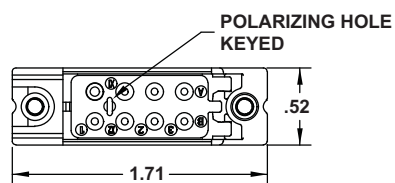

### Mounting Hardware

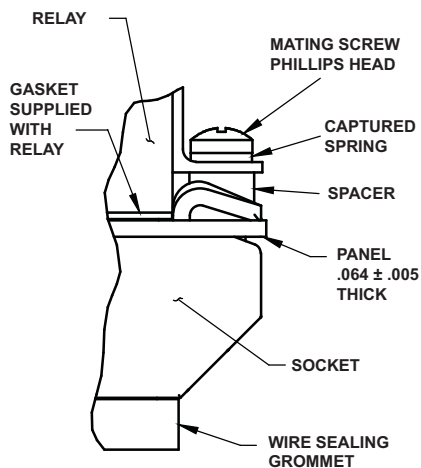

### Part Number Instructions

APCD P/N	Hardware	Contacts
JRS200100	NONE	NONE
JRS200101	NONE	YES
JRS200110	YES	NONE
JRS200111	YES	YES

Amphenol Pcd

## Quick Mount Relay Sockets



Replaces MIL-PRF-12883/48  
Mates with M6106 & MS27743 Relays

# Quick Mount Relay Sockets

## JRS 3 Pole / 25 Amp / Size 12 & 16

### Operating Range

Temperature:

-65°C to 125°C

Insulation Resistance:

1000 Megaohms Min.

Dielectric Withstanding Voltage:

1500 VRMS at Sea Level

500 VRMS at 80,000 ft.

Vibration:

MIL-STD-202, Method 204

Test Condition G

Shock:

MIL-STD-213, Method 213

Test Condition C

### Materials

Socket Body:

Polythermide per ASTM-D5205

Grommet:

Silicone Rubber per A-A-59588

Contact Retainers:

Stainless Steel

Internal Socket Contacts:

Copper Alloy, Hard Gold Finish

per SAE-AMS-2422

### Socket Configurations

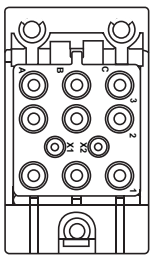

A

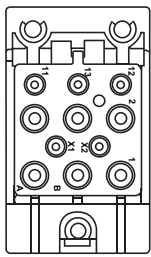

B

### Extended Height Relay Sockets

APCD P/N	QTY	Size <sup>1</sup>	Contact	Mating Relay	Configuration
JRS300100	2	16/16	/92-533	M6106/13, MS27743	A
	9	12/12	/92-535		
JRS310100	5	16/16	/92-533	M6106/13, MS27743	B
	6	12/12	/92-535		

### Relay Socket Weight

Relay Socket	Pounds	Grams
Low Profile	.075	34

### Required Mounting Panel Cutout

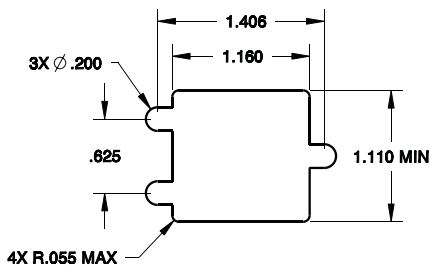

### Relay Socket Dimensions

#### Side View

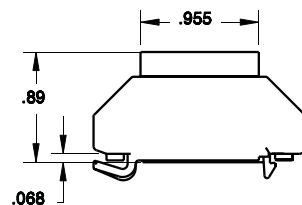

#### Top View

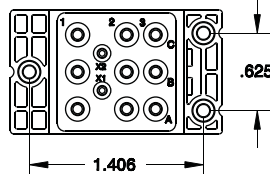

#### Bottom View

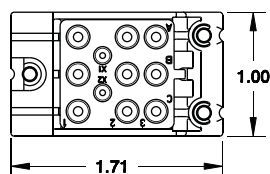

### Mounting Hardware

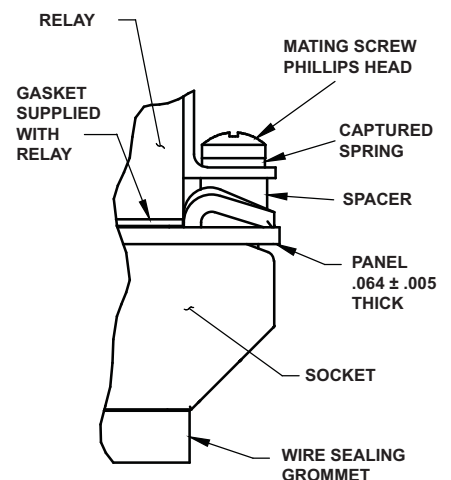

### Part Number Instructions

APCD P/N	Hardware	Contacts
JRS300100	NONE	NONE
JRS300101	NONE	YES
JRS300110	YES	NONE
JRS300111	YES	YES

# Quick Mount Relay Sockets

## JRS 4 Pole / 10 Amp / Size 16

### Operating Range

**Temperature:**

-65°C to 125°C

**Insulation Resistance:**

1000 Megaohms Min.

**Dielectric Withstanding Voltage:**

1500 VRMS at Sea Level

500 VRMS at 80,000 ft.

**Vibration:**

MIL-STD-202, Method 204

Test Condition G

**Shock:**

MIL-STD-213, Method 213

Test Condition C

### Materials

**Socket Body:**

Polythermide per ASTM-D5205

**Grommet:**

Silicone Rubber per A-A-59588

**Contact Retainers:**

Stainless Steel

**Internal Socket Contacts:**

Copper Alloy, Hard Gold Finish  
per SAE-AMS-2422

## Quick Mount Relay Sockets



Replaces MIL-PRF-12883/40  
Mates with M83536, 83726 & MS27709 Relays

### Extended Height Relay Sockets

APCD P/N	QTY	Size <sup>1</sup>	Contact	Mating Relay	Configuration
JRS400100	14	16/16	/92-533	M83536, M83726, MS27709	A
JRS400200	14	16/16	/92-533	M83536, M83726, MS27709	B
JRS400300	14	16/16	/92-533	M83536, M83726, MS27709	C
JRS400400	14	16/16	/92-533	M83536, M83726, MS27709	D
JRS400500	16	16/16	/92-533	M83536, M83726, MS27709	E

### Socket Configurations

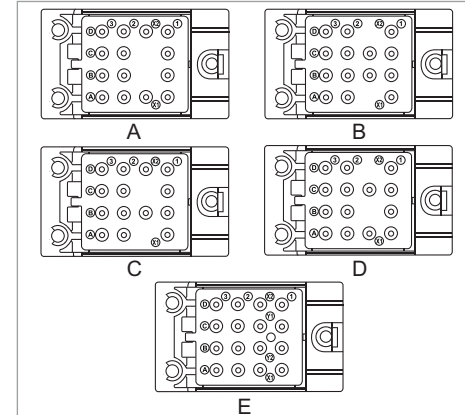

### Relay Socket Dimensions

#### Side View

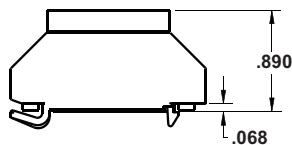

#### Top View

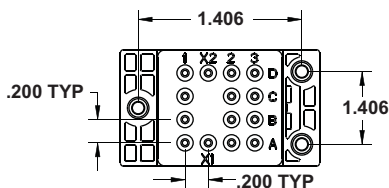

#### Bottom View

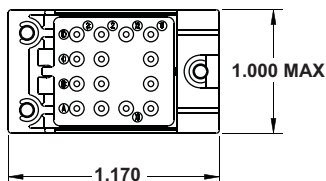

### Mounting Hardware

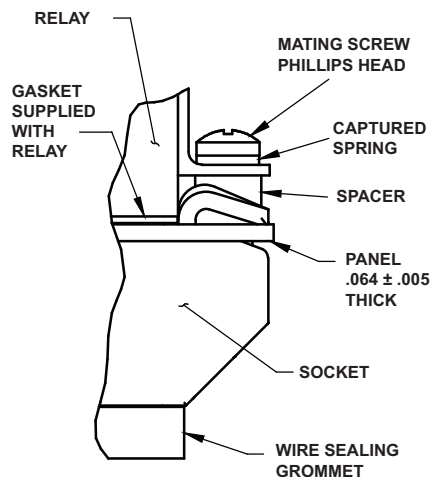

### Part Number Instructions

APCD P/N	Hardware	Contacts
JRS400100	NONE	NONE
JRS400101	NONE	YES
JRS400110	YES	NONE
JRS400111	YES	YES

### Relay Socket Weight

Relay Socket	Pounds	Grams
Low Profile	.068	31

### Required Mounting Panel Cutout

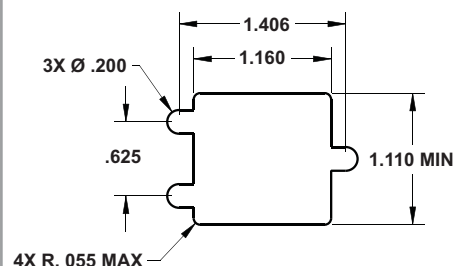

Amphenol Pcd

# Quick Mount Relay Sockets

## JRE 2 Pole / 5 Amp / Size 20

### Quick Mount Relay Sockets



Replaces MIL-PRF-12883/41  
Mates with M83536 & M6106 Relays

#### Operating Range

**Temperature:**

-65°C to 125°C

**Insulation Resistance:**

1000 Megaohms Min.

**Dielectric Withstanding Voltage:**

1000 VRMS at Sea Level

500 VRMS at 80,000 ft.

**Vibration:**

MIL-STD-202, Method 204

Test Condition G

**Shock:**

MIL-STD-213, Method 213

Test Condition C

#### Materials

**Socket Body:**

Polythermide per ASTM-D5205

**Grommet:**

Silicone Rubber per A-A-59588

**Contact Retainers:**

Stainless Steel

**Internal Socket Contacts:**

Copper Alloy, Hard Gold Finish

per SAE-AMS-2422

### Socket Configurations

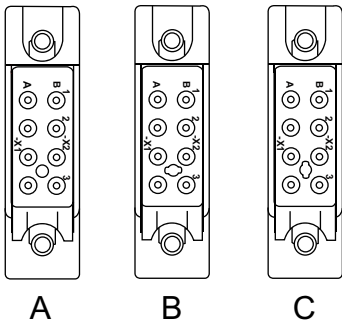

### Extended Height Relay Sockets

APCD P/N	QTY	Size	Contact	Mating Relay	Configuration
JRE200100	8	20/20	/101-533	M83536, M6106	A
JRE200200	8	20/20	/101-533	M83536, M6106	B
JRE200300	8	20/20	/101-533	M83536, M6106	C

*Applies to all plug-in type relays of these documents*

### Relay Socket Weight

Relay Socket	Pounds	Grams
Low Profile	.042	19

### Recommended Mounting Panel Cutout

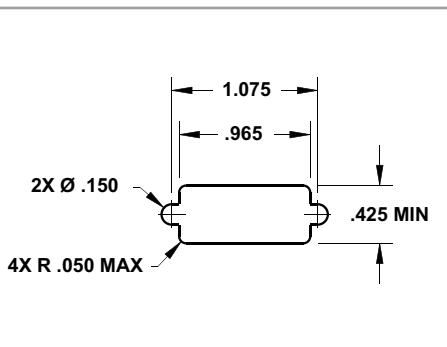

### Relay Socket Dimensions

#### Side View

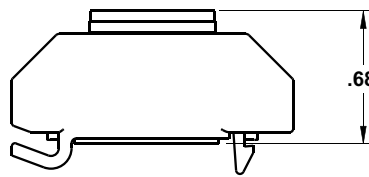

#### Top View

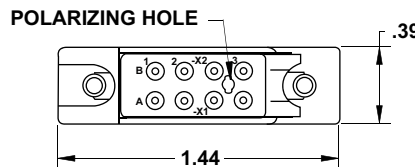

#### Bottom View

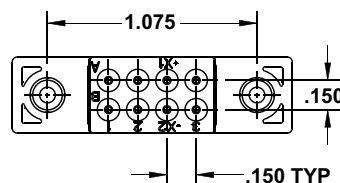

### Mounting Hardware

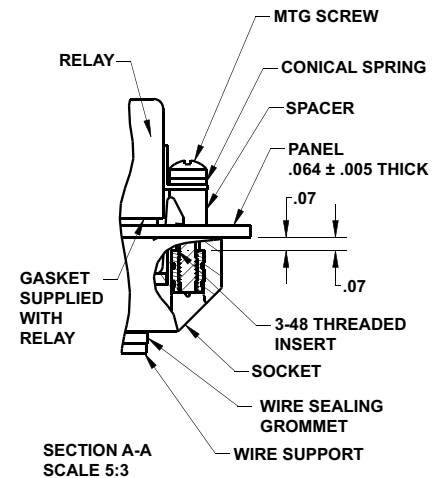

### Part Number Instructions

APCD P/N	Hardware	Contacts
JRE200100	NONE	NONE
JRE200101	NONE	YES
JRE200110	YES	NONE
JRE200111	YES	YES

# Quick Mount Relay Sockets

## JRE 4 Pole / 5 Amp / Size 20

### Operating Range

**Temperature:**

-65°C to 125°C

**Insulation Resistance:**

1000 Megaohms Min.

**Dielectric Withstanding Voltage:**

1000 VRMS at Sea Level

500 VRMS at 80,000 ft.

**Vibration:**

MIL-STD-202, Method 204

Test Condition G

**Shock:**

MIL-STD-213, Method 213

Test Condition C

### Materials

**Socket Body:**

Polythermide per ASTM-D5205

**Grommet:**

Silicone Rubber per A-A-59588

**Contact Retainers:**

Stainless Steel

**Internal Socket Contacts:**

Copper Alloy, Hard Gold Finish

per SAE-AMS-2422

## Quick Mount Relay Sockets



Replaces MIL-PRF-12883/44  
Mates with M83536 Relays

### Extended Height Relay Sockets

APCD P/N	QTY	Size	Contact	Mating Relay	Configuration
JRE400100	10	20/20	/101-533	M83536/5, M83536/6, M83536/7	A
JRE400200	12	20/20	/101-533	M83536/5, M83536/6, M83536/7	B
JRE400300	12	20/20	/101-533	M83536/5, M83536/6, M83536/7	C
JRE400400	12	20/20	/101-533	M83536/5, M83536/6, M83536/7	D

### Socket Configurations

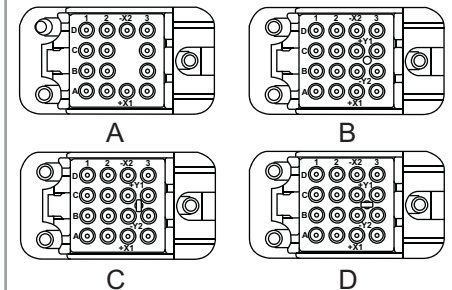

### Relay Socket Dimensions

#### Side View

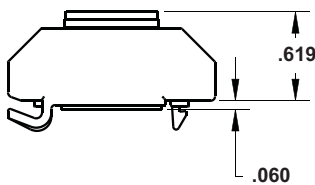

#### Top View

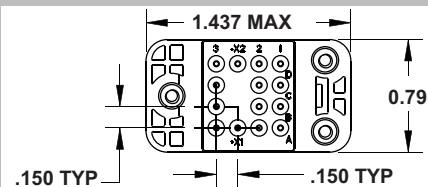

#### Bottom View

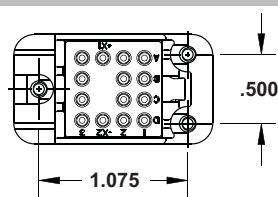

### Mounting Hardware

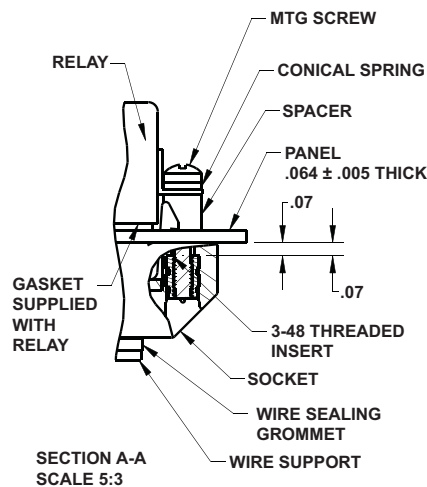

### Part Number Instructions

APCD P/N	Hardware	Contacts
JRE400100	NONE	NONE
JRE400101	NONE	YES
JRE400110	YES	NONE
JRE400111	YES	YES

### Relay Socket Weight

Relay Socket	Pounds	Grams
Low Profile	.068	31

### Required Mounting Panel Cutout

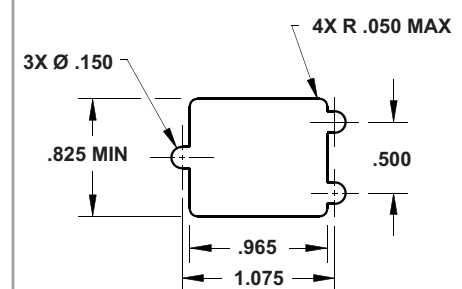

**Amphenol Pcd**

## X-ON Electronics

Largest Supplier of Electrical and Electronic Components

*Click to view similar products for [Relay Sockets & Fixings](#) category:*

*Click to view products by [Amphenol](#) manufacturer:*

Other Similar products are found below :

[00008258500](#) [00111976502](#) [0000-825-81-00](#) [60SY4S05](#) [M41G](#) [670-0125](#) [670-0127](#) [6700152](#) [670-0153](#) [6700156](#) [D258-2TS00](#) [70-309](#) [7-1393143-3](#) [7-1616360-5](#) [8000-DG2-5](#) [911361](#) [9-1616339-5](#) [PJF11N](#) [GDA12HA](#) [GDA12HD](#) [GDA12SA](#) [GDA12SD](#) [GDA16HD](#) [GDA22HA](#) [GDA95A](#) [GDA95D](#) [GFX20](#) [PT08QN](#) [PT 1/8 D = 3.2](#) [GUA1](#) [GUA2-11](#) [GUA4-04](#) [GUA4-31](#) [GUM5R](#) [GUR-277](#) [GURX-277](#) [GUW12](#) [GUW95](#) [GUZ63L](#) [R99-11 FOR MY\(NAMEPLATE\)](#) [D52PR2T](#) [RES100K](#) [1310H-HDC](#) [1390H-1ST](#) [1393824-3](#) [1390H-2PC](#) [1410-2SM](#) [1410-3SM](#) [1419106-5](#) [RMOB 1-24 JR](#)