

# SSI Technologies – Application Note PS-AN5

## MediaGauge™ (Model MGA-9V) Digital Pressure Gage

### Product Overview

#### Product Description

The MediaGauge™ Model MGA-9V is a NEMA 4X rated stand alone 9V battery operated multi-functional digital pressure gage. The MGA-9V digital pressure gage consists of a piezoresistive pressure sensing element, signal conditioning circuitry for temperature and calibration compensation, a 304L stainless steel pressure port and a LCD back lit display. The MGA-9V is a lower cost digital pressure gage in the MediaGauge™ family with accuracy of **± 1.0 % full scale for dry air and non-corrosive gas applications only.**

The MediaGauge™ MGA-9V comes standard with a variety of keypad operated functions – multiple pressure unit display reading (PSI, BAR or MPA); memory storage of maximum peak pressure reading; and zero adjustment.

The MGA-9V digital pressure gage has better accuracy, longer life and *standard* multiple functions which make it a better choice than mechanical pressure gages. These compact 2 ½ inch, robust gages measure pressures from **30 PSI to 300 PSI.**

#### Product Features

- f **Accuracy:** ± 1.0 % Full Scale
- f **Pressure Ranges:** 30, 100, 300 PSI
- f **Keypad Operated Functions:** Auto zero and peak hold
- f **Operating Temperature:** -10°C to 60°C
- f **Storage Temperature:** -20°C to 85°C



MediaGauge™ Model MGA-9V with rubber boot option

- f **Typical Applications:** Process Control; Compressors
- f **NIST traceable certificates available**
- f **NEMA 4X Rating**
- f **Chemical Compatibilities:** Non-corrosive gases and dry air
- f **LCD Display Battery Saver Mode:** MGA-9V automatically powers down after 3 minutes.
- f **Multiple Pressure Units:** PSI, BAR, MPA (kg/cm<sup>2</sup>)
- f **Compact, Robust Package:** 2 ½ inches with black ABS Thermoplastic case

# SSI Technologies – Application Note PS-AN5

## MediaGauge™ (Model MGA-9V) Digital Pressure Gage

### Product Overview

#### Measurement Technology

In general, pressure measurement technology translates a force from an induced pressure into an electrical quantity. In digital pressure gages, the electrical quantity is then translated into pressure units and digitally displayed.

The SSI's MediaGauge™ MGA-9V digital pressure gage includes an 304L stainless steel input pressure port, a piezoresistive pressure sensing element, signal conditioning circuitry for temperature and calibration compensation, and a LCD that displays the pressure measured in either PSI, BAR or MPA (kg/cm<sup>2</sup>) units.

The piezoresistive sensing element contains a silicon crystal semiconductor. Strain gages (resistive elements) in the silicon are used in a Wheatstone Bridge circuit. When pressure is applied, the resistivity of the strain gages changes proportional to the pressure applied. One leg of the bridge measures the input pressures port. The other leg of the bridge is connected to the reference port (vacuum pressure 0 PSI) the input pressure port is compared to.

Since piezoresistive pressure sensors are sensitive to changes in temperature, the MediaGauge™ uses signal conditioning to compensate for temperature and calibration. The output signal is then converted into one of 3 user selectable forms (select units with the ON/UNIT/OFF button):

- 1) PSI
- 2) BAR
- 3) MPA (kg/cm<sup>2</sup>)

The MediaGauge™ MGA-9V will display the pressure reading after the ON/UNIT/OFF button is depressed. The pressure measurement reading is updated 3 times per second.

#### MediaGauge™ MGA-9V Panel

The MediaGauge™ MGA-9V panel has a LCD display and three multi-functional buttons – ON/UNIT/OFF; LIGHT/P-H (Peak-Held) and RESET/CLEAR.

The **ON/UNIT/OFF button** is used to display the pressure reading; switch between pressure units (PSI; BAR; and MPA) and to power down the unit.

**To power on the unit:** Press the ON/UNIT/OFF button. The MediaGauge™ MGA-9V has a battery saver mode and will automatically shut itself off after 5 minutes.

**To display the pressure reading in a different pressure unit:** Continue to press the ON/UNIT/OFF button until the arrow in the LCD points to the pressure units desired.

**To manually power down the unit:** Press the ON/UNIT/OFF button and hold down for 3 seconds until OFF is displayed and then release the button.

The **LIGHT/P-H (Peak-Held) button** is used to turn the LCD LIGHT on/off and to display the maximum peak pressure the unit has measured.

**To turn the LCD LIGHT on:** Press the LIGHT/P-H button once.

**To turn the LCD LIGHT off:** Press the LIGHT/P-H button again.



# SSI Technologies – Application Note PS-AN5

## MediaGauge™ (Model MGA-9V) Digital Pressure Gage

### Product Overview

**To see the maximum peak pressure the unit has measured:**

Press and hold down the LIGHT/P-H button for 3 seconds. The maximum pressure reading will be blinking. If the maximum pressure read was over the unit's maximum pressure range, o.L will be blinking on the display.

**To return to the current pressure reading:** Press the LIGHT/P-H button and hold down for 3 seconds.

The **RESET/CLEAR button** is used to reset the gage to whatever pressure is currently being applied to the port and to clear the stored maximum peak pressure reading.

**To reference your MediaGauge™ digital pressure gage to the input port:** Press and hold the RESET/CLEAR button for 3 seconds. The MediaGauge™ MGA-9V will now be reference to your input port. For example, if you have 20 psi on the display and then you press and hold the RESET/CLEAR button for 3 seconds the display will show 0.0 psi. A measurement of 30 psi would then read as 10 psi on the display.

**To reset the MediaGauge™ digital pressure gage:** Make sure the input port is either disconnected or connected to a 0 psi input. Press and hold down the RESET/CLEAR button for 3 seconds.

**To clear the maximum peak pressure reading:** Press and hold down the LIGHT/P-H button for 3 seconds until the maximum pressure reading appears on the LCD (it will be blinking). Release the LIGHT/P-H button. Press and hold down RESET/CLEAR button for 3 seconds.

### Installation/Mounting

- 1) Mount the MediaGauge™ MGA-9V digital pressure gage on a suitable (1/4" NPT) female fitting. Use Teflon tape or pipe dope to seal the threads.
- 2) Do no over tighten. Torque to 150 in lbs +/- 1 in lb.

### Electrical Specifications

Supply Voltage	9V Battery
Response Time	< 1 ms
Accuracy	±1.0 FS
LCD Resolution (30 PSI)	0.01
LCD Resolution (100; 300 PSI)	0.1
Proof Pressure	3 X Full Scale
Burst Pressure	10 X Full Scale or 15,000 psi whichever is less
Operating Temperature Range	-10° to 60°C (14° to 140°F)
Storage Temperature Range	-20° to 85°C (-4° to 185°F)



# SSI Technologies – Application Note PS-AN5

## MediaGauge™ (Model MGA-9V) Digital Pressure Gage

### Product Overview

#### Tested Conditions

<b>Humidity</b>	250 Hours (40°C and 90% to 95% R.H.)
<b>Pressure/Temperature Cycles</b>	> 1.8 million Cycles (0 to FS @ 8Hz and -20° to 85°C)
<b>Thermal Shock</b>	250 Cycles (85 to -20°C. 0.5 hr soaks at temperature)
<b>Vibration</b>	144 Hours (100 to 2000 Hz, 20g sinusoidal in 3 axes)

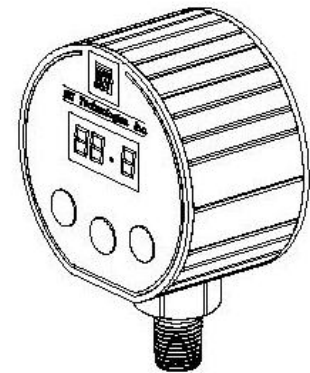
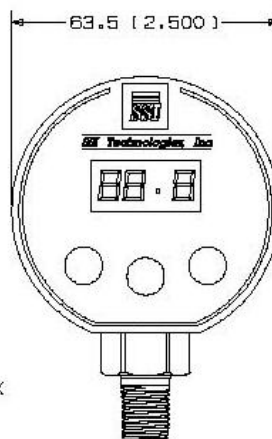
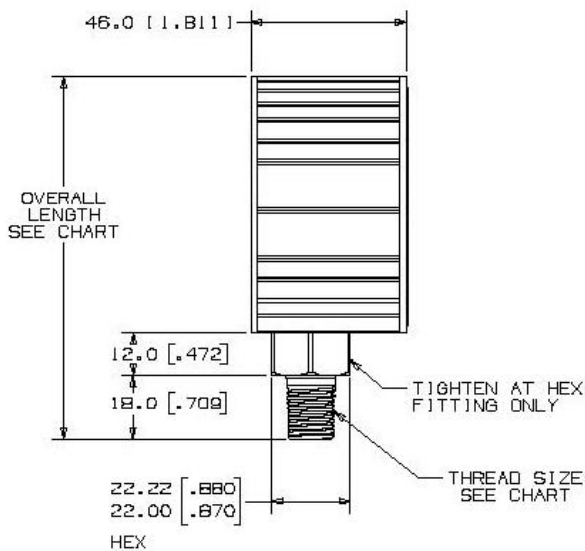

LCD HEIGHT 15.1 [.594]

#### MediaGauge™ MGA-9V with 22mm Hex and 1/4" - 18 NPT Process Connection

SSI TECHNOLOGIES, INC.  
 Controls Division  
 1309 Plainfield Ave.  
 Janesville, WI 53545-0450  
 Phone: (608)758-1500  
 Fax: (608)758-2491  
 www.ssitechnologies.com



**SSI Technologies, Inc.**  
 — CONTROLS DIVISION —

Copyright August 30, 2012  
 SSI Technologies Inc.  
 All Rights Reserved  
 Revision 3

# SSI Technologies – Application Note PS-AN5

## MediaGauge™ (Model MGA-9V) Digital Pressure Gage

### Product Overview

#### Digital Pressure Gage Ordering System

The following explains SSI's MediaGauge™ Digital Pressure gage order number sequence.

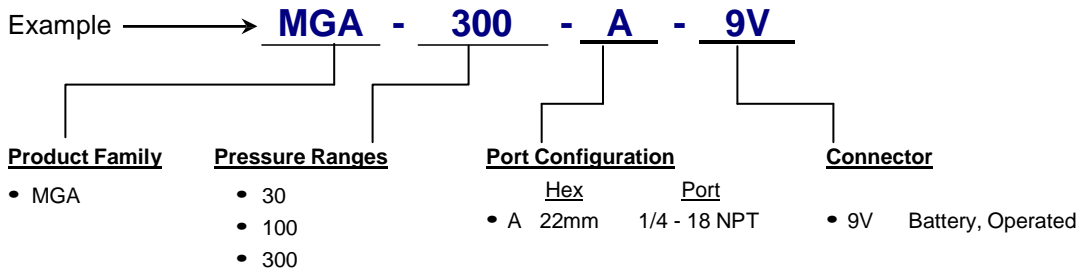

#### Rubber Boot Options:

Order P/N 24610.1 for Model MGA



## X-ON Electronics

Largest Supplier of Electrical and Electronic Components

*Click to view similar products for [Industrial Pressure Sensors](#) category:*

*Click to view products by [Amphenol](#) manufacturer:*

Other Similar products are found below :

[75380-05](#) [76053-00000300-01](#) [76053-00000300-05](#) [76061-00000015-01](#) [76062-B00000350-01](#) [76063-00000350-05](#) [76083-05000500-01](#)  
[76311-05](#) [76577-00000070-01](#) [76584-M00000100-24](#) [77343-24.0H2-01](#) [77343-25.0H2-01](#) [78291-B00000060-01](#) [78303-B00000400-01](#)  
[78303-B00000400-05](#) [78316-B00000030-01](#) [78353-B00000020-05](#) [78665-00000014-05](#) [78677-B00000070-05](#) [78678-00000040-01](#) [79279-](#)  
[00000060-01](#) [79296-B00000350-01](#) [79322-00250035-01](#) [79614-30.0H2-14](#) [79670-00000090-15](#) [79700-00002750-01](#) [79917-B00000280-01](#)  
[80569-00700100-01](#) [81509081](#) [81739-B00000900-01](#) [81807-B00000020-01](#) [MLH010BST01A](#) [MLH010BST14A](#) [MLH025BGC13B](#)  
[MLH025BSCDJ1292](#) [MLH025BSCDJ1303](#) [MLH750PSCDJ1245](#) [82903-B00000020-01](#) [83250-02500600-05](#) [83271-00000040-04](#) [83278-](#)  
[B00000200-21](#) [83286-00000150-01](#) [83299-00000150-05](#) [83303-00000600-01](#) [83305-00001350-01](#) [83330-00000100-01](#) [83349-00001470-24](#)  
[83350-04.0HG-05](#) [83350-15.0H2-05](#) [83357-00000030-21](#)