

REVISIONS			
REV	DESCRIPTION, ECN, EAR NO.	DATE	APP'D
D	PRODUCT DRAWING (EAR 14357)	MAR30/16	K.L.
E	PRODUCT DRAWING (EAR 14357)	JUN6/16	K.L.

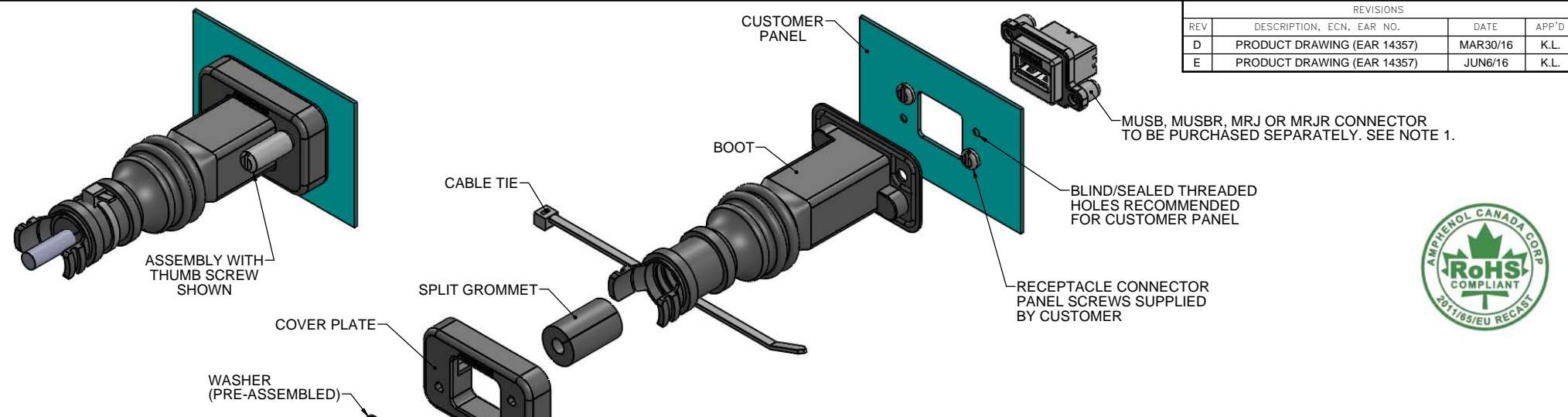

NOTES

1. THIS HOOD IS SUITABLE FOR USE WITH AMPHENOL RUGGED MODULAR JACKS & USB SERIES A RECEPTACLES - AMPHENOL SERIES MRJ, MRJR, MUSB-A & MUSBR-A (STANDARD PROFILE).
2. KIT CONTAINS ONE BOOT, ONE COVER PLATE, UP TO TWO SPLIT GROMMETS, ONE CABLE TIE, TWO SCREWS & TWO WASHERS. SCREWS & WASHERS ARE SUPPLIED PRE-ASSEMBLED TO THE COVER PLATE TO MINIMIZE LOSS OF PARTS DURING USE.
3. THE HOOD CAN BE FIELD OR FACTORY ASSEMBLED OVER EXISTING STANDARD USB OR RJ PLUGS THAT ARE ALREADY TERMINATED TO A CABLE. SEE DRAWING SHEET 3 FOR A SUGGESTED ASSEMBLY PROCEDURE. FOR IMPROVED SEALING PERFORMANCE, THE USE OF A CABLE TIE GUN TO TIGHTEN THE CABLE TIE IS RECOMMENDED (EXAMPLE: PALADIN TOOLS CABLE TIE GUN P/N 1828.1 WITH SETTING 1). THE ASSEMBLY PROCEDURE CAN BE ALTERED TO SUIT CUSTOMER PREFERENCES OR REQUIREMENTS.
4. CUSTOMER PANEL REQUIRES TWO ADDITIONAL MOUNTING HOLES. THESE HOLES ARE RECOMMENDED TO BE BLIND/SEALED HOLES SO THAT ENCLOSURE REMAINS SEALED. IN UNMATED CONDITION, RECEPTACLE MAINTAINS ENCLOSURE SEAL. IN MATED CONDITION, BOOT ASSEMBLY ENSURES SEAL OF MATING INTERFACE AREA.
5. BOOT ACCORDION SECTION ALLOWS FLEXIBILITY FOR CABLE TIE LOCATION ALONG CABLE LENGTHWISE. THIS MAY BE NECESSARY TO SUIT EXTRA LONG PLUG OVER-MOULDS OR TO AVOID FERRITES MOULDED INTO THE CABLE. IF A MATING RECEPTACLE & PANEL ARE NOT AVAILABLE DURING BOOT ASSEMBLY, THE ACCORDION SECTION ALSO ALLOWS FLEXIBILITY FOR THE BOOT FLANGE LOCATION.
6. FLEXIBILITY OF BOOT PERMITS PLUG/RECEPTACLE INTERFACE TO BE UNMATED & RE-MATED WITHOUT DIS-ASSEMBLY OR REMOVAL OF THE PLUG HOOD. THIS FEATURE SIMPLIFIES EQUIPMENT TEST & DIAGNOSTICS IN FIELD SERVICE APPLICATIONS.
7. MATERIAL: ALL MATERIALS ARE RoHS COMPLIANT PER EU DIRECTIVE 2011/65/EU & AMENDMENTS
 - BOOT: FLEXIBLE RUBBER, BLACK & TRANSLUCENT OPTIONS
 - COVER PLATE: THERMOPLASTIC POLYESTER OR NYLON, GLASS REINFORCED, BLACK
 - HARDWARE: STAINLESS STEEL
 - CABLE TIE: NYLON, BLACK
 - GROMMET: SILICONE RUBBER, BLACK
8. GROMMET CODE 21 (4.50 [.177] I.D.) IS SUITABLE FOR CABLES UP TO 4.50 [.177] OUTSIDE JACKET DIAMETER. GROMMET CODE 31 (6.40 [.252] I.D.) IS SUITABLE FOR CABLES BETWEEN 4.50 [.177] & 6.50 [.256] OUTSIDE JACKET DIAMETER. LARGER DIAMETER CABLES DO NOT REQUIRE A GROMMET.
9. TO ORDER CABLE TIES SEPARATELY, SPECIFY P/N MUSBR-2AHD-501BP.
10. OPERATING TEMPERATURE -55°C TO +105°C.

ORDERING CODE:

MUSBR - AHD2 - X X1 XX

SERIES, RUGGED USB _____

HOOD, BOOT STYLE _____

SCREW, THREAD & BOOT OPTIONS _____

2 = SCREW - #4-40 UNC THREAD, BLACK BOOT

3 = THUMB SCREW - #4-40 UNC THREAD, BLACK BOOT

7 = SCREW - #4-40 UNC THREAD, TRANSLUCENT BOOT

8 = THUMB SCREW - #4-40 UNC THREAD, TRANSLUCENT BOOT

L = SCREW - M3 x 0.5 THREAD, BLACK BOOT

M = THUMB SCREW - M3 x 0.5 THREAD, BLACK BOOT

S = SCREW - M3 x 0.5 THREAD, TRANSLUCENT BOOT

T = THUMB SCREW - M3 x 0.5 THREAD, TRANSLUCENT BOOT

GROMMET OPTION _____

01 = NO GROMMET

21 = 4.50 [.177] INSIDE DIAMETER GROMMET

31 = 6.40 [.252] INSIDE DIAMETER GROMMET

41 = WITH BOTH 4.50 [.177] & 6.40 [.252] GROMMETS

PACKAGING OPTIONS _____

BP = BULK PACKED, COMPONENTS BAGGED SEPARATELY IN CARTON

SK = SINGLE KIT, COMPONENTS FOR EACH HOOD IN SINGLE BAG

STANDARD PART NUMBER - MUSBR-AHD2-241SK FOR STOCK IN DISTRIBUTION
CONSULT WITH AMPHENOL CANADA FOR OTHER OPTIONS OR SPECIAL REQUESTS.

UNLESS SPECIFIED OTHERWISE	DRAWN	B.COPPING	DEC5/14
PRIMARY UNITS MILLIMETERS	CHECKED	K.LAMBIE	DEC5/14
SECONDARY INCHES	M.E. APP'D		
REFERENCE IN PARENTHESES	Q.A. APP'D		
GENERAL TOLERANCES	DWG APPR.		
1 DECIMAL PLACE	ENG. REL. NO.	EAR 14327	
2 DECIMAL PLACES	REF.		
3 DECIMAL PLACES	THIRD ANGLE PROJECTION		
ANGULAR DEGREES	DO NOT SCALE DRAWING		

Amphenol Canada Corp.
www.amphenolcanada.com

MUSBR HOOD FOR USB OR RJ PLUG, BOOT STYLE DESIGN, FOR SEALING MATING INTERFACE, RoHS COMPLIANT

DWG. NO. **P-MUSBR-AHD2-XX1XX** REV **E**

CODE ID NO. 03554 DWG SIZE: X SCALE: 2:1 SHEET 1 OF 3

REVISIONS			
REV	DESCRIPTION, ECN, EAR NO.	DATE	APP'D
D	PRODUCT DRAWING (EAR 14357)	MAR30/16	K.L.
E	PRODUCT DRAWING (EAR 14357)	JUN6/16	K.L.

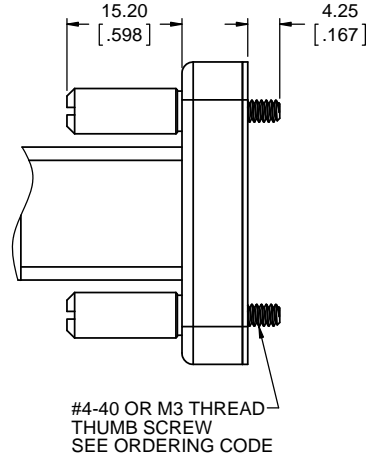
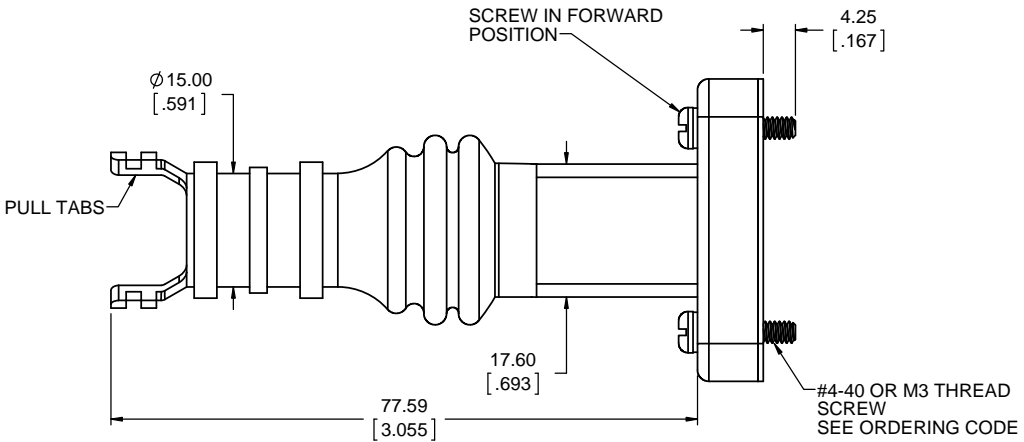
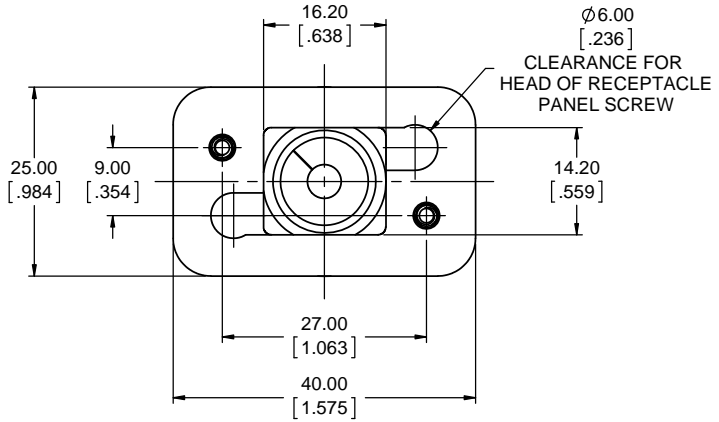
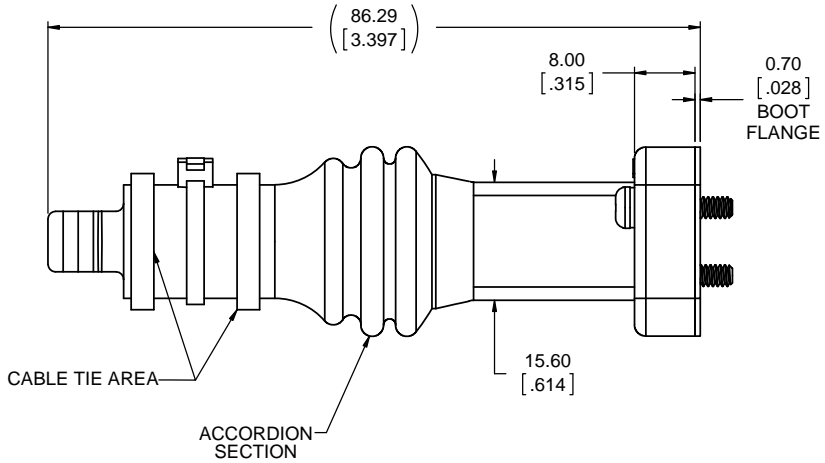
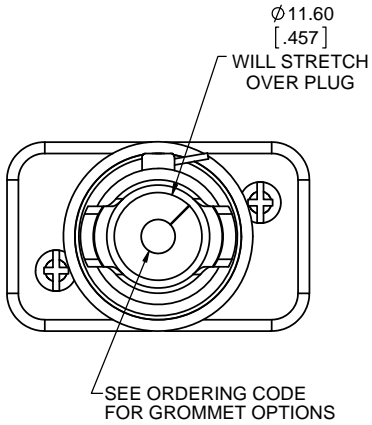

VIEW WITH THUMB SCREWS SHOWN

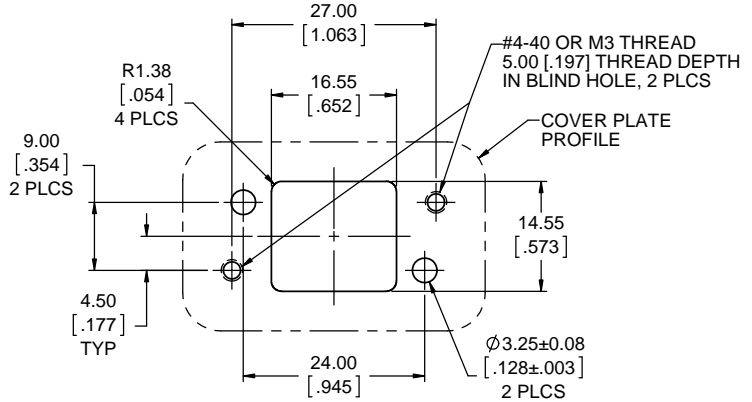

RECOMMENDED PANEL CUTOUT OUTSIDE PANEL VIEW



UNLESS SPECIFIED OTHERWISE	DRAWN	B.COPPING	DEC5/14
PRIMARY UNITS MILLIMETERS	CHECKED	K.LAMBIE	DEC5/14
SECONDARY UNITS INCHES	M.E. APP'D		
REFERENCE IN PARENTHESES	Q.A. APP'D		
GENERAL TOLERANCES	DWG APPR.		
1 DECIMAL PLACE	ENG. REL. NO.	EAR 14327	
2 DECIMAL PLACES	REF.		
3 DECIMAL PLACES	THIRD ANGLE PROJECTION		
ANGULAR DEGREES	DO NOT SCALE DRAWING		

Amphenol Canada Corp.
www.amphenolcanada.com

MUSBR HOOD FOR USB OR RJ PLUG, BOOT STYLE DESIGN, FOR SEALING MATING INTERFACE, RoHS COMPLIANT

DWG. NO. **P-MUSBR-AHD2-XX1XX** REV **E**

CODE ID NO. 03554 DWG SIZE: X SCALE: 2:1 SHEET 2 OF 3

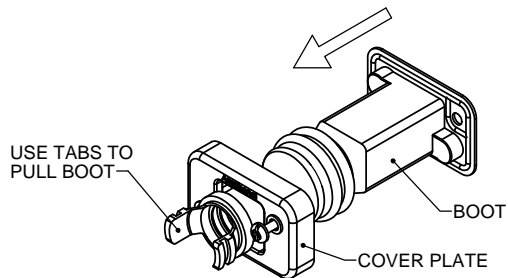

STEP 1
PULL BOOT THROUGH
COVER PLATE.

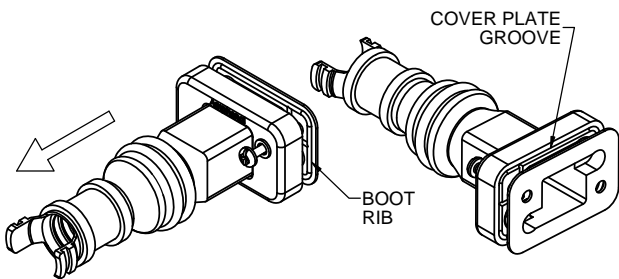

STEP 2
CONTINUE TO PULL BOOT
UNTIL BOOT FLANGE ALMOST
TOUCHES COVER PLATE.

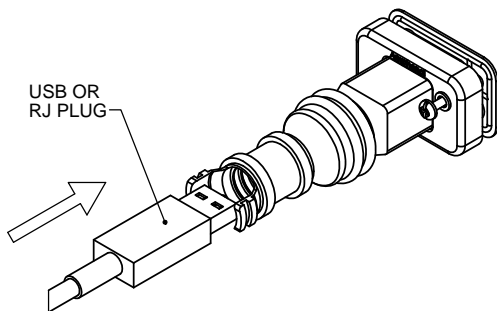

STEP 3
INSERT PLUG PARTIALLY
INTO THE BOOT.

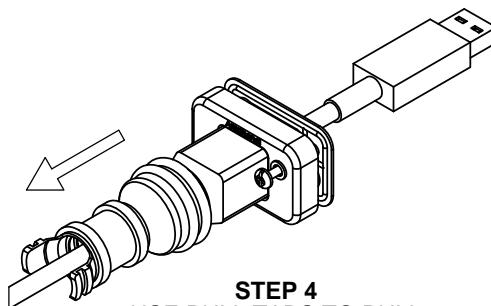

STEP 4
USE PULL TABS TO PULL
BOOT OVER PLUG.

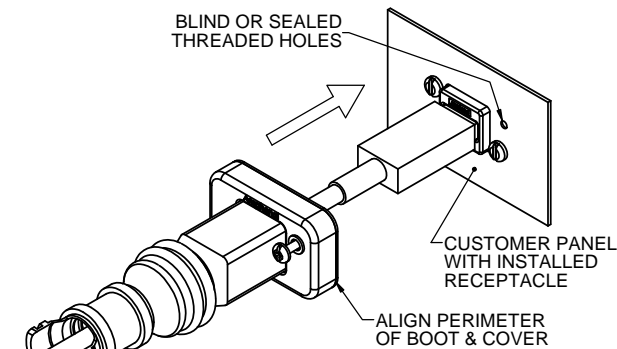

STEP 5
MATE PLUG INTO
RECEPTACLE.

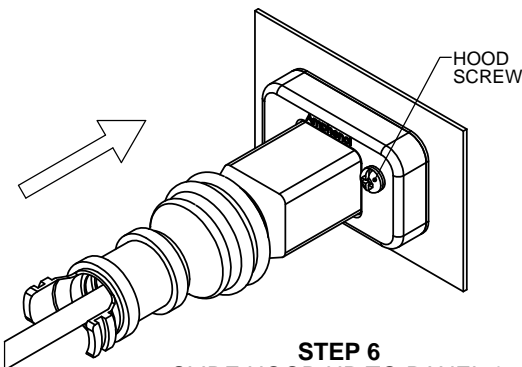

STEP 6
SLIDE HOOD UP TO PANEL &
SECURE HOOD SCREWS

REVISIONS			
REV	DESCRIPTION, ECN, EAR NO.	DATE	APP'D
D	PRODUCT DRAWING (EAR 14357)	MAR30/16	K.L.
E	PRODUCT DRAWING (EAR 14357)	JUN6/16	K.L.

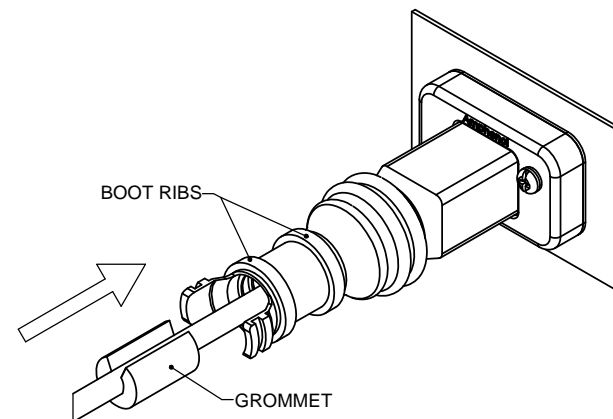

STEP 7
OPEN GROMMET ALONG SPLIT LINE,
PLACE OVER PLUG CABLE & SLIDE
INTO POSITION BETWEEN BOOT RIBS

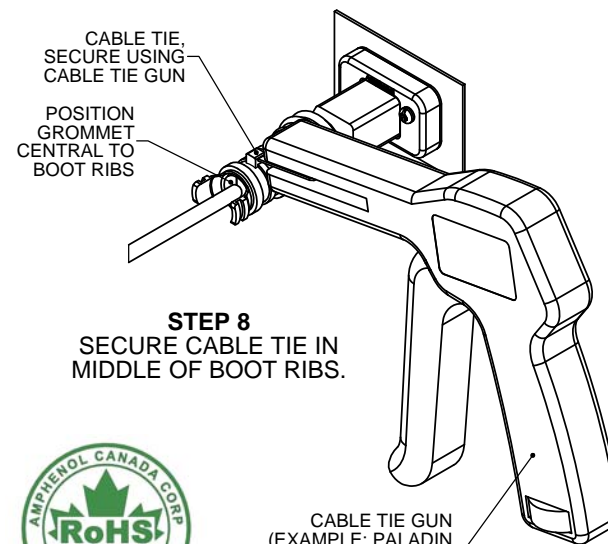

STEP 8
SECURE CABLE TIE IN
MIDDLE OF BOOT RIBS.



FIELD ASSEMBLY PROCEDURE

THIS DOCUMENT CONTAINS PROPRIETARY INFORMATION AND SUCH INFORMATION MAY NOT BE DISCLOSED TO OTHERS FOR ANY PURPOSE OR USED FOR MANUFACTURING PURPOSES WITHOUT WRITTEN PERMISSION FROM AMPHENOL CANADA CORP.

UNLESS SPECIFIED OTHERWISE	DRAWN	B.COPPING	DEC5/14
PRIMARY UNITS MILLIMETERS	CHECKED	K.LAMBIE	DEC5/14
SECONDARY UNITS INCHES	M.E. APP'D		
REFERENCE IN PARENTHESES	Q.A. APP'D		
GENERAL TOLERANCES	DWG APPR.		
1 DECIMAL PLACE	ENG. REL. NO.	EAR 14327	
2 DECIMAL PLACES	REF.		
3 DECIMAL PLACES	THIRD ANGLE PROJECTION		
ANGULAR DEGREES	DO NOT SCALE DRAWING		

Amphenol Canada Corp.
www.amphenolcanada.com

MUSBR HOOD FOR USB OR RJ PLUG,
BOOT STYLE DESIGN, FOR SEALING
MATING INTERFACE, RoHS COMPLIANT

DWG. NO.	P-MUSBR-AHD2-XX1XX	REV	E
CODE ID NO.	03554	DWG SIZE:	X
SCALE:	2:1	SHEET	3 OF 3

X-ON Electronics

Largest Supplier of Electrical and Electronic Components

Click to view similar products for [USB Connectors](#) category:

Click to view products by [Amphenol](#) manufacturer:

Other Similar products are found below :

[65-647-8-BK-BU](#) [950](#) [E8144-B01021-L](#) [A-USB A-LP-SMT-C](#) [A-USB B-TOP-C](#) [MUSBA511N5](#) [MUSBD11135](#) [217450-1](#) [CA 6 W LD](#)
[KMBVX-TH-5S-B30](#) [896-30-004-00-000000](#) [KUSBVX-BS1N-W30](#) [KUSBX-AP-KIT-SCBLK](#) [KUSBX-AS2N-W](#) [KUSBX-SMT2AP1S-W](#)
[KUSBX-SMT2AP1S-W30](#) [935](#) [957](#) [30-498-6](#) [17-210051](#) [1734082-1](#) [30-1574](#) [30-470](#) [30-489](#) [30-541](#) [30-572-3](#) [MAB 8 SN V](#) [A-USB A-](#)
[2P-C](#) [MIKROE-1451](#) [USBFTV2PEM2G](#) [USBFTVC6ZN](#) [KUSBX-AS2N-W30](#) [KUSBX-SLAS1N-W](#) [KUSBX-SMT-AS1N-W30](#) [4689-1](#) [1-](#)
[1734084-2](#) [E8110-001-01](#) [MUSBA81130](#) [33UBARS1-04SW11](#) [33UBAR-04SW11](#) [USBF21ZNSCC](#) [USBBFTV6ZC](#) [10135326-001LF](#)
[M9177/3-1](#) [925](#) [4198](#) [690-024-633-031](#) [KUSBEX-BSFS1N-W](#) [USBFTVC6MRG](#) [UA-20BMFA-SL8001](#)