



FEATURES

- Conceived and designed for easy customisation.
- SMD or Through-hole Mount.
- Endless Rotation (360°).
- Wide Electrical Angle (340° ± 10°).
- Extended Mechanical Life (100k cycles).
- Working Temperature Range (-40°C to +120°C).
- Low Profile (4.4 mm).
- Linearity: ± 3% (default).
- Embossed Tape or Bulk packaging.
- Reflow Soldering capability.
- Shaft insertable from both sides.
- Polarised "T" rotor (European Home Appliance standard).
- All PT/ PTC 15 shafts compatible.
- IP54 protection according to IEC 60529.

STANDARD SPECIFICATIONS

Resistance values*:	5k to 100k
Tolerance:	± 30%
Nominal Power:	0.15 W @ 50°C
Linearity (absolute):	± 3%
Taper:	Linear
Mechanical Life**:	100K cycles
Temperature Range:	-40°C to +120°C
Mechanical Angle:	360°
Electrical Angle:	340° ± 10°
Rotational Torque:	≤ 20 mN.m
Max. Voltage:	250 VDC

* Others: check availability

** 200K cycles version available check availability. For higher mechanical life see the Z15 product with 2M cycles.

TYPICAL APPLICATIONS

The N15 series offers an SMD and Through Hole mount solution for the majority of Position/Rotary Sensor and multi-purpose Control applications such as:

- Automotive HVAC, Seat, Rear-view mirror actuator feedback sensors and HVAC Controls
- Temperature Control for Boilers, Wall Heaters, Showers, Radiators, Conventional and Microwave Ovens, Freezers...
- Timer & Function/Programme Select for Washing Machines, Dishwashers and all White Goods in general.
- Size and Position detectors

HOW TO ORDER

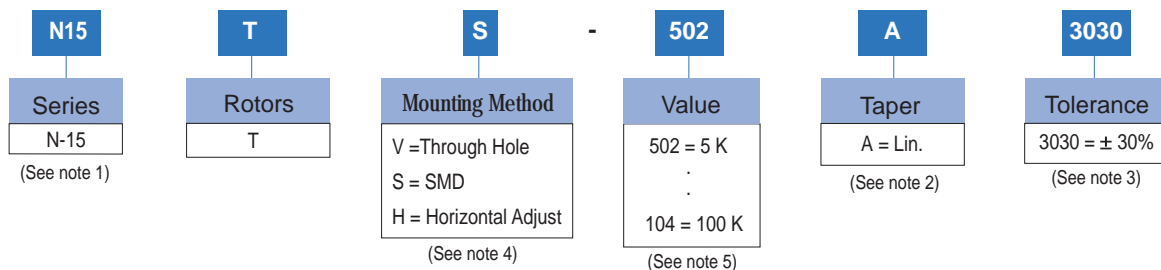

NOTES:

- (1) A wide variety of custom substrates available
- (2) Availability of a wide range of customised tapers and step curves
- (3) Others: check availability. Optional precision laser-trimmed voltage divider calibration
- (4) Horizontal adjust versions will be studied case by case
- (5) Value Example: Code: 50 $\overline{2}$ 5K Ω
 ↳ Numb of zeros
 ↳ First two digits of the value.

Shafts are not available mounted to the potentiometer and should be ordered separately

NOTE: The information contained here should be used for reference purposes only.

Wiper positioned at 50 % of the electrical angle.

N-15 T S + DRAWING NUMBER (Max. 16 digits)

This way of ordering should be used for options which are not included in the "How to order" standard and optional extras.

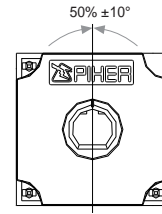

SMD MOUNT

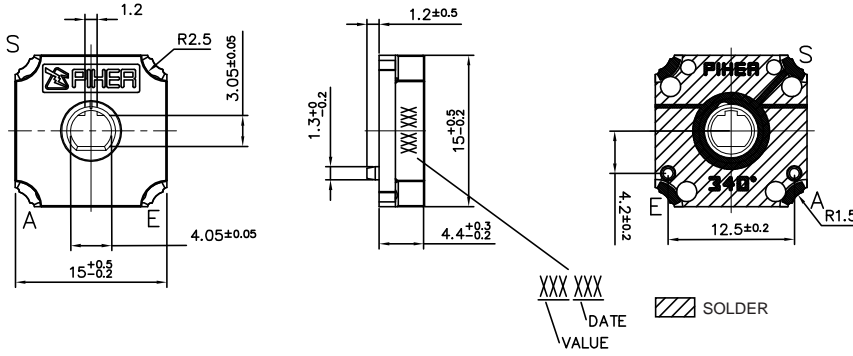

FOOT - PRINT

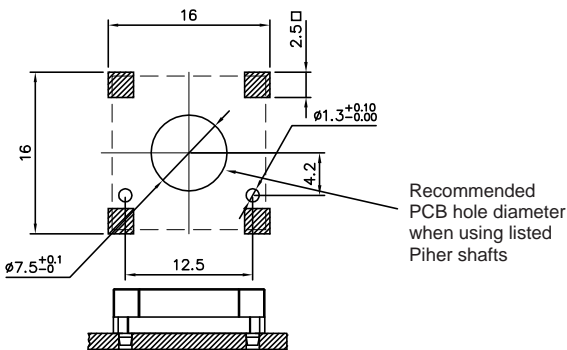

Download the STEP file here: <https://piher.net/piher/?p=924>

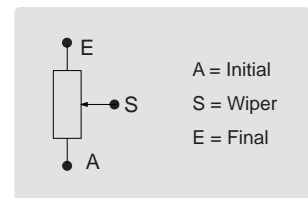

THROUGH HOLE MOUNT

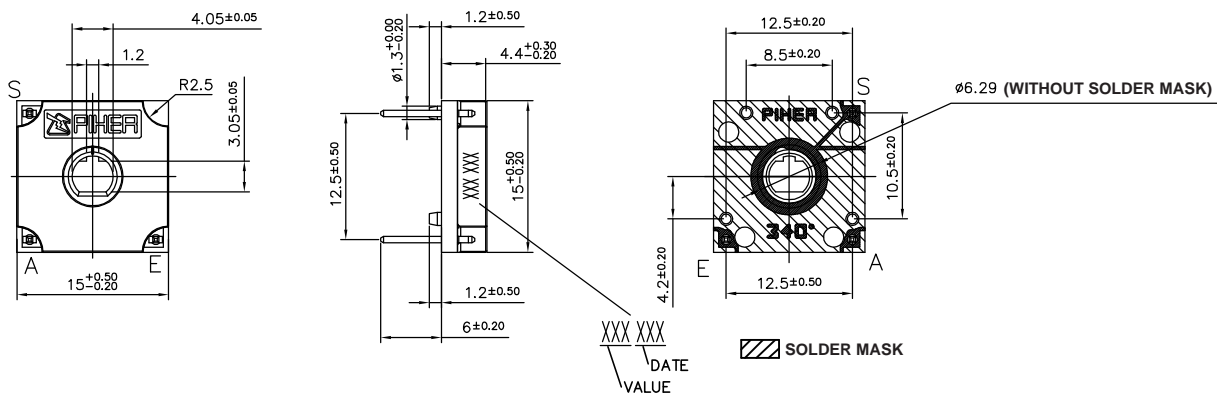

PCB HOLE LAYOUT 1

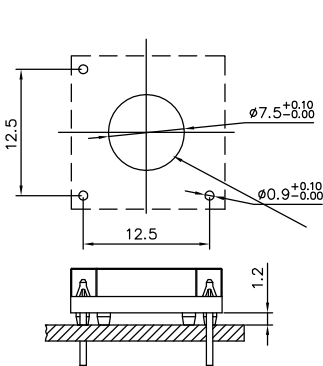

PCB HOLE LAYOUT 2

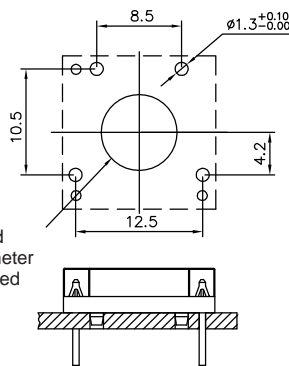

Recommended PCB hole diameter when using listed Piher shafts

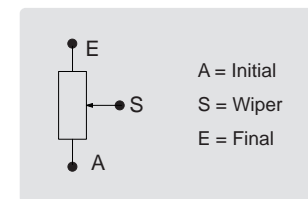

HORIZONTAL ADJUST - VERTICAL MOUNT

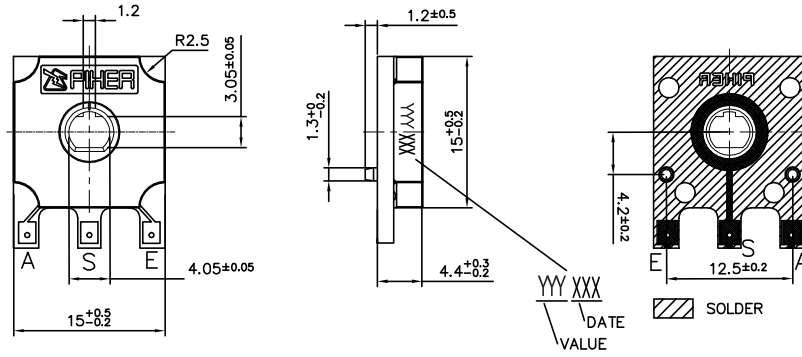

TESTS

TYPICAL VARIATIONS

ELECTRICAL LIFE	1.000 h. @ 50°C; 0.15 W	± 40 %
MECHANICAL LIFE (CYCLES)	100,000 @ 20 CPM	± 40 % (Rn < 100 K)
TEMPERATURE COEFFICIENT	-40°C to +120°C	±300 ppm (Rn < 100 K)
THERMAL CYCLING	10h. @ 120°C; 10h. @ -40°C	± 40 %
DAMP HEAT	500 h. @ 40°C @ 95% HR	± 40 %

NOTE : Out of range values may not comply these results.

PACKAGING

BULK

150 Units per box.
This is the default packaging for through-hole models.

If you want SMD models to be delivered with bulk packaging please contact Piher before ordering.

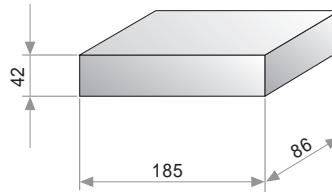

EMBOSSSED TAPE

500 Units per reel.
For SMD models only.

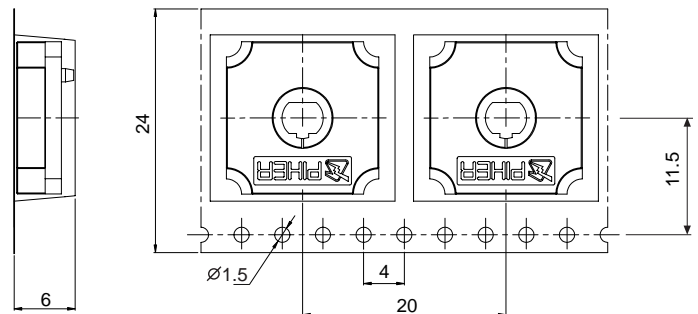
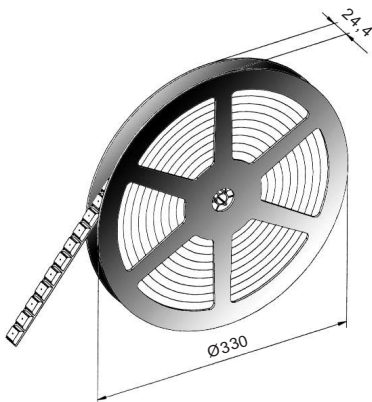

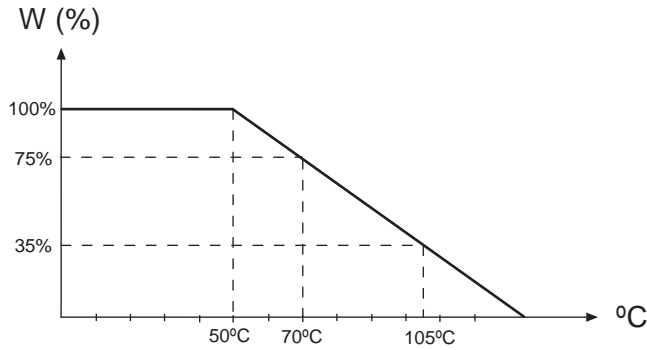

Recommended connection scheme for Piher's position sensors (voltage divider)

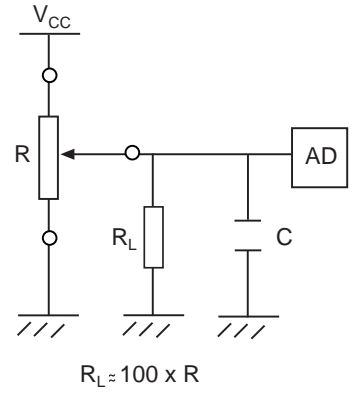

RECOMMENDED REFLOW PROFILE

SMD Types

SnPb Reflow Profile

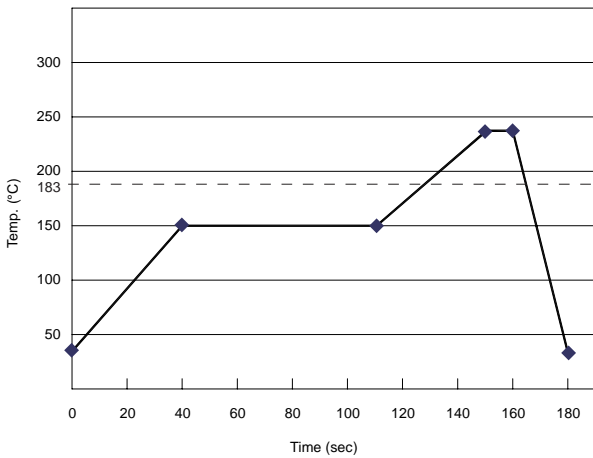

Lead Free Reflow Profile

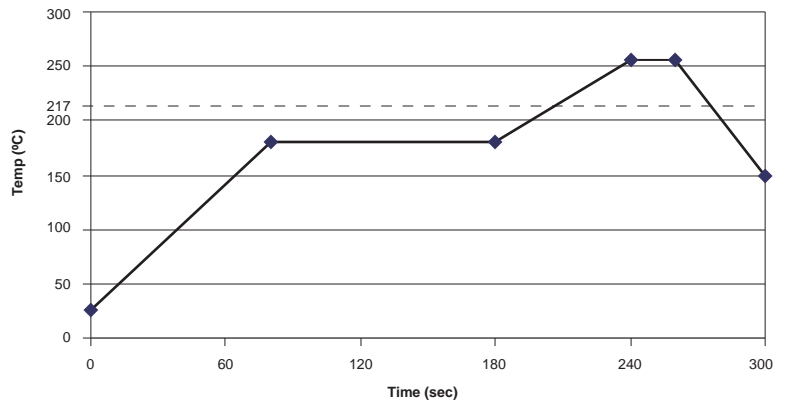

The recommended reflow profile is provided as a guideline. Optimal profile may differ due to oven type, assembly layout or other design or process variables. Customers should verify actual device performance in their specific application and reflow process. Please contact Piher if you require additional support.

SHAFTS

Hollow model shafts

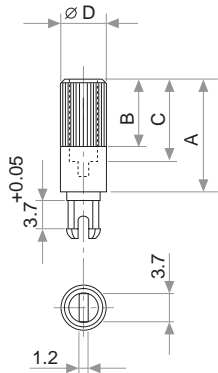

FIG.	A	B	C	D	Ref.
1	12	9	8	6	5272
2	19	9	15	6	5214
5	9.5	6.5	5.5	6	5208
9	35	9	15	6	5216
10	37.8	9	33.8	6	5218
11	35	25	31	6	5209
13	7.8	4.8	3.8	6	5265

Solid model shafts

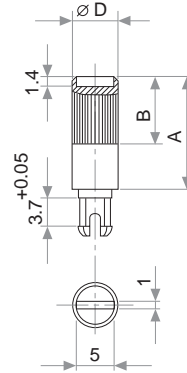

FIG.	A	B	D	Ref.
6	15	9	6	5219
7	16.8	9	6	5220
8	25.3	9	6	5207
12	46	5	6	5227

Slot (1 x 1.4) perpendicular to wiper position. Fig. 12 slot is on line with wiper position.

A = Length (FRS); B=Knurling length; C=Hollow depth; D=Shaft diameter; FRS=From rotor surface

Other shafts

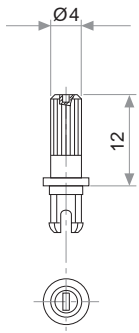

Fig. 3 / Ref. 5372

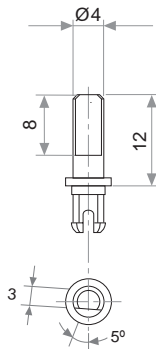

Fig. 15 / Ref. 5217

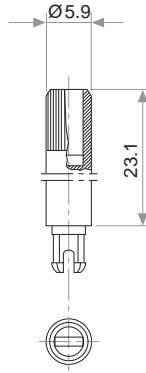

Fig. 17 / Ref. 5210

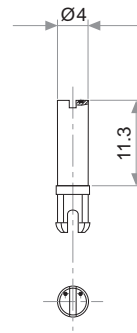

Fig. 18 / Ref. 5271

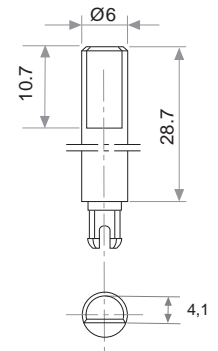

Fig. 19 / Ref. 6032*

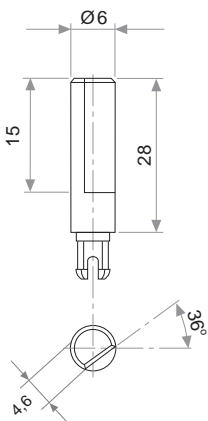

Fig. 20 / Ref. 5369*

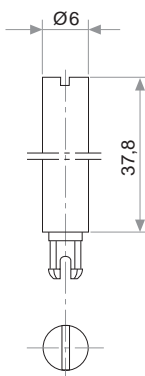

Fig. 21 / Ref. 6031*

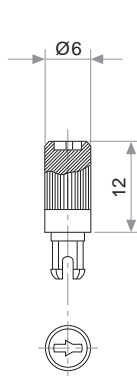

Fig. 22 / Ref. 6029

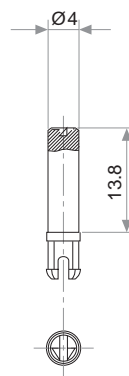

Fig. 23 / Ref. 6022

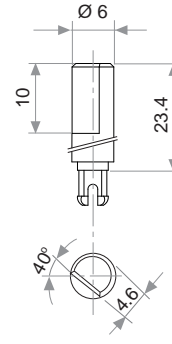

Fig. 29 / Ref. 6162

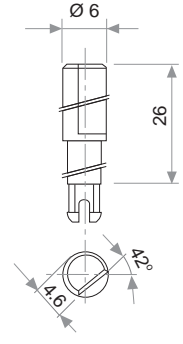

Fig. 25 / Ref. 6059

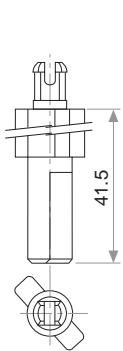

Fig. 27 / Ref. 5268*

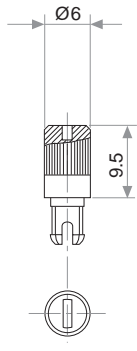

Fig. 28 / Ref. 6055

* Not available in self extinguishable plastic

Disclaimer

The product information in this catalogue is for reference purposes. Please consult for the most up to date and accurate design information. Piher Sensors & Controls S.A., its affiliates, agents, and employees, and all persons acting on its or their behalf (collectively, "Piher"), disclaim any and all liability for any errors, inaccuracies or incompleteness contained herein or in any other disclosure relating to any product described herein.

Piher disclaims any and all liability arising out of the use or application of any product described herein or of any information provided herein to the maximum extent permitted by law. The product specifications do not expand or otherwise modify Piher's terms and conditions of sale, including but not limited to the warranty expressed therein, which apply to these products.

No licence, express or implied, by estoppel or otherwise, to any intellectual property rights is granted by this document or by any conduct of Piher.

The products shown herein are not designed for use in medical, life-saving, or life-sustaining applications unless otherwise expressly indicated.

Customers using or selling Piher products not expressly indicated for use in such applications do so entirely at their own risk and agree to fully indemnify Piher for any damages arising or resulting from such use or sale. Please contact authorised Piher personnel to obtain written terms and conditions regarding products designed for such applications.

Product names and markings noted herein may be trademarks of their respective owners.

Piher is an Amphenol™ company.

All Piher products can be adapted to meet customer's requirements. Please always use the latest updated datasheets published on our website www.piher.net.

Information contained in and/or attached to this catalogue may be subject to export control regulations of the European Community, USA, or other countries. Each recipient of this document is responsible to ensure that usage and/or transfer of any information contained in this document complies with all relevant export control regulations. If you are in any doubt about the export control restrictions that apply to this information, please contact the sender immediately. For any Piher Sensors & Controls Exports, Note: All products / technologies are EAR99 Classified commodities. Exports from the United States are in accordance with the Export Administration Regulations. Diversion contrary to US law is prohibited.



X-ON Electronics

Largest Supplier of Electrical and Electronic Components

Click to view similar products for [Trimmer Resistors - Through Hole](#) category:

Click to view products by [Amphenol](#) manufacturer:

Other Similar products are found below :

[64W205](#) [M63M103KB40](#) [M63X104KB40](#) [76PR500K](#) [79PR5K](#) [PT15NV24-103A2020](#) [CT6P-103](#) [CB10MV473ME](#) [4270W105K](#)
[56PR2MEG](#) [82PR2KLFTB](#) [62MR100](#) [72XWR20K](#) [9702-2SL-1](#) [89PHR10K](#) [78SR5K](#) [CT15NV15103M](#) [78SBWR1K](#) [343P10](#)
[82PR100LFTB](#) [PT15NH02-104A2020-S](#) [VG039NSNXTB103](#) [PTC15NH05-103A2020](#) [PTC15NV02-104A2020](#) [PTC15LV02-103A2020](#)
[PT15GV02-27402](#) [RJ-13SR203](#) [RJ-5EW502](#) [RJ-5EW202](#) [3292W-1-201M](#) [3362F-1-205LF](#) [3362X-1-272LF](#) [3386H-EY5-202LF](#) [3059Y-1-](#)
[200LF](#) [3386X-DF6-503LF](#) [3260W-1-500](#) [3329S-1-204LF](#) [PV36W103C01B00](#) [CN-15.1-22K](#) [CN-15.1-3K3](#) [CN-15.2-10K](#) [CN-15.2-470R](#)
[R0141-2-100K](#) [R0141-2-10K](#) [R0141-2-1K](#) [R0141-2-20K](#) [R0141-2-5K](#) [1028F-500K](#) [R16148-1A-1-A22K](#) [R16148-1A-1-A2K2](#)