

| REVISIONS |     |                |             |       |       |
|-----------|-----|----------------|-------------|-------|-------|
| REV       | ECO | DESCRIPTION    | DATE        | BY    | APPR  |
| A1        | --  | FIRST RELEASED | APR-10-2020 | BLINK | TOMMY |

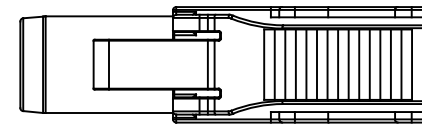
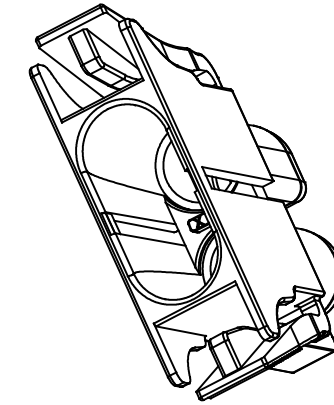
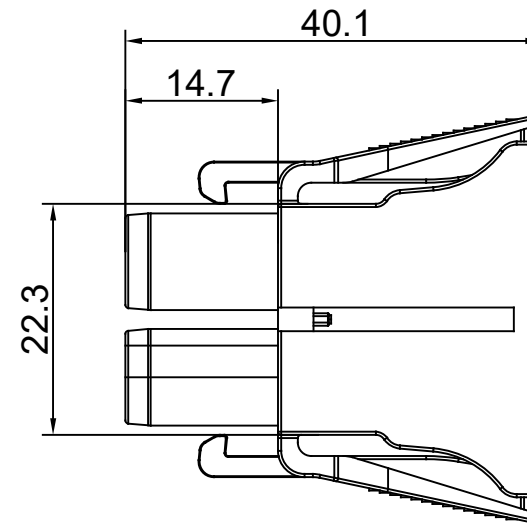
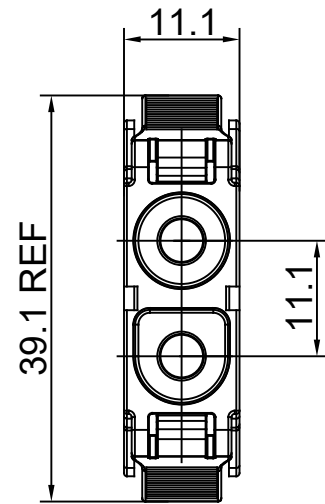

NOTES: (UNLESS OTHERWISE SPECIFIED)

1. MATERIAL:

SHELL: THERMOPLASTIC, UL94 V-0.

2. SPECIFICATIONS:

2.1, OPERATING TEMPERATURE: -40~125°C.

2.2, MATING CYCLES DURABILITY: 100 CYCLES MIN (MATING WITH PL000727).

2.3, RoHS COMPLIANT.

3. ALL DIMENSIONS ARE FOR REFERENCE USE ONLY.

TITLE: TELECOM 4mm CONNECTOR PLUG HOUSING  
 DWG NO.: PL000728  
 REV: A1  
 SH: 1  
 OF: 1

| QUANTITY                                                                                                                                                                                                          | PART NUMBER | DESCRIPTION                                                                                                                                                                                                                                                                                                                                                                | ITEM     |                                                                |      |              |             |                |             |           |    |                 |             |           |      |              |  |
|-------------------------------------------------------------------------------------------------------------------------------------------------------------------------------------------------------------------|-------------|----------------------------------------------------------------------------------------------------------------------------------------------------------------------------------------------------------------------------------------------------------------------------------------------------------------------------------------------------------------------------|----------|----------------------------------------------------------------|------|--------------|-------------|----------------|-------------|-----------|----|-----------------|-------------|-----------|------|--------------|--|
| <b>MATERIALS LIST</b>                                                                                                                                                                                             |             |                                                                                                                                                                                                                                                                                                                                                                            |          |                                                                |      |              |             |                |             |           |    |                 |             |           |      |              |  |
| UNLESS OTHERWISE SPECIFIED<br>1) All dimensions are in metric(mm).<br>2) Tolerances are as follows:<br>1 PL DEC ±0.30<br>2 PL DEC ±0.15<br>3 PL DEC ±0.08<br>Fractions ±1/64<br>Angles ±1°<br>3) Note reference = |             | <table border="1"> <thead> <tr> <th>SIGNATURES</th> <th>DATE</th> </tr> </thead> <tbody> <tr> <td>DRAWN: BLINK</td> <td>APR-10-2020</td> </tr> <tr> <td>CHECKED: ORION</td> <td>APR-13-2020</td> </tr> <tr> <td>ENGINEER:</td> <td></td> </tr> <tr> <td>APPROVAL: TOMMY</td> <td>APR-15-2020</td> </tr> <tr> <td>CUSTOMER:</td> <td></td> </tr> </tbody> </table>          |          | SIGNATURES                                                     | DATE | DRAWN: BLINK | APR-10-2020 | CHECKED: ORION | APR-13-2020 | ENGINEER: |    | APPROVAL: TOMMY | APR-15-2020 | CUSTOMER: |      |              |  |
| SIGNATURES                                                                                                                                                                                                        | DATE        |                                                                                                                                                                                                                                                                                                                                                                            |          |                                                                |      |              |             |                |             |           |    |                 |             |           |      |              |  |
| DRAWN: BLINK                                                                                                                                                                                                      | APR-10-2020 |                                                                                                                                                                                                                                                                                                                                                                            |          |                                                                |      |              |             |                |             |           |    |                 |             |           |      |              |  |
| CHECKED: ORION                                                                                                                                                                                                    | APR-13-2020 |                                                                                                                                                                                                                                                                                                                                                                            |          |                                                                |      |              |             |                |             |           |    |                 |             |           |      |              |  |
| ENGINEER:                                                                                                                                                                                                         |             |                                                                                                                                                                                                                                                                                                                                                                            |          |                                                                |      |              |             |                |             |           |    |                 |             |           |      |              |  |
| APPROVAL: TOMMY                                                                                                                                                                                                   | APR-15-2020 |                                                                                                                                                                                                                                                                                                                                                                            |          |                                                                |      |              |             |                |             |           |    |                 |             |           |      |              |  |
| CUSTOMER:                                                                                                                                                                                                         |             |                                                                                                                                                                                                                                                                                                                                                                            |          |                                                                |      |              |             |                |             |           |    |                 |             |           |      |              |  |
| MATERIAL SPECIFICATIONS:                                                                                                                                                                                          |             | <div style="text-align: center;"> <h1>Amphenol</h1> <p>Sine Systems - <a href="http://www.amphenol-sine.com">www.amphenol-sine.com</a><br/>           44724 Morley Drive<br/>           Clinton Township, MI 48036</p> </div>                                                                                                                                              |          |                                                                |      |              |             |                |             |           |    |                 |             |           |      |              |  |
| PROCESS SPECIFICATIONS:                                                                                                                                                                                           |             |                                                                                                                                                                                                                                                                                                                                                                            |          |                                                                |      |              |             |                |             |           |    |                 |             |           |      |              |  |
| NEXT ASSY:                                                                                                                                                                                                        |             | <table border="1"> <tr> <td colspan="2" style="text-align: center;">4MM, FEMALE PLUG HOUSING<br/>FOR USE WITH PL000729, PRM SERIES™</td> </tr> <tr> <td>SIZE</td> <td>TYPE</td> <td>DWG NO.</td> <td>REVISION</td> </tr> <tr> <td>B</td> <td>C-</td> <td>PL000728</td> <td>A1</td> </tr> <tr> <td>SCALE:</td> <td>NONE</td> <td>SHEET 1 OF 1</td> <td></td> </tr> </table> |          | 4MM, FEMALE PLUG HOUSING<br>FOR USE WITH PL000729, PRM SERIES™ |      | SIZE         | TYPE        | DWG NO.        | REVISION    | B         | C- | PL000728        | A1          | SCALE:    | NONE | SHEET 1 OF 1 |  |
| 4MM, FEMALE PLUG HOUSING<br>FOR USE WITH PL000729, PRM SERIES™                                                                                                                                                    |             |                                                                                                                                                                                                                                                                                                                                                                            |          |                                                                |      |              |             |                |             |           |    |                 |             |           |      |              |  |
| SIZE                                                                                                                                                                                                              | TYPE        | DWG NO.                                                                                                                                                                                                                                                                                                                                                                    | REVISION |                                                                |      |              |             |                |             |           |    |                 |             |           |      |              |  |
| B                                                                                                                                                                                                                 | C-          | PL000728                                                                                                                                                                                                                                                                                                                                                                   | A1       |                                                                |      |              |             |                |             |           |    |                 |             |           |      |              |  |
| SCALE:                                                                                                                                                                                                            | NONE        | SHEET 1 OF 1                                                                                                                                                                                                                                                                                                                                                               |          |                                                                |      |              |             |                |             |           |    |                 |             |           |      |              |  |

## **X-ON Electronics**

Largest Supplier of Electrical and Electronic Components

*Click to view similar products for [Headers & Wire Housings](#) category:*

*Click to view products by [Amphenol](#) manufacturer:*

Other Similar products are found below :

[Amphenol](#)